



**GLOW 10L**  
THERMOELECTRIC  
**COOLER &**  
**WARMER**

Instruction Manual

*Cooluli*<sup>®</sup>  
~~~~~

# TABLE OF CONTENTS

**Page 2**

**Product Specs & Features**

**Page 3**

**Warranty Information**

**Page 4**

**Characteristics, Applications, & What's in the Box**

**Page 5**

**Getting Started**

**Page 6**

**Optimizing Performance**

**Page 7-8**

**Frequently Asked Questions**

**Page 9**

**Basic Troubleshooting**

**Page 10**

**Customer Support**

**Page 11**

**Product Warnings**





## I10L2WM-E COOLER & WARMER

### GLOW-10L FEATURES

**Cools down to:**  
30°F (16°C)  
below ambient temperature

**Warms up to:**  
120°F (49°C) by  
internal thermostat

**Materials:**  
Aluminum, Plastic &  
Tempered Glass

**Inner Dimensions:**  
(W x D x H)  
7 x 6.5 x 10.9 in.  
178 x 165 x 277 mm

**Outer Dimensions:**  
(W x D x H)  
9.4 x 11.4 x 13.4 in.  
239 x 290 x 340 mm

**Input/Energy Consumption:**  
AC 100–240V  
DC 12V/3A  
36w max

**Weight:**  
7.9 lbs/3.58 kg

# WARRANTY INFORMATION

## 1-YEAR LIMITED WARRANTY - REGISTER AT: [www.cooluli.com/register](http://www.cooluli.com/register)

Read all the instructions before attempting to use this product.

This 1-year limited warranty applies to repair or replacement if product, at COOLULI's option, is found to be defective in material or workmanship.

1. This warranty only applies to personal, non-commercial use. This warranty is not applicable to any damage resulting from commercial, abusive, unreasonable use or supplemental damage. Defects that are the result of normal wear and tear will not be considered manufacturing defects under this warranty.

**COOLULI IS NOT LIABLE FOR INCIDENTAL OR CONSEQUENTIAL DAMAGES OF ANY NATURE. ANY IMPLIED WARRANTY OF MERCHANTABILITY OR FITNESS FOR A PARTICULAR PURPOSE ON THIS PRODUCT IS LIMITED IN DURATION TO THE DURATION OF THIS WARRANTY.**

2. This warranty does not cover damage resulting from any unauthorized attempts to repair or from any use not in accordance with the Instruction Manual.

3. This warranty applies only to the original purchaser of this product from the original date of purchase. This warranty applies only if the unit is purchased new from an authorized retailer and is non-transferable from the original purchaser of the item. Any warranties accompanied with this product is only valid in the country of purchase.

4. This unit is manufactured according to worldwide voltage specifications. The use of certified plug adapters is acceptable, however, Cooluli assumes no liability for the quality or safety of third-party adapters.

5. Please read the Instruction Manual carefully before setting up or using this product. If you believe this product to be suffering from a manufacturing fault, or if you have inquiries about this product, please contact Customer Support:

COOLULI  
ATTN: Customer Support  
217 E. Highland Pkwy  
Roselle, NJ 07203  
Phone: (646) 787-1104  
Email: [info@cooluli.com](mailto:info@cooluli.com)

When contacting Customer Support, please have the information below along with the proof of purchase. All warranty requests must be accompanied by proof of purchase, which is a copy of the original receipt/invoice.

Model: \_\_\_\_\_

Date of purchase: \_\_\_\_\_

Purchased from: \_\_\_\_\_

# Product Characteristics

- This thermoelectric cooler and warmer is a great way to keep food and drinks cool during the summer and warm during the winter. Perfect to use at home, in your office, or in your car. Wherever you are, you can always enjoy fresh food and drinks.
- Easily portable and sleek, it makes a stylish choice for any décor or setting.
- Shelves and container baskets are removable. To remove shelves: gently push shelves up and slide out. To remove container basket: gently push up and lift basket from slots.
- The external power adapter makes it easy for indoor and outdoor use. This thermoelectric cooler/warmer unit is ultra-durable, eco-friendly and safe to use. Its semiconductor operation consumes minimal power and uses no compressors, cryogen, refrigerants, or Freons.

## Applications

- At home, keep snacks and drinks at hand while enjoying your favorite shows and movies uninterrupted.
- Store on top of your office desk and use it as your own personal mini fridge.
- Great for picnics, camping and fishing trips when cold drinks and warm food are a necessity.
- Ideal for long road trips, and for commuters, and truck and taxi drivers who want to keep food and drinks fresh and close by.
- Perfect for parents who need to store breast milk at a desired temperature.
- Safely store medications that need to be kept at a specific temperature.

## What's in the Box

GLOW 10L

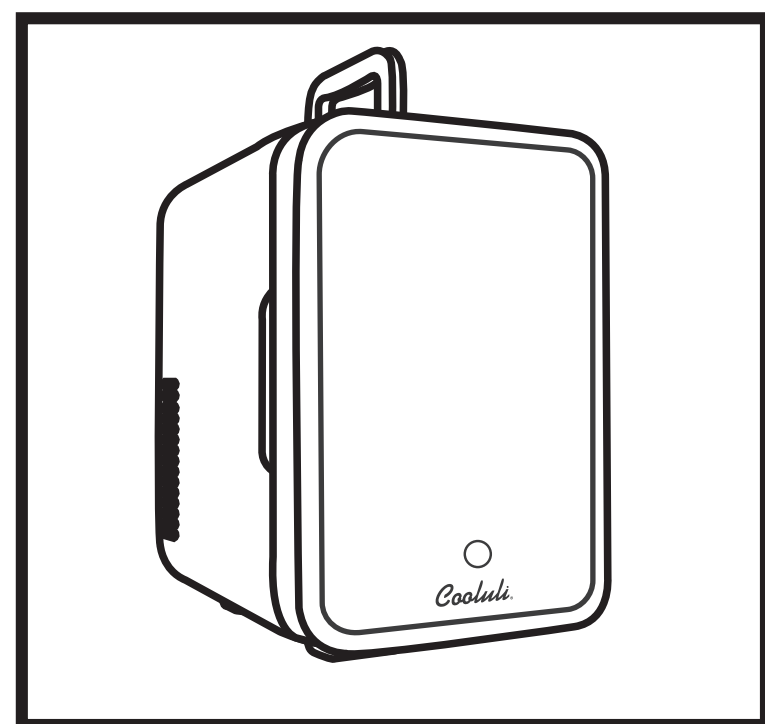

Fig. 1

EXTERNAL POWER ADAPTER

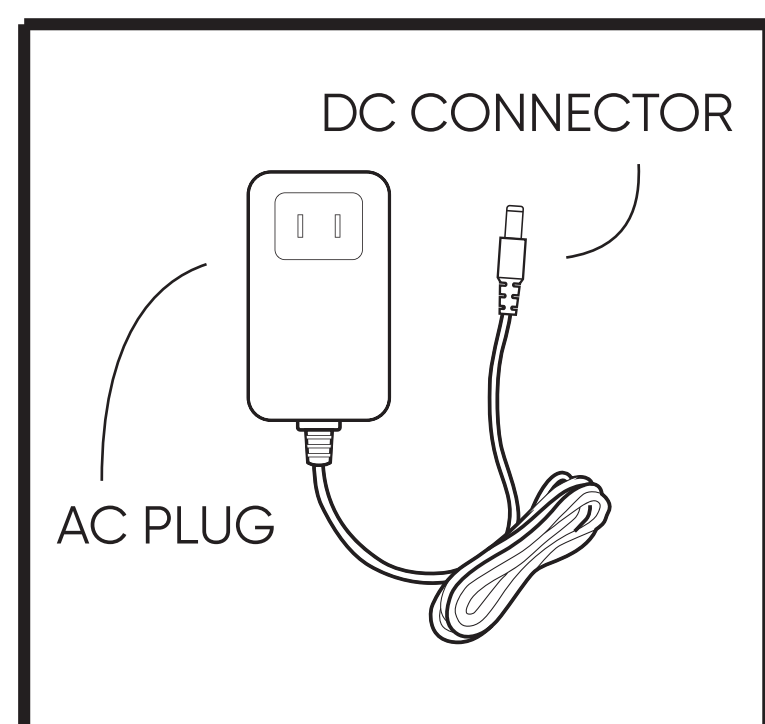

Fig. 2

CAR ADAPTER

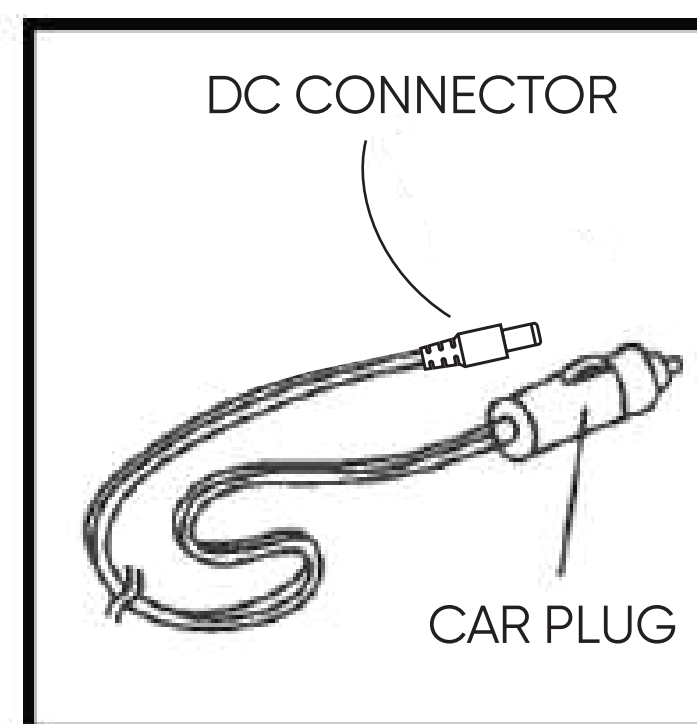

Fig. 3

INSTRUCTION MANUAL

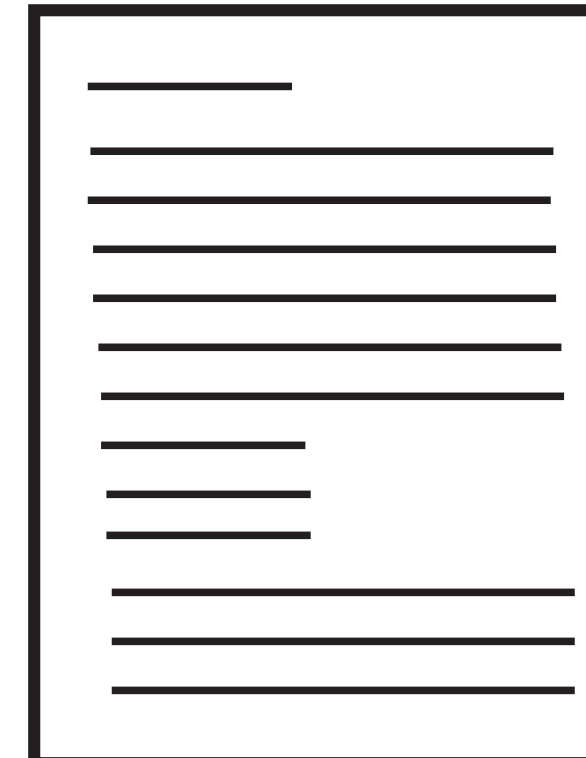

Fig. 4



# Getting Started

1. **Before plugging in the cooler/warmer unit:** make sure the switch on the back of the unit is set to the OFF setting.
2. **A minimum 2" vent clearance** is required for proper ventilation.
3. **Plugging in your unit:**

**For home applications:** Use the supplied external power adapter (see Fig.2) by inserting the DC connector into unit's DC port (see Fig. 5) and inserting the AC plug into a wall outlet.

This unit works on 100-240V (in compliance with worldwide standards).

**For motor vehicle application:** Car engine MUST be turned on first before plugging in the cooler/warmer. This precaution prevents a power surge that can lead to the unit overheating and/or becoming a potential fire risk. Use the supplied DC power cord (see Fig. 3) and insert DC connector into unit's DC port (see Fig. 5) and the DC plug into the appropriate cigarette-lighter outlet.

4. **Turning on your unit:**

**For Cooling:** Set the power switch to the COLD setting. A green light will turn on to indicate that the unit is in cooling mode.

**For Warming:** Set the power switch to the HOT setting. A red light will turn on to indicate that the unit is in warming mode.

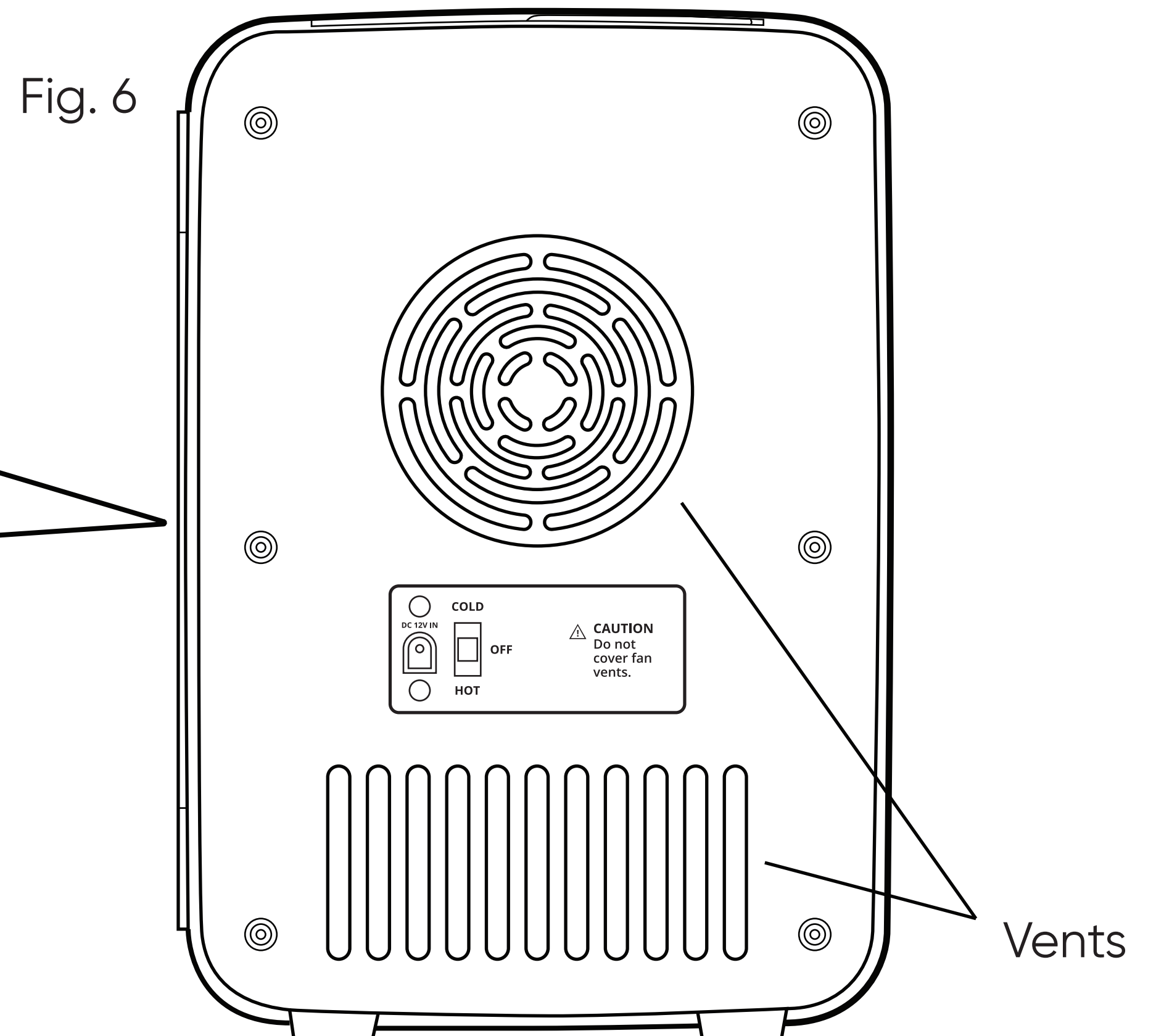
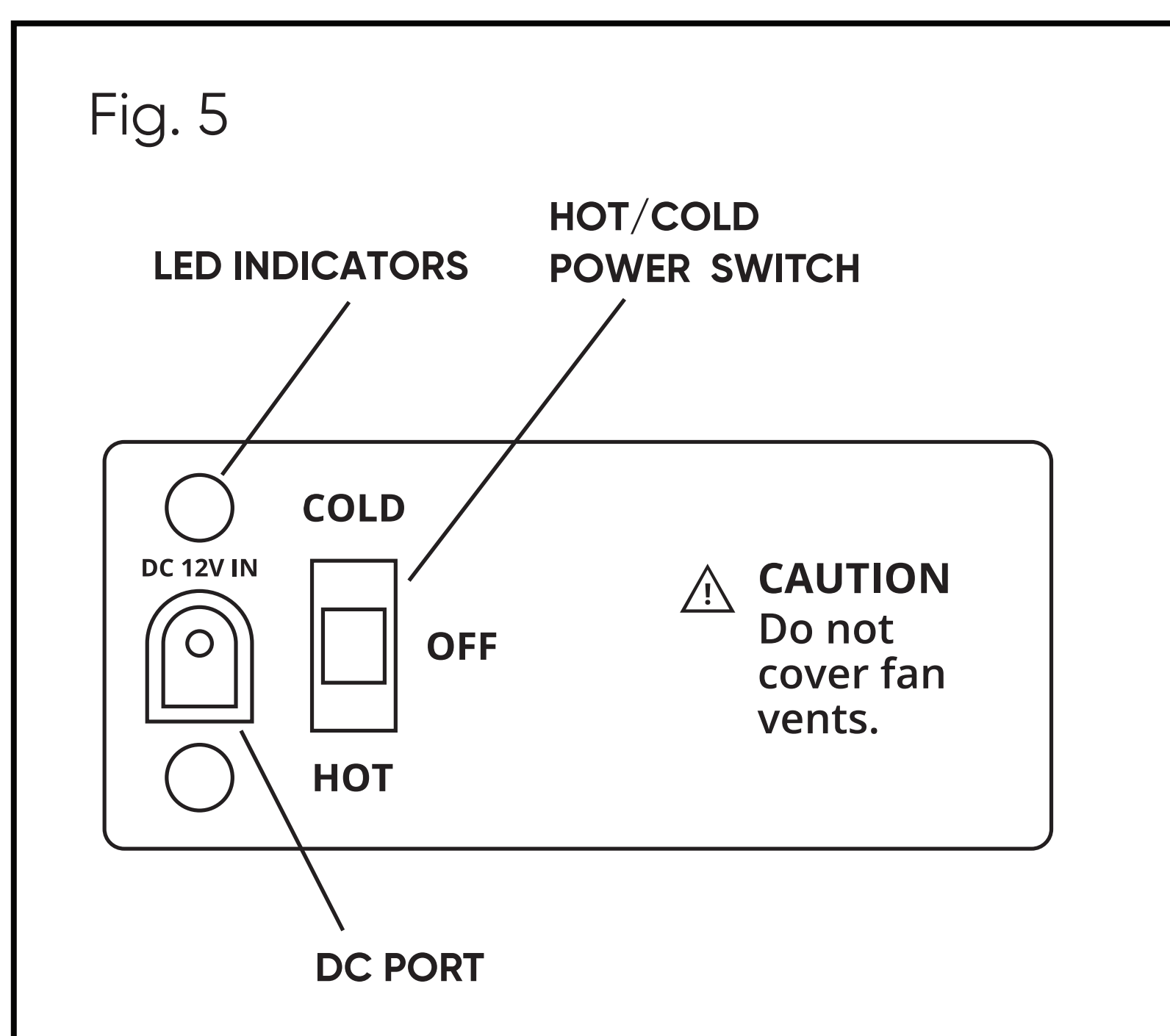

# Optimizing Performance

- **To control LED light ring:**

Press the circle icon above the Cooluli logo on the front of the door.

**LED modes toggle between HIGH, MEDIUM, LOW, and OFF.**

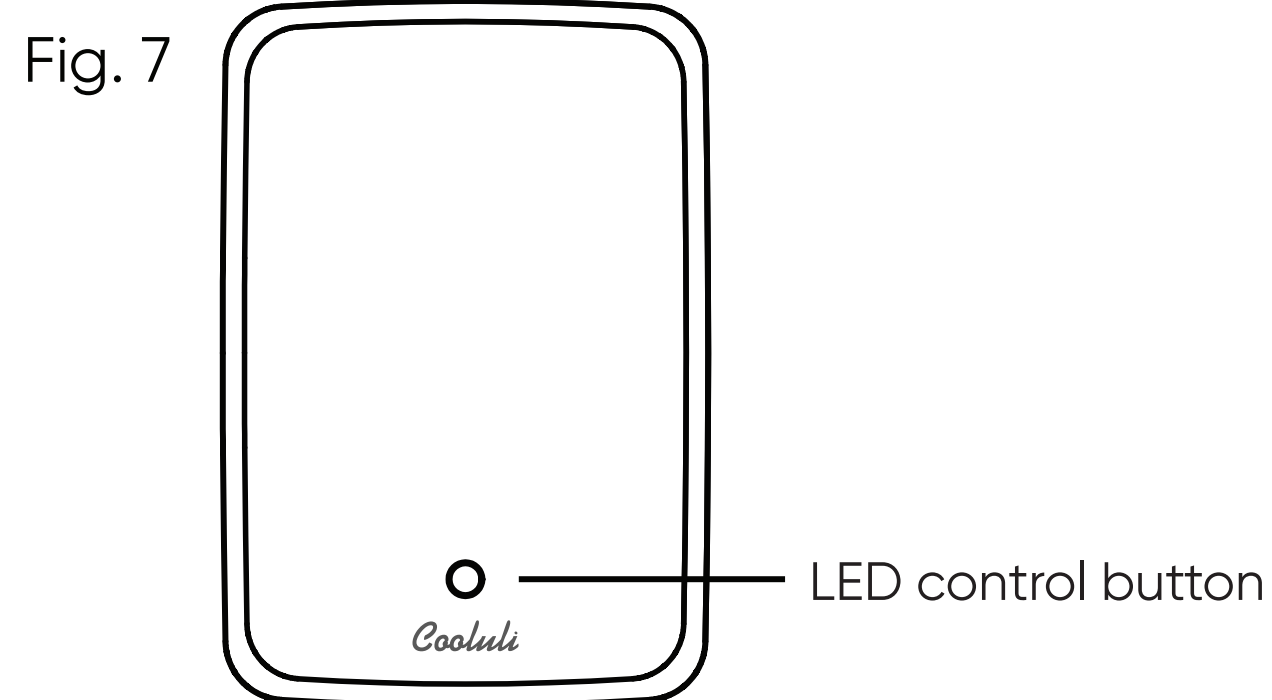

- Pre-chilled food and drinks are recommended to put into this unit. If drinks are at room temperature it will take 2-3 hours to chill them.
- This thermoelectric cooler and warmer is not designed to heat cold food; this unit only preserves hot foods at a warm temperature. However, this unit does have the ability to heat some foods that are semi-cool if given a minimum of 2 hours.
- Exclusive EcoMax Technology features our unique semiconductor operation that prevents frost, and is energy efficient and cost-effective—when maximum efficiency is reached, the Glow goes into ECOmode to save you money.
- With proper use, this thermoelectric cooler and warmer unit can preserve the temperature of food, warm or cold, all day.
- NOTE: Ambient temperature refers to the temperature of the surrounding air. For example, if unit is used for cooling, and your immediate surroundings is 75°F, then the unit will keep contents cool at around 45°F.

**The Glow -10L can fit 12 standard soda cans (12 fl. oz./355 ml) in the following configuration:**

- Remove basket shelf from interior door
- There are two shelves in the main unit; remove lower interior shelf by gently pushing the shelf up and sliding it out
- Refer to Fig.8 and Fig.9 below for suggested can configuration

Fig. 8

Can placement: overhead interior view of top shelf

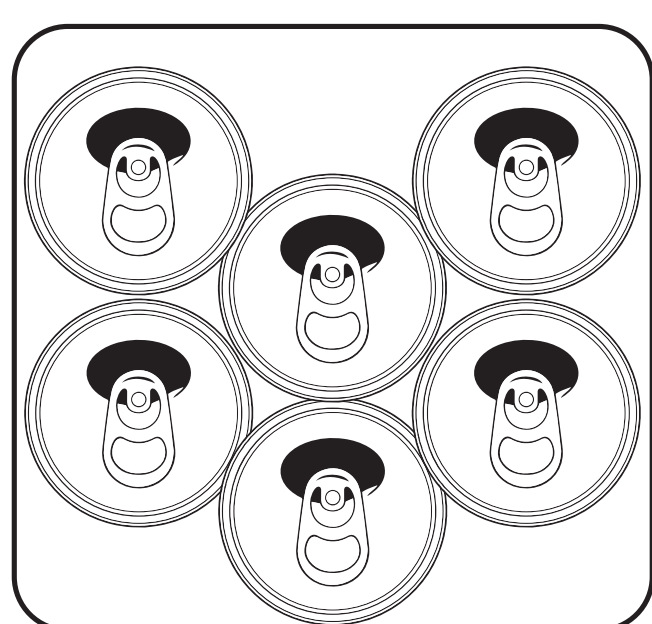
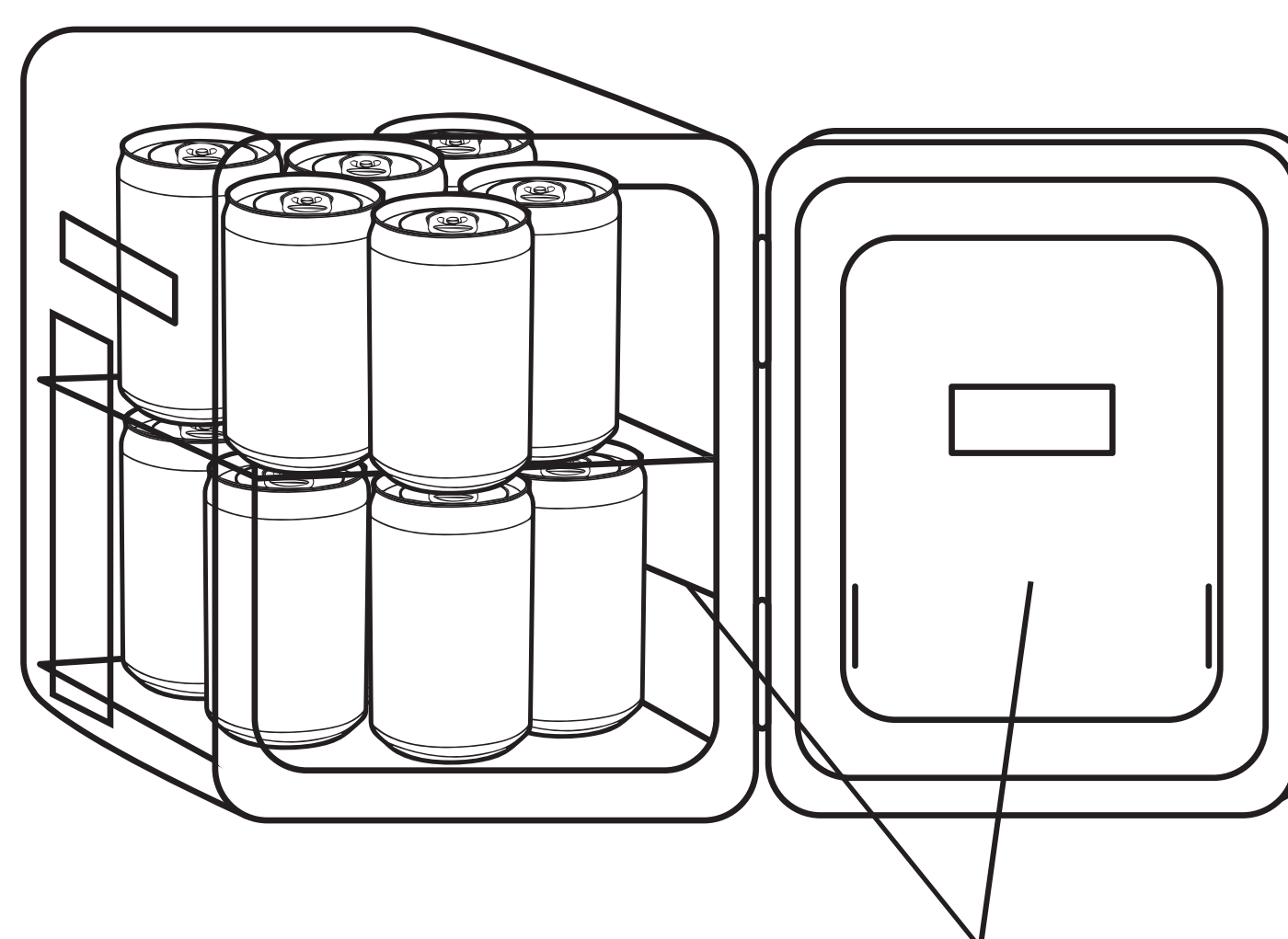

Fig. 9

Can placement: interior, top and bottom shelf view



Shelf & basket removed



# Frequently Asked Questions

## **Can I keep breast milk in my Cooluli unit?**

Yes! Many new parents use our units to store breast milk conveniently in nurseries or nearby bedrooms.

## **Can I store insulin in my Cooluli unit?**

Yes, many of our customers use our units to store medications and other essentials.

## **Can my Glow -10L keep things frozen?**

The Glow-10L should not be used as a freezer. Your Glow-10L has the ability to keep things cool (or warm—depending which mode you choose). Frozen items will cool down to 30° below ambient temperature. Therefore, if you put a frozen item inside your unit and your room is 70° F, that item will be kept at a temperature close to 40°F.

## **What is the cooling temperature of the Glow -10L?**

The Glow-10L can keep contents (food, drinks, snacks, medications, etc.) cool around 30°F below ambient temperature. Please refer to page 2 of this Instruction Manual for complete product specifications.

## **Can I adjust the thermostat on the Glow-10L?**

No, the Glow-10L does not have a thermostat. ONLY units with a digital display (the Concord series and Venture series) have a thermostat that can be set.

## **Does the Glow -10L have a lock?**

Yes, your Glow-10L has a secure, spring-lock door handle that is easy to open and close.

## **Are interior shelves removable?**

The shelves and container basket on the Glow-10L unit are removable. To remove, gently push the shelves up and slide out. To remove container basket: gently push up and lift basket from slot.

## **The back of my Glow -10L feels warm. Is this normal?**

Yes, this is normal. While in cooling mode, your Glow-10L Thermoelectric Cooler/Warmer moves heat from inside the unit to the back of the unit (vent area). Make sure there is at least a 2-inch clearance for necessary air flow and circulation. If the back of your Infinity gets very hot, turn off the unit, and contact Customer Support.



## **I hear a slight whirring sound in the back of my Glow-10L. Is this OK?**

The fan makes a slight whirring sound in the Glow-10L; this sound is normal. The Glow-10L features exclusive EcoMax™ Technology—our unique cooling system that makes our thermoelectric units quiet, yet powerful and efficient. However, if you hear a very loud sound, turn off the unit, and contact Customer Support.

## **Can I leave my Glow-10L plugged in every day, 24 hours per day?**

Yes, you can leave your Cooluli unit plugged into an AC outlet in your home or office. For your car, see question below.

## **If I plug my cooler/warmer unit into my car does the car engine need to be on for the unit to stay on?**

For car or motor vehicle use, we recommend unplugging your cooler/warmer unit when the car engine is off. Do not have the unit plugged in unless the engine is running.

## **Can I use my Glow-10L in a 220V outlet?**

The Glow-10L works in 100-240V, in compliance with worldwide standards. While the use of certified plug adapters is acceptable, Cooluli assumes no liability for the quality or safety of third-party adapters.

## **Can I use a power bank (portable charger) with my Glow-10L?**

No, a power bank cannot be used with the Glow-10L.

## **How much energy does the Glow-10L consume?**

Refer to page 2 of the Instruction Manual for spec details and information.

## **Does my Glow-10L come with a warranty?**

Yes, Glow-10L model comes with a standard 1-year limited warranty. Please refer to page 3 of the Instruction Manual or go to [info@cooluli.com](mailto:info@cooluli.com) for more information.

## **How can I get a replacement cord?**

Cooluli replacement cords are available on Amazon and on our website, [Cooluli.com](http://Cooluli.com).

## **Where are Cooluli coolers/warmers made?**

Cooluli is an American company based in Brooklyn, NY and our products are custom-manufactured in China.

# BASIC TROUBLESHOOTING

The most common issues experienced by Cooluli users are caused by voltage incompatibility. The following issues give an overview of possible errors and instructions of how to check the unit.

| Concern                                                                                                                                         | Possible Reason                                                                                                                                                                                                                                                                                                                                                | Check                                                                                                                                                                                                                                                                                                                                                                              |
|-------------------------------------------------------------------------------------------------------------------------------------------------|----------------------------------------------------------------------------------------------------------------------------------------------------------------------------------------------------------------------------------------------------------------------------------------------------------------------------------------------------------------|------------------------------------------------------------------------------------------------------------------------------------------------------------------------------------------------------------------------------------------------------------------------------------------------------------------------------------------------------------------------------------|
| Blinking green light in the back of unit.                                                                                                       | Unit fan not rotating.                                                                                                                                                                                                                                                                                                                                         | Contact Customer Support for assistance. Consult this <b>Instruction Manual</b> or go to <a href="mailto:info@cooluli.com">info@cooluli.com</a> for contact information.                                                                                                                                                                                                           |
| Fan making a loud noise.                                                                                                                        | Check for fan obstruction or failure.                                                                                                                                                                                                                                                                                                                          | Check the back to see if there is at least a 2-inch clearance around fan and vents. If issue persists, contact Customer Support.                                                                                                                                                                                                                                                   |
| Unit doesn't cool contents as advertised.                                                                                                       | Most Cooluli units cool contents down anywhere from 35° to 40° below ambient temperature.                                                                                                                                                                                                                                                                      | Consult your unit's specific cooling information found in this Manual. If cooling temperature is significantly less than what is listed for your unit, contact Customer Support.                                                                                                                                                                                                   |
| Unit not cooling and lights off in back.<br><br>Unit stopped working                                                                            | Main power source failure.                                                                                                                                                                                                                                                                                                                                     | Check outlets first.<br><br><b><u>If unit not turning on in your home/office:</u></b> Try plugging the unit into your car using the included DC power cord.<br><b><u>If unit not turning on in your car/motor vehicle:</u></b> Try plugging the unit into a 100-240 volt outlet in your home/office using the included AC power cord. If issue persists, contact Customer Support. |
| Ice is building inside the unit, around the center screws in the back.<br><br>Water collecting at bottom of unit.<br><br>Water drip or leakage. | Check that the door is clean and free from obstruction and is closed securely.<br><br>Water condensation. It is normal for thermoelectric units, while in cooling mode, to produce water droplets that may freeze in the back and then melt.<br><br>Water condensation is normal in thermo-electric units. Check if water accumulation is due to condensation. | While the unit is off and at room temperature, take a soft cloth and gently wipe down the inside of your unit to remove any moisture that may accumulate. This is recommended once or twice a week.<br><br>If issue persists, contact Customer Support for further assistance.                                                                                                     |



**For further assistance please contact  
Cooluli Support:**

COOLULI

ATTN: Customer Support

1425 37th St Suite 213

Brooklyn NY 11218

Phone: (646) 787-1104

Email: [info@cooluli.com](mailto:info@cooluli.com)

# WARNING

**PLEASE READ THESE DIRECTIONS CAREFULLY BEFORE USING THIS COOLER/WARMER UNIT TO ENSURE PROPER OPERATION. IMPROPER USE, INSTALLATION, ADJUSTMENT, ALTERATION, SERVICE OR MAINTENANCE CAN CAUSE INJURY OR PROPERTY DAMAGE.**

1. To ensure optimal performance, keep the cooler/warmer unit's fans clear of dirt and debris. Stuck fans will overheat the unit and can pose a potential fire hazard.
2. Do not place any cloth or paper products on the unit.
3. When plugging in the unit, ensure that the power cord is inserted tightly into the socket. A loose socket can cause damage or fire.
4. When using the unit in a car/vehicle with the DC power cord, the vehicle's engine must be turned on first. When the engine is running, the unit can then be plugged into the vehicle's adapter. This prevents a power surge and potential property damage, injury, and/or fire.
5. Keep the unit away from flammable items and running water to prevent damage, injury, and/or fire.
6. DO NOT attempt to open, break, or refit the appliance.
7. This unit works in 100-240V (in compliance with worldwide standards).
8. To switch temperature control, the unit must be turned to the OFF setting for 30 minutes before shifting the unit from COLD to HOT.
9. DO NOT submerge or rinse under running water.
10. When packing the unit, do not place upside-down.
11. Avoid dropping or banging the unit.
12. DO NOT leave the appliance in the rain.
13. Adult use and supervision only. This is not a toy. Children should not play with this cooler and warmer unit. For people with reduced physical, sensory, and/or mental capabilities, use precaution and follow all instructions when operating this unit to ensure safety.
14. Always keep ventilation openings clear of obstruction.
15. DO NOT use other electrical appliances inside the food storage compartments of the appliance.
16. If the power cords supplied with the cooler and warmer unit are damaged in any way—DO NOT attempt to repair them; damaged power cords must be replaced by the manufacturer.





*Cooluli*®  

[www.cooluli.com](http://www.cooluli.com)

Distributed by Cooluli®  
New York, NY 11218  
Made in PRC  
Cooluli™ is a trademark of  
LISSE USA LLC  
(718) 834-5312  
Copyright ©2018 all rights reserved