



ENVIRO  
BUILD

INSTALLATION & MAINTENANCE GUIDE

# HYPERION

D E C K I N G

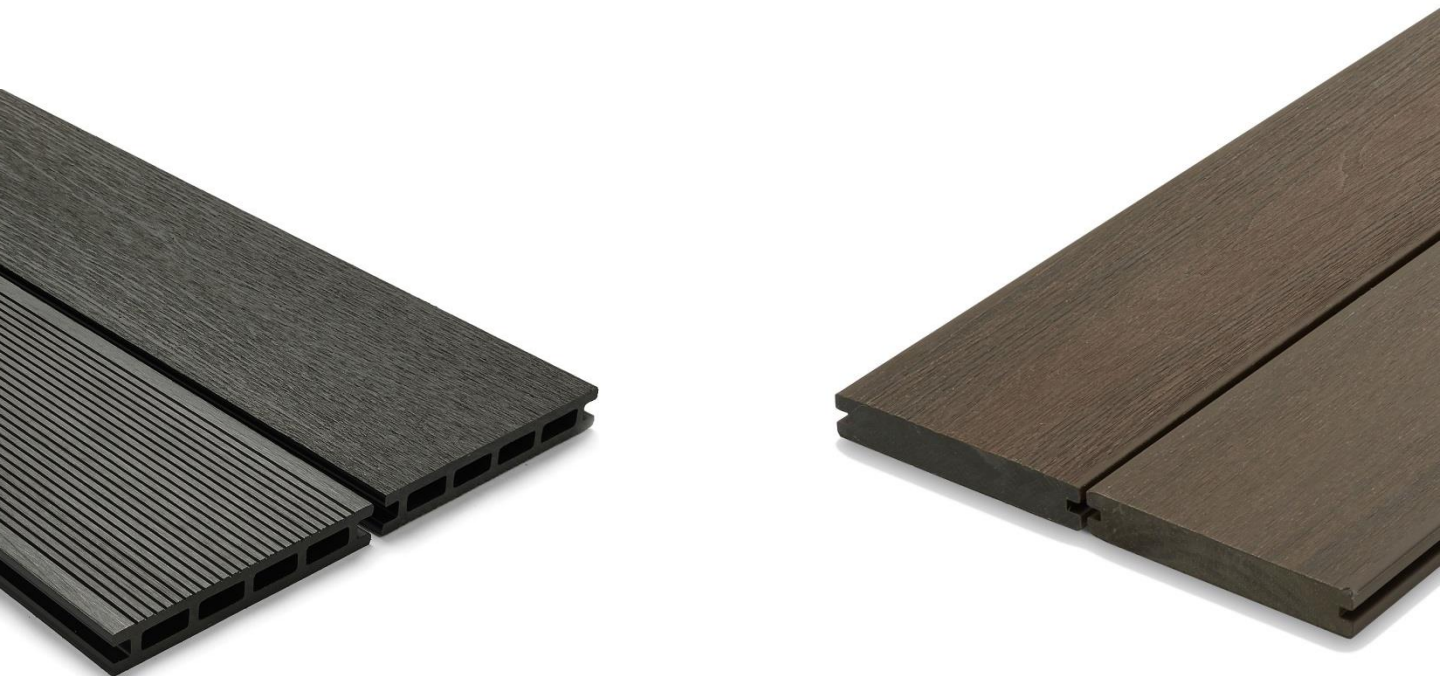

[ENVIROBUILD.COM](http://ENVIROBUILD.COM)



+44 (0) 208 088 4888

Version 3.7

©EnviroBuild 2018



# CONTENTS

---

03	Storage & Handling
04	Tools
05	Calculating Materials
07	Accessory Recommendations
08	Sub-frame Installation Overview
09	Sub-frame On Hard Concrete and Flat Roofs
11	Sub-frame On Soft / Non-Concrete Foundations
13	Spacing Composite Materials
14	Decking Installation Steps
15	Installing The Last Deck Board
17	Diagonal Decking Installation
18	Picture Frame Boarder Installation
20	Bullnose Board Installation
21	Installing Edge Step Boards
23	Finishing Steps – Fascia Boards
24	Finishing Steps – Corner Trim
25	Installing Steps & Stairs
27	Maintenance & Care
28	FAQs





## STORAGE & HANDLING

While composites are highly durable, to ensure their lasting beauty, please follow these important guidelines when storing, moving and working with Hyperion Decking products.



### Storage

- Material should always be covered until it is ready to be installed to maintain a clean surface. If stored outside use a non-translucent material
- All products should be stored flat and level, supported above the ground at 500mm intervals
- Battens used to separate and support any stored decking material should be spaced no more than 500mm apart, to ensure the boards don't bow
- Stack units with banding and bottom supports aligned
- Pallets of decking boards should not be stacked more than 4 pallets or 3m in height



### Handling

- Hyperion Decking materials should be placed and not dumped when unloading
- When removing boards from a unit, lift the boards and set them down, do not slide boards against each other when moving them
- Carry Hyperion Decking boards on the edge for better support
- During construction, do not slide or drag any equipment across the boards
- The surface of the boards should be kept free of construction material and waste to prevent damage
- Each 4m decking board can weigh between 9.5Kg and 14.5Kg, please ensure they are handled safely. we recommend that two people handle the boards during transportation







## Recommended Tools To Install Hyperion Decking

Standard woodworking tools can be used when working with Hyperion Decking. If you are unsure on how to use any tool, please consult the tool's manufacturer's user manual.

- Circular Saw - we recommend a thin kerf 40-tooth alternate top bevel finish blade to achieve the cleanest cuts. If cutting Manticore plastic lumber use a tungsten carbide blade (small metal fragments can get through the recycling process).
- Power Mitre Saw can also be useful for efficiency and bevelled edges
- Jig Saw
- Hand Drill - 3mm and countersink drill bits (can use all-in-one smart bit)
- Impact Driver (Use T15 secure drill bit supplied in all Hyperion hidden fastening packs, use low torque setting)
- Tape Measure
- Carpentry Square
- Spirit Level
- Safety Glasses and relevant Personal Protection Equipment (PPE)
- Chalk Line





## CALCULATING MATERIALS

To determine how much Hyperion Decking material will be required, you can either use detailed plans or follow the method below. Alternatively, feel free to use our [online calculator](#) or speak to one of our technical experts on 0208 088 4888.

fig.01

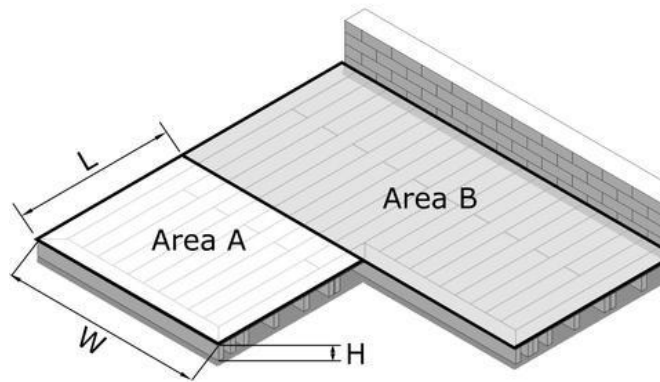

- 1 Start off by measuring the width and length of your proposed decking area(s)
- 2 Plan which direction to lay your decking

The following example will use a decking area of 3m wide x 6m long and 4m Pioneer decking boards (145 x 21mm) with 6mm hidden fasteners:

fig.02

Range	Board length (m)	Board width (mm)	Board Depth (mm)
Pioneer	2.2m & 4.0m	145mm	21mm
Frontier	4.0m	143mm	22mm

- 3 If the boards are laid lengthways, to find the number of board rows, divide the deck width by the width of the board (**fig.02**) plus a 6mm spacing per board (allows for the hidden fastener gap)
 

**3m width / (0.145m + 0.006m) = 20 boards wide**
- 4 Now multiply the length of the deck by the number of boards wide (given above). This gives you the total linear meters of deck boards required:
 

**6m length x 20 boards wide = 120 linear meters**
- 5 Finally, divide the total linear meters of decking by the length of board being used:

**120 linear meters / 4m board length = 30 lengths of 4m decking boards**





## CALCULATING MATERIALS

fig.03

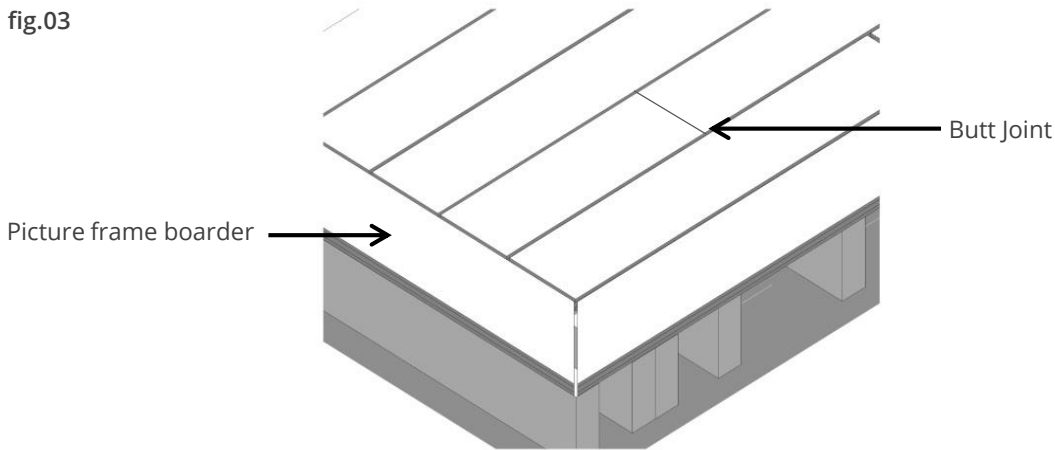

### Picture Frame Border

- 6 If you plan to have a 'picture frame' border (**fig.03**), add on the length of the boards running against the overall board direction (then divided by the length of the decking board used)

**Total length of sides = 3m x 2 sides = 6 linear meters**

**6 linear meters / 4m length decking board = 1.5 boards; then always round UP to 2 boards**

### Calculation Recommendations

- It is recommended that you add at least 5% to the total material required for a wastage factor. It is unlikely you will use the board lengths perfectly
- For diagonally laid decking it is recommended that you add 15% extra material as you will generate more scrap from cutting. To read more on diagonal deck installation see **p.20**
- A drawing to scale may help you determine how much more material will be required
- If you do not want butt joints (example shown in **fig.03**) across the deck and the width is no greater than 2.8m, then you need to ensure you order enough extra 4m boards to cover the area
- Always round UP the number of boards required
- For multiple decking areas, follow the steps for each above and sum the quantities together





# ACCESSORY RECOMMENDATIONS

For fixings, finishing's and substructure the below guide will help determine how much you may require

## ACCESSORIES

Item	Product	Profile (mm)	Size Options	Colour Options	Quantity per M2
	Pioneer Fascia Board	72 X 12	2200mm	As per Pioneer range	Var.
	Frontier Fascia Board	140 X 12	2200mm	As per Frontier range	Var.
	Frontier Bullnose	143 X 22	4000mm	As per Frontier range	Var.
	Pioneer Edge Board	54 X 54	2200mm	As per Pioneer range	Var.
	Pioneer Corner Nosing	54 X 40	2200mm	As per Pioneer range	Var.
	6mm Hidden Fasteners		Box of 100	Black	20 Clips
	3mm Hidden Fasteners		Box of 100	Stainless Steel	20 Clips
	Starter Fasteners		Box of 50	Black	4 Clips

## SUBSTRUCTURE

Item	Product	Profile (mm)	Size Options	Colour Options	Quantity per M2
	Manticore Plastic Joists	50 X 50 50 X 100 50 X 150	3100mm 3400mm 3400mm	Black	4m per m2
	Manticore Plastic Posts	100 X 100	3400mm	Black	0.5m per m2
	MESA Joist Cradle Riser	110mm ring 90mm base	10-40mm height rise	Black	8 per m2
	MESA Adjustable Pedestals	140mm head 200mm base	Heights from 12 - 595mm	Black	4 - 9 per m2

These are best estimates only, for more complex designs and features, a drawing to scale may help you determine how much material will be required.



## SUB-FRAME INSTALLATION OVERVIEW

Hyperion Decking can be installed on various sub frame choices; treated timber or plastic lumber anti-rot joists. For all types of sub frame you must adhere to the following rules to ensure the warranty validity

### Before You Start

- The joists are designed to take live loads, any static loads must be placed over the supports
- **Only use tungsten carbide tipped drill bits and saw blades for working with plastic lumber, we do not recommend diamond tipped blades** (small metal fragments can get through the recycling process)
- To allow sufficient drainage a drainage slope of **0.5% (5mm per meter)** should be incorporated
- Due to temperature induced expansion and contraction with plastic lumber, you should never fix bearers directly to foundations; if you have to fix the bearers to the foundations, use expansion clips.
- Plastic bearers should be installed with the greatest dimension as the upright
- The bearer must not overhang a support by more than 50mm
- Where lumber ends abut a cross beam, you must leave min. 10mm gap from the bearer end to the cross beam. These can be joined using expansion L-brackets over a support or joist hangers
- A joist must be used under deck board ends, and a double joist structure for deck butt joints (**fig.02**)

### Spacing & Supports

The range of decking you use will determine the joist centres used for the project. Ensure widths between joist centres are no greater than below table:

fig.04

Hyperion Range	Max. Support Span	Diagonal Support Span
Pioneer	300mm	250mm
Frontier	400mm	300mm

If you plan on using Manticore Plastic lumber the height dimension of the bearer will determine how often the joist need to be supported. Ensure widths between supports under joists are no greater than below:

fig.05

Plastic Lumber Bearer Profile	Max. Support Span
50x50mm	500mm
50x100mm	750mm
50x150mm	1500mm







## SUB-FRAME ON HARD CONCRETE & FLAT ROOFS

With solid flat foundations and flat roof areas the decking substructure can be supported with adjustable support pedestals (**fig.06**). These are simply placed straight onto the ground with a protective rubber pad (flat roofs) and the height of each is adjusted by rotating the pedestal top.

### Preparing The Area

- The foundations should incorporate a drainage slope of 5mm per meter to avoid water pooling
- The installation condition should be flat and stable in order to avoid deformation of the decking surface
- A gutter or scupper should be made in the foundations
- Composite boards must be a min. of 50mm off the ground (**fig.07**)
- In areas of potential excessive water and debris build up, we recommend either Manticore plastic bearers or min. 90mm off the ground for pressure-treated timber joists to ensure good air ventilation and water passage

### Roof Terrace Preparation

- Ensure the roofing membrane is 100% water tight and free of debris
- On flat roofs, protective rubber mats should be placed under pedestals to avoid damaging the roofing membrane (**fig.06**)
- Where a waterproof membrane is in place, pedestals cannot be bolted to the ground; the weight of the decking should be sufficient to keep all in place

fig.06

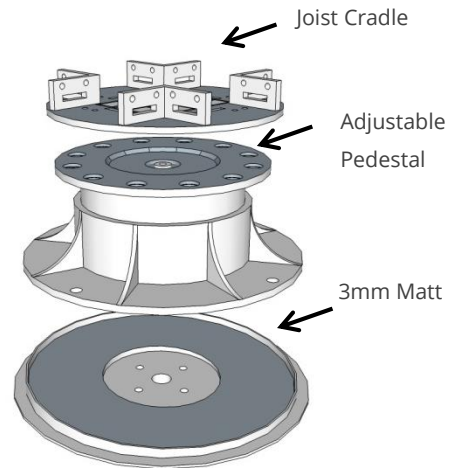

fig.07

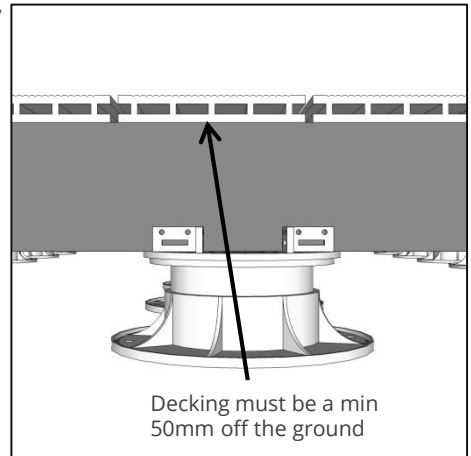
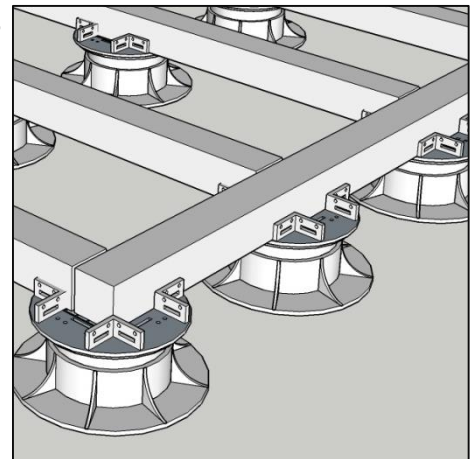

fig.08





## SUB-FRAME ON HARD CONCRETE & FLAT ROOFS

### Laying The Pedestals

- 1 Starting from the edge of the decking area, lay out the pedestals (**fig.09**)
  - Rotate the base clockwise to increase the pedestal height to your required size (**fig.10**)
  - Your joist size will affect how often you need to lay the pedestals (**fig.05**)
  - In corners or along edges where the top of the pedestal cannot fully support the joist, you can simply turn the pedestal upside down
- 2 For roof terraces it is recommended to use the rubber base mats to provide an extra layer of protection
- 3 Use a spirit level to check the level of the pedestals
- 4 To take account of a slope in the foundations, joist cradles can be used that can correct for the incline

### Laying The joists

- 5 After laying the pedestals (**fig.09**), starting from the edge of your sub-frame, place the bearers on top of the pedestal centres
- 6 Ensure that each bearer/ joist is supported in a min. of 3 places, to the max. span as per **fig.05**. The decking range used will also determine the joist centres (**fig.04**)
- 7 If you have a joist butt joint, joists can be laid end to end when supported on a pedestal . Ensure to leave a 20mm expansion gap between joists ends (**fig.10**)
- 8 A full joist width and clip must be used under each deck board end, thus you must ensure to have a double joist structure for deck board butt joints (**fig.11**)

fig.09

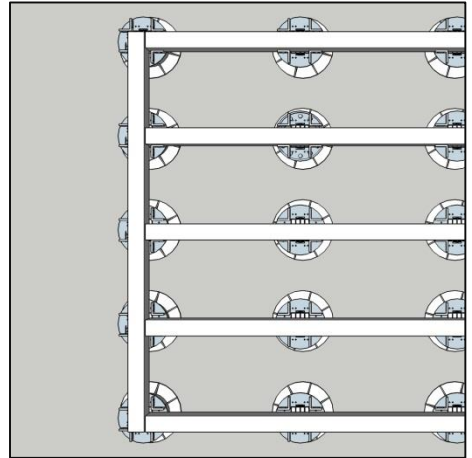

fig.10

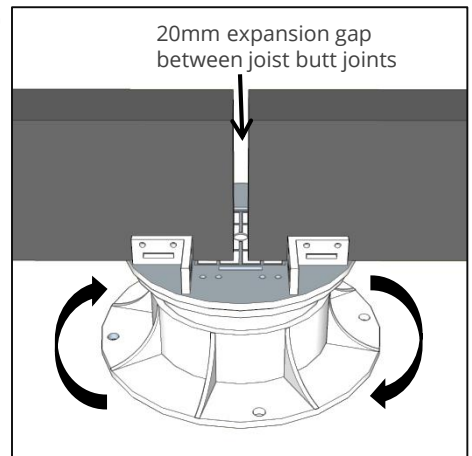
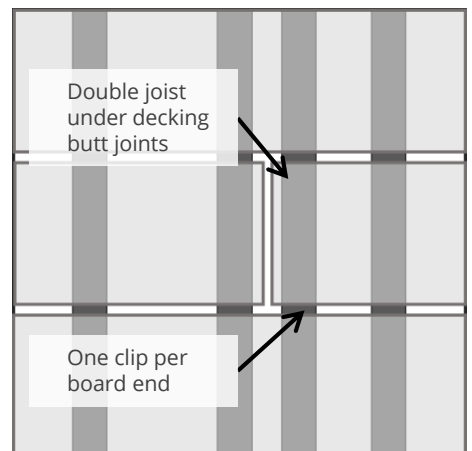

fig.11





## SUB-FRAME ON SOFT/NON-CONCRETE FOUNDATIONS

On soft ground, post supports are recommended to support your deck

### Preparing The Area

- Remove any top turf layer and scree/gravel should be laid to aid drainage; use weed control fabric to prevent plants growing below the decking
- Incorporate a drainage slope of 4mm per meter
- Composite decking must be a min. of 300mm off the ground when over soft ground
- Foundations must be higher than surrounding areas to avoid ponding

### Installing The substructure

- 1 After prepping your area, start from the edge of the sub frame and plant you posts into the ground. These need to be cemented into the ground a min. of 500mm or a third of the total post height (**fig.12**)
- 2 Once set, you can attach the joist frame. Joists should be attached using good quality galvanised mushroom capped bolts which penetrate both the bearer and the upright post; typically with countersunk nuts where appropriate (**fig.13**)
- 3 Ensure that each bearer/ joist is supported in a min. of 3 places, to the max. span as per **fig.05**. The decking range used will also determine the joist centres (**fig.04**)
- 4 When using plastic lumber, bolt holes should be oversized by 3mm to allow for expansion and contraction (**fig.04**)

fig.12

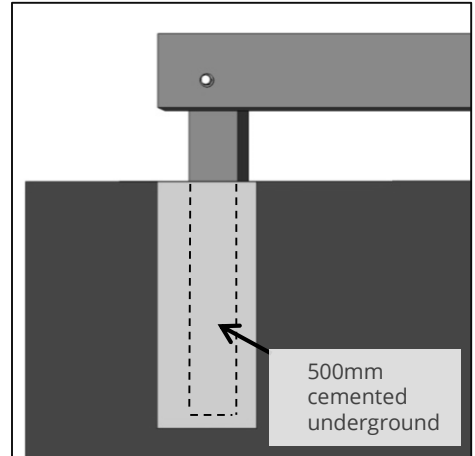

fig.13

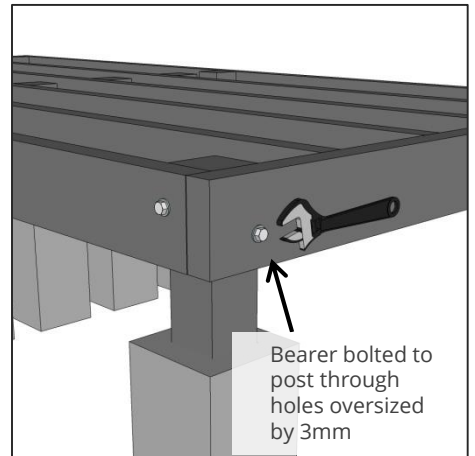
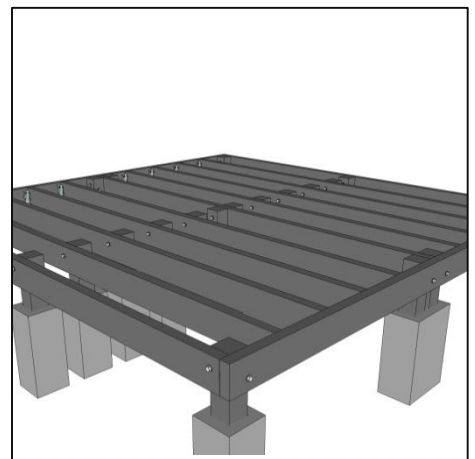

fig.14





## SUB-FRAME ON SOFT/NON-CONCRETE FOUNDATIONS

- 5 To strengthen the deck and reduce the amount of posts required, you can use joist hangers to hold joists to cross beams (**fig.15**)
- 6 When using Manticore plastic lumber, where the joist end meets a cross beam, you must leave min. 10mm gap to allow for joist expansion (**fig.16**)
- 7 At butt joints the deck board ends should not share a single joist, each deck board end must be supported by a full joist. For deck board butt joints you must ensure to have a double joist structure underneath. For deck board butt joints you must ensure to have a double joist structure underneath. (**fig.17**)
  - One hidden fasteners should be per board end at butt joints . Butt joints should not share one clip (**fig. 17**)

fig.15

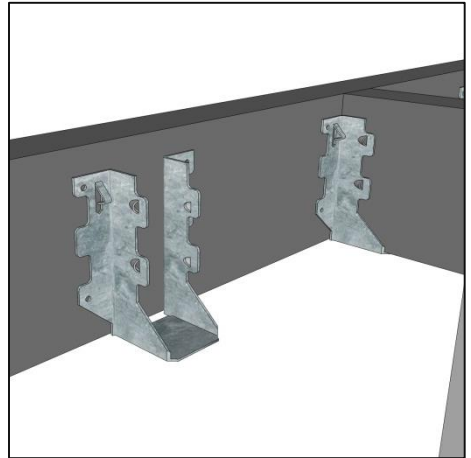

fig.16

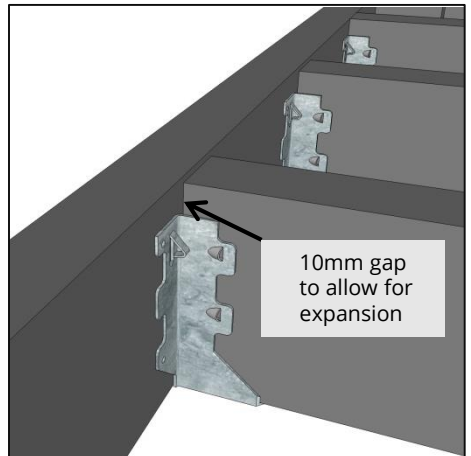
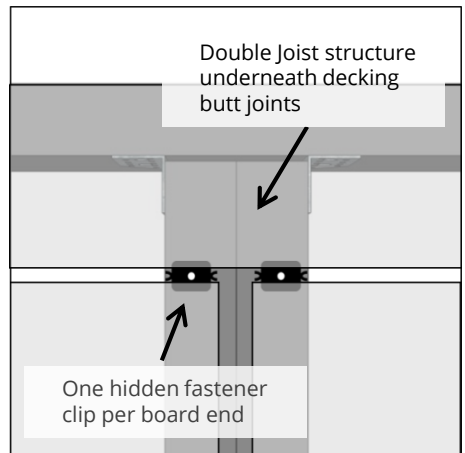

fig.17





## SPACING COMPOSITE MATERIALS

Please ensure the correct sized 3mm pilot holes (when using Hyperion secure screws) are pre-drilled before screwing into all composite products to avoid splitting. The length of the hole must be at least the same length of the screw

### Spacing The Boards & Sub-Frame

Due to natural expansion and contraction of material with changes in temperature, please ensure the following gapping requirements for all Hyperion Decking products:

- Hyperion Decking boards should have a min. 3mm gap side to side
- Hyperion Decking board butt joint should have a min. 8mm gap end to end
- Plastic lumber joist butt joint should have a min. 20mm gap end to end
- A min. 20mm gap is required when abutting walls or other fixed objects
- Hyperion Decking boards should not overhang joists by more than 20mm
- To ensure sufficient water run-off a drainage slope of 0.5% (5mm per meter) should be incorporated

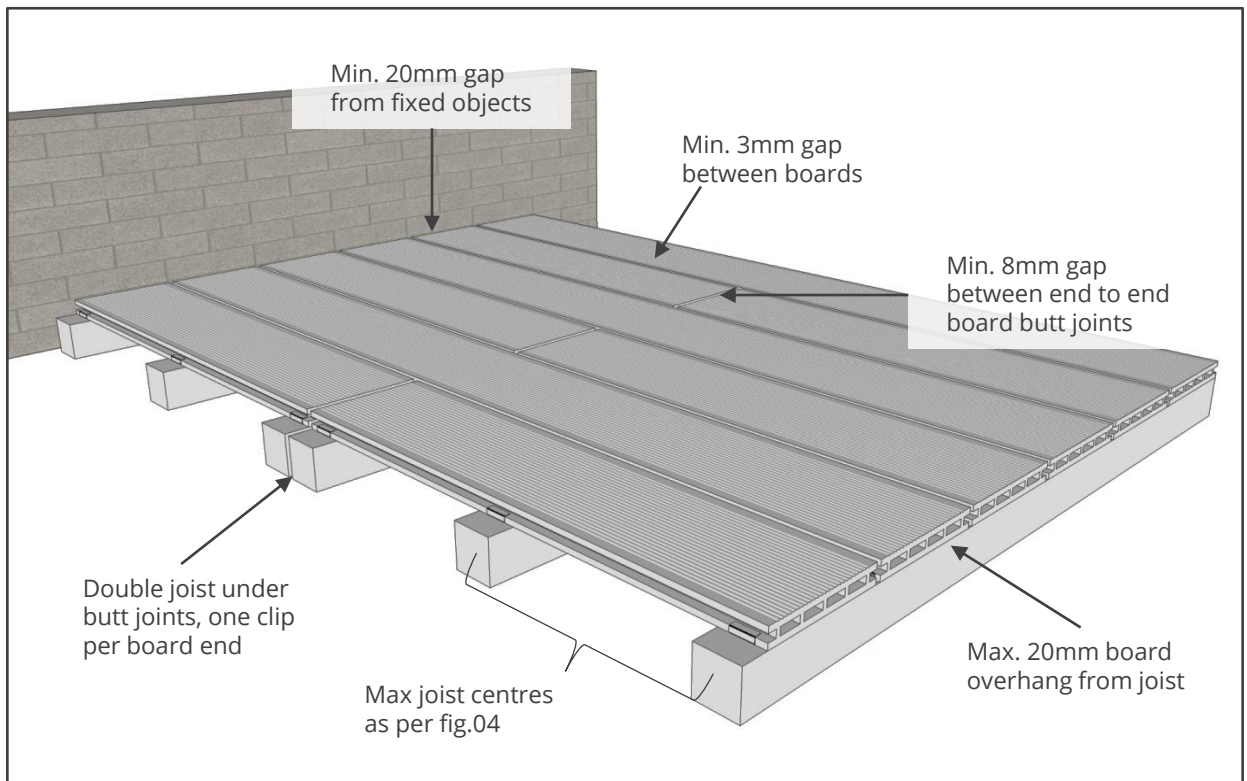





## DECKING INSTALLATION

With your sub frame levelled and stable, you can now start installing your deck boards. If you are installing Frontier Bullnose Edging (p.18-20) or Pioneer Edge board (p.21-22) it is recommended to install the corner trimmings before installing the deck boards.

### Installing The Deck Boards

- 1 The first board must be fixed with Hyperion hidden starter fasteners that will clip to the side groove of the board (fig.18)
  - Align the starter fasteners along the first joist, every 300mm along the joist length
  - Securely screw each fastener to the joist
  - Simply clip the first decking board to the starter fasteners (fig.19)
- 2 To fix adjacent boards, place Hyperion hidden fasteners (3mm or 6mm) into the grooved edge of the fixed board and insert the secure screw into the hidden fasteners (fig.20)
  - Screw holes should be lined up with joist centres
  - Ensure the counter sunk section of the hidden secure fastener is facing up
  - Install 1 hidden fastener on each joist
  - Always use hidden fasteners at board ends
  - Use 1 fastener per board end at butt joints (never share a fastener across 2 board ends)
- 3 For 6mm plastic hidden fasteners, lightly screw in place, do not tighten at this point (fig.20).
  - For 3mm metal hidden fasteners, fully tighten the screw at this point

fig.18

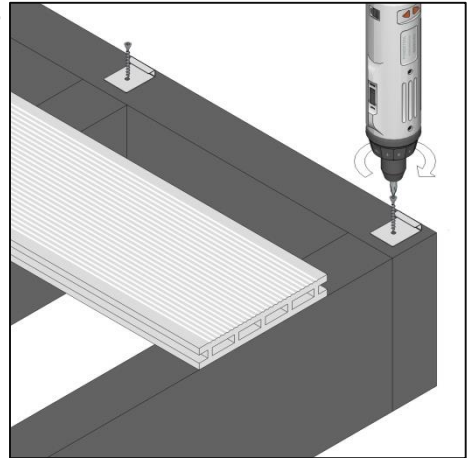

fig.19

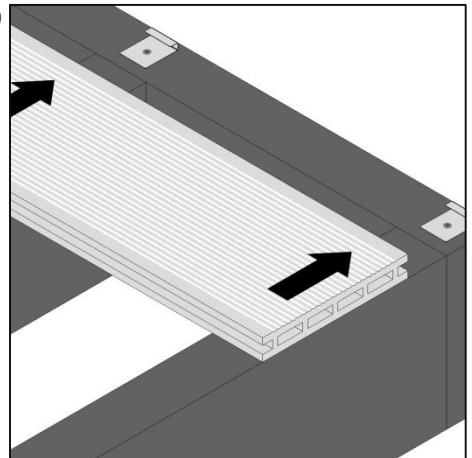
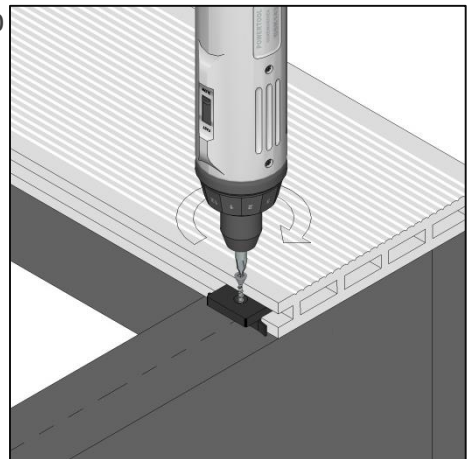

fig.20





## DECKING INSTALLATION

- 4 Place the next board into position against the hidden fasteners (**fig.21**)
- Slightly raise the outer edge of the board being installed and slide it onto the hidden fastener
  - Ensure the decking board edge contacts the spacer tab
  - Lightly tap into position if required

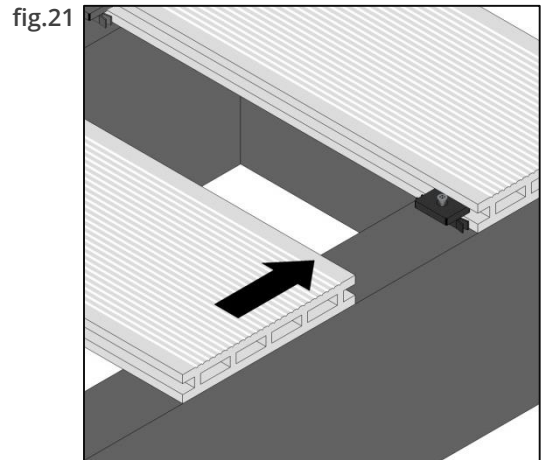

- 5 Fully tighten the hidden fasteners, between the last boards installed, down to the joists (**fig.22**)
- Apply sideward pressure on the decking to ensure that the tabs are hard up against the inside of the decking groove

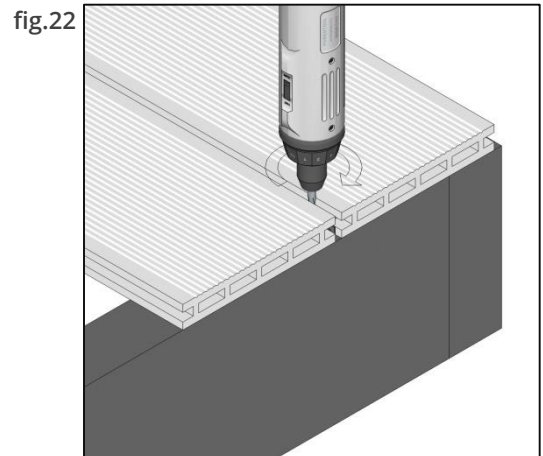

- 6 Repeat Steps 2 - 5 until you have reached the last 2 boards (**fig.23**). The last board can be fixed in 1 of 2 ways outlined on the next page

- 7 If you plan on using Edge Boards to finish your project skip to **Page 21**, or if you plan on installing a 'picture-frame' boarder then consult **page 18**

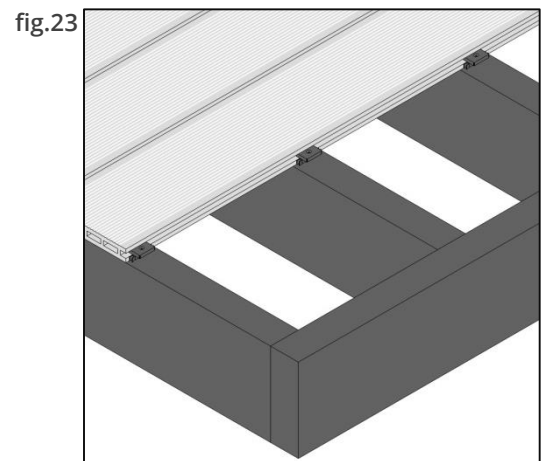



## INSTALLING THE LAST BOARD

### 6mm Hidden Fastener Method

Knowing the width of the last 2 boards including the 6mm spacing gap between them, mark on the last joist where the outer edge of the final board would lie

- Using these marks, install the hidden starter fasteners securely in place for the outer edge of the last board
- Clip the last decking board to these starter fasteners (**fig.24**)
- With the final board in place, insert the penultimate board.
- With the 2 boards in place and at least a 6mm gap between them, slide down the require number of 6mm hidden fasteners (**fig.25**)
- Secure the fasteners to the joists in between the last boards
- This option will only work with the 6mm hidden fasteners. If you are planning on using the 3mm fasteners you must use the below method

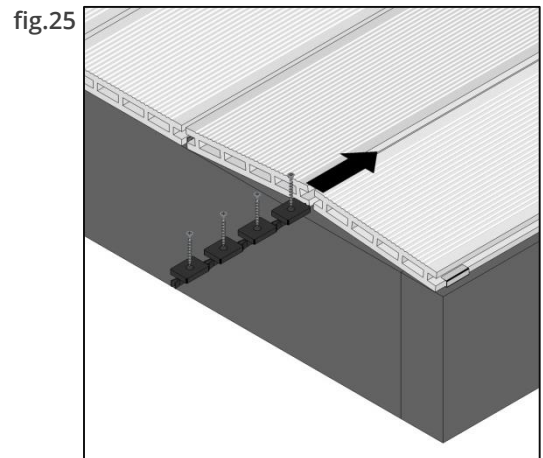
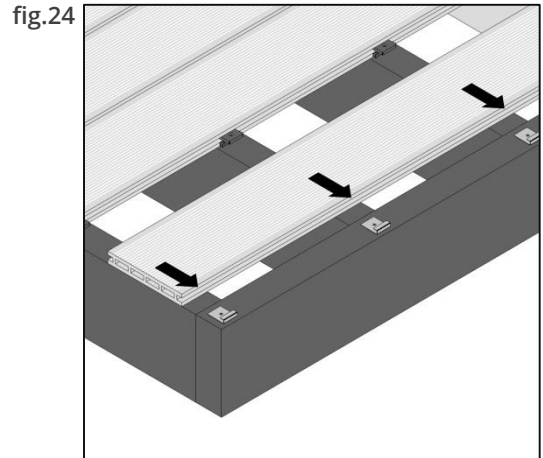

### 3mm Hidden Fastener Method

With the last board in place after securing all other boards, screw through the bottom edge of the last board at an angle, securing it to the joist at 300mm intervals (**fig.26**)

- Pre-drill pilot holes in the deck boards 2mm wider than the width as the screw shank
- Do not over drive screws into the deck boards to avoid the material splitting

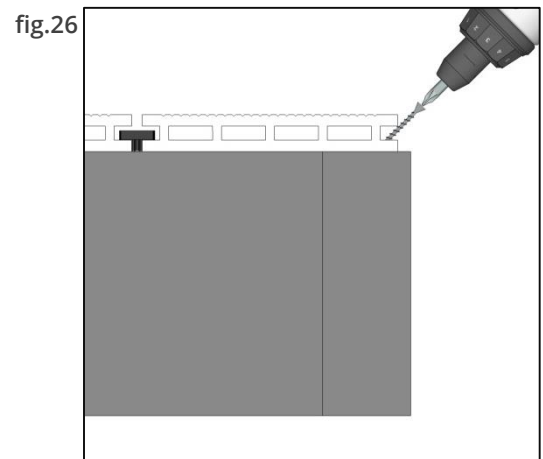



## DIAGONAL DECKING INSTALLATION

### Before you start

- Recommended joist centres for diagonal installation are 250mm.
- It is recommended that you add 15% extra material as you will generate more scrap from cutting

### Diagonal Decking Installation

- 1 Place the central board first; ensuring to place the board at a 45° angle (**fig.27**).
  - Install 1 hidden fastener each time the board crosses a joist.
  - Always use hidden fasteners to secure board ends
  - Use 1 fastener per board end at butt joints (never share a fastener across 2 board ends)
  - Use a mitre square to ensure an exact 45° angle
- 2 After laying the central board, progressively place each board outward toward the subframe corners (**fig.28**).
  - Boards offcuts can be kept used towards for finishing the corners.
  - Allow a slight overhang over the edge of the substructure
- 3 Once all boards have been fixed in placed, trim the deck board overhang with a circular saw (**fig.29**).
  - Complete the deck with finishing as per **p. 21-24**

fig.27

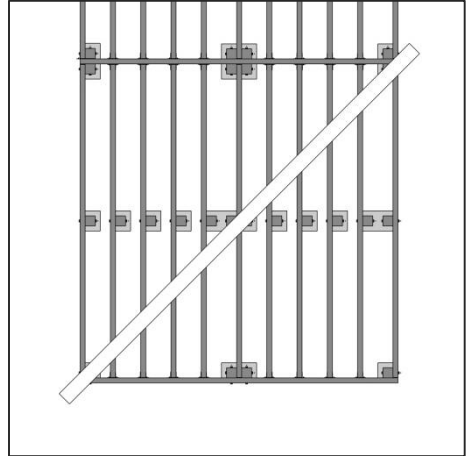

fig.28

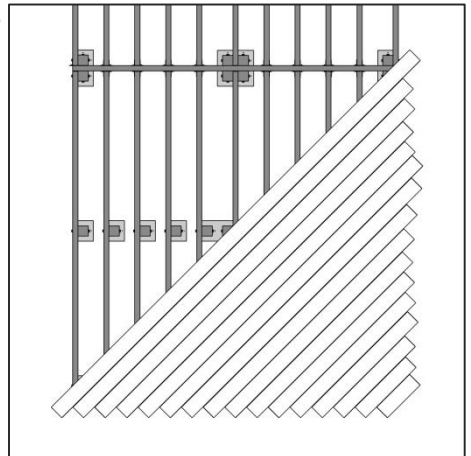
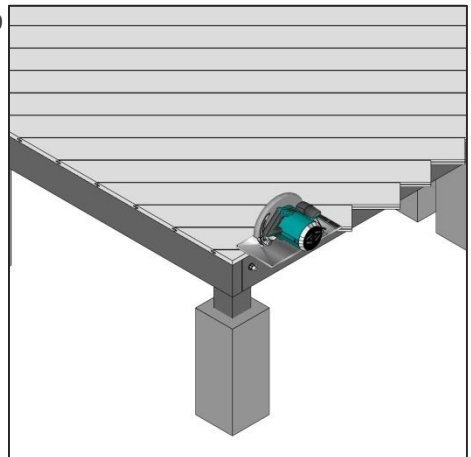

fig.29





## PICTURE FRAME & BULLNOSE BORDER INSTALLATION

If you are planning a picture frame border design (a board that runs around the perimeter of the deck) using either deck boards or Frontier Bullnose Edging you need to insure you install the correct substructure layout

### Picture Frame using deck boards

- 1 A full joist width must be used under each deck board end, thus where the picture frame board runs perpendicular to the main deck, you must have a double joist structure as per **fig.32**
- 2 Where the picture frame runs parallel you can install the board as per **Steps 1-6 (p15-16)** with a 45 degree mitred end as per **fig.31**
- 3 For the boards that run perpendicular to the main deck, place starter clips on the inner joist to hold the inner board edge in place (**fig.30**) . A clip should be installed every 300mm along the length of the joist.
- 4 Slide the picture frame board into the starter clips (**fig.31**)
  - You must leave the standard expansion gap between the mitred ends of the picture frame border
- 5 With the picture frame board in place, screw through it's outer bottom edge at an angle, securing it to the joist (**fig.32**)
  - Pre-drill pilot holes in the deck boards 2mm wider than the screw shank
  - Do not over drive screws into the deck boards to avoid the material splitting

fig.30

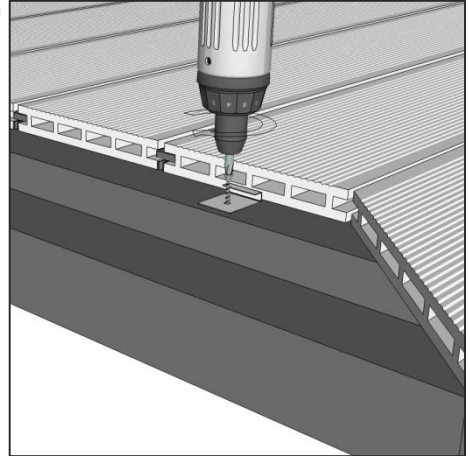

fig.31

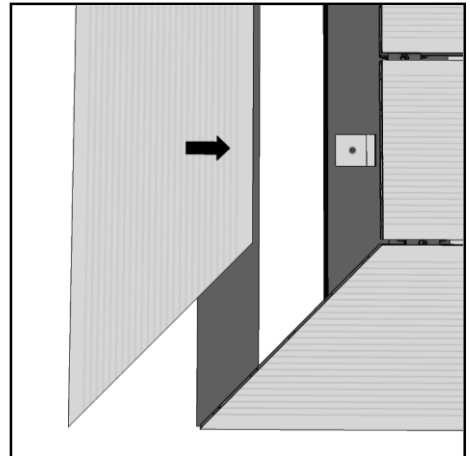
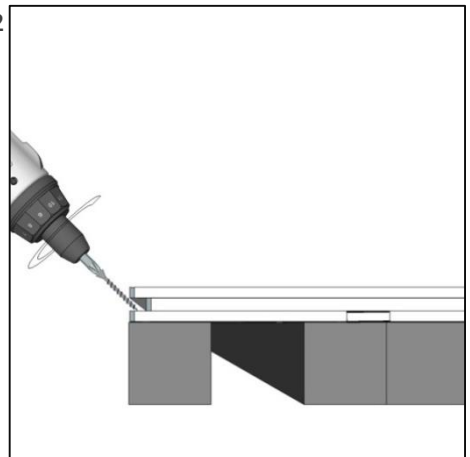

fig.32







## BULLNOSE BORDER INSTALLATION

### Picture Frame - bullnose boards

Hyperion Bullnose edging can be used with the hidden fastener system to create a flush finish for steps and deck board edges. There are two methods for installing the bullnose board, **parallel** and **perpendicular** to the decking

- Ensure to keep a 6mm expansion gap between edge board butt joints (min. 0.2% of the boards length)
- The bullnose must be installed **before** laying down the decking.
- This option is **only available in the Frontier range**

### Parallel Board Installation

- 1 Where fixing the bullnose boards around a corner, mitre the ends at 45 degrees
- 2 Secure starter fasteners onto the outer joist as per **(fig.33)** at 400mm intervals.
- 3 Line up the bullnose board and lay the underside groove directly on top of the starter fasteners. **(fig.34)**
- 4 Push the board forward to lock the board **(fig.35)**
- 5 Secure the remaining side of the bullnose board with hidden fasteners following **steps 1-6 (p14-15)**

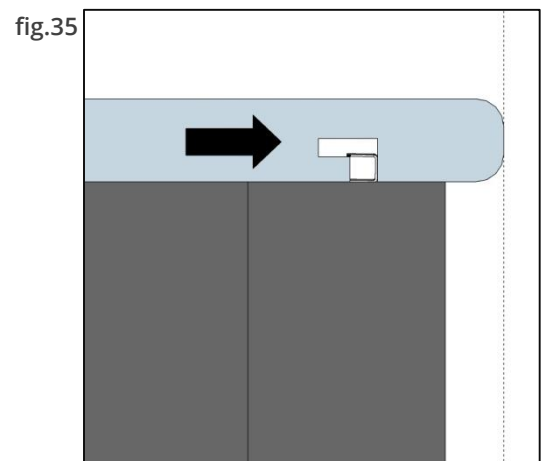
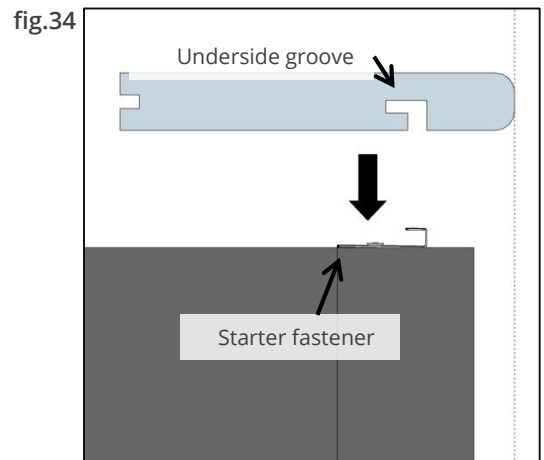
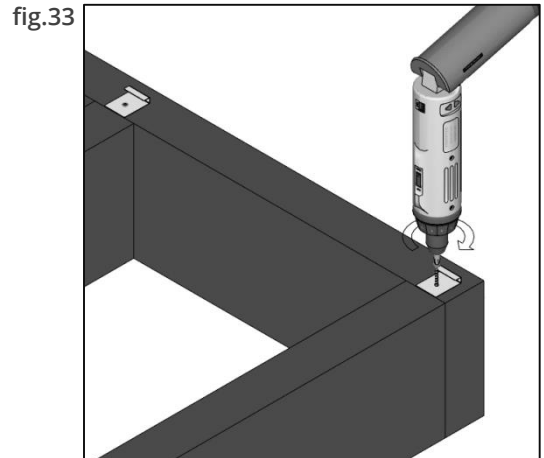



## BULLNOSE BORDER INSTALLATION - CONTINUED

### Perpendicular Board Installation

- 1 A full joist width must be used under each deck board end, thus where the bullnose board runs perpendicular to the main deck, you must have a double joist structure as per **fig.36**
- 2 Secure starter fasteners onto the outer joist as per **(fig.37)** at 400mm intervals
- 3 With the bullnose board in place, screw through the hidden fastener groove at a 45° angle, securing it to the joist **(fig.38)**
  - Pre-drill pilot holes in the deck boards 2mm wider than the screw shank
  - Do not over drive screws into the deck boards to avoid the material splitting

fig.36

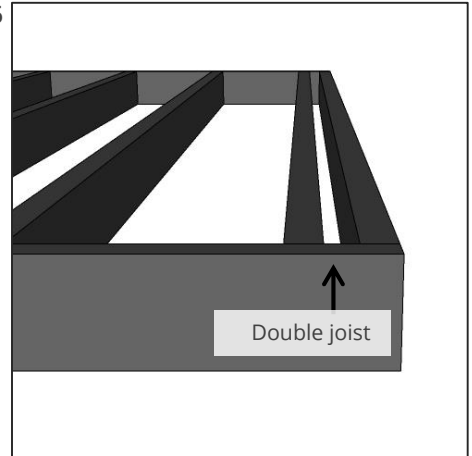

fig.37

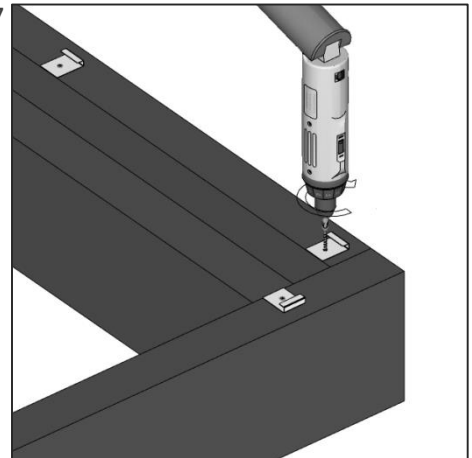
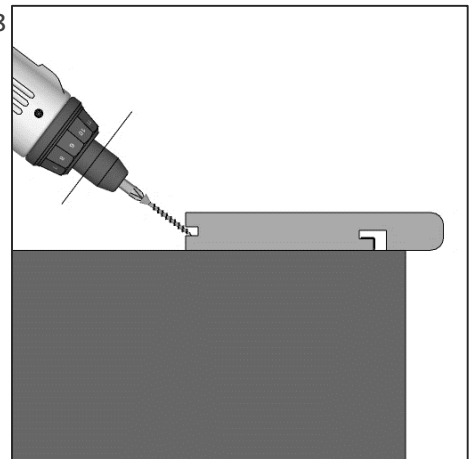

fig.38





## INSTALLING EDGE STEP BOARDS

### Option 1. Edge Board (Pioneer)

Hyperion edge boards can be used with the hidden fastener system to create a perfectly flush finish on deck edges and steps. There are two methods for installing the board, parallel and perpendicular to the decking

- Ensure to keep a 6mm expansion gap between edge board butt joints (min. 0.2% of the boards length)
- When using edge boards, use decking boards to complete the vertical deck skirting. Edge boards are not compatible with Hyperion fascia board
- This option is only available in the Pioneer range

### Parallel Board Installation

- 1 Where fixing the edge boards around a corner, mitre the ends at 45 degrees
- 2 Place the edge board over the edge of the joist and secure in place with Hyperion hidden fasteners at 300mm intervals (**fig.39**). Your chosen finish will affect the type of fasteners you should use to install the board:
  - If you are using a deck board for your fascia, use a 6mm or 3mm hidden fastener to secure the bottom of the edge board (**fig.39**)
  - If you are not planning to add fascia, you can use a starter fastener along the bottom edge (**fig.40**)
  - To secure the top side of the edge board with 6mm hidden fasteners, lightly secure down to the joist (**fig.41**), you will fully tighten once the next board is in place

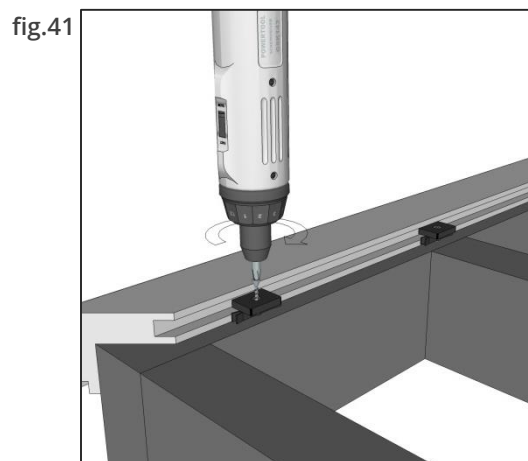
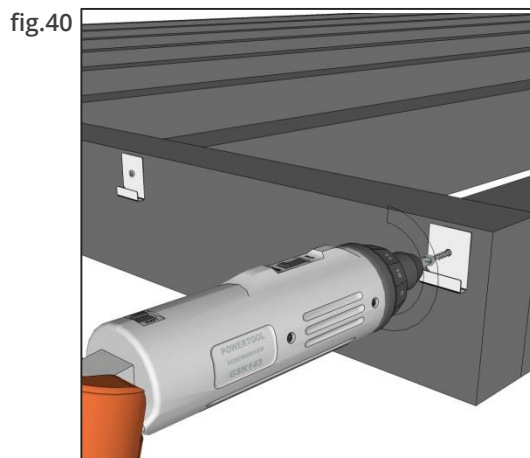
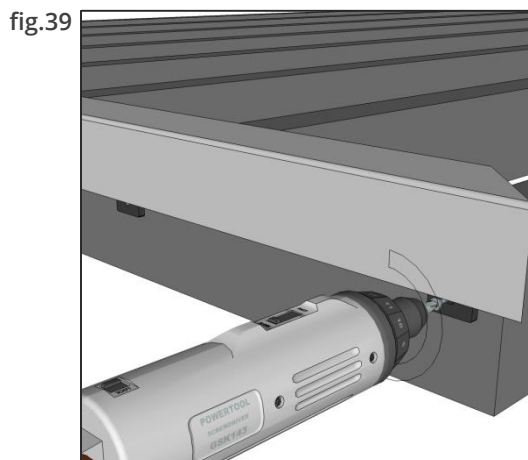



## INSTALLING EDGE STEP BOARDS

- 3 Once secured in place, slide the first deck board into the hidden fasteners (**fig.42**)

- 4 Fully secure the hidden fastener to the joist.

fig.42

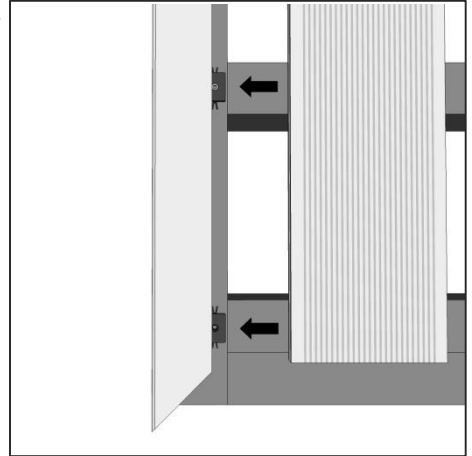

### Perpendicular Board Installation

- 1 Where fixing the edge boards around a corner, mitre the ends at 45 degrees

- 2 Install starter fasteners on the top side of the outer joist (the vertical clip edge should be 35mm from the outer joist edge). Starter fasteners should be installed every 300mm along the length of the joist (**fig.43**)

fig.43

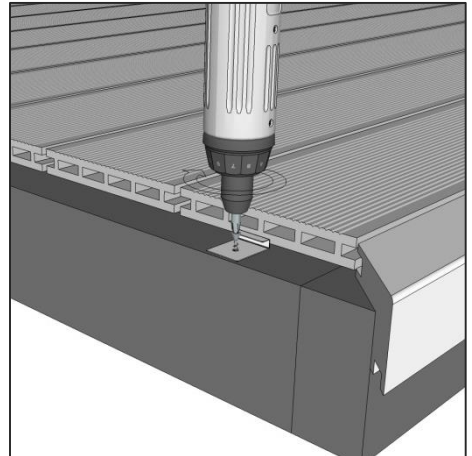

- 3 Clip the edge board into the starter clips (**fig.44**)

- 4 With the edge board in place, use hidden fasteners (3mm or 6mm) to secure the bottom side of the edge board

- Only secure lightly in place if you plan to install a deck board fascia then tighten once the first fascia board is in place

fig.44

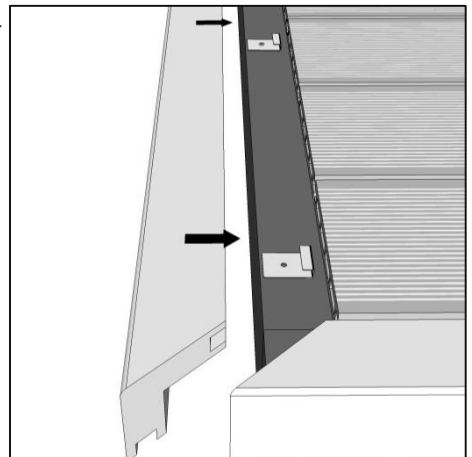



## FINISHING STEPS – FASCIA BOARDS

### Before You Start

You must ensure a suitable ventilation gap is left around the base of a deck allowing air flow when installing the deck skirting

- Hard / concrete foundations: min. 20mm gap
- Soft / non-concrete foundations: min. 40mm gap

fig.45

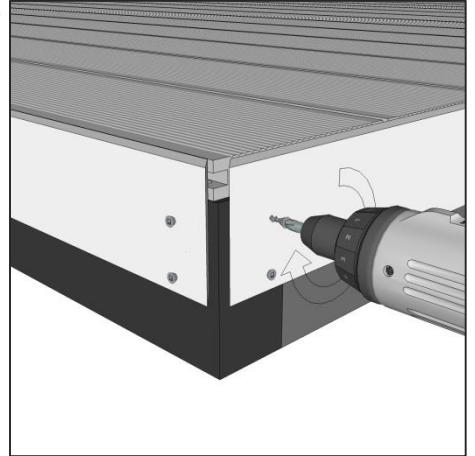

### Option 2. Fascia Board

Hyperion fascia boards can be used to skirt the visible deck edges in both Hyperion Decking ranges (**fig.47**). This option will result in visible screws in your deck skirting

fig.46

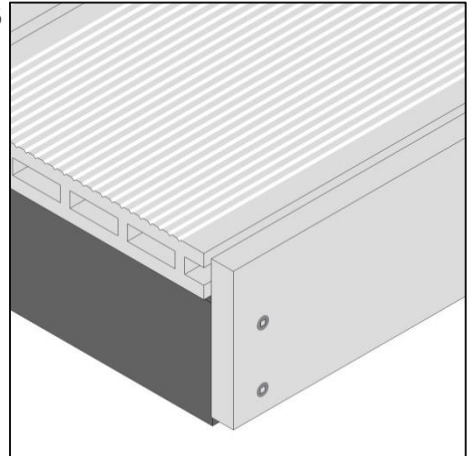

- 1 Line up the top fascia board edge with the top of the decking, to hide the grooved decking edge (**fig. 46**)
- 2 Pre-drill 4mm countersunk pilot holes through the fascia board to avoid material splitting (**fig.45**)
- 3 Fix in place with 50mm countersunk screws
  - Fascia boarding should only be screwed in place, it is not recommended to attach the boards using adhesive glue
- 4 Ensure you have left appropriate expansion gaps where fascia board ends meet, min. 0.2% the board length

fig.47

Range	Board Length (mm)	Board Width (mm)	Board Depth (mm)
Pioneer	2200	72	12
Frontier	2200	140	12







## FINISHING STEPS - CORNER TRIM

### Option 3. Corner Trim (Pioneer)

Hyperion corner trim can be used with Hyperion fascia and deck boards to cover exposed board sides and substructure. This option is only available in the Pioneer range and will result in visible screws

- 1 Measure the required amount of Hyperion corner trim and cut down to size, mitre down the ends at 45 degrees if installing around corners (**fig.48**)
- 2 Cover the deck edge with corner trim and attach with screws
- 3 Pre-drill 4mm countersunk pilot holes (**fig.49**)
- 4 Fix with 50mm countersunk screws (**fig.49**)
  - Do not overdrive screws when through composite products, finish tightening by hand
  - Corner Nosing should only be screwed into the deck. It is not recommended to attach the trim using glue.
- 5 Ensure you have left appropriate expansion gaps where corner trim ends meet, min. 0.2% the board length (**fig.49**)

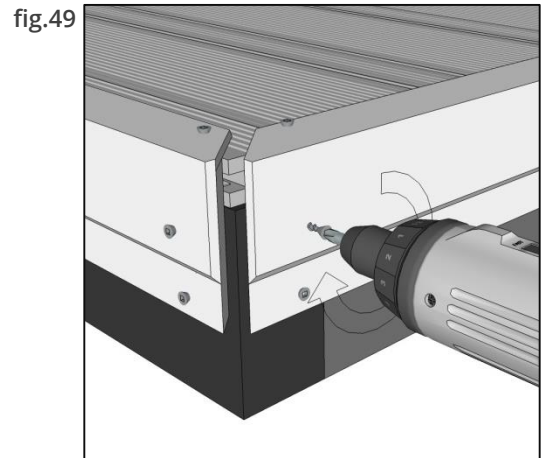
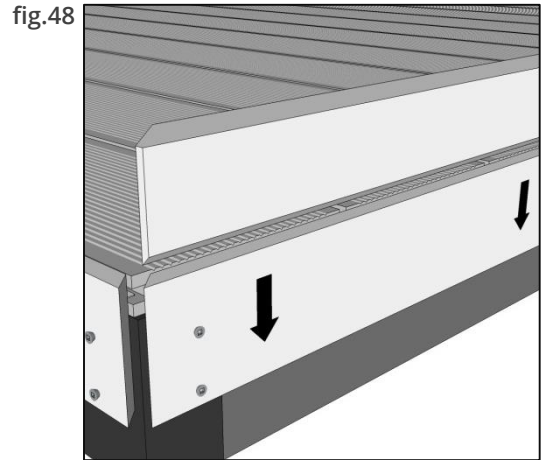

fig.50

Range	Board Length (mm)	Board Width (mm)	Board Depth (mm)
Pioneer	2200	54 X 40	4



## INSTALLING STEPS & STAIRS

### Before You Start

Steps must be min. 2 boards deep and max. 190mm high per step rise (220mm in private installations)\*\*

### Installing Deck Steps & Stairs

If creating the step support frame using Manticore plastic lumber it is recommended that you use 50 x 150mm profile bearers and only in a box frame structure (**fig.51**)

- 1 Plan your step area, taking into account the decking board and riser width, when designing the tread and rise dimensions
- 2 Create a box frame to support your step area (**fig.51**)
  - Ensure that the boards are supported at the appropriate joist centres
  - If you are creating multiple steps, ensure the base box is large enough to stack all steps on top (**fig.51**)
- 3 For multiple steps create additional smaller box frames and place on top (**fig.52**)
- 4 You can secure the separate box frames by inserting a post into the inner corner of the box frame and screwing in place (**fig.53**)

\*\* It is the customers responsibility to ensure the installation meets the stipulation of the minimum and maximum step rise, step going (depth) and pitch required, as per 'Document K: Building Regulations 1992'

fig.51

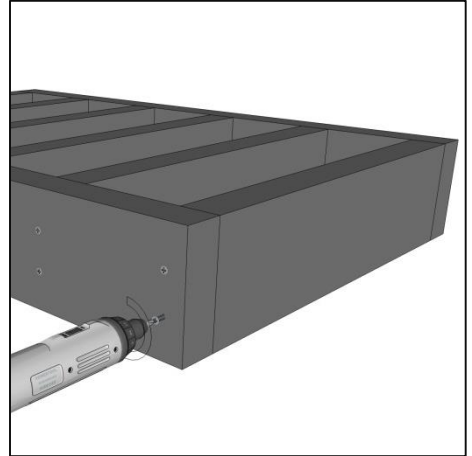

fig.52

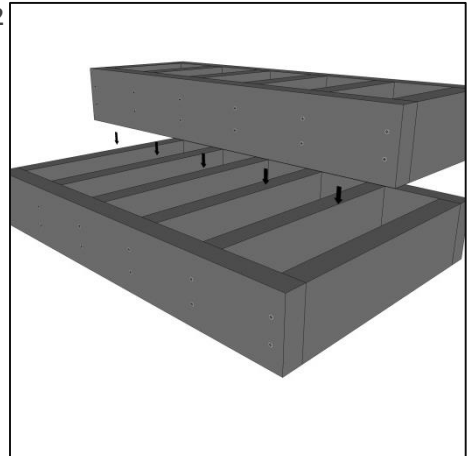
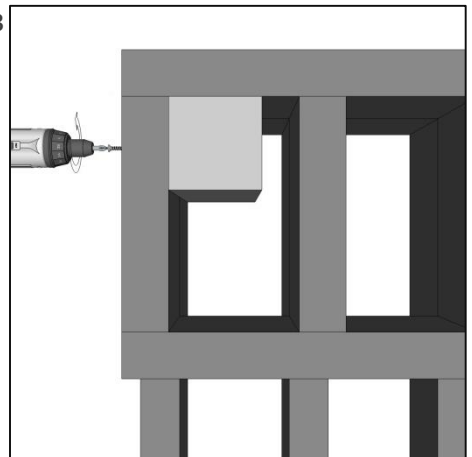

fig.53





## INSTALLING STEPS & STAIRS

Alternatively you can create a step stringers using appropriate width treated timber

- You must use min. 3 stringers, at max. 300mm centres (fig.54)

### Step Nosing - Edge Boards

Pioneer edge boards can be used to create the perfect flush finish for steps (fig.55)

- Install the edge boards and decking step treads as per Steps 1-7 (p.20 parallel edge board installation)

### Step Nosing – Fascia Boards

For the step riser, attach fascia boards by screwing directly through into the step frame (p21)

- Ensure to pre-drill 4mm countersunk pilot holes and do not overdrive screw
- Install the first and second step tread boards as per Steps 1-6 (p15-17)

### Step Nosing - Corner Trims

Install corner nosing trim (p.22), when using Pioneer range deck boards for the riser (fig.56)

- Ensure to pre-drill 4mm countersunk pilot holes and do not overdrive screw

fig.54

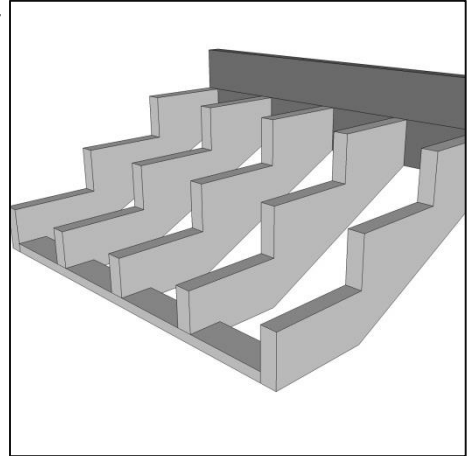

fig.55

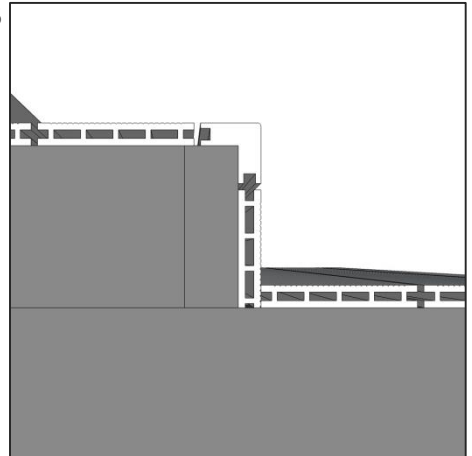
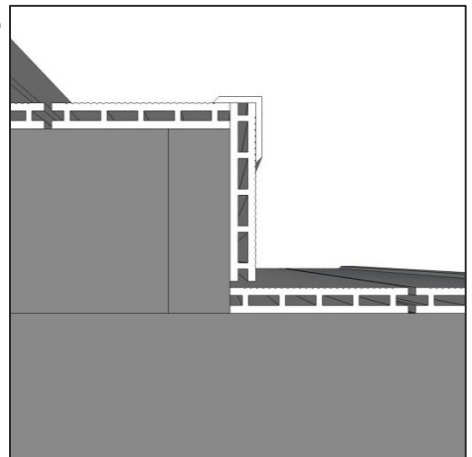

fig.56





## MAINTENANCE & CARE

Hyperion products are low maintenance, however with a little cleaning you can help keep your outside space looking beautiful for longer. Please note that although Hyperion products are relatively colour stable, there may be some initial lightening of the Pioneer range products as the product naturally weathers over the first 8-10 weeks.

With the proper safety precautions Hyperion products can be washed with either soapy water and a soft bristled brush or with a power washer (recommended max. 1500psi pressure). You should ensure to spray in the direction of the grain of the boards and use a fan tip nozzle (min. 6 inches from surface) along with an appropriate cleaning product.

### Dirt & Grime

Maintaining a clean, dry surface is the best method for combating dirt, grime and mildew build up, where a periodic cleaning is all that maybe required. Even though Hyperion products are formulated to inhibit mildew growth and staining, mildew stains can occur where moisture and dirt or pollen is present.

### Spot Stains

Many stains can be cleaned with soap or household degreasing agent and warm water. Scrub and soak the affected area as soon as the stain occurs to ensure best results, then rinse off with warm water. For more stubborn stains we recommend using a composite specific cleaner for more effective stain removal. Only with very set stains, you may want to use coarse sandpaper (60-80 grit) and sand lightly (Pioneer range products only), always in the direction of the grain of the product (be careful if sanding the flat wood grained side of the Pioneer decking board as this can remove the enhanced wood grain effect).

Cleaned or sanded areas may lighten, which can require 8-10 weeks exposure to the sun to match the remaining product, depending on location and specific application. Due to the wood content, composite products, like any wood-based product, may experience a naturally occurring process called Extractive Bleeding (known as tea staining). This process can cause a temporary discoloration that will fade with time.

### Scrapes & Scratches

Surface scratches and abrasions will fade after weathering. However, scrape and scratch marks can be eliminated by using a wire brush or coarse 60-80 grit sandpaper (Pioneer range products only). Simply brush/ sand in the direction of the grain on the product until the mark has gone. The treated area will weather back in approximately 8-10 weeks.

### Painting & Staining

EnviroBuild does not recommend that any treatments or stains should be applied to Hyperion products, however it is still possible for Hyperion products to be painted or stained. Wait until the product has completed its weathering process and ensure you have a clean and dry surface prior to applying any paint or stain. Always apply products in accordance with the manufacturer's application instructions.



**Q. Where can I use Hyperion Decking?**

A. The versatile Hyperion product range can be used in a variety of locations, both residential and commercial. Most common are external communal areas, balconies, pool sides as well as many more practical uses.

**Q. What colours do your products come in?**

A. Hyperion Decking comes in a variety of colours. For the Pioneer range we have the natural browns: Oak and Walnut, then the modern greys: Granite, Stone and Silver Birch. Our Frontier range consists of Slate, Marble, Iroko and Teak finishes.

**Q. Will the colour fade over time?**

A. Hyperion Pioneer products will naturally lighten over the first 8-12 weeks and then will stabilize after this period.

**Q. How slippery does the decking become when it gets wet?**

A. Hyperion Decking is designed with micro-grooves that aid in slip-resistance. Regardless of conditions, our ranges can outperform timber, however, we will recommend extra caution if the decking becomes wet.

**Q. How do your products react when exposed to water?**

A. Hyperion products are designed to take on very little water (c.1%). Our ranges have a much lower absorption rate than timber which heavily reduces the likelihood of wet rot over a longer period of time.

**Q. Do you have recommended installers I can use?**

A. EnviroBuild has an extensive network of recommended installers who we trust to bring your plans to reality. We have chosen these installers for their high quality of work and professionalism, but as with any third party, we recommend that you follow your own precautions before entering into a contract with them.

**Q. Does the decking require treating?**

A. Hyperion products are already coloured so do not require painting at all. Also, due to the plastic content within Hyperion products there is no need for any further treatment. This also makes it easy to clean.

**Q. Anything else?**

A. For any other technical, installation or care questions, go to [www.envirobuild.com](http://www.envirobuild.com), call our technical team on **0208 088 4888**, or email us at [info@envirobuild.com](mailto:info@envirobuild.com)

**Q. Can I see Hyperion Cladding samples?**

A. Simply go to [www.envirobuild.com](http://www.envirobuild.com) to order your samples.







ENVIRO  
BUILD

# **HYPERION**

D E C K I N G

ENVIROBUILD.COM



+44 (0) 208 088 4888

Version 3.6

©EnviroBuild 2018