

Technical Specification Sheet

ELBE CH II

ELBE CH II

dual lever mixer



REGINOX

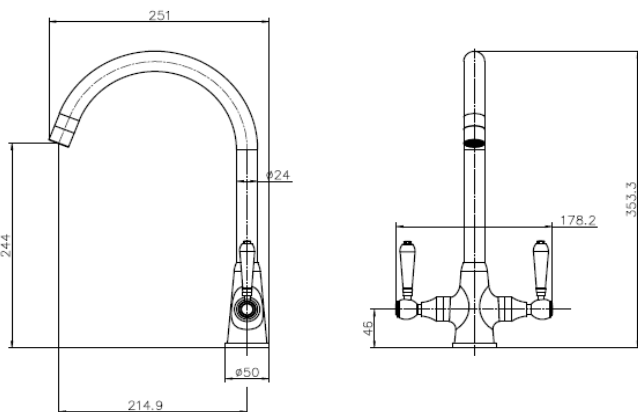

Specification

Finish	Polished Chrome
Body	Stainless Steel
Fitting	Deck Mounted
Connections	1/2" M10
Spout Rotation (°)	360

Dimensions

Tap Hole Size (mm)	35
Height (mm)	353.3
Base Width (mm)	50
Reach (mm)	214.9
Weight (kg)	1.1
Box Dimensions (mm)	400 X 240 X 65
Packed Weight (kg)	2

Bar Pressure

Minimum Pressure	0.5
Maximum Pressure	
Maximum Static Pressure	
Maximum Temperature (°C)	60

Flow Rates

@ 0.5 bar	@ 1 bar	@ 2 bar	@ 3 bar

Additional Features/Benefits

Dual lever with white ceramic bell levers

Aerator included

Suitable for low pressure

EAN

5060964934242

Warranty

10 Year Warranty (Casting Only)

Care & Maintenance

Reginox recommends cleaning your tap regularly with non-abrasive cleaners. Warm, soapy water would be best.

Certifications



All pressures are in bar.
 Dimensions supplied are nominal and subject to tolerance.
 Inclusion of aerator (if supplied) or restrictors (supplied separately) will affect flow rate result.
 Performance details are based on trials under test conditions and are for guidance only,
 The manufacturer reserves the right to change product specification without prior notice.