

PREMIUM SINK SPECIFICATIONS & INSTALLATION

PRODUCT
Sunstone Premium Drop-In Sink Combo w/Cover, Cutting Board, & Grid
Item No. B-PS21

DESCRIPTION
Sunstone Premium Style Commercial Quality Drop-In Sink Combo w/Cover, Cutting Board, Sink Grid, Hot/Cold Faucet, Soap Dispenser

PRODUCT DIMENSIONS
52,71cm WIDTH x 53,34cm DEPTH
30,48cm HEIGHT (PRODUCT SIZE)
46,36cm WIDTH x 46,99cm DEPTH
24,13cm HEIGHT (CUT-OUT)

SPECIFICATIONS
304 stainless steel for the sink. 18 gauge 304 for sink frame, Tap is made of brass with zinc plated. Dispenser is zinc-plated.



Av. Combatentes do Ultramar, 184
2715-776 Lameiras, Sintra
Portugal
TEL: (+351) 219 670 073
Email: info@sunstoneoutdoorkitchens.com

PRODUCT DIMENSIONS

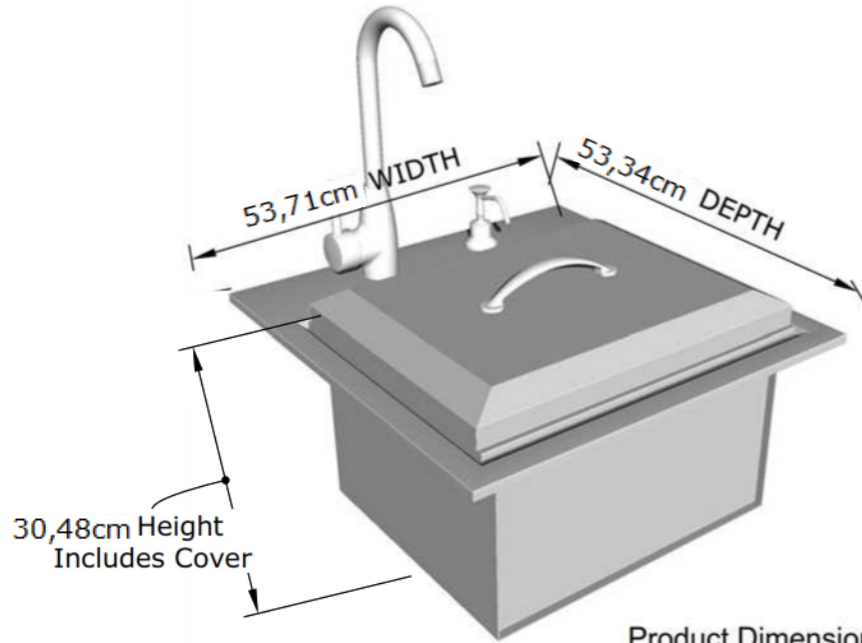

Product Dimensions are rounded to the nearest whole number.

CUT-OUT DIMENSIONS

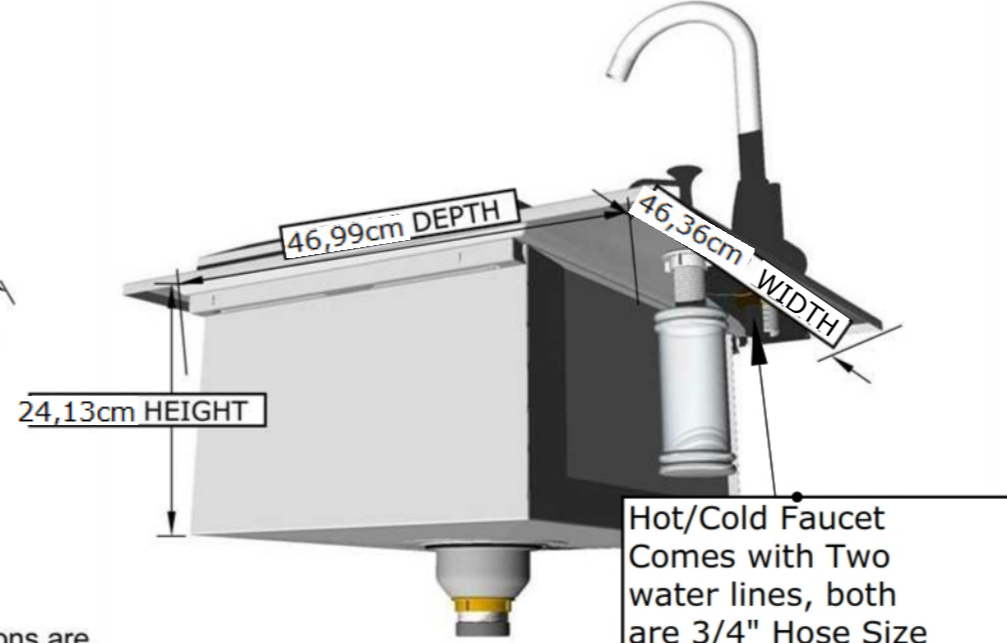

PARTS DIAGRAM

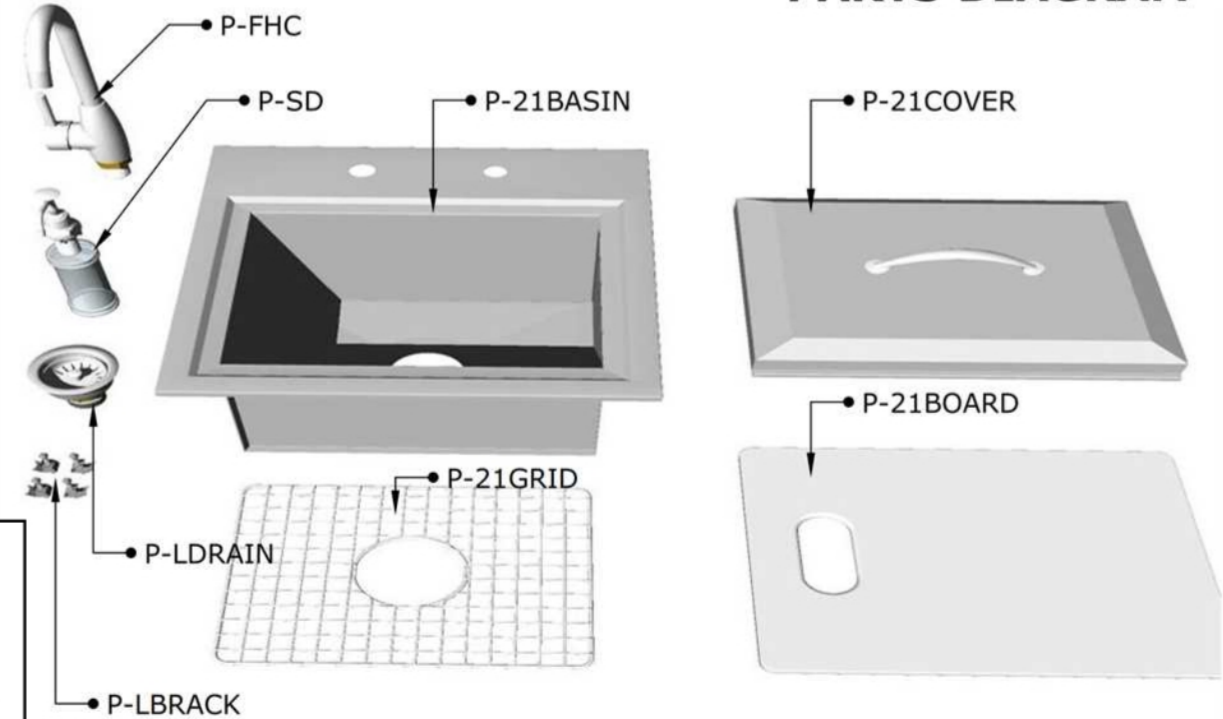

PLACING:

The Premium Sin is "Self-Rimming", meaning that whatever the Cut-Out edge looks like, as it is always rough, the product rim will cover all edges. Make the Cut-Out in counter surface matching to our provided dimensions shown, and simply insert Sink in through the open hole. It will Free-Hang so do not build any support below it, all other mounting brackets are included.

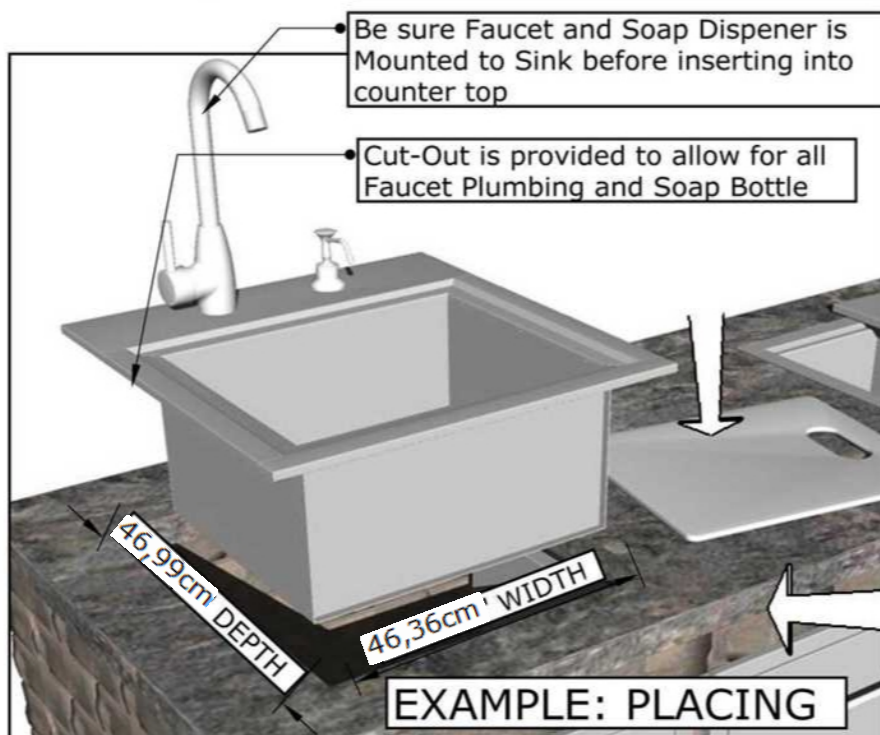

EXAMPLE: PLACING

MOUNTING:

For this step - you will need to locate the "Sliders" on the underside Left & Right Rim of the Sink. Locate the included Hardware inside the Sink Basin, push the Larger Head End into the larger Rounded Opening at each end of the Sliders and push it in then Slide it down until it reaches the Half Way Point. Use a Screw Driver to tighten the bracket in against the underside of the counter, you may need to grip it in other hand to gain stability.

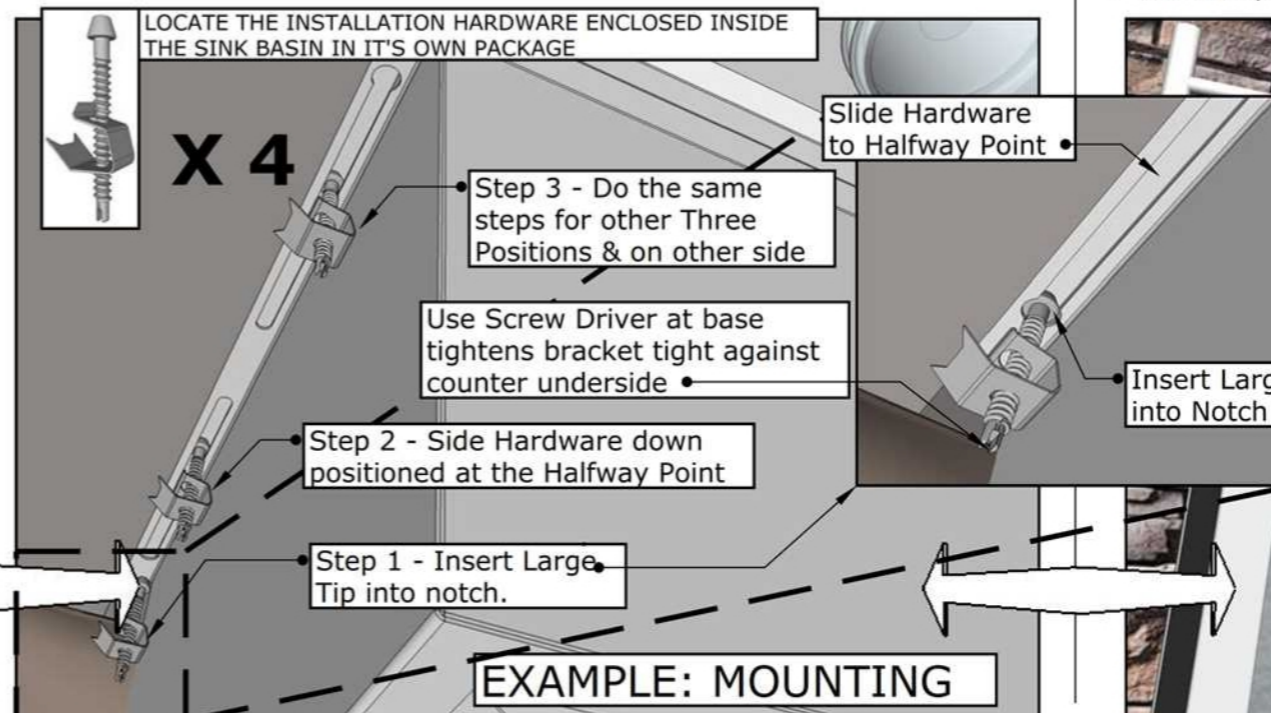

EXAMPLE: MOUNTING

ADJUSTING:

Access Doors should be installed below Sink for ease of access, this is also where you can install plumbing drain. The Sink Drain Width is 1-3/4" Inches Diameter and will fasten in to most drain assemblies. Depending on the Island Construction and or Local Building Code requirements, drains can be installed with complete P-Trap setup, or even using a simple Flex-Hose to side yard. Please check with own Local Building Codes and Permits required for Drain Lines.

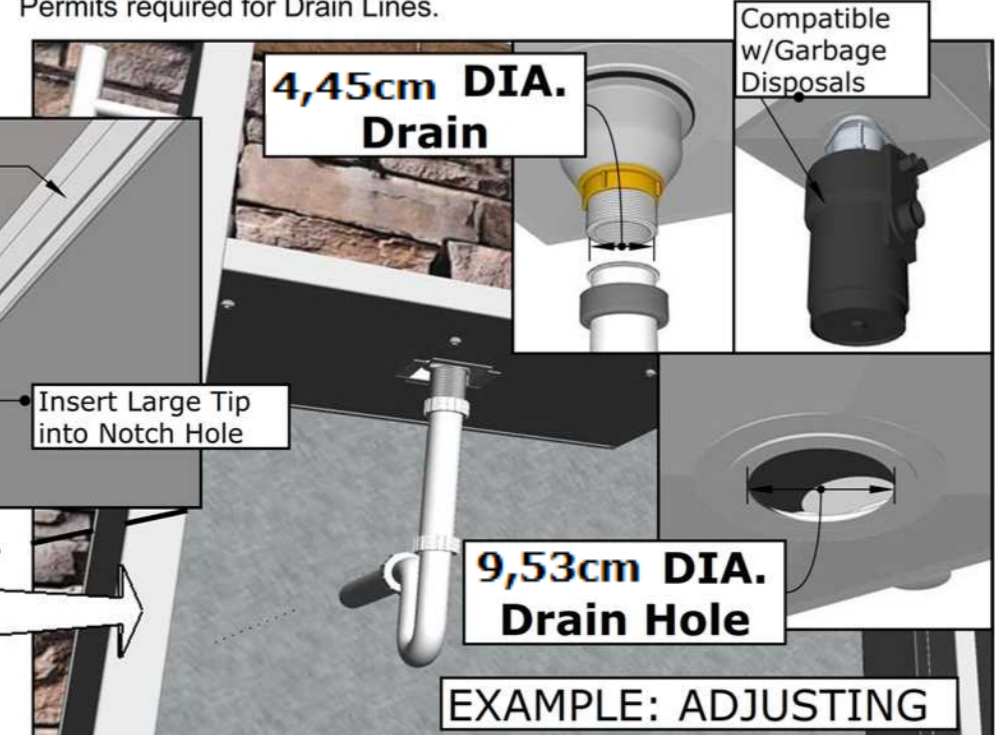

EXAMPLE: ADJUSTING

Sunstone Product Cut Sheet - Item No.B-PS21

Product Section Cut

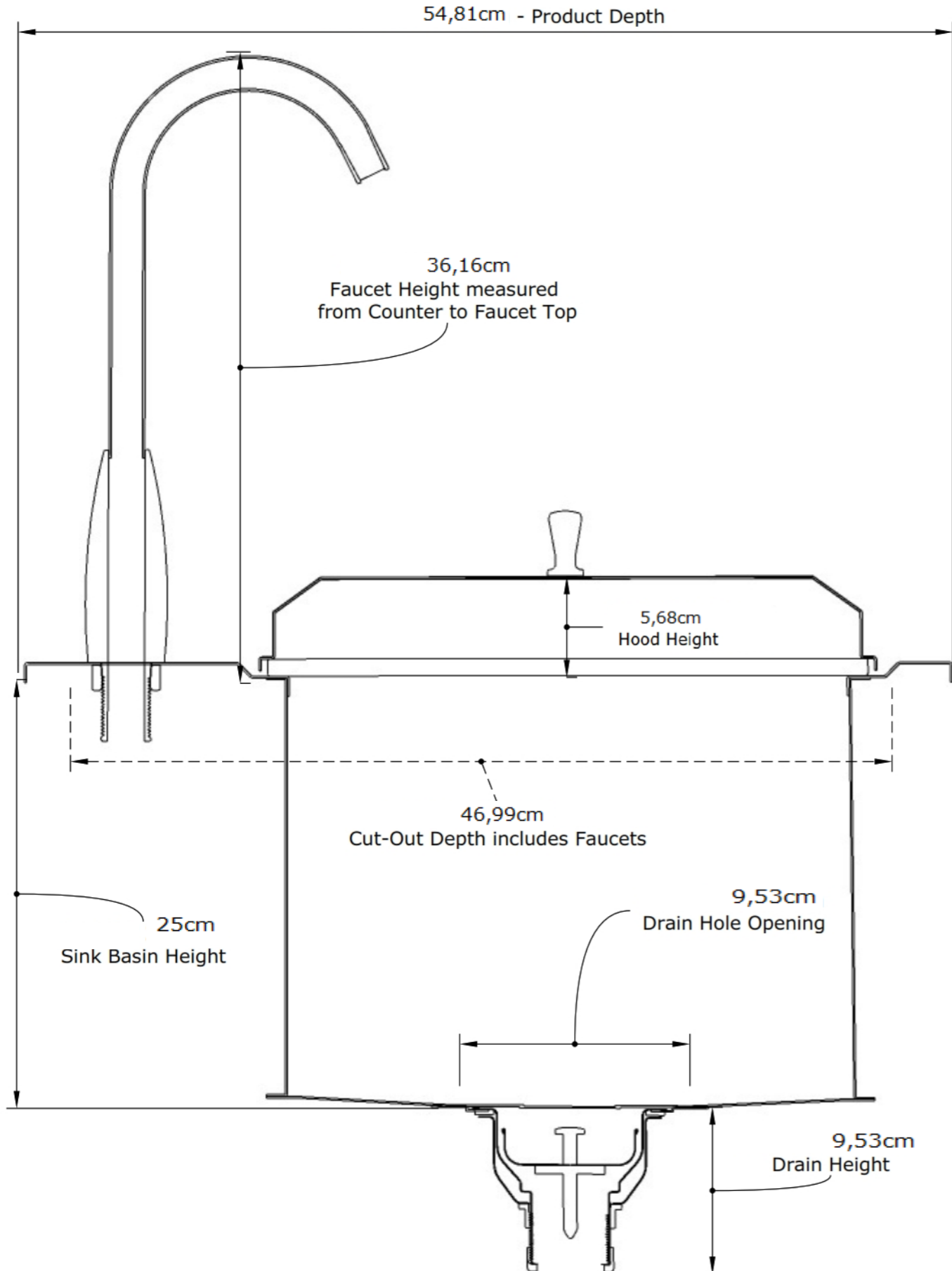

Product Line Drawing

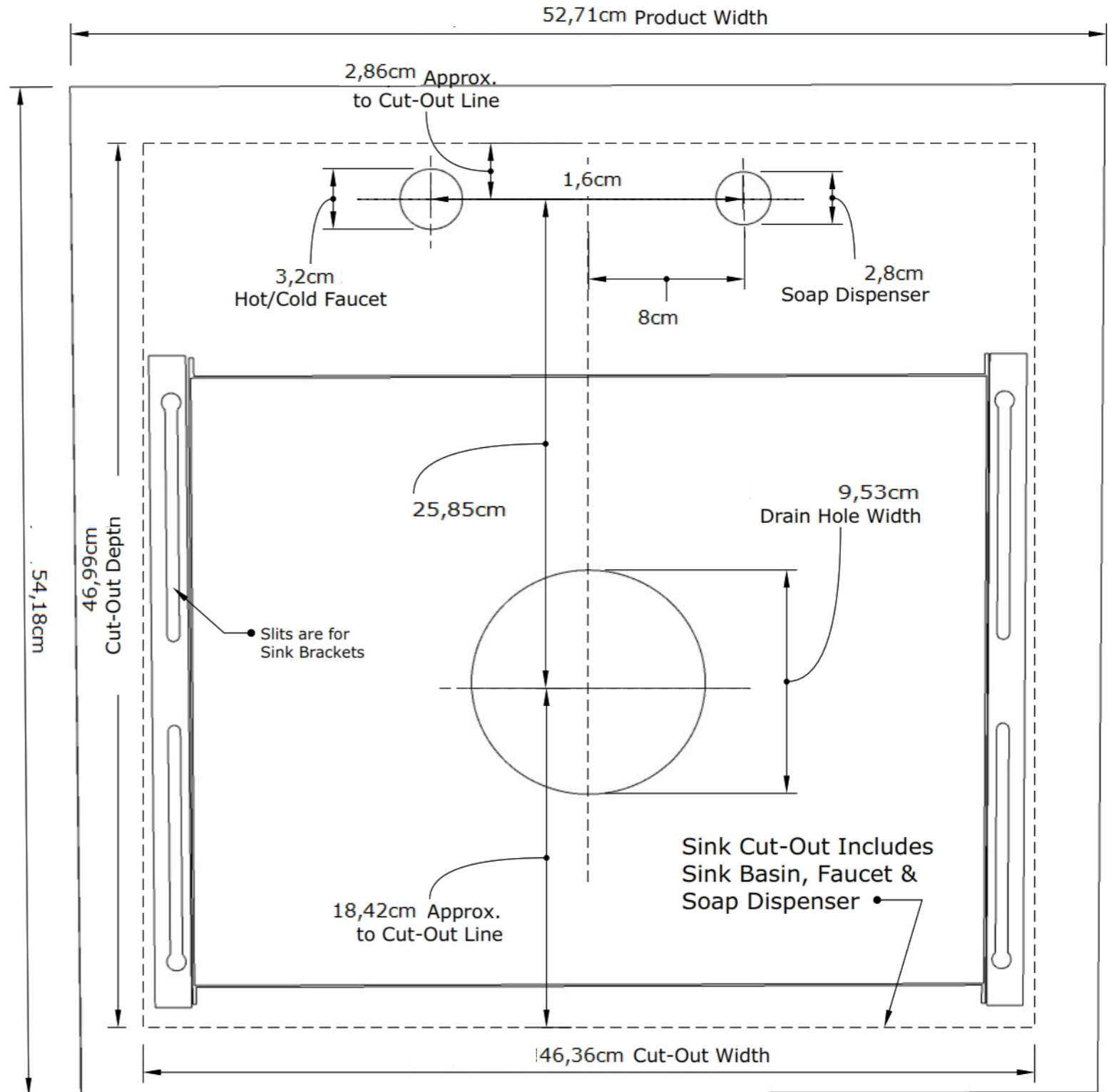

IMPORTANT!

Dimensions shown are Near Exact, based on engineered drawings actual product may be slightly different. Other dimensions shown on Specification sheet and Websites are rounded to the Nearest Whole Number to make it easier for our customers. If your still unsure, we recommend having the product on-site before the final Cut-Out is performed.