



DRAPER[®]

230V

TRIMMING ROUTER

58349



These instructions accompanying the product are the original instructions. This document is part of the product, keep it for the life of the product passing it on to any subsequent holder of the product. Read all these instructions before assembling, operating or maintaining this product.

This manual has been compiled by Draper Tools describing the purpose for which the product has been designed, and contains all the necessary information to ensure its correct and safe use. By following all the general safety instructions contained in this manual, it will ensure both product and operator safety, together with longer life of the product itself.

All photographs and drawings in this manual are supplied by Draper Tools to help illustrate the operation of the product.

Whilst every effort has been made to ensure the accuracy of information contained in this manual, the Draper Tools policy of continuous improvement determines the right to make modifications without prior warning.

1. TITLE PAGE

1.1 INTRODUCTION:

USER MANUAL FOR:230V Trimming Router

Stock No: 58349

Part No: PR710D

1.2 REVISIONS:

Date first published January 2019.

As our user manuals are continually updated, users should make sure that they use the very latest version.

Downloads are available from: <http://drapertools.com/manuals>

Draper Tools Limited

Hursley Road

Chandler's Ford

Eastleigh

Hampshire

SO53 1YF

UK

Website: drapertools.com

Product help line: +44 (0) 23 8049 4344

General Fax: +44 (0) 23 8026 0784

1.3 UNDERSTANDING THIS MANUALS SAFETY CONTENT:

WARNING! – Information that draws attention to the risk of injury or death.

CAUTION! – Information that draws attention to the risk of damage to the product or surroundings.

1.4 COPYRIGHT © NOTICE:

Copyright © Draper Tools Limited.

Permission is granted to reproduce this publication for personal and educational use only. Commercial copying, redistribution, hiring or lending is prohibited.

No part of this publication may be stored in a retrieval system or transmitted in any other form or means without written permission from Draper Tools Limited.

In all cases this copyright notice must remain intact.

2. CONTENTS

| | |
|--|-----------------|
| 1. TITLE PAGE | |
| 1.1 INTRODUCTION..... | 2 |
| 1.2 REVISION HISTORY | 2 |
| 1.3 UNDERSTANDING THIS MANUAL | 2 |
| 1.4 COPYRIGHT NOTICE | 2 |
| 2. CONTENTS | |
| 2.1 CONTENTS..... | 3 |
| 3. WARRANTY | |
| 3.1 WARRANTY..... | 4 |
| 4. INTRODUCTION | |
| 4.1 SCOPE..... | 5 |
| 4.2 SPECIFICATION | 5 |
| 4.3 HANDLING & STORAGE..... | 5 |
| 5. HEALTH AND SAFETY INFORMATION | |
| 5.1 GENERAL SAFETY INSTRUCTIONS FOR POWER TOOL USE | 6-7 |
| 5.2 SPECIFIC SAFETY INSTRUCTIONS FOR ROUTER USE..... | 7-8 |
| 5.3 RESIDUAL RISK..... | 8 |
| 5.4 CONNECTION TO THE POWER SUPPLY..... | 9 |
| 6. TECHNICAL DESCRIPTION | |
| 6.1 IDENTIFICATION | 10 |
| 7. UNPACKING AND CHECKING | |
| 7.1 PACKAGING | 11 |
| 7.2 WHAT'S IN THE BOX..... | 11 |
| 8. PREPARING THE ROUTER | |
| 8.1 INSTALLING AND REMOVING ROUTER BITS | 12 |
| 8.2 ADJUSTING BIT PROTRUSION | 12 |
| 8.3 ON OFF SWITCH..... | 13 |
| 8.4 CONSTANT SPEED CONTROL | 13 |
| 8.5 SOFT START | 13 |
| 8.6 VARIABLE SPEED | 13 |
| 9. BASIC ROUTER OPERATIONS | |
| 9.1 FOR THE TRIMMER BASE | 14 |
| 9.2 PARALLEL GUIDE | 15 |
| 9.3 CIRCULAR WORK..... | 16 |
| 9.4 TRIMMER GUIDE | 17 |
| 10. MAINTENANCE AND TROUBLESHOOTING | |
| 10.1 MAINTENANCE | 18 |
| 10.2 REPLACING CARBON BRUSHES..... | 18 |
| 10.3 TROUBLESHOOTING | 19 |
| 11. OPTIONAL ACCESSORIES | |
| 11.1 OPTIONAL ACCESSORIES..... | 20 |
| 12. DISPOSAL | |
| 12.1 DISPOSAL..... | 21 |
| 13. EXPLANATION OF SYMBOLS | |
| 13.1 EXPLANATION OF SYMBOLS | 22 |
| DECLARATION OF CONFORMITY | ENCLOSED |

3. WARRANTY

3.1 WARRANTY

Draper tools have been carefully tested and inspected before shipment and are guaranteed to be free from defective materials and workmanship.

Should the tool develop a fault, please return the complete tool to your nearest distributor or contact

Draper Tools Limited, Chandler's Ford, Eastleigh, Hampshire, SO53 1YF. England.

Telephone Sales Desk: (023) 8049 4333 or Product Help Line (023) 8049 4344.

A proof of purchase **must** be provided with the tool.

If upon inspection it is found that the fault occurring is due to defective materials or workmanship, repairs **will** be carried out free of charge. This warranty period covering labour is 12 months from the date of purchase except where tools are hired out when the warranty period is 90 days from the date of purchase. The warranty is extended to 24 months for parts only. This warranty does not apply to any consumable parts, any type of battery or normal wear and tear, nor does it cover any damage caused by misuse, careless or unsafe handling, alterations, accidents, or repairs attempted or made by any personnel other than the authorised Draper warranty repair agent.

Note: If the tool is found not to be within the terms of warranty, repairs and carriage charges will be quoted and made accordingly.

This warranty applies in lieu of any other warranty expressed or implied and variations of its terms are not authorised.

Your Draper warranty is not effective unless you can produce upon request a dated receipt or invoice to verify your proof of purchase within the warranty period.

Please note that this warranty is an additional benefit and does not affect your statutory rights.

Draper Tools Limited.

4. INTRODUCTION

4.1 SCOPE

This hand held power tool is ideal for shaping woodwork, cabinetry, architrave, morticing and other associated routing work.

As part of our core range, this product is suitable for enthusiasts and tradespeople alike. Any application other than that it was intended for, is considered misuse.

4.2 SPECIFICATION

| | |
|--------------------------------------|---|
| Stock No. | 58349 |
| Part No. | PR710D |
| Rated voltage | 230V~50Hz |
| Rated input | 710W |
| Collets | 6mm, 1/4" & 8mm |
| Plunge Stroke | 0-20mm |
| Speed (no load) | 13,000-33,000r/min |
| Sound pressure level (LpA)*: | 90.97dB(A) |
| Sound power level (LWA)**: | 101.97dB(A) |
| Uncertainty (K): | 3dB(A) |
| Vibration level Main handle†: | 3.090m/s ² , K=1.5m/s ² |
| Vibration level Extra handle†: | 2.757m/s ² , K=1.5m/s ² |
| Weight (machine only): | 2.16kg |

†When sawing in wood.

* Continuous A-Weighted Sound Pressure Level at the workstation in accordance to and declared according to EN60745.

** The typical A-weighted noise level determined according to EN60745

4.3 HANDLING & STORAGE

- Care must be taken when handling this product.
 - Dropping this power tool could have an effect on its accuracy and could also result in personal injury. This product is not a toy and must be respected.
- Environmental conditions can have a detrimental effect on this product if neglected.
 - Exposure to damp air can gradually corrode components.
 - If the product is unprotected from dust and debris, components will become clogged.
 - If not cleaned and maintained correctly or regularly, the machine will not perform at its best.

5. HEALTH AND SAFETY INFORMATION

5.1 GENERAL SAFETY INSTRUCTIONS FOR POWER TOOL USE

When using any type of power tool there are steps that should be taken to make sure that you, as the user, remain safe.

Common sense and a respect for the tool will help reduce the risk of injury.

Read the instruction manual fully. Do not attempt any operation until you have read and understood this manual.

Most important you must know how to safely start and stop this machine, especially in an emergency.

Keep the work area tidy and clean. Attempting to clear clutter from around the machine during use will reduce your concentration. Mess on the floor creates a trip hazard. Any liquid spilled on the floor could result in you slipping.

Find a suitable location. If the machine is bench mounted, the location should provide good natural light or artificial lighting as a replacement. Avoid damp and dust locations as it will have a negative effect on the machine's performance. If the machine is portable do not expose the tool to rain. In all cases do not operate power tools near any flammable materials.

Keep bystanders away. Children, onlookers and passers by must be restricted from entering the work area for their own protection. The barrier must extend a suitable distance from the tool user.

Unplug and house all power tools that are not in use. A power tool should never be left unattended while connected to the power supply. They must be housed in a suitable location, away locked up and from children. This includes battery chargers.

Do not overload or misuse the tool. All tools are designed for a purpose and are limited to what they are capable of doing. Do not attempt to use a power tool (or adapt it in any way) for an application it is not designed for. Select a tool appropriate for the size of the job. Overloading a tool will result in tool failure and user injury. This covers the use of accessories.

Dress properly. Loose clothing, long hair and jewellery are all dangerous because they can become entangled in moving machinery. This can also result in parts of body being pulled into the machine. Clothing should be close fitted, with any long hair tied back and jewellery and neck ties removed. Footwear must be fully enclosed and have a non-slip sole.

Wear personal protective equipment (PPE). Dust, noise, vibration and swarf can all be dangerous if not suitably protected against. If the work involving the power tool creates dust or fumes wear a dust mask. Vibration to the hand, caused by operating some tools for longer periods must be protected against. Wear vibration reducing gloves and allow long breaks between uses. Protect against dust and swarf by wearing approved safety goggles or a face shield. These are some of the more common hazards and preventions, however, always find out what hazards are associated with the machine/work process and wear the most suitable protective equipment available.

Do not breathe contaminated air. If the work creates dust or fumes connect the machine (if possible) to an extraction system either locally or remotely. Working outdoors can also help if possible.

Move the machine as instructed. If the machine is hand held, do not carry it by the power supply cable. If the product is heavy, employ a second or third person to help move it safely or use a mechanical device. Always refer to the instructions for the correct method.

Do not overreach. Extending your body too far can result in a loss of balance and you falling. This could be from a height or onto a machine and will result in injury.

Maintain your tools correctly. A well maintained tool will do the job safely. Replace any damaged or missing parts immediately with original parts from the manufacturer. As applicable, keep blades sharp, moving parts clean, oiled or greased, handles clean, and emergency devices working.

5. HEALTH AND SAFETY INFORMATION

Wait for the machine to stop. Unless the machine is fitted with a safety brake, some parts may continue to move due to momentum. Wait for all parts to stop, then unplug it from the power supply before making any adjustments, carrying out maintenance operations or just finishing using the tool.

Remove and check setting tools. Some machinery requires the use of additional tools or keys to set, load or adjust the power tool. Before starting the power tool always check to make certain they have been removed and are safely away from the machine.

Prevent unintentional starting. Before plugging any machine in to the power supply, make sure the switch is in the OFF position. If the machine is portable, do not hold the machine near the switch and take care when putting the machine down, that nothing can operate the switch.

Carefully select an extension lead. Some machines are not suitable for use with extension leads. If the tool is designed for use outdoors, use an extension lead also suitable for that environment. When using an extended lead, select one capable of handling the current (amps) drawn by the machine in use. Fully extend the lead regardless of the distance between the power supply and the tool. Excess current (amps) and a coiled extension lead will both cause the cable to heat up and can result in fire.

Concentrate and stay alert. Distractions are likely to cause an accident. Never operate a power tool if you are under the influence of drugs (prescription or otherwise), including alcohol or if you are feeling tired. Being disorientated will result in an accident.

Have this tool repaired by a qualified person. This tool is designed to conform to the relevant international and local standards and as such should be maintained and repaired by someone qualified, using only original parts supplied by the manufacturer. This will ensure the tool remains safe to use.

5.2 SPECIFIC SAFETY INSTRUCTIONS FOR ROUTER USE

- Hold power tool by insulated gripping surfaces, when performing an operation where the cutting accessory may contact hidden wiring or its own cord. Cutting accessory contacting a "live" wire may make exposed metal parts of the power tool "live" and could give the operator an electric shock.
- Always wear a dust mask and ear protection when using this power tool.
- Use only bits, which are designed for this router.
- Use only sharp bits that are not chipped or cracked. Blunt bits will cause stalling.
- Secure small pieces of wood firmly before working. Never hold them in your hand.
- Danger. Keep hands away from the cutting area.
- Secure the workpiece by means of the clamping equipment.
- Before starting up, check that the bit is firmly positioned and secured into the collets.
- The maximum indicated limit rotation speed of the milling bit must not be exceeded.
- Routing must always be carried out against the direction of rotation (bit-rotation) of the bit.
- The bit must be running at full speed before lowering into the workpiece.
- When operating the machine, take great care and always hold the router handles firmly with both hands. Always provide for a secure footing when working.
- Beware of the reaction torque of the machine, particularly if the bit becomes jammed in the workpiece.
- On completion of work, allow the machine to slide back to its initial position by releasing the handle.
- Make yourself familiar with your working area and be alert for possible hazards, which you might not hear due to machine noise.
- Never use cutters whose shank does not match the collet e.g. never use a 6mm shank cutter in a 1/4" collet.

5. HEALTH AND SAFETY INFORMATION

- Caution: Allow for run down time of bit after turning router off. Wait for the machine to come to a complete stop before removing from the workpiece.
- Never slow the router down with your hands.
- Do not touch the bit immediately after operation; it may be extremely hot and could burn you.
- Never stop the router by applying lateral pressure to the bit.
- Do not force the router. Your router will do a better job if you take it slowly.
- Avoid cutting nails and screws. Inspect timber and remove all nails and screws before cutting.
- In the event of an electrical or mechanical malfunction, immediately switch off the router and disconnect the power lead from the mains supply, and contact Draper for assistance.

5.3 RESIDUAL RISK

Important note: Although the safety instructions and operating manuals for our tools contain extensive instructions for safe working with power tools, every power tool involves a certain residual risk which can not be completely excluded by safety mechanisms. Power tools must therefore always be operated with caution!

5. HEALTH AND SAFETY INFORMATION

5.4 CONNECTION TO THE POWER SUPPLY

Caution: Risk of electric shock. Do not open.

This appliance is supplied with a moulded 3 pin mains plug for your safety. The value of the fuse fitted is marked on the pin face of the plug. Should the fuse need replacing, ensure the substitute is of the correct rating, approved to BS1362 and ASTA or BSI Kite marked.

ASTA 

BSI 

The fuse cover is removable with a small plain slot screwdriver. Ensure the fuse cover is replaced before attempting to connect the plug to an electrical outlet. If the cover is missing, a replacement must be obtained or the plug replaced with a suitable type.

If a replacement plug is to be fitted this must be carried out by a qualified electrician.

The damaged or incomplete plug, when cut from the cable should be disabled to prevent connection to a live electrical outlet.

This appliance is Class II[†] and is designed for connection to a power supply matching that detailed on the rating label and compatible with the plug fitted.

If an extension lead is required, use an approved and compatible lead rated for this appliance. Follow all the instructions supplied with the extension lead.

[†]Double insulated : This product requires no earth connection as supplementary insulation is applied to the basic insulation to protect against electric shock in the event of failure of the basic insulation.

IMPORTANT

If using an extension lead, follow the instructions that came with your lead regarding maximum load while cable is wound. If in doubt, ensure that the entire cable is unwound. Using a coiled extension lead will generate heat which could melt the lead and cause a fire.

6. TECHNICAL DESCRIPTION

6.1 IDENTIFICATION

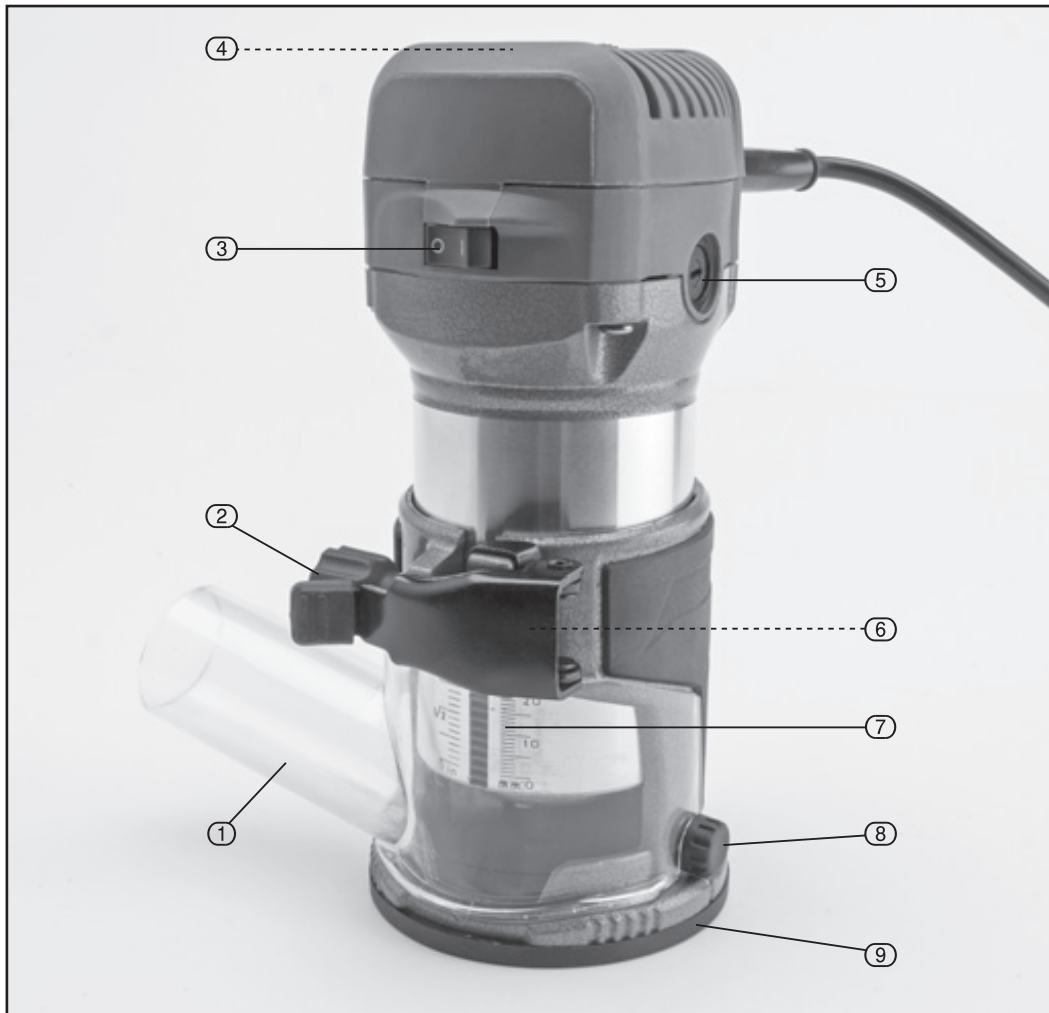

- ① Dust extraction outlet.
- ② Locking lever.
- ③ On/Off switch.
- ④ Variable speed.
- ⑤ Brush holder cap.
- ⑥ Spindle lock
- ⑦ Depth scale.
- ⑧ Thumb screw.
- ⑨ Trimmer base.

7. UNPACKING AND CHECKING

7.1 PACKAGING

Carefully remove the product from the packaging and examine it for any sign of damage that may have happened during shipping. Lay the contents out and check them against the parts shown below. If any part is damaged or missing, please contact the Draper Help Line (the telephone number appears on the Title page) and do not attempt to use the product.

The packaging material should be retained at least during the guarantee period: in case the machine needs to be returned for repair.

Warning!

- Some of the packaging materials used may be harmful to children. Do not leave any of these materials in the reach of children.
- If any of the packaging is to be thrown away, make sure they are disposed of correctly, according to local regulations.

7.2 WHAT'S IN THE BOX

As well as the main product, there are also several other parts not fitted or attached to it:

- (10) 3x collets.
- (11) Straight guide.
- (12) Guide plate.
- (13) Spanner.
- (14) Trimming guide.

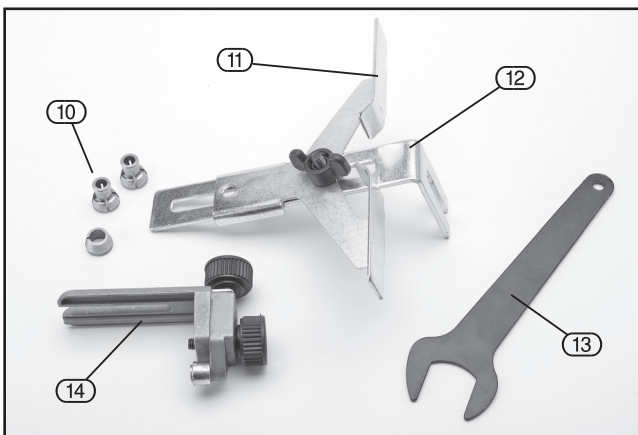

8. PREPARING THE ROUTER

Caution: Always be sure that the tool is switched off and unplugged before adjusting or checking function on the tool.

8.1 INSTALLING AND REMOVING ROUTER BITS

Remove router trimmer from trimmer base.

Depress spindle locking button (6) so it engages with the hole in the spindle. With the locking button depressed, unscrew the hex nut with the provided spanner (13).

Insert the appropriate collet (10) for the shank of the router bit to be used.

Note: It is important that the router bit shank fits snug into the collet.

6mm, 1/4" (6.35mm) and 8mm collets are supplied.

Feed the router bit shank through the hex and screw hex nut onto spindle thread to hand tight.

Depress spindle lock button to engage with spindle and fully tighten hex nut using spanner.

Replace outer trimmer back into trimmer base.

8.2 ADJUSTING CUTTING DEPTH

To adjust the cutting depth, loosen the locking lever and move the tool base up or down as desired by turning the adjusting screw. After adjusting, tighten the locking lever firmly to secure the tool base.



FIG.1

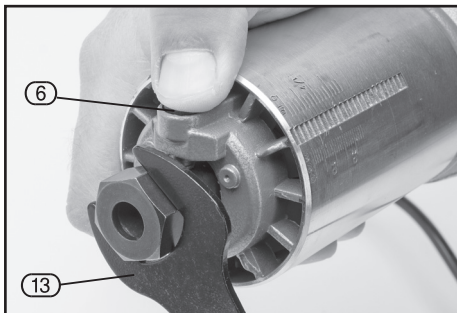

FIG.2

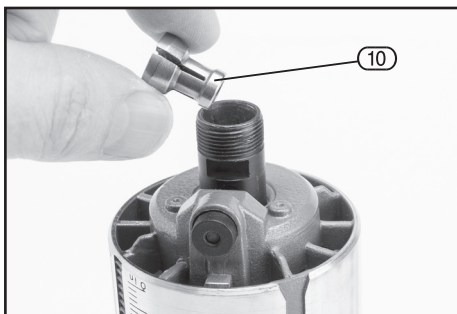

FIG.3

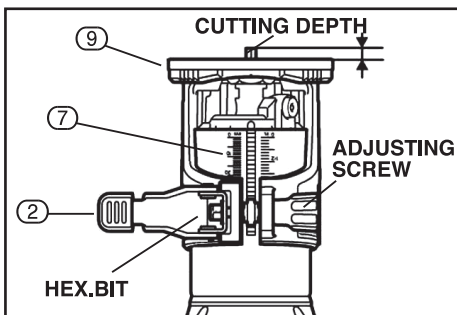

FIG.4

8. PREPARING THE ROUTER

8.3 ON OFF SWITCH

To start the tool, press the “ON (I)” side of the switch. To stop the tool, press the “OFF (O)” side of the switch.

8.4 CONSTANT SPEED CONTROL

This router trimmer features constant speed control. This function ensures rotating speed is kept constant even under load resulting in consistent fine finish.

8.5 SOFT START

Soft-start feature minimizes start-up shock.

8.6 VARIABLE SPEED

The tool speed can be changed by turning the speed adjusting dial to a given number setting from 1 to 6. Higher speed is obtained when the dial is turned in the direction of number 6. And lower speed is obtained when it is turned in the direction of number 1.

This allows the ideal speed to be selected for optimum material processing, i.e. the speed can be correctly adjusted to suit the material and bit diameter.

Refer to the table for the relationship between the number settings on the dial and the approximate tool speed.

Caution: If the tool is operated continuously at low speeds for a long time, the motor will get overloaded, resulting in tool malfunction.

The speed adjusting dial can be turned only as far as 6 and back to 1. Do not force it past 6 or 1, or the speed adjusting function may no longer work.

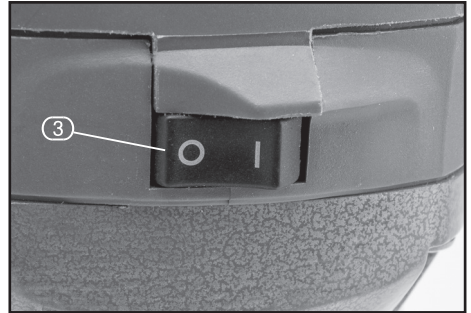

FIG.5



FIG.6

| Setting | Approx. speed (r/min) |
|---------|-----------------------|
| 1 | 10,000 |
| 2 | 12,000 |
| 3 | 17,000 |
| 4 | 22,000 |
| 5 | 27,000 |
| 6 | 30,000 |

9. BASIC ROUTER OPERATIONS

9.1 FOR THE TRIMMER BASE

Warning: Before using the tool with the trimmer base, always install the dust nozzle on the trimmer base.

Set the tool base on the workpiece to be cut without the bit making any contact. Then turn the tool on and wait until the bit attains full speed. Move the tool forward over the workpiece surface, keeping the tool base flush and advancing smoothly until the cutting is complete. When doing edge cutting, the workpiece surface should be on the left side of the bit in the feed direction.

Caution: Since excessive cutting may cause overload of the motor or difficulty in controlling the tool, the depth of cut should not be more than 3 mm (1/8") at a pass when cutting grooves. When you wish to cut grooves more than 3 mm (1/8") deep, make several passes with progressively deeper bit settings.

Note: Moving the tool forward too fast may cause a poor quality of cut, or damage to the bit or motor. Moving the tool forward too slowly may burn and mar the cut. The proper feed rate will depend on the bit size, the kind of workpiece and depth of cut. Before beginning the cut on the actual workpiece, it is advisable to make a sample cut on a piece of scrap lumber. This will show exactly how the cut will look as well as enable you to check dimensions.

When using the trimmer shoe, the straight guide or the trimmer guide, be sure to keep it on the right side in the feed direction. This will help to keep it flush with the side of the workpiece.



FIG. 7

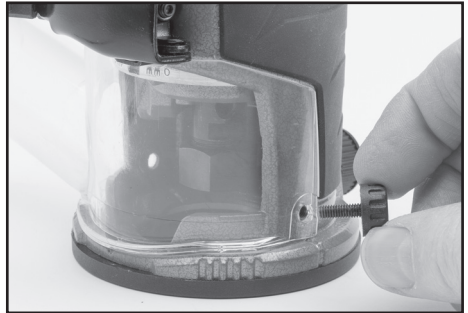

FIG. 8

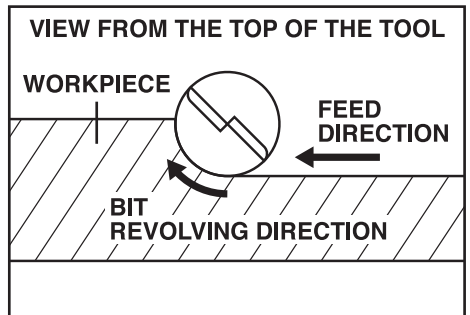

FIG. 9

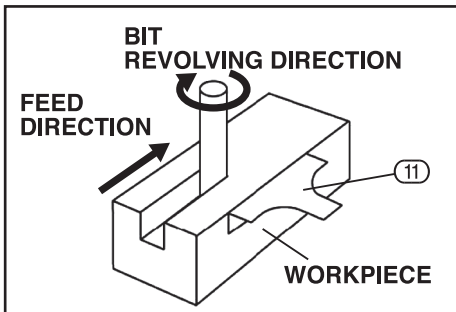

FIG. 11

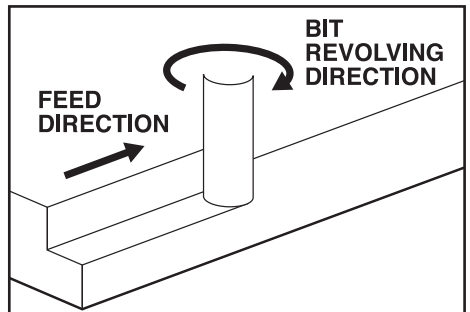

FIG. 10

9. BASIC ROUTER OPERATIONS

9.2 PARALLEL GUIDE

The straight guide is effectively used for straight cuts when chamfering or making grooves.

Attach the guide plate (12) to the straight guide (11) with the bolt and the wing nut.

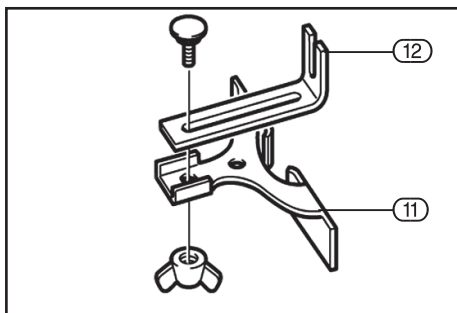

FIG.12

Attach the straight guide with the thumb screw (8). Loosen the wing nut on the straight guide and adjust the distance between the bit and the straight guide. At the desired distance, tighten the wing nut securely.

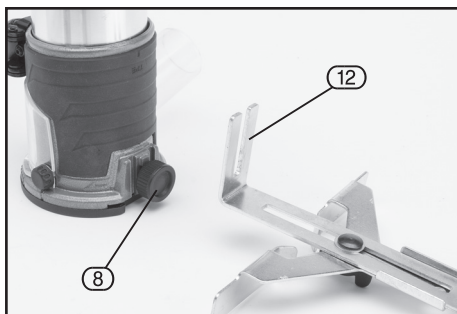

FIG.13



FIG.14

When cutting, move the tool with the straight guide flush with the side of the workpiece.

If the distance between the side of the workpiece and the cutting position is too wide for the straight guide, or if the side of the workpiece is not straight, the straight guide cannot be used. In this case, firmly clamp a straight board to the workpiece and use it as a guide against the trimmer base. Feed the tool in the direction of the arrow.

9. BASIC ROUTER OPERATIONS

9.3 CIRCULAR WORK

Circular work may be accomplished if you assemble the straight guide and guide plate as shown in the figures. Min. and max. radius of circles to be cut (distance between the center of circle and the center of bit) are as follows:

Min.: 70 mm (2-3/4")

Max.: 221 mm (8-11/16")

For cutting circles between 70 mm (2-3/4") and 121 mm (4-3/4") in radius.

For cutting circles between 121 mm (4-3/4") and 221 mm (8-11/16") in radius.

Note: Circles between 172 mm (6-3/4") and 186mm. (7-5/16") in radius cannot be cut using this guide. Align the center hole in the straight guide with the center of the circle to be cut. Drive a nail less than 6 mm (1/4") in diameter into the center hole to secure the straight guide. Pivot the tool around the nail in clockwise direction.

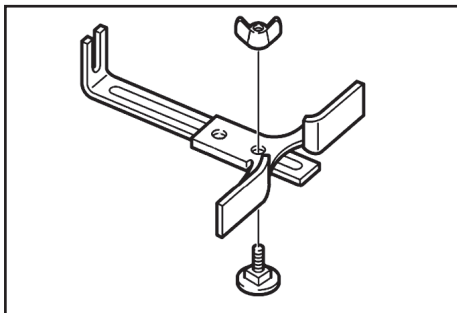

FIG. 15

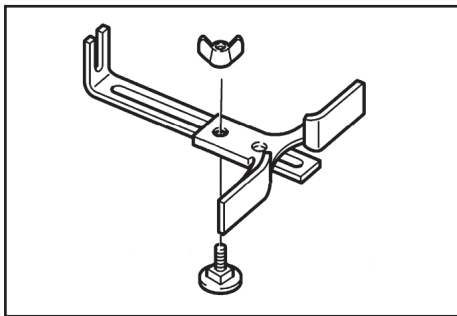

FIG. 16

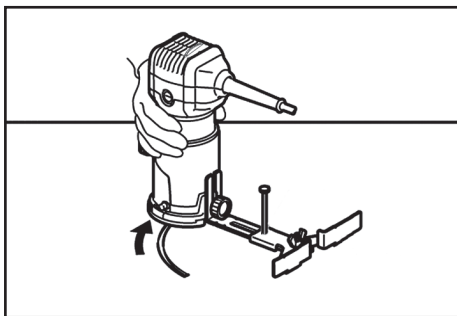

FIG. 17

9. BASIC ROUTER OPERATIONS

9.4 TRIMMER GUIDE

Trimming, curved cuts in veneers for furniture and the like can be done easily with the trimming guide (14). The guide roller rides the curve and assures a fine cut. Install the trimming guide on the tool base with the thumb screw (8). Loosen the thumb screw (8) and adjust the distance between the bit and the trimmer guide by turning the adjusting screw (8.1) (1 mm (3/64") per turn). At the desired distance, tighten the thumb screw (8) to secure the trimming guide in place.

When cutting, move the tool with the guide roller riding the side of the workpiece.

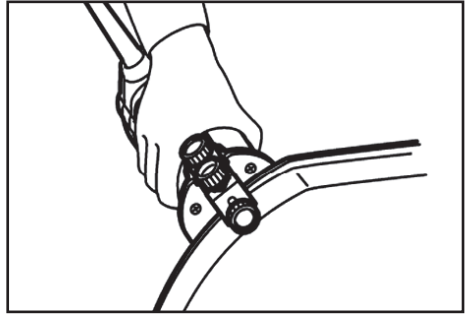

FIG.18

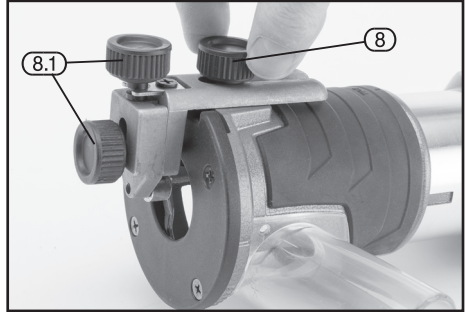

FIG.19

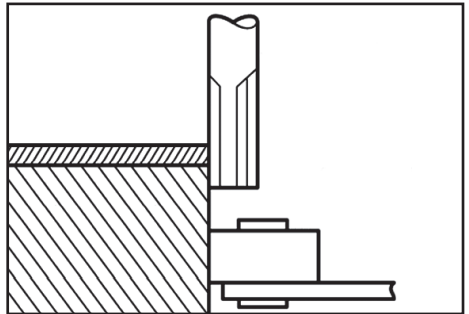

FIG.20

10. MAINTENANCE AND TROUBLESHOOTING

10.1 MAINTENANCE

Regular inspection and cleaning reduces the necessity for maintenance operations and will keep your tool in good working condition.

The motor must be correctly ventilated during tool operation. Avoid blocking the air inlets and vacuum the ventilation slots regularly.

10.2 REPLACING CARBON BRUSHES

Remove and check the carbon brushes regularly. Replace when they wear down to the limit mark. Keep the carbon brushes clean and free to slip in the holders. Both carbon brushes should be replaced at the same time. Use only identical carbon brushes.

Use a screwdriver to remove the brush holder caps. Take out the worn carbon brushes, insert the new ones and secure the brush holder caps.

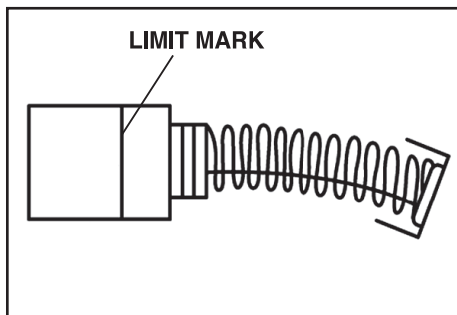

FIG.21

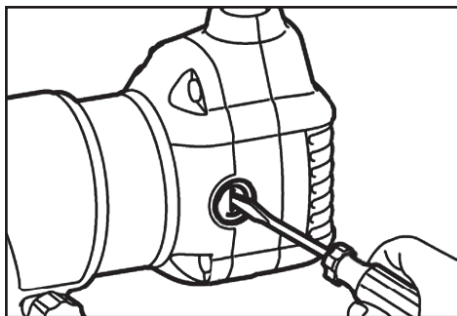

FIG.22

10. MAINTENANCE AND TROUBLESHOOTING

10.3 TROUBLESHOOTING

Note: Remove the plug from the socket before carrying out adjustment, servicing or maintenance.

| Problem | Cause | Remedy |
|-------------------------|--|---|
| Machine does not start. | <ol style="list-style-type: none">1. Blown fuse.2. Brushes worn.3. Other. | <ol style="list-style-type: none">1. Replace time delay fuse or reset circuit breaker.2. Have brushes replaced by an authorised service centre.3. Contact an authorised service centre. |
| Machine vibrates. | <ol style="list-style-type: none">1. Router bit not suitable for application.2. Router bit blunt.3. Incorrect direction of travel. | <ol style="list-style-type: none">1. Seek guidance on bit selection.2. Stop machine. When stopped, replace with a sharp bit.3. Change direction of travel. |
| Bit will not cut. | <ol style="list-style-type: none">1. Attempting to remove excess material.2. Router bit blunt3. Incorrect direction of travel | <ol style="list-style-type: none">1. Reduce plunge depth.2. Stop machine. When stopped, replace with a sharp bit3. Change direction of travel |

11. OPTIONAL ACCESSORIES

11.1 OPTIONAL ACCESSORIES

A full range of accessories are available from Draper Tools.

Please visit our website for details: www.drapertools.com

12. DISPOSAL

12.1 DISPOSAL

- At the end of the machine's working life, or when it can no longer be repaired, ensure that it is disposed of according to national regulations.
- Contact your local authority for details of collection schemes in your area.

In all circumstances:

- Do not dispose of power tools with domestic waste.
- Do not incinerate.
- Do not dispose of WEEE* as unsorted municipal waste.



* *Waste Electrical & Electronic Equipment.*

13. EXPLANATION OF SYMBOLS

13.1 EXPLANATION OF SYMBOLS



Read the instruction manual.



Wear face mask and safety glasses.



Wear ear defenders.



Wear protective gloves.



Do not abandon into the environment.



Keep out of the reach of children.



Warning!



Single value noise marking.
(Maximum declared A-Weighted sound power level in decibels).



Class II construction
(Double insulated).



WEEE –
Waste Electrical & Electronic Equipment.
Do not dispose of Waste Electrical & Electronic Equipment in with domestic rubbish.



Lithium-ion product.

Li-ion



Do not incinerate or throw onto fire.



For indoor use only.
Do not expose to rain.



Short-circuit-proof safety isolating transformer.

F



Fuse.



Polarity indication.



Rated voltage.

NOTES

CONTACTS

Draper Tools Limited, Hursley Road,
Chandler's Ford, Eastleigh, Hampshire. SO53 1YF. U.K.

Help line: (023) 8049 4344

Sales Desk: (023) 8049 4333

Internet: drapertools.com

E-mail: sales@drapertools.com

General Enquiries: (023) 8026 6355

Service/Warranty Repair Agent:

For aftersales servicing or warranty repairs, please contact the Draper Tools Help line for details of an agent in your local area.

YOUR DRAPER STOCKIST

TAKC0119

©Published by Draper Tools Limited.

No part of this publication may be reproduced, stored in a retrieval system or transmitted in any form or by any means, electronic, mechanical photocopying, recording or otherwise without prior permission in writing from Draper Tools Ltd.