

DRAPER®

INSTRUCTIONS FOR HVLP Air Spray Gun

Stock No. 09708	Part No.	GSG5-100
09706		GSG5-600
09709		GSG5-COMP-100
09707		GSG5-COMP-600

IMPORTANT: PLEASE READ THESE INSTRUCTIONS CAREFULLY TO ENSURE THE SAFE AND EFFECTIVE USE OF THIS PRODUCT.



CE

DRAPER®

GENERAL INFORMATION

These instructions accompanying the product are the original instructions. This document is part of the product, keep it for the life of the product passing it on to any subsequent holder of the product. Read all these instructions before assembling, operating or maintaining this product.

This manual has been compiled by Draper Tools describing the purpose for which the product has been designed, and contains all the necessary information to ensure its correct and safe use. By following all the general safety instructions contained in this manual, it will ensure both product and operator safety, together with longer life of the product itself. All photographs and drawings in this manual are supplied by Draper Tools to help illustrate the operation of the product. Whilst every effort has been made to ensure the accuracy of information contained in this manual, the Draper Tools policy of continuous improvement determines the right to make modifications without prior warning.



CONTENTS

- 1. Guarantee 1
- 2. Specification & scope 2
- 3. Air supply 3
- 4. Safety instructions 4
- 5. Typical material flow rate 5
- 6. Identification guide 6
- 7. Assembly
 - Attaching an air line coupling 7
 - Connecting the paint pot 7
- 8. Operation & Use
 - Spray gun setup - Spray pattern control 8
 - Spray gun setup - Air control 8
 - Spray gun setup - Paint control 8
 - Spray gun setup - Test Pattern 9
 - Spraying technique 10
- 9. Maintenance 10
- 10. Troubleshooting 10 - 11
- 11. Disposal 12
- Declaration of conformity Enclosed



1. GUARANTEE

Draper air tools have been carefully tested and inspected before shipment and are guaranteed to be free from defective materials and workmanship for 6 months from the date of purchase except where tools are hired out when the guarantee period is ninety days from the date of purchase.

Should the machine develop any fault, please return the complete tool to your nearest authorised warranty repair agent or contact Draper Tools Limited, Chandler's Ford, Eastleigh, Hampshire, SO53 1YF England. Telephone Sales Desk: (023) 8049 4333 or Product Helpline (023) 8049 4344.

A proof of purchase must be provided with the tool.

If, upon inspection it is found that the fault occurring is due to defective materials or workmanship, repairs will be carried out free of charge. This guarantee does not apply to normal wear and tear, nor does it cover any damage caused by misuse, careless or unsafe handling, alterations, accident, or repairs attempted or made by any persons other than the authorised Draper warranty repair agent.

Note: If the tool is found not to be within the terms of warranty, repairs and carriage charges will be quoted and made accordingly.

This guarantee applies in lieu of any other guarantee expressed or implied and variation of its terms are not authorised.

Your Draper guarantee is not effective unless you can produce upon request a dated receipt or invoice to verify your proof of purchase within the guarantee period.

Please note that this guarantee is an additional benefit and does not affect your statutory rights.

2. SPECIFICATION

The Draper Tools policy of continuous improvement determines the right to change specification without notice.

Stock no.	09708.....	09706.....	09709.....	09707.....
Part no.	GSG5-100.....	GSG5-600.....	GSG5-COMP-100.....	GSG5-COMP-600.....
Operating air pressure.....	1.4-2.0bar(20-30psi)	2.0-3.0bar(30-43psi)	1.4-2.0bar(20-30psi)	2.0-3.0bar(30-43psi)
Maximum air pressure.....	2.0bar(30psi)	3.0bar(43psi)	2.0bar(30psi)	3.0bar(43psi)
Average air consumption.....	226l/min(8.0cfm)	400l/min(14.5cfm)	226l/min(8.0cfm)	400l/min(14.5cfm)
Air inlet.....	¼" BSP	¼" BSP	¼" BSP	¼" BSP
Air cap size.....	1.0mm	1.4mm	1.0mm	1.4mm
Paint pot capacity.....	100ml	600ml	100ml	600ml
Sound pressure level†.....	74.8dB(A)	74.8dB(A)	74.8dB(A)	74.8dB(A)
Sound power level†.....	N/A	N/A	N/A	N/A
Vibration level†.....	<2.5m/s ²	<2.5m/s ²	<2.5m/s ²	<2.5m/s ²
Nett weight.....	340g	736g	248g	558g

ALWAYS WEAR APPROVED PERSONAL PROTECTIVE EQUIPMENT SUITABLE FOR USE IN A PAINT SPRAYING ENVIRONMENT.

†The declared vibration total value has been measured in accordance with a standard test method and may be used for comparing one tool with another.

The declared vibration total value may also be used in a preliminary assessment of exposure.

SCOPE: This HVLV gravity cup spray gun is designed for small touch up work and detail jobs and is compatible with solvent and water based paints. The high volume, low pressure [HVLV] technology can help meet the guide lines in the Environmental Protection Act 1990.

⚠ ATTENTION! Any other application is considered misuse.

3. AIR SUPPLY

FAILING TO COMPLY WITH THESE INSTRUCTIONS WILL RESULT IN YOUR AIR TOOL FAILING EARLY; THIS WILL NOT BE COVERED BY THE GUARANTEE.

To get the best from your spray gun you will need to connect it to a compressor easily able of supplying the large amount of air that it this type of product demands.

To make sure enough air reaches the gun, it should be supplied using a 3/8" diameter line or greater. If you are using an air tool on a hose over 25ft. long it is advisable to increase the bore of the hose to the next larger size available.

This air tool operates at a maximum pressure of 30psi or 43psi depending on model and must be controlled via a joint pressure regulator/water separator unit[†] which with proper maintenance will ensure a constant supply of dry air at all times (see illustration below). Water from condensation can build up inside the compressor tank and air lines: this will cause your equipment to rust if not properly dealt with.

[†]See the Draper air tool accessory range for a suitable unit.

Always check the air line output operating pressure before connecting the spray gun.

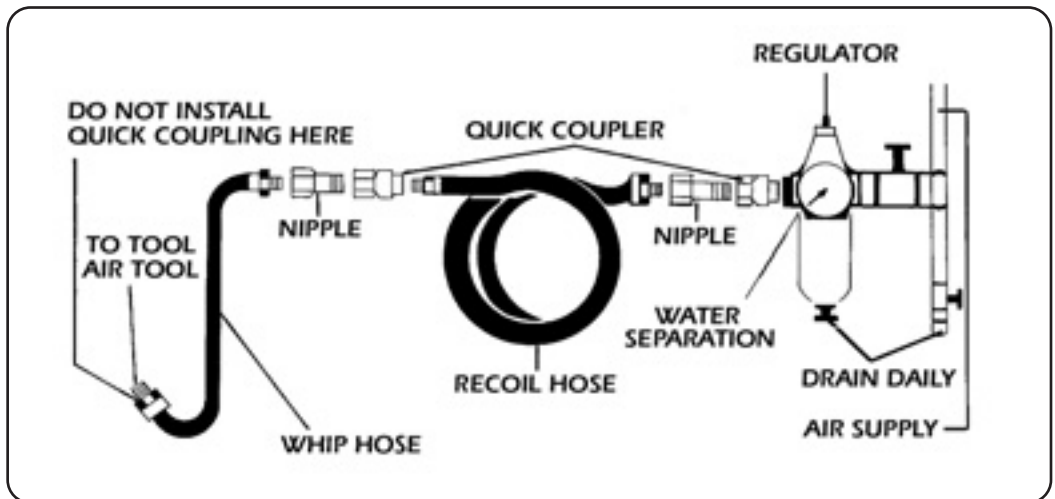

4. SAFETY INSTRUCTIONS

- ⚠ **ATTENTION!: KEEP FOR FUTURE REFERENCE.** This document is part of the product: keep them for the life of the product passing the on to any subsequent holder the product.
- ⚠ **ATTENTION!: Read this document fully before attempting to assemble, use or maintain your spray gun.**
- ⚠ **ATTENTION!: This spray gun is compatible with a variety of water based and solvent based materials.** A list of the materials used in the construction will be made available on request to validate compatibility with the coating materials to be used.
- ⚠ **WARNING!: Never point the spray gun at people or animals.**
- ⚠ **WARNING!: Never exceed the guns specified maximum working pressure.** See specification for details.
- ⚠ **WARNING!: Always wear personal protective equipment specially designed for use in a paint spraying environment to guard against harmful airborne pollutants and contact with paint related products. Match the equipment to the health risk.**
- ⚠ **WARNING!: Use in a well ventilated area away from any source of ignition to prevent fires or possible explosions.**
- ⚠ **WARNING!: All the spraying equipment and the work piece, if metallic, must be earthed.**
- ⚠ **Do not** attempt to modify the spray gun in any way.
- ⚠ **Always** read the literature supplied with the paint to ensure it is compatible with the equipment and any other paint material that you intend using.
- ⚠ **Never** leave the spray gun unattended. Disconnect it from the air supply when not in use.
- ⚠ **Always** disconnect the air supply and remove any paint from the pot before disassembling or cleaning the unit.
- ⚠ This spray gun is not designed for use in medical grade or food grade environments.
- ⚠ When disposing of excess paint or solutions used to clean the spray gun you must observe all national and local authority guidelines and laws. Respect and look after the environment.
- ⚠ This spray gun should be serviced by trained personnel only.
- ⚠ Only use original Draper spare parts to service and maintain this spray gun.
- ⚠ This spray gun must only be operated by persons trained to safely operate this type of equipment.
- ⚠ Only use nylon bristle brushes to clean the spray gun components. Do not use any metal objects as damage will occur possibly resulting in a poor spray pattern.

5. TYPICAL MATERIAL FLOW RATE

Stock no.	Nozzle	Material delivery
09708	0.8 - 1.0	65 - 100 ml/min.
09706	1.4 - 2.0	190 - 250 ml/min.
09709	0.8 - 1.0	70 - 110 ml/min.
09707	1.4 - 2.0	200 - 450 ml/min.

6. IDENTIFICATION GUIDE

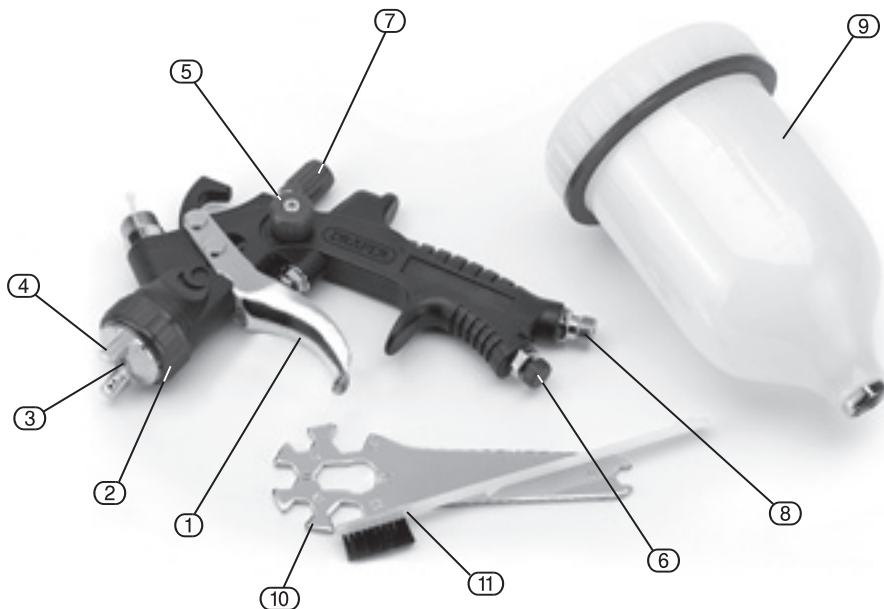

- | | |
|--------------------------|--------------------|
| ① Trigger. | ⑦ Paint control. |
| ② Air cap. | ⑧ Air inlet. |
| ③ Paint nozzle. | ⑨ Paint pot. |
| ④ Air diffuser horns. | ⑩ Service spanner. |
| ⑤ Spray pattern control. | ⑪ Cleaning brush. |
| ⑥ Air control. | |

- **UNPACKING:** After removing the packing material, make sure the product is in perfect condition and that there are no visible damaged parts. If in doubt, do not use the product and contact the dealer from whom it was purchased.
- The packaging materials (plastic bags, polystyrene, etc.), must be disposed of in an appropriate refuse collection container. These materials must not be left within the reach of children as they are potential sources of danger.

7. ASSEMBLY

Carefully remove everything from the packaging and compare it against the contents list. If anything appears to be missing please contact the place of purchase.

7.1 ATTACHING AN AIR LINE COUPLING (Fig.1):

After purchasing the spray gun and before initial use an air line coupling must be fitted that is compatible with your compressor's trailing hose.

- i. Select a suitable ¼" female thread air line coupling, for example Draper Stock no. 55061.
- ii. Wind a length of Draper PTFE tape stock no. 63389 around the thread.
- iii. Screw the coupling on to the spray gun.
- iv. The connection must be firm for an airtight union.



7.2 CONNECTING THE PAINT POT (Fig.2):

After purchasing the spray gun and before initial use, wash the spray gun through to clear the air and paint channels of any debris or dust.

- i. Turn the paint pot lid (A) anticlockwise to remove it.
- ii. Fill the paint pot with material.
- iii. Carefully refit the pot lid (A). Turn the lid anticlockwise a little to seat it correctly on the thread, before turning it clockwise to tighten.
- iv. Make sure the bleed screw (B) is screwed in to prevent paint loss.
- v. Screw the paint pot assembly into the top of the spray gun connector (C). Turn the pot clockwise until tight.

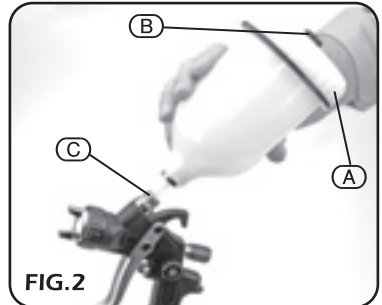

8. OPERATION & USE

Only when you are ready to begin spraying should you connect your air supply to the spray gun.

⚠ WARNING! Read and understand the safety instruction section of this document before attempting to operate your spray gun

Before each day's use this process should be followed to ensure your spray gun is set up for the best possible performance. Time spent setting up the gun and spraying test patterns each time is worthwhile exercise and will result in a quality finish when paired with a suitable air supply and a practiced spraying technique.

8.1 SPRAY GUN SETUP - SPRAY PATTERN CONTROL (Fig.3):

The spray pattern control (D) regulates the air flow out through the air diffuser horns (E) which in turn changes the shape of the spray pattern.

- i. Open the spray pattern control (D) anticlockwise to widen the pattern.
- ii. Closing the control (D) clockwise will make the spray pattern narrower.

FIG.3

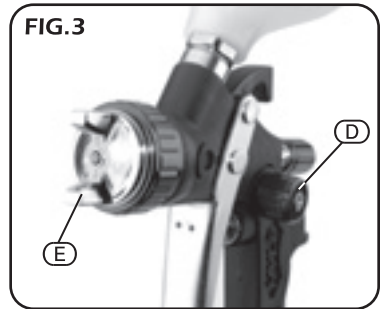

8.2 SPRAY GUN SETUP - AIR CONTROL (Fig.4):

The air control (F) regulates the volume of air passing through the gun. As the air passes out through the diffuser horns (E), it mixes with the paint being sprayed. This causes the paint to breakdown in to tiny individual droplets [atomization].

- i. Twist the air control (F) anticlockwise to increase the volume of air or clockwise to decrease the flow.

Ⓛ The 0 and Max. settings are stamped on either side of the spray gun, adjacent to the air flow control.

FIG.4

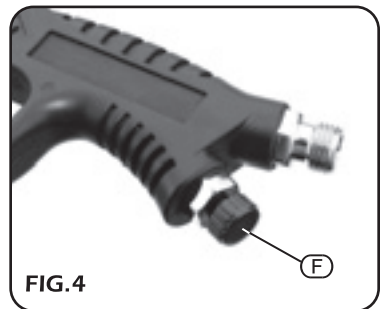

8.3 SPRAY GUN SETUP - PAINT CONTROL (Fig.5):

The paint control (G) adjusts the distance the trigger (H) can be pulled.

- i. Turn the paint control (G) clockwise to limit the distance the trigger can be pulled (H).
- ii. Closing the control (G) clockwise will make the spray pattern narrower.

⚠ CAUTION! Continuing to turn the paint control will release the spring tension on the fluid needle allowing removal.

FIG.5

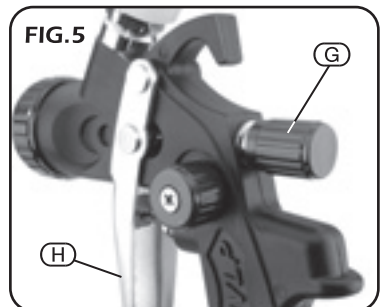

8.4 SPRAY GUN SETUP - TEST PATTERN (Fig.6-8):

A 'perfect' spray gun setup is only ever a temporary achievement; factors which affect this include the choice of material, nozzle & air cap size and the compressor conditions on the day.

Adjust the gun to a neutral starting setup and spray a test pattern. Judge the pattern; continuing to spray further tests and make fine adjustments until you are happy with the results.

- i. Set the air supply pressure and connect the spray gun.
- ii. Open the spray pattern control fully anti clockwise to give a wide pattern
- iii. Open the air control to Max.
- iv. Adjust the paint control anticlockwise so the trigger has full movement.
- v. Adjust the air diffuser horns so they are in the horizontal position - giving an upright spray pattern.
- vi. On a piece of white paper [or other suitable media] spray two test patterns: one holding the spray gun still and approx. 20cm away from the paper. The second keeping the gun parallel to paper while you make a short pass sideways.
- vii. If the shape of the spray pattern differs from the image (Fig.6) refer to the troubleshooting section of this document before proceeding.

If the shape, size and distribution of the spray droplets on the second test are largely uneven, it would suggest the atomization of the material is insufficient. Increase the air flow slightly until the droplets seems more uniform (Fig.7).

viii. Now adjust the air diffuser horns so they are vertical. Spray a test pattern laying down enough material for the paint to begin running (Fig.8).

- ix. If the paint appears very heavy it may mean the viscosity or material is not right for the nozzle size. Try reducing the flow control. If unsuccessful, select a smaller nozzle.

If the coverage appears too little it suggests the nozzle is too small. Step up a nozzle size and repeat the tests.

Begin spraying when you are happy with the results. Experience through practice will speed up the identification and adjustments necessary based on the spray guns results.

FIG.6



FIG.7

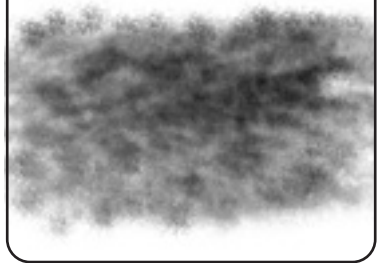

FIG.8



8.5 SPRAYING TECHNIQUE (Fig.9):

Hold the spray gun at a right angle to the work piece while maintaining an equal distance of approx. 20cm. Move the gun across the work piece keeping it parallel all the way. A fluid wrist action will be necessary.

Begin pulling the trigger before the leading edge of the work piece is reached, holding it in fully as you travel smoothly across and releasing after the trailing edge has been passed.

Difficult areas such as corners should be sprayed first.

When spraying a corner maintain the angle of 90°.

Paint needs to equally cover both surfaces leading away from the corner.

To hide the join and prevent streaking overlap by at least 50% across the previously painted surface.

FIG.9

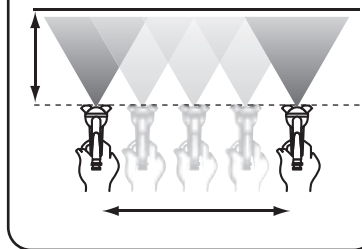

After each job and during prolonged breaks in spraying the gun must be cleaned thoroughly inside and out to stop any material drying and clogging it up.



- i. Empty the paint pot of any unused material into a suitable container for appropriate disposal.
- ii. Fill the pot with water and spray to flush the gun body through.

With the air supply disconnected:

- i. Remove the lid and paint pot. Place in a cleaning bath briefly to soak.
- ii. Remove the air cap; immerse in water and scrub any remaining paint with the cleaning brush supplied. Clear any clogged holes with the nozzle brush.
- iii. With the multi size spanner, remove the nozzle; immerse in water again clearing any clogged holes with the nozzle brush.
- iv. Carefully undo the paint control to release the spring tension on the needle. Store the control cap and spring to one side. Pull the trigger once and then with draw the needle. Immerse the needle and gun body in the bath to make sure all remaining paint is removed.
- v. Reassemble the spray gun components lubricating all nylon packing washers, and any moving parts that pivot or slide. Only apply a lubricant specifically designed for use on a spray gun.
- vi. When rebuilt, connect the gun to the air supply and operate the trigger for a short while to disperse any remaining water and dry the inside of the gun.

Do not use any metal objects to clean the nozzle or air holes as it will damage the spray gun and result in a poor spray pattern.

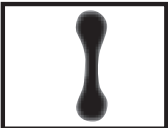
10. TROUBLESHOOTING

PROBLEM	PROBABLE CAUSE	SUGGESTED REMEDY
<p>Spray size generally uneven due to poor atomization.</p>	<p>1a. Too much paint entering air flow. 1b. Insufficient air hitting paint flow.</p>	<p>a1. Decrease paint flow or reduce the nozzle to the next size down. b1. Increase air flow on the spray gun's air control.</p>
<p>Intermittent spray.</p>	<p>1. Air is getting into the paint circuit.</p>	<p>1a. Tighten the nozzle up with the multi size spanner. 1b. Check the paint pot is not empty.</p>
<p>A lot of overspray.</p>	<p>1a. Spray gun distance from work piece. 1b. Technique.</p> <p>1c. Atomization too high.</p>	<p>1a. Maintain a distance of approx. 20cm. 1b. Make sure you are not flicking the gun on the leading or trailing edge (see 8.5 Spraying Technique). 1c. Reduce air flow on the spray gun's air control.</p>
<p>Badly formed spray pattern.</p> 	<p>1a. Nozzle or air cap alignment. 1b. Debris or dried paint blocking air cap or nozzle. 1c. Needle tip worn or damage.</p>	<p>1a. Check that both are correctly seated. 1b. Check and if necessary clean the air cap and nozzle. 1c. Replace needle assembly.</p>
<p>Lack of spray in the centre.</p> 	<p>1a. Not enough paint entering air flow. 1b. Too much air flow.</p>	<p>1a. Increase paint flow or step up the nozzle to the next size. 1b. Reduce air flow on the spray gun's air control.</p>
<p>Uneven fan shape.</p> 	<p>1a. Air cap holes blocked on one side. 1b. Needle tip and air cap worn or damaged nozzle.</p>	<p>1a. Clean the air cap thoroughly. 1b. Replace needle assembly.</p>
<p>Air or paint leaking.</p>	<p>1a. Sticking trigger or needle mechanism. 1b. Loose or worn packing washers.</p>	<p>1a. Lubricate all moving parts. 1b. Check tightness. If tight, replace and lubricate packing washers.</p>

NOTE: Any adjustments made to remedy a problem will alter the original test pattern results. Slight rebalancing may be necessary

- At the end of the product's working life, or when it can no longer be repaired, ensure that it is disposed of according to national regulations.
In all circumstances:
 - Do not abandon in the environment.
⚠ **Always** read the literature supplied with the paint to ensure it is compatible with the equipment and any other paint material that you intend using.

- **DRAPER TOOLS LIMITED,**
Hursley Road, Chandler's Ford,
Eastleigh, Hampshire. SO53 1YF. U.K.

- **Helpline:** (023) 8049 4344
- **Sales Desk:** (023) 8049 4333
- **Internet:** www.draper.co.uk
- **E-mail:** sales@drapertools.com
- **Sales Fax:** (023) 8049 4209
- **General Enquiries:** (023) 8026 6355

- **Service/Warranty Repair Agent**
For aftersales servicing or warranty repairs, please
contact the Draper Tools Helpline for details of an
agent in your local area.

YOUR DRAPER STOCKIST

OAJW120110