

***ENGLISH***

**DDL-7000A-7 Series  
INSTRUCTION MANUAL**

# CONTENTS

<b>I. SPECIFICATIONS</b> .....	<b>1</b>
1. Specifications of the sewing machine head.....	1
2. Specifications of the control box .....	1
<b>II. SET-UP</b> .....	<b>2</b>
1. Installation .....	2
2. Installing the pedal sensor.....	3
3. Connecting the connector.....	4
4. Installing the reactor box [Only for the EU type models].....	5
5. Installing the power switch .....	8
6. Attaching the connecting rod .....	10
7. Winding the bobbin thread.....	11
8. Adjusting the height of the knee lifter.....	12
9. Installing the thread stand .....	12
10. Lubrication.....	13
11. Adjusting the amount of oil (oil splashes).....	14
12. Attaching the needle.....	16
13. Setting the bobbin into the bobbin case.....	17
14. Adjusting the stitch length.....	17
15. Presser foot pressure .....	17
16. Hand lifter .....	17
17. Adjusting the height of the presser bar .....	18
18. Threading the machine head .....	18
19. Thread tension .....	19
20. Thread take-up spring .....	19
21. Adjusting the thread take-up stroke.....	19
22. Needle-to-hook relationship.....	20
23. Height of the feed dog .....	20
24. Tilt of the feed dog .....	21
25. Adjusting the feed timing .....	21
26. Counter knife .....	22
27. Pedal pressure and pedal stroke.....	22
28. Adjustment of the pedal .....	23
29. Marker dots on the handwheel .....	23
<b>III. FOR THE OPERATOR</b> .....	<b>24</b>
1. Operating procedure of the sewing machine .....	24
2. Operation panel built in the machine head.....	26
3. Operating procedure of the sewing pattern .....	28
4. Setting of functions .....	33
5. Digital types operation .....	35
6. Function setting list .....	36
7. Details of setting of the main functions.....	39
8. Stitch balance of back-tacking for lockstitch machine .....	45
9. How to set the machine head and to initialize data (the factory-set state at the time of shipment) .....	48
10. How to use the bobbin counter .....	49

<b>11. Initialization of function setting data.....</b>	<b>50</b>
<b>12. Password lock.....</b>	<b>52</b>
<b>13. About the USB.....</b>	<b>53</b>
<b>14. List of error codes.....</b>	<b>54</b>

# I. SPECIFICATIONS

## 1. Specifications of the sewing machine head

No.	Item	Model name	
		DDL-7000AS-7	DDL-7000AH-7
		Light- to medium-weight materials	Heavy-weight materials
1	Max. sewing speed	Stitch length less than 4mm 5,000sti/min Stitch length 4mm or more 4,000sti/min	Stitch length less than 5mm 4,000sti/min Stitch length 5mm or more 3,500sti/min
2	Factory-set sewing speed at the time of shipment	4,000sti/min	3,500sti/min
3	Stitch length	5mm	5mm( ※ )
4	Needle bar stroke	30.7±0.5mm	35±0.5mm
5	Thread take-up lever stroke	Link thread take-up lever 107mm (106 to 112mm)	Link thread take-up lever 112mm (108 to 115mm)
6	Needle	DB×1 (#14) #14 to 18 134(Nm90) Nm90 to Nm110	DP×5 (#21) #20 to 23 134(Nm130) Nm125 to Nm160
7	Thread counts that are supported	#60 to #8 (200 to 600dtex)	#30 to #8 (600 to 1200dtex)
8	Amount of lift of the presser foot	Manual: 5.5 mm, By knee-lifter: 13 mm	
9	Lubrication	Replenishment of oil reservoir (capacity: 450 ml)	
10	Lubrication method	Forced lubrication method	
11	Lubricating oil	JUKI CORPORATION OIL 7 (equivalent to ISO VG7) or NEW DEFRIX OIL No. 1 (equivalent to ISO VG7)	
12	Drive system	Main-shaft direct-drive system	
13	Electrical box	Integral with the machine head	
14	Power switch	3-phase / EU-Type	
15	Motor used	AC servomotor, 550 W	
16	External dimensions	Distance from machine arm to needle: 260 mm; height of the machine arm: 130 mm Arm size: 432 mm x 105 mm; bed size: 476 mm x 178 mm Entire length: 603 mm	
17	Operating temperature / humidity range	Temperature : 5°C to 35°C/ Humidity : 35% to 85%	
18	Mass of machine head	Completed machine head 34 kg	
19	LED light (Provided as standard)	Illumination is adjustable in five steps.	
20	Noise	Equivalent continuous emission sound pressure level (L <sub>pA</sub> ) at the workstation: A-weighted value of 81.0 dBA ; (Includes K <sub>pA</sub> = 2.5 dBA) ; according to ISO 10821- C.6.2 -ISO 11204 GR2 at 4,000 sti/min.	Equivalent continuous emission sound pressure level (L <sub>pA</sub> ) at the workstation: A-weighted value of 83.0 dBA ; (Includes K <sub>pA</sub> = 2.5 dBA) ; according to ISO 10821- C.6.2 -ISO 11204 GR2 at 4,000 sti/min.

**(Caution) Sewing speed differs according to the sewing conditions.**

\* Stitch length can be maximized to 7 mm by changing over the feed dial and the throat plate with the optional feed dial (22971402) and the optional throat plate (23645807).

## 2. Specifications of the control box

Supply voltage	Single phase 220 to 240V	3-phase 200 to 240V Single phase 100 to 120V	Single phase 220 to 240V CE
Frequency	50Hz/60Hz	50Hz/60Hz	50Hz/60Hz
Operating environment	Temperature : 0 to 35°C Humidity : 90% or less	Temperature : 0 to 35°C Humidity : 90% or less	Temperature : 0 to 35°C Humidity : 90% or less
Input	210VA	210VA	210VA



## II. SET-UP

### 1. Installation

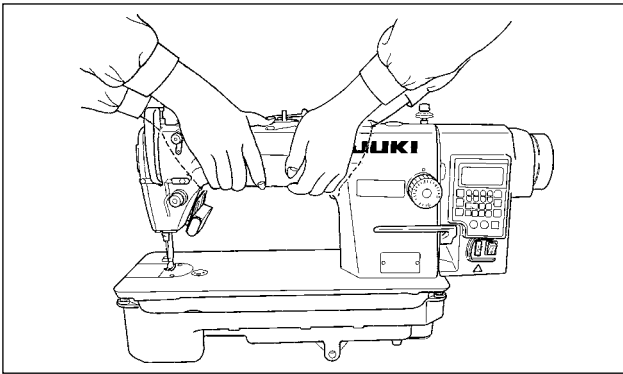

1) Carry the sewing machine while holding the machine arm with two persons as shown in the figure.

**(Caution) Never hold the handwheel since it rotates.**

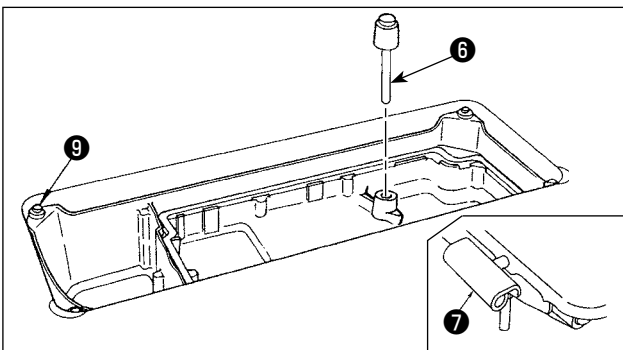
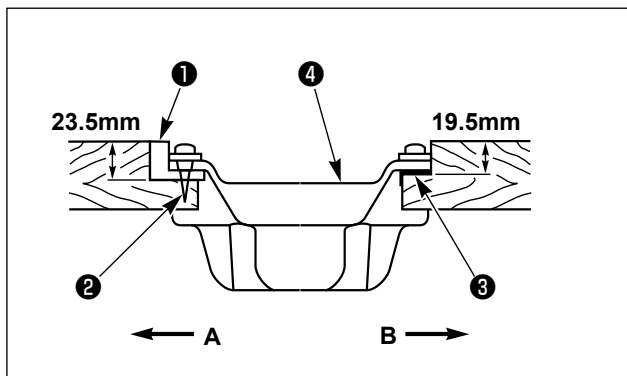
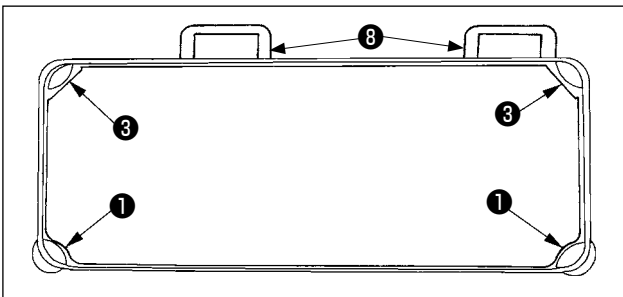

5) Fit knee lifter pressing rod **6**. Fit hinge **7** into the opening in the machine bed, and fit the machine head to table rubber hinge seat **8** before placing the machine head on cushions **9** on the four corners.

6) Securely attach head support rod **10** to the table until it goes no further.

**\* Be sure to install the machine head support bar supplied with the unit.**

7) Draw out cable **11** of the control box through cable draw-out hole **12** to route it to the underside of the sewing machine table.

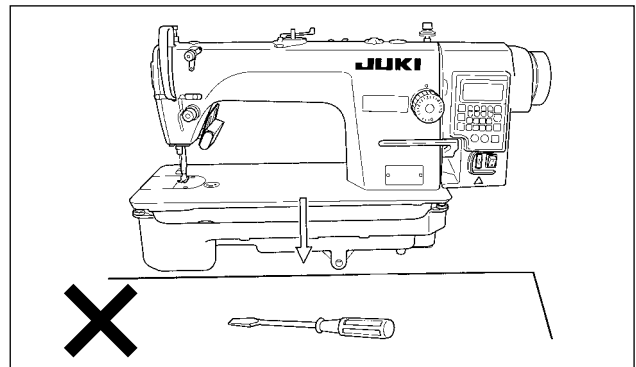

2) Place the sewing machine on a horizontal and plane place when placing it and do not place any protruding thing such as a screwdriver or the like.

3) Adjust so that the oil pan is supported at the four corners of the table. Mount rubber hinge seat **8** on the table and fix it on the table with a nail.

4) Fix two rubber seats **1** on side **A** (operator's side) using nails **2** as illustrated above. Fix two cushion seats **3** on side **B** (hinged side) using a rubber-based adhesive. Then place oil pan **4** on the fixed seats.

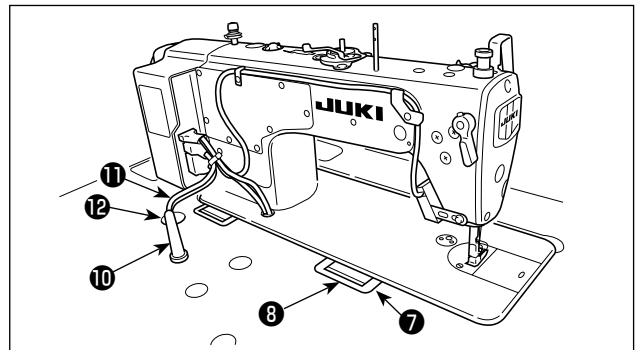

## 2. Installing the pedal sensor

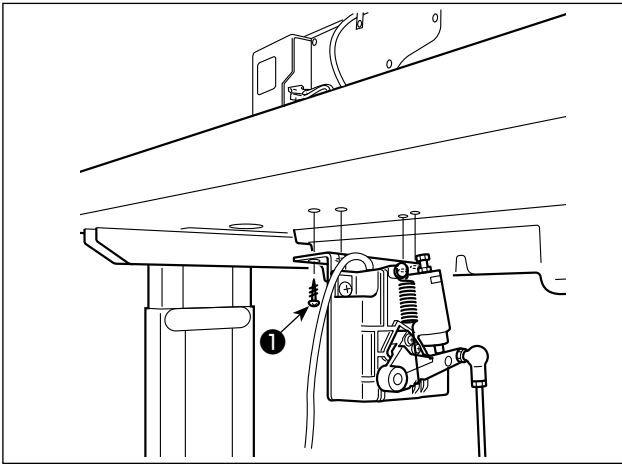

- 1) Install the pedal sensor to the table with mounting screws ❶ supplied with the unit.  
It is necessary to install the pedal sensor at such a position that the connecting rod is perpendicular to the table.
- 2) After the completion of installation of the pedal sensor on the table, place the sewing machine head on the table.

### 3. Connecting the connector

#### WARNING :



- To protect against personal injury resulting from abrupt start of the sewing machine, be sure to turn the power OFF, unplug the machine and wait for five minutes or more before installing the pedal sensor.
- To prevent damage of device caused by maloperation and wrong specifications, be sure to connect all the corresponding connectors to the specified places. (If any of the connectors is inserted into a wrong connector, not only the device corresponding to the connector can break but also it can start abruptly, inviting the risk of personal injury.)
- To prevent personal injury caused by maloperation, be sure to lock the connector with lock.
- Do not connect the power plug until the connection of cords is completed.
- Fix the cords while taking care not to forcibly bend them or excessively clamp them with staples.
- As for the details of handling respective devices, read carefully the Instruction Manuals supplied with the devices before handling the devices.

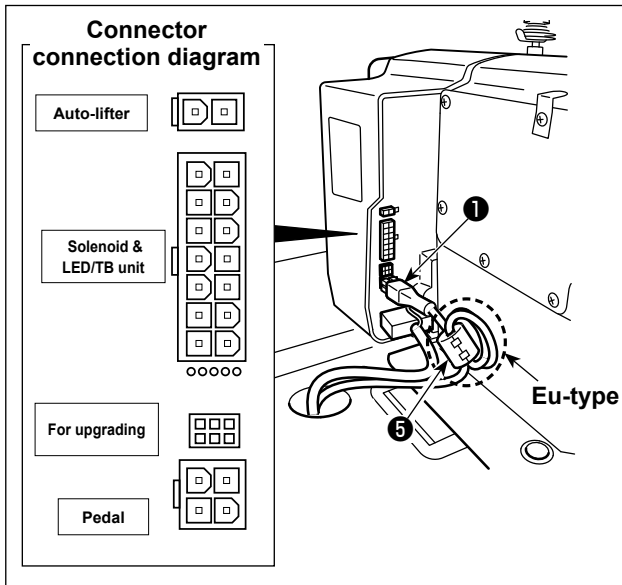

**Caution** Do not insert the power plug into the wall outlet. Check to be sure that the power switch is turned OFF.

#### [EU-type models]

Install ring core ⑤ .  
For one ring core ⑤ , clamp the pedal sensor cable ① after winding the cable round the torus of the ring core three times.

- 1) Connect pedal sensor cable ① supplied with the unit to the control box.  
Refer to the connector connection diagram for connecting ports of the cables.

**Caution** Be sure to fully insert the connectors into the corresponding ports until they are locked.

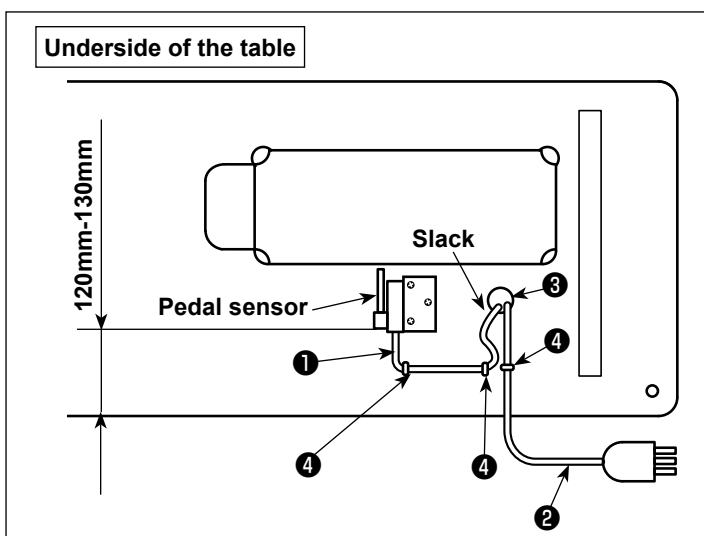

- 2) Secure pedal sensor cable ① and AC input cable ② with staples ④ .

**Caution** The lateral position of the pedal sensor should be adjusted so that the connecting rod is positioned straight. Then, secure the pedal sensor at that position.

#### 4. Installing the reactor box [Only for the EU type models]

\* For the EU-type models, install the reactor box that is supplied with the sewing machine.

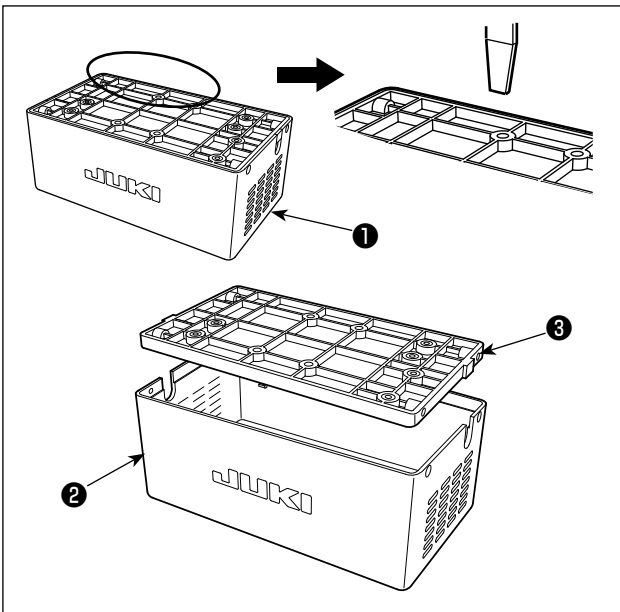

1) Detach reactor cover ② from reactor box ① to separate from reactor base asm. ③ .

\* The reactor cover can be detached with ease by inserting a tool that has a thin flat tip such as a flat-blade screwdriver between the cover and base.

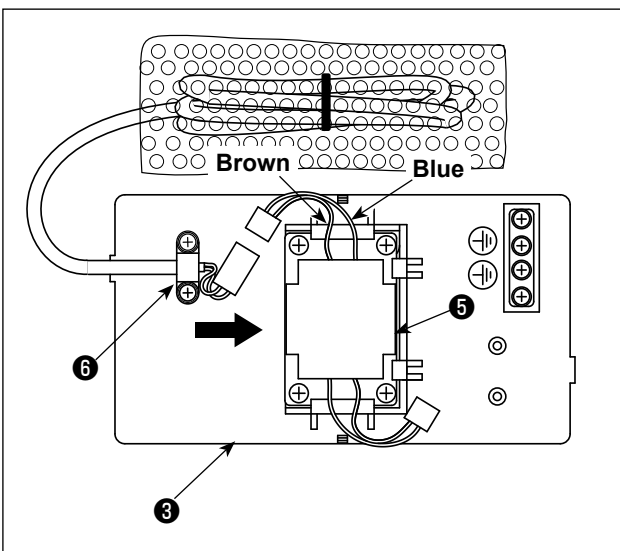

2) Slide reactor ⑤ in the direction of the arrow to insert into reactor base asm. ③ .

- Caution**
1. When inserting the reactor, detach bundled wire clamp ⑥ beforehand.
  2. Insert reactor ⑤ into the reactor base asm. while facing brown and blue lead wires side upward.

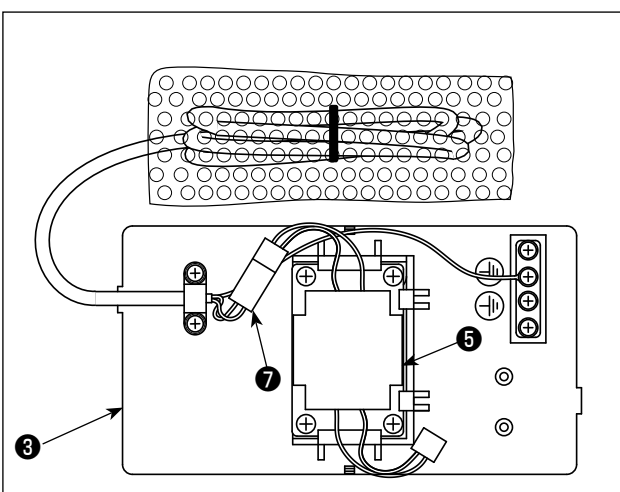

3) Connect the connector ⑦ of the power cord that is fixed to reactor base asm. ③ to the connector of reactor ⑤ .

**Caution** Be sure to insert the former fully into the latter until the connector is locked.

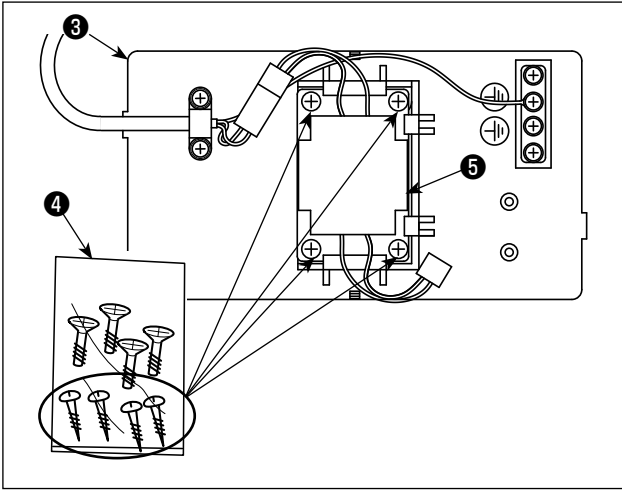

4) Take out wood screws (ST4.2 x 25) from screw bag 4 . Secure reactor base asm. 3 and reactor 5 to the undersurface of sewing machine table with the wood screws (at four locations).

**Caution** Refer to the instruction figure shown in the following step of procedure 11) for the mounting positions of the reactor cover and reactor base asm.

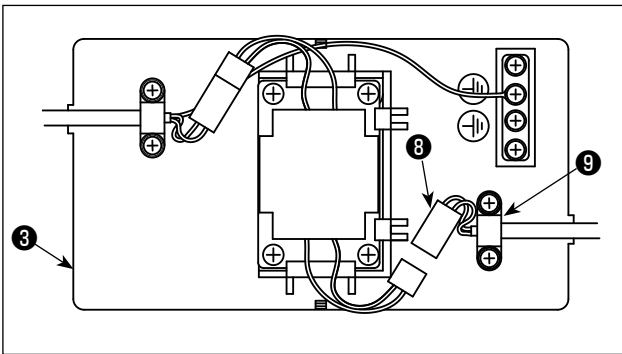

5) Secure power cord asm. 8 coming from the electrical box to reactor base asm. 3 with bundled wire clamp 9 .

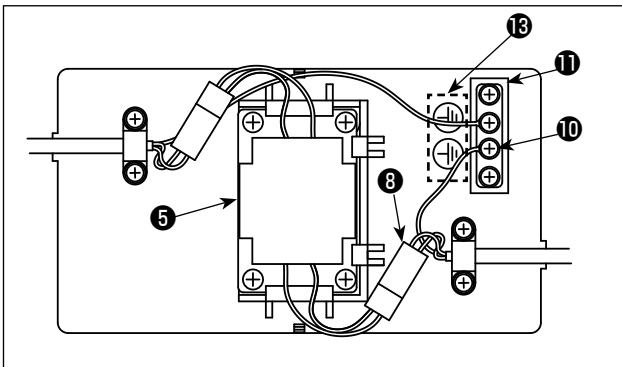

6) Connect the connector of power cord asm. 8 to connector of reactor 5 .  
 7) Secure earth terminal 10 of power cord asm. 8 to earth base 11 with a screw.

**Caution** Secure the earth terminal to the screw with earth mark 13 .

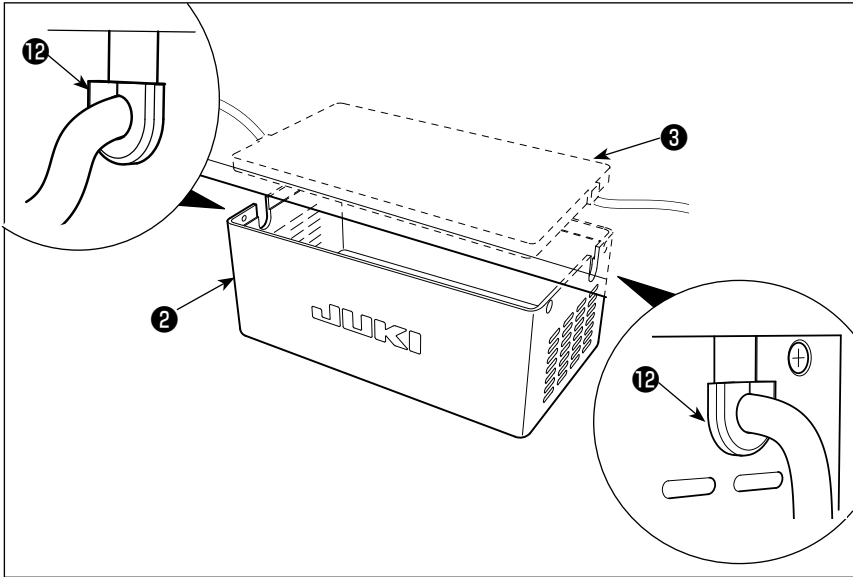

8) Fit reactor cover ② over reactor base asm. ③ .



Take care not to allow the cord to be caught under reactor cover ② .

Pass the power cord through cord bushing ⑫ . Then, insert the power cord into the slit portion of reactor cover ② and hold it with reactor base asm. ③ .

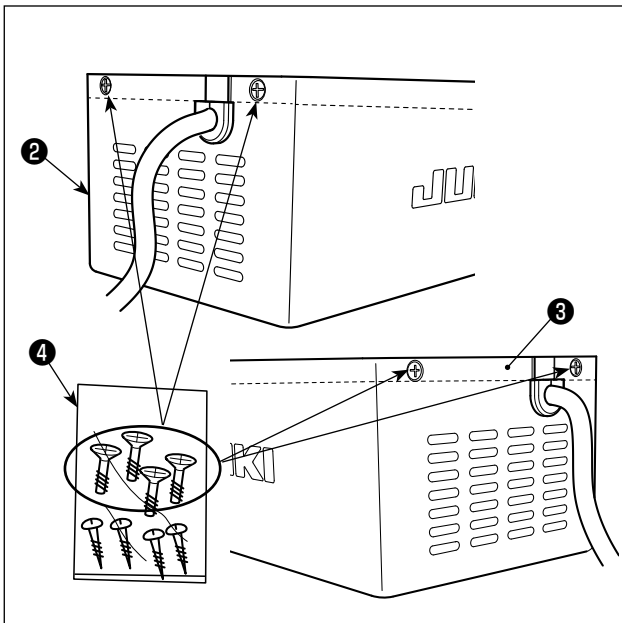

9) Take out reactor cover fixing screws from screw bag ④ . Secure reactor cover ② to reactor base asm. ③ with the fixing screws (at four locations).

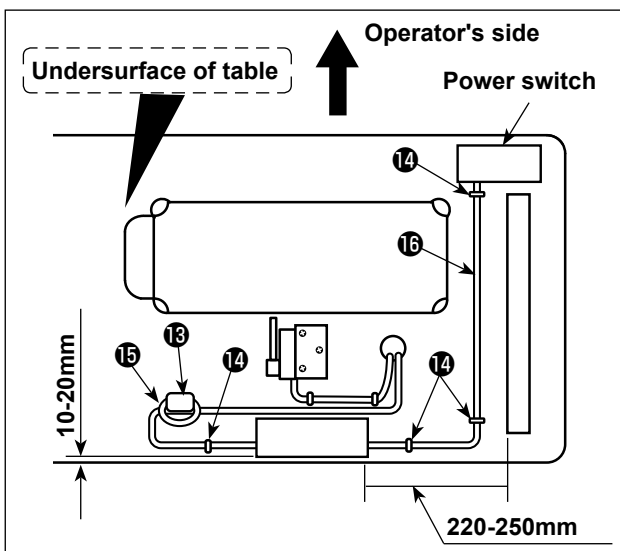

10) Install ring core ⑬ .

For core ⑬ , clamp the power cord of the electrical box after winding the cable round the torus of the ring core twice.

11) Attach AC input cable ⑮ and output cable ⑯ on the underside of table using supplied staple ⑭ . At this time, take care not to cross the input- and output-cables ⑮⑯ .

## 5. Installing the power switch



### WARNING :

1. Be sure to attach the ground wire (green/yellow) to the specified location (on the ground side).
2. Take care not to allow terminals to come in contact with each other.
3. When you close the power switch cover, take care not to allow the cord to be caught under the cover.
4. In case you want to use the 3-phase, 200 - 240 V type electrical box for the single-phase, 100 - 120 V power supply, contact your nearest JUKI Service Station in prior.

### (1) 3-phase 200 to 240V

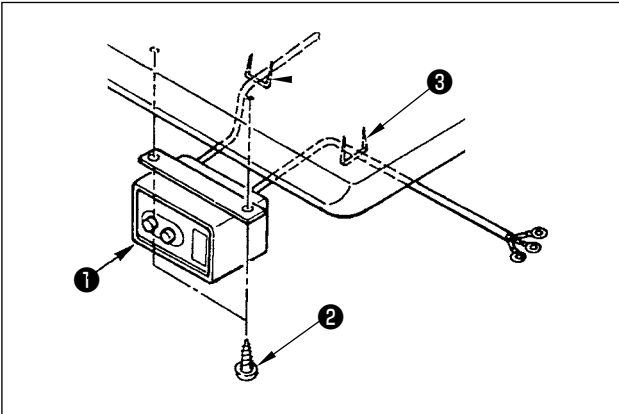

#### 1) Installing the power switch

Fix power switch ① under the machine table with wood screws ② .

Fix the cable with staples ③ supplied with the machine as accessories in accordance with the forms of use.

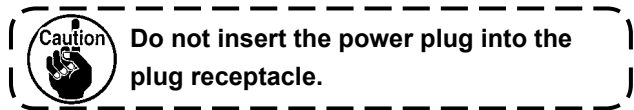
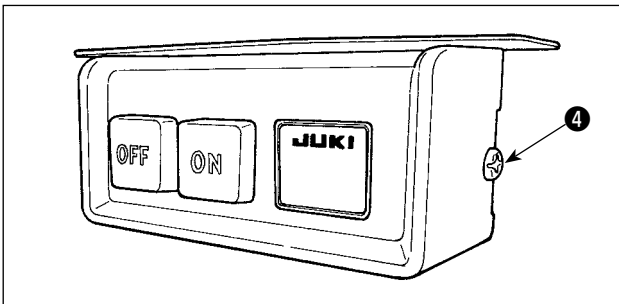

**Do not insert the power plug into the plug receptacle.**

#### 2) Remove screw ④ on the side face of the power switch cover to open the power switch cover.

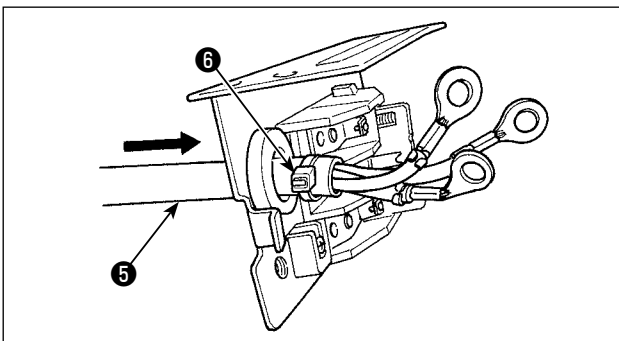

#### 3) Pass AC input cord ⑤ ,through the rear face of the power switch. Bundle the cord with cable clip band ⑥ to secure it.

4) Securely fix the terminals of the AC input cord by tightening the screws at the specified locations.

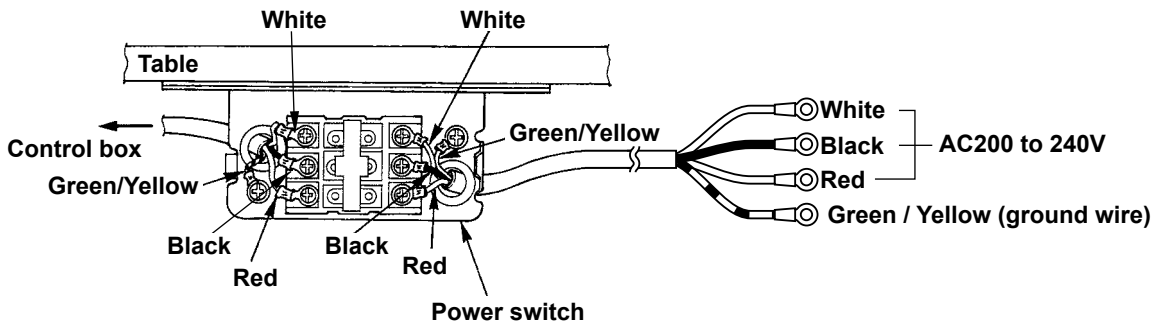

1. Be sure to prepare the power plug ❶ which conforms to the safety standard.
2. Be sure to connect the ground lead (green/yellow) to the grounding side.
3. The colors of wires to be connected are white, black and red from the top for both sides.  
Check the wires and secure with screws.

5) Close the power switch cover. Tighten screw ❷ on the side face of the power switch cover.



In case you want to use the 3-phase, 200 - 240 V type electrical box for the single-phase, 100 - 120 V power supply, contact your nearest JUKI Service Station in prior.

## (2) Single phase 220 to 240V

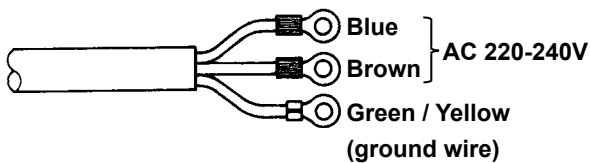

1. Be sure to prepare the power plug which conforms to the safety standard.
2. Be sure to connect the ground lead (green/yellow) to the grounding side.

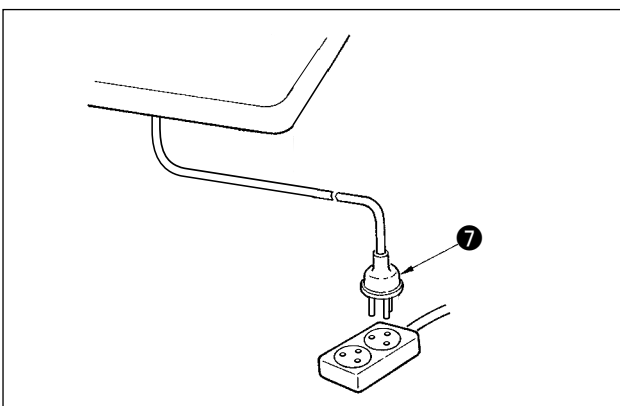

Check that the power switch is in the OFF state. Then, insert the power plug ❷ coming from the power switch into the plug receptacle.



In prior to the connection of the power plug ❷, re-check the supply voltage specification indicated on the control box.

\* The power plug ❷ is different in shape according to the destination of the sewing machine.



## 6. Attaching the connecting rod



### WARNING :

To protect against possible personal injury due to abrupt start of the machine, be sure to start the following work after turning the power off and a lapse of 5 minutes or more.

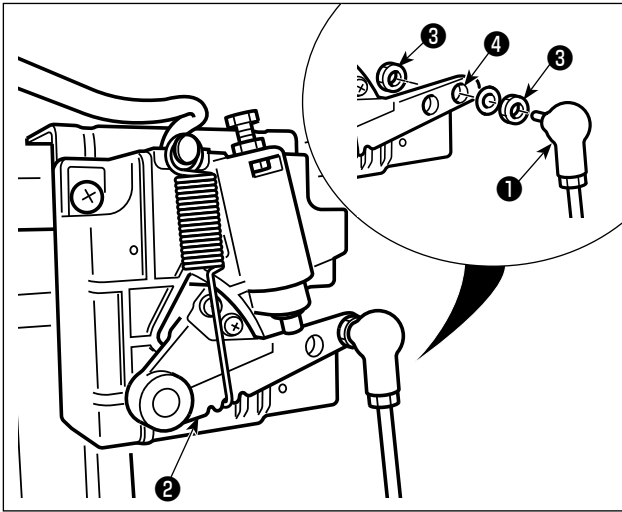

Fix connecting rod ① to installing hole ④ of pedal lever ② with nut ③ .

## 7. Winding the bobbin thread

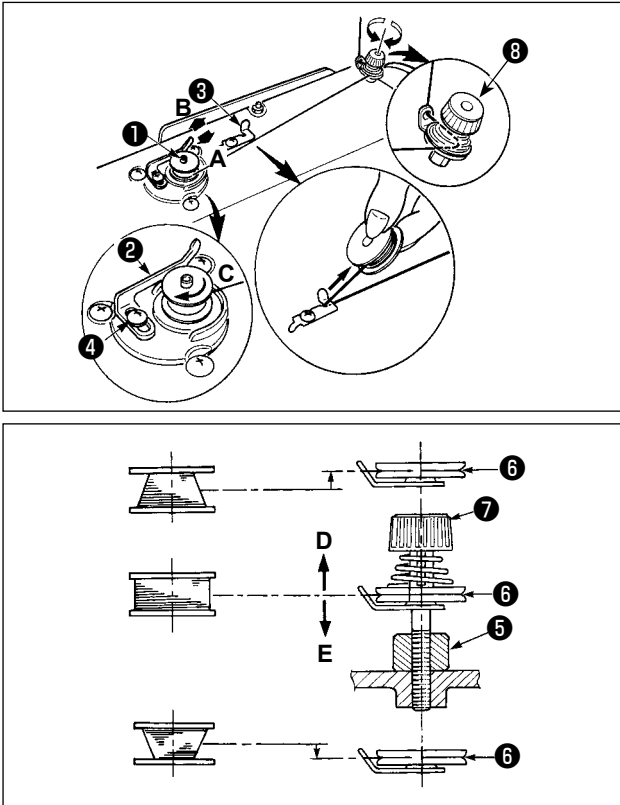

- 1) Insert the bobbin deep into the bobbin winder spindle ① until it will go no further.
- 2) Pass the bobbin thread pulled out from the spool rested on the right side of the thread stand following the order as shown in the figure on the left. Then, wind clockwise the end of the bobbin thread on the bobbin several times.  
(In case of the aluminum bobbin, after winding clockwise the end of the bobbin thread, wind counterclockwise the thread coming from the bobbin thread tension several times to wind the bobbin thread with ease.)
- 3) Press the bobbin winding lever ② in the direction of **A** and start the sewing machine. The bobbin rotates in the direction of **B** and the bobbin thread is wound up. The bobbin winder spindle ① automatically as soon as the winding is finished.
- 4) Remove the bobbin and cut the bobbin thread with the thread cut retainer ③ .
- 5) When adjusting the winding amount of the bobbin thread, loosen setscrew ④ and move bobbin winding lever ② to the direction of **A** or **B**. Then tighten setscrew ④ .  
To the direction of **A** : Decrease  
To the direction of **B** : Increase

- 6) In case that the bobbin thread is not wound evenly on the bobbin, remove the handwheel, loosen screw ⑤ and adjust the height of bobbin thread tension ⑧ .
  - It is the standard that the center of the bobbin is as high as the center of thread tension disk ⑥ .
  - Adjust the position of thread tension disk ⑥ to the direction of **D** when the winding amount of the bobbin thread on the lower part of the bobbin is excessive and to the direction **E** when the winding amount of the bobbin thread on the upper part of the bobbin is excessive.
 After the adjustment, tighten screw ⑤ .
- 7) To adjust the tension of the bobbin winder, turn the thread tension nut ⑦ .



1. When winding the bobbin thread, start the winding in the state that the thread between the bobbin and thread tension disk ⑥ is tense.
2. When winding the bobbin thread in the state that sewing is not performed, remove the needle thread from the thread path of thread take-up and remove the bobbin from the hook.
3. There is the possibility that the thread pulled out from the thread stand is loosened due to the influence (direction) of the wind and may be entangled in the handwheel. Be careful of the direction of the wind.

## 8. Adjusting the height of the knee lifter



### WARNING :

Be sure to turn the power OFF before the following work in order to prevent personal injury due to unintentional starting of the sewing machine.

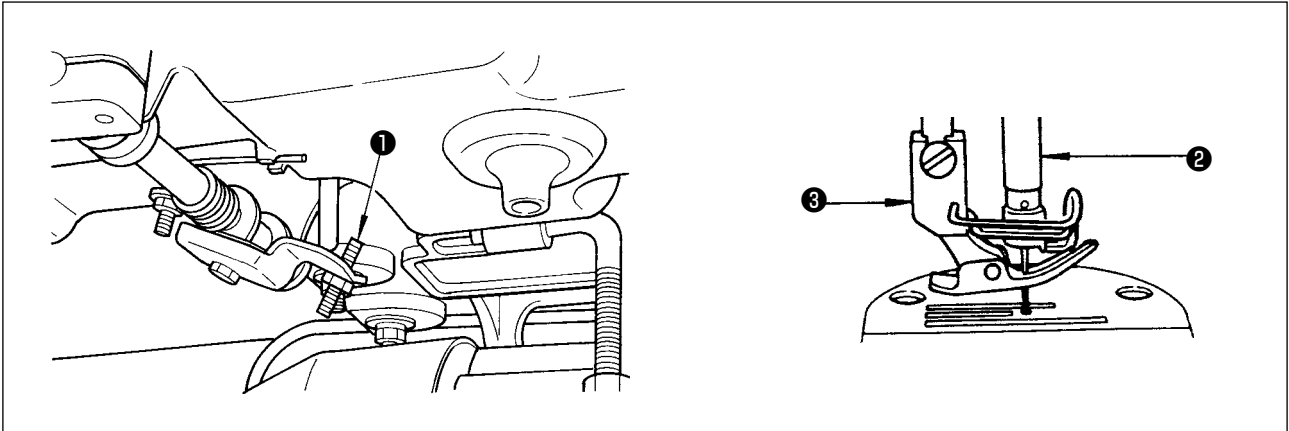

- 1) The standard height of the presser foot lifted using the knee lifter is 10 mm.
- 2) You can adjust the presser foot lift up to 13 mm using knee lifter adjust screw ① .
- 3) When you have adjusted the presser foot lift to over 10 mm, be sure that the bottom end of needle bar ② in its lowest position does not hit presser foot ③ .

## 9. Installing the thread stand

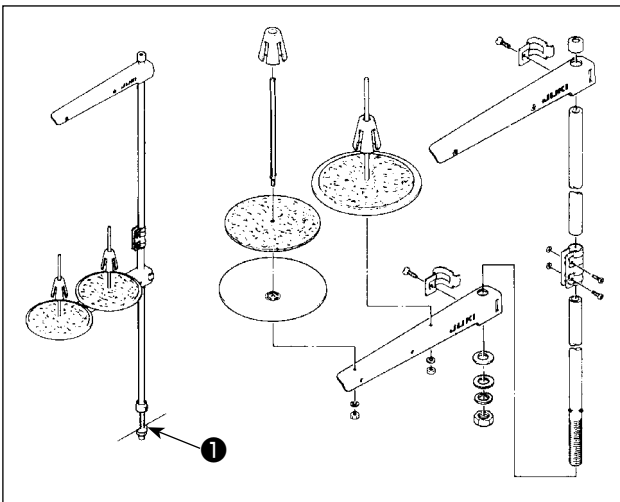

- 1) Assemble the thread stand unit, and insert it in the hole in the machine table.
- 2) Tighten nut ① .

## 10. Lubrication

### WARNING :



1. Do not connect the power plug until the lubrication has been completed so as to prevent accidents due to abrupt start of the sewing machine,
2. To prevent the occurrence of an inflammation or rash, immediately wash the related portions if oil adheres to your eyes or other parts of your body.
3. If oil is mistakenly swallowed, diarrhea or vomiting may occur. Put oil in a place where children cannot reach.

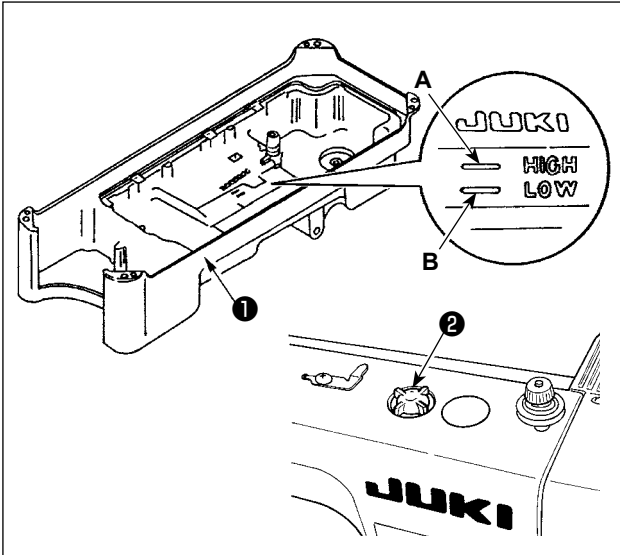

- 1) Before starting the sewing machine, fill oil pan ① with JUKI MACHINE OIL #7 up to HIGH mark A.
- 2) Add oil before the oil surface comes down to reach the LOW mark B.
- 3) When you operate the machine after lubrication, you will see splashing oil through oil sight window ② if the lubrication is adequate.
- 4) Note that the amount of the splashing oil is unrelated to the amount of the lubricating oil.



1. When you use a new sewing machine or a sewing machine after an extended period of disuse, use the sewing machine after performing break-in at 2,000 sti/min or less.
2. For the oil lubrication, purchase JUKI NEW DEFRIX OIL No. 1 (Part No. : MDFRX1600C0) or JUKI MACHINE OIL #7 (Part No. : MML007600CA).
3. Be sure to lubricate clean oil.
4. When the oil surface is lower than the LOW mark, the oiling may be inconsistent. To prevent inconsistent oiling, add oil before the oil surface comes down to reach the LOW mark.

## 11. Adjusting the amount of oil (oil splashes)



### WARNING :

Be extremely careful about the operation of the machine since the amount of oil has to be checked by turning the hook at a high speed.

### (1) Confirmation of the amount of oil in the hook

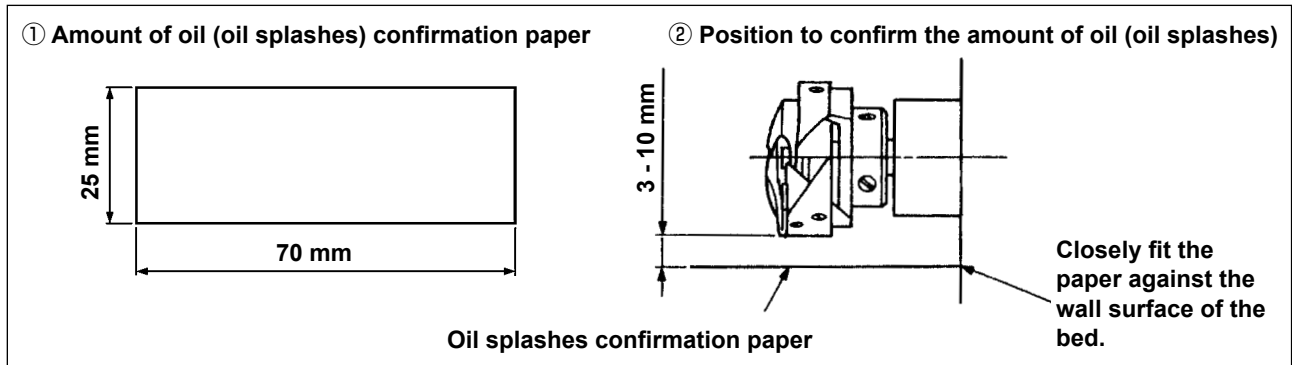

\* When carrying out the procedure described below in 2, remove the slide plate and take extreme caution not to allow your fingers to come in contact with the hook.

- 1) If the machine has not been sufficiently warmed up for operation, make the machine run idle for approximately three minutes. (Moderate intermittent operation)
- 2) Place the amount of oil (oil spots) confirmation paper under the hook immediately after the machine stops running.
- 3) Confirm the height of the oil surface in the oil reservoir is within the range between “HIGH” and “LOW”.
- 4) Confirmation of the amount of oil should be completed in five seconds. (Check the period of time with a watch.)

### (2) Adjusting the amount of oil (oil spots) in the hook

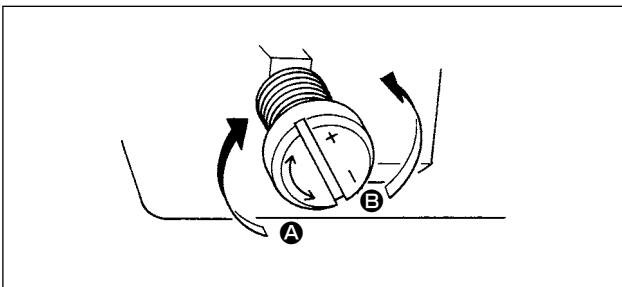

- 1) Turning the oil amount adjustment screw attached on the hook driving shaft front bushing in the “+” direction (in direction **A**) will increase the amount of oil (oil spots) in the hook, or in the “-” direction (in direction **B**) will decrease it.
- 2) After the amount of oil in the hook has been properly adjusted with the oil amount adjustment screw, make the sewing machine run idle for approximately 30 seconds to check the amount of oil in the hook.

### (3) Sample showing the appropriate amount of oil in the hook

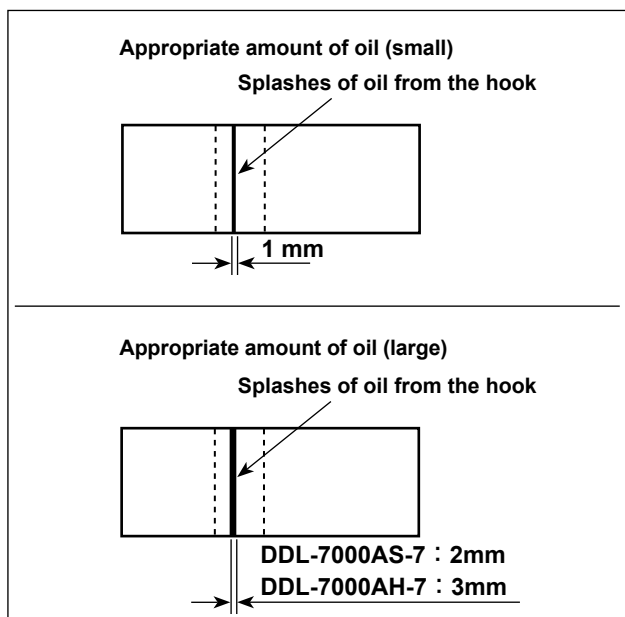

1) The amount of oil shown in the samples on the left should be finely adjusted in accordance with sewing processes.

Be careful not to excessively increase/decrease the amount of oil in the hook. (If the amount of oil is too small, the hook will be seized (the hook will be hot). If the amount of oil is too much, the sewing product may be stained with oil.)

2) Adjust the amount of oil in the hook so that the oil amount (oil splashes) should not change while checking the oil amount three times (on the three sheets of paper).

### (4) Confirmation of the amount of oil supplied to the face plate parts

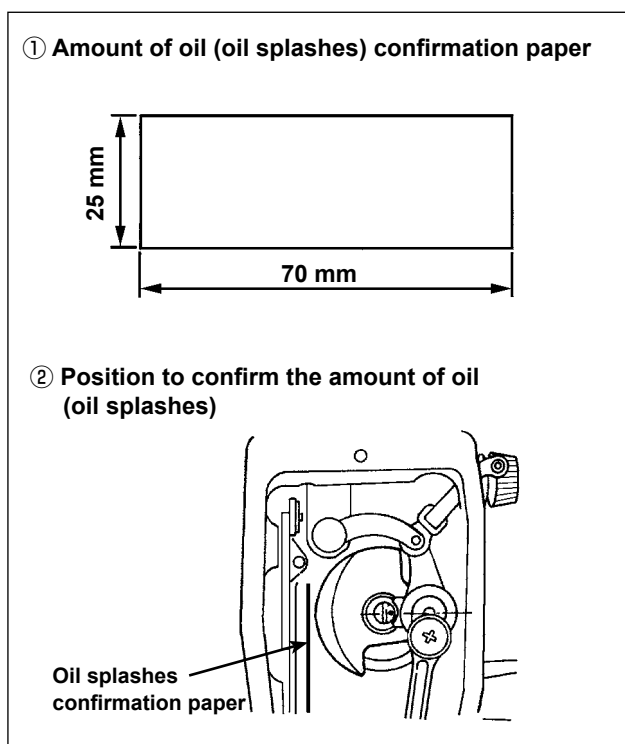

\* When carrying out the work described below in 2), remove the face plate and take extreme caution not to allow your fingers to come in contact with the thread take-up lever.

- 1) If the machine has not been sufficiently warmed up for operation, make the machine run idle for approximately three minutes. (Moderate intermittent operation)
- 2) Place the amount of oil (oil spots) confirmation paper under the hook immediately after the machine stops running.
- 3) Confirm the height of the oil surface in the oil reservoir is within the range between "HIGH" and "LOW".
- 4) The time required for the confirmation of the amount of oil (oil splashes) should be completed in ten seconds. (Measure the period of time with a watch.)

### (5) Adjusting the amount of oil supplied to the face plate parts

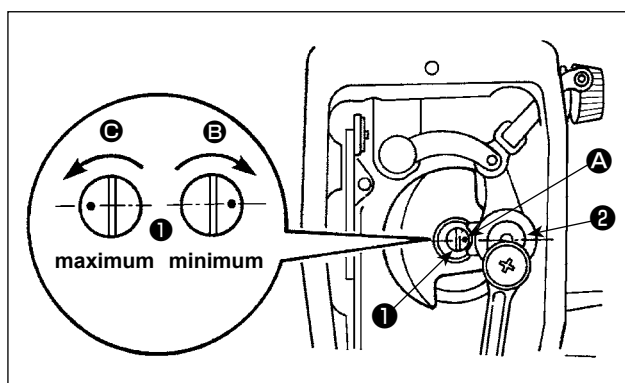

- 1) Adjust the amount of oil supplied to the thread take-up and needle bar crank ② by turning adjust pin ①.
- 2) The minimum amount of oil is reached when marker dot A is brought close to needle bar crank ② by turning the adjust pin in direction B.
- 3) The maximum amount of oil is reached when marker dot A is brought to the position just opposite from the needle bar crank by turning the adjust pin in direction C.

## (6) Sample showing the appropriate amount of oil supplied to the face plate parts

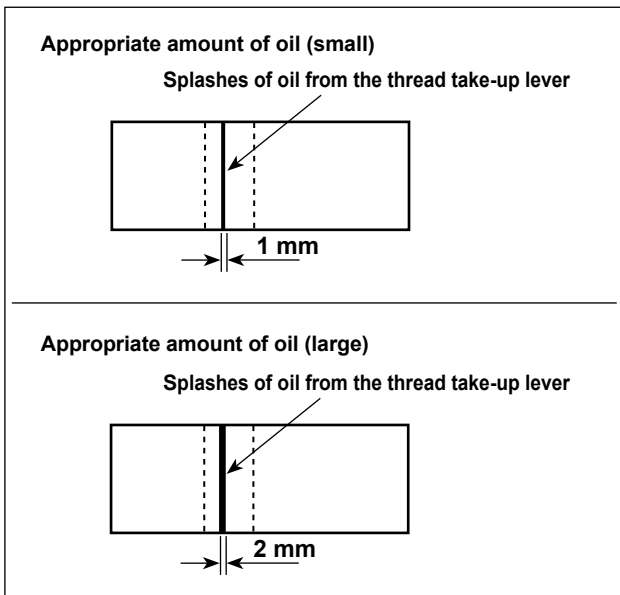

- 1) The state given in the figure shows the appropriate amount of oil (oil splashes). It is necessary to finely adjust the amount of oil in accordance with the sewing processes. However, do not excessively increase/decrease the amount of oil in the hook. (If the amount of oil is too small, the hook will be seized (the hook will be hot). If the amount of oil is too much, the sewing product may be stained with oil.)
- 2) Adjust the amount of oil in the hook so that the oil amount (oil splashes) should not change while checking the oil amount three times (on the three sheets of paper).

## 12. Attaching the needle



### WARNING :

Be sure to turn the power OFF before the following work in order to prevent personal injury due to unintentional starting of the sewing machine.

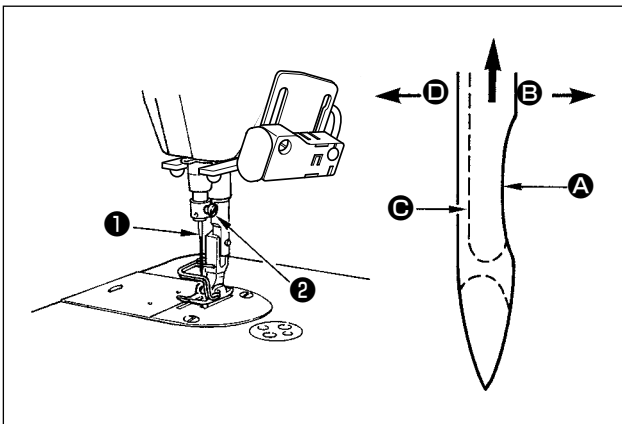

Use the specified needle for the machine. Use the proper needle in accordance with the thickness of thread used and the kinds of the materials.

- 1) Turn the handwheel until the needle bar reaches the highest point of its stroke.
- 2) Loosen screw ②, and hold needle ① with its indented part A facing exactly to the right in direction B.
- 3) Insert the needle fully into the hole in the needle bar in the direction of the arrow until the end of hole is reached.
- 4) Securely tighten screw ②.
- 5) Check that long groove C of the needle is facing exactly to the left in direction D.



When polyester filament thread is used, if the indented part of the needle is tilted toward operator's side, the loop of thread becomes unstable. As a result, hangnail of thread or thread breakage may occur. For the thread that such phenomenon is likely to occur, it is effective to attach the needle with its indented part slightly slanting on the rear side.

### 13. Setting the bobbin into the bobbin case

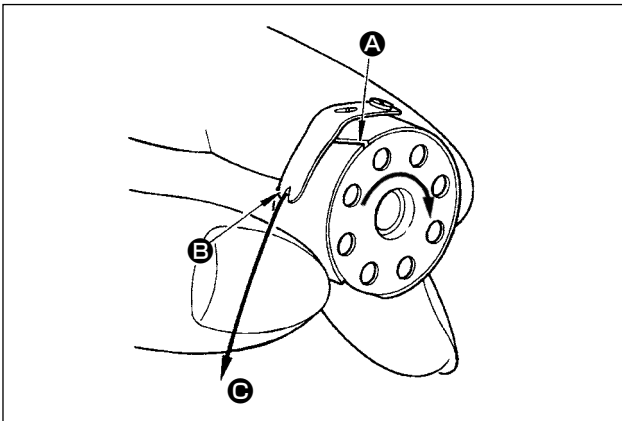

- 1) Pass the thread through thread slit **A**, and pull the thread in direction **C**. By so doing, the thread will pass under the tension spring and come out from notch **B**.
- 2) Check that the bobbin rotates in the direction of the arrow when thread is pulled.

### 14. Adjusting the stitch length

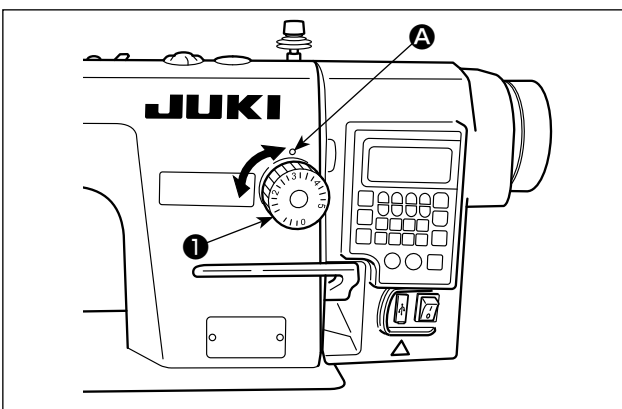

\* The dial calibration is in millimeters.

- 1) Turn stitch length dial **1** in the direction of the arrow, and align the desired number to marker dot **A** on the machine arm.

### 15. Presser foot pressure

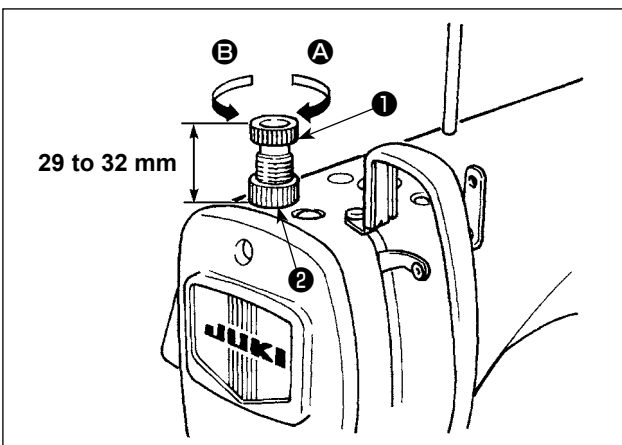

- 1) Loosen nut **2**. As you turn presser spring regulator **1** clockwise (in direction **A**), the presser foot pressure will be increased.
  - 2) As you turn the presser spring regulator counter-clockwise (in direction **B**), the pressure will be decreased.
  - 3) After adjustment, tighten nut **2**.
- The standard value of the pressure regulating thumb screw is 29 to 32 mm.

### 16. Hand lifter

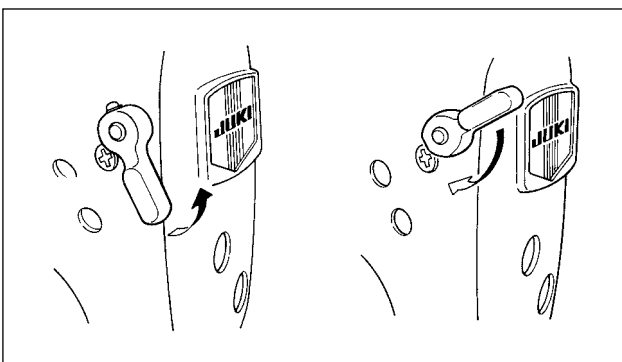

- 1) The presser foot is lifted by moving the lever upward.
- 2) The presser foot is lowered by moving the lever downward.



## 17. Adjusting the height of the presser bar



### WARNING :

Be sure to turn the power OFF before the following work in order to prevent personal injury due to unintentional starting of the sewing machine.

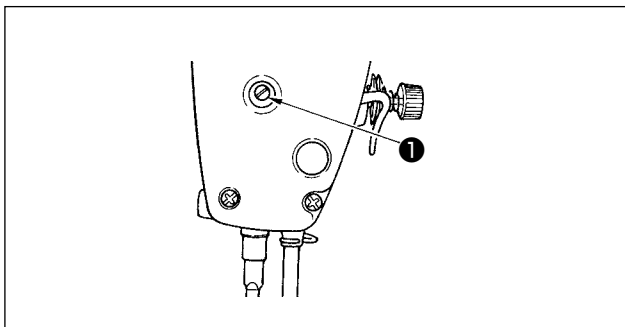

- 1) Loosen setscrew ❶, and adjust the presser bar height or the angle of the presser foot.
- 2) After adjustment, securely tighten the setscrew ❶.

## 18. Threading the machine head



### WARNING :

Be sure to turn the power OFF before the following work in order to prevent personal injury due to unintentional starting of the sewing machine.

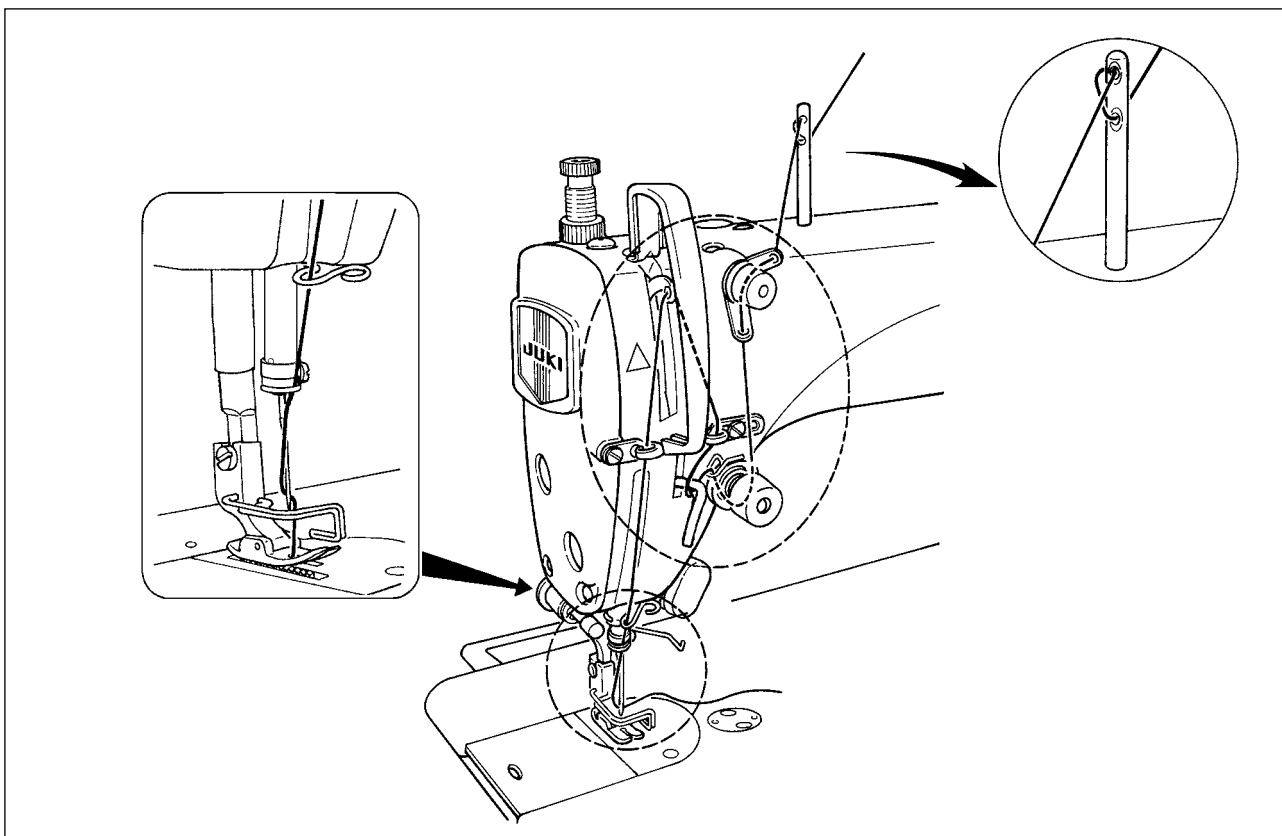

## 19. Thread tension

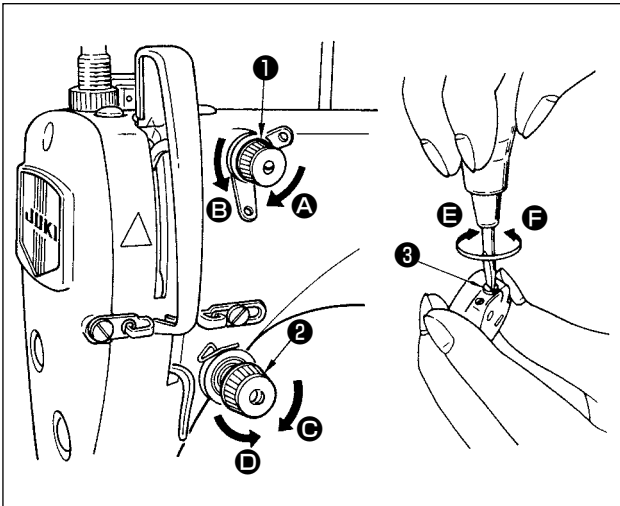

### (1) Adjusting the needle thread tension

- 1) The length of thread remaining at the needle tip after thread trimming is shortened by turning tension regulating nut No. 1 ① clockwise in direction **A**.
- 2) It is lengthened by turning the nut counterclockwise in direction **B**.
- 3) The needle thread tension is increased by turning tension regulating nut No. 2 ② clockwise in direction **C**.
- 4) It is decreased by turning the nut counterclockwise in direction **D**.

### (2) Adjusting the bobbin thread tension

- 1) The bobbin thread tension is increased by turning tension regulating screw ③ clockwise in direction **E**.
- 2) It is decreased by turning the screw counterclockwise in direction **F**.

## 20. Thread take-up spring

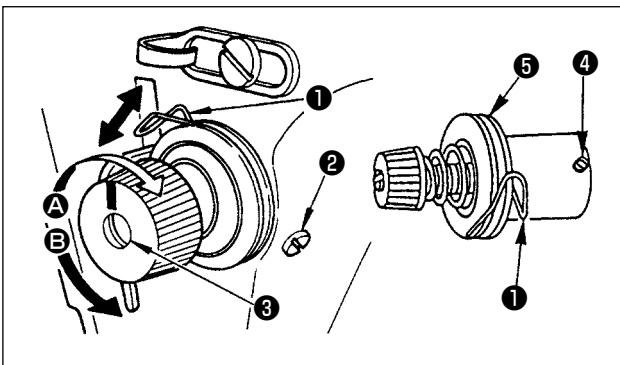

### (1) Changing the stroke of thread take-up spring ①

- 1) Loosen setscrew ②.
- 2) As you turn tension post ③ clockwise (in direction **A**), the stroke of the thread take-up spring will be increased.
- 3) As you turn the knob counterclockwise (in direction **B**), the stroke will be decreased.

### (2) Changing the pressure of thread take-up spring ①

- 1) Loosen setscrew ②, and remove thread tension ③.
- 2) Loosen setscrew ④.
- 3) As you turn tension post ③ clockwise (in direction **A**), the pressure will be increased.
- 4) As you turn the tension post counterclockwise (in direction **B**), the pressure will be decreased.

## 21. Adjusting the thread take-up stroke



### WARNING :

Be sure to turn the power OFF before the following work in order to prevent personal injury due to unintentional starting of the sewing machine.

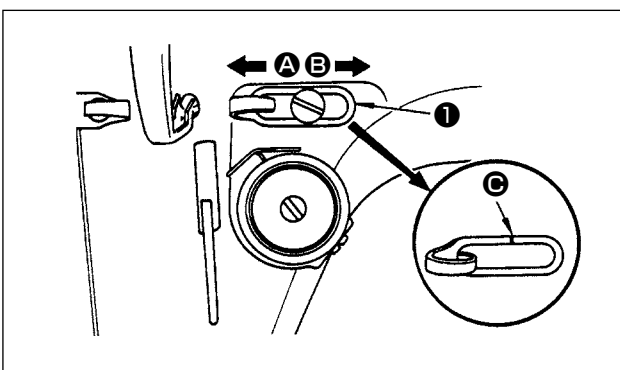

- 1) When sewing heavy-weight materials, move thread guide ① to the left (in direction **A**) to increase the length of thread pulled out by the thread take-up.
- 2) When sewing light-weight materials, move thread guide ① to the right (in direction **B**) to decrease the length of thread pulled out by the thread take-up.
- 3) Normally, thread guide ① is positioned in a way that marker line **C** is aligned with the center of the screw.

## 22. Needle-to-hook relationship



### WARNING :

Be sure to turn the power OFF before the following work in order to prevent personal injury due to unintentional starting of the sewing machine.

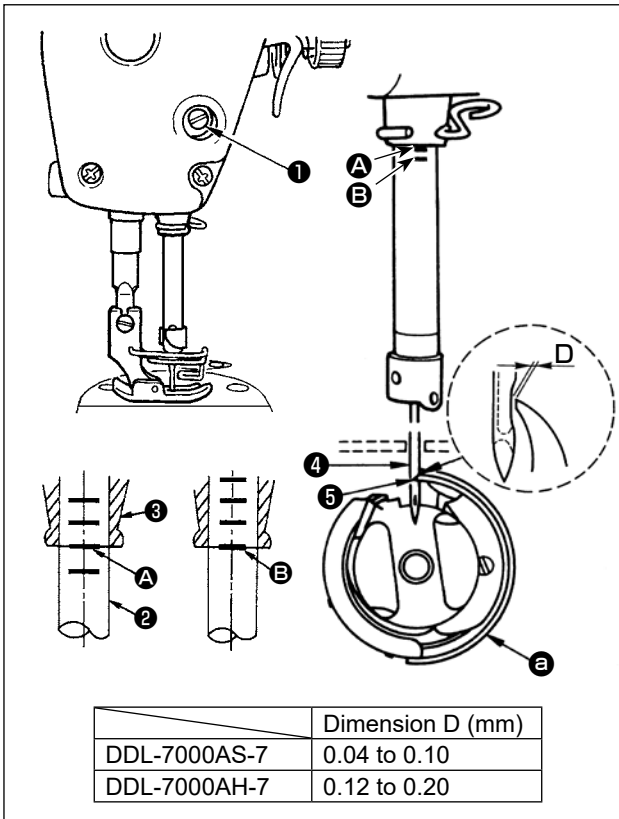

(1) Adjust the timing between the needle and the hook as follows :

1) Turn the handwheel to bring the needle bar down to the lowest point of its stroke, and loosen set-screw ① .

(Adjusting the needle bar height)

2) Align marker line ④ on needle bar ② with the bottom end of needle bar lower bushing ③ , then tighten setscrew ① .

(Adjusting position of the hook ②)

3) Loosen the three hook setscrews, turn the handwheel and align marker line ⑤ on ascending needle bar ② with the bottom end of needle bar lower bushing ③ .

4) After making the adjustments mentioned in the above steps, align hook blade point ⑥ with the center of needle ④ . Provide a clearance of 0.04 mm to 0.1 mm (reference value) between the needle and the hook, then securely tighten setscrews in the hook.



If the clearance between the blade point of hook and the needle is smaller than the specified value, the blade point of hook will be damaged. If the clearance is larger, stitch skipping will result.

## 23. Height of the feed dog



### WARNING :

Be sure to turn the power OFF before the following work in order to prevent personal injury due to unintentional starting of the sewing machine.

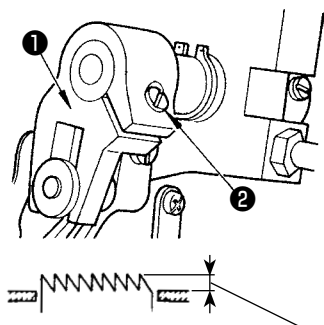

0.75 to 0.85 mm (DDL7000AS-7)

1.15 to 1.25 mm (DDL7000AH-7)

To adjust the height of the feed dog :

① Loosen screw ② of crank ① .

② Move the feed bar up or down to make adjustment.

③ Securely tighten screw ② .



If the clamping pressure is insufficient, the motion of the forked portion becomes heavy.

## 24. Tilt of the feed dog



### WARNING :

Be sure to turn the power OFF before the following work in order to prevent personal injury due to unintentional starting of the sewing machine.

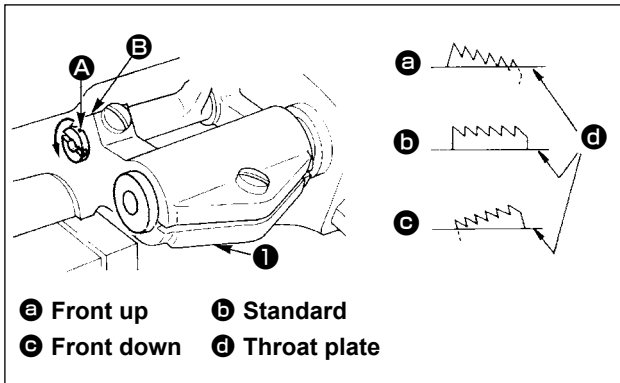

- 1) The standard tilt (horizontal) of the feed dog is obtained when marker dot **A** on the feed bar shaft is aligned with marker dot **B** on feed rocker **1**.
- 2) To tilt the feed dog with its front up in order to prevent puckering, loosen the setscrew, and turn the feed bar shaft 90° in the direction of the arrow, using a screwdriver.
- 3) To tilt the feed dog with its front down in order to prevent uneven material feed, turn the feed bar shaft 90° in the opposite direction from the arrow.



Whenever the feed dog tilt is adjusted, the feed dog height will be changed. So, it is necessary to check the height after tilt adjustment.

## 25. Adjusting the feed timing



### WARNING :

Be sure to turn the power OFF before the following work in order to prevent personal injury due to unintentional starting of the sewing machine.

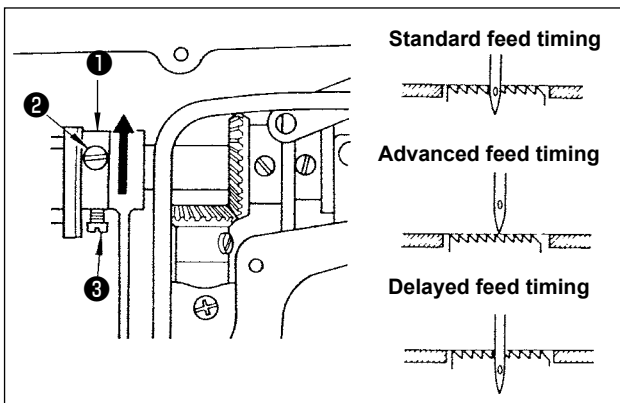

- 1) Loosen screws **2** and **3** in feed eccentric cam **1**, move the feed eccentric cam in the direction of the arrow or opposite direction of the arrow, and firmly tighten the screws.
- 2) For the standard adjustment, adjust so that the top surface of feed dog and the top end of needle eyelet are flush with the top surface of throat plate when the feed dog descends below the throat plate.
- 3) To advance the feed timing in order to prevent uneven material feed, move the feed eccentric cam in the direction of the arrow.
- 4) To delay the feed timing in order to increase stitch tightness, move the feed eccentric cam in the opposite direction from the arrow.



Be careful not to move the feed eccentric cam too far, or else needle breakage may result.

## 26. Counter knife



### WARNING :

Be sure to turn the power OFF before the following work in order to prevent personal injury due to unintentional starting of the sewing machine.



When sharpening again the knife ❶ blade, extra special care must be taken on the handling of the knife.

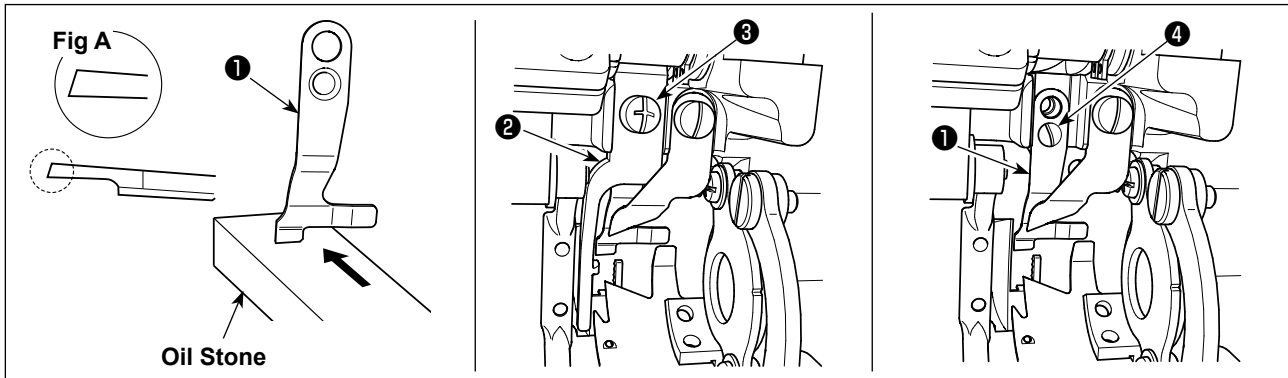

\* In the case the thread cannot be trimmed sharply, re-sharpen counter knife ❶ as illustrated in Fig. A before the knife has become dull and re-place it correctly.

- 1) Loosen setscrew ❸ of bobbin case opening lever ❷ , and remove the bobbin case opening lever.
- 2) Loosen setscrew ❹ , and remove counter knife ❶ .
- 3) To install the counter knife ❶ , follow the above procedure in reverse order.

## 27. Pedal pressure and pedal stroke



### WARNING :

Be sure to turn the power OFF before the following work in order to prevent personal injury due to unintentional starting of the sewing machine.

For General Application

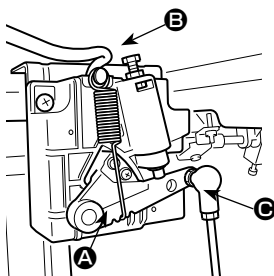

Adjust the force required to operate the foot pedal

Spring **A** : Downward force adjustment

Bolt **B** : Heeling back force adjustment

Hole **C** : Pedal stroke adjustment

## 28. Adjustment of the pedal



### WARNING :

Be sure to turn the power OFF before the following work in order to prevent personal injury due to unintentional starting of the sewing machine.

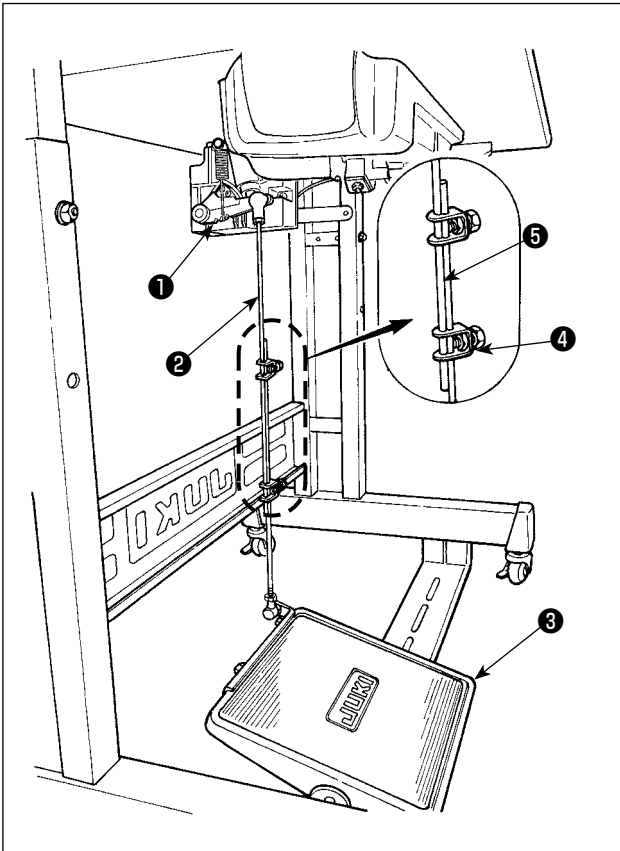

### (1) Installing the connecting rod

1) Move pedal ③ to the right or left as illustrated by the arrows so that motor control lever ① and connecting rod ② are straightened.

### (2) Adjusting the pedal angle

1) The pedal tilt can be freely adjusted by changing the length of the connecting rod.  
2) Loosen adjust screw ④, and adjust the length of connecting rod ⑤.

## 29. Marker dots on the handwheel

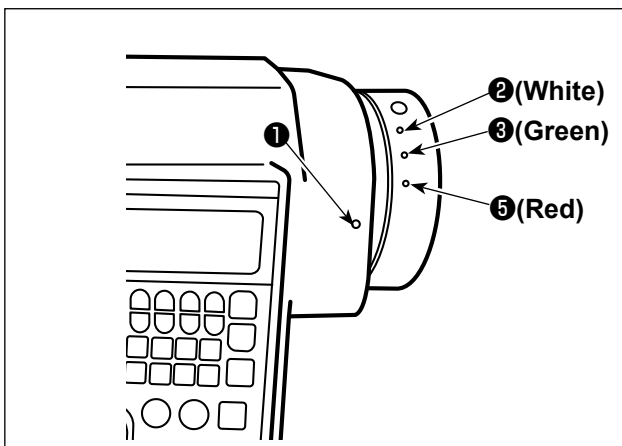

The upper stop position of the needle bar is the position at which marker dot ① on the cover is aligned with white marker dot ② on the handwheel.

With respect to the operating timing of the thread trimming cam, the thread trimming cam operates at the time when marker dot ① on the cover is aligned with green marker dot ③ on the handwheel.

## III. FOR THE OPERATOR

### 1. Operating procedure of the sewing machine

\* The switch configuration differs with the specifications.

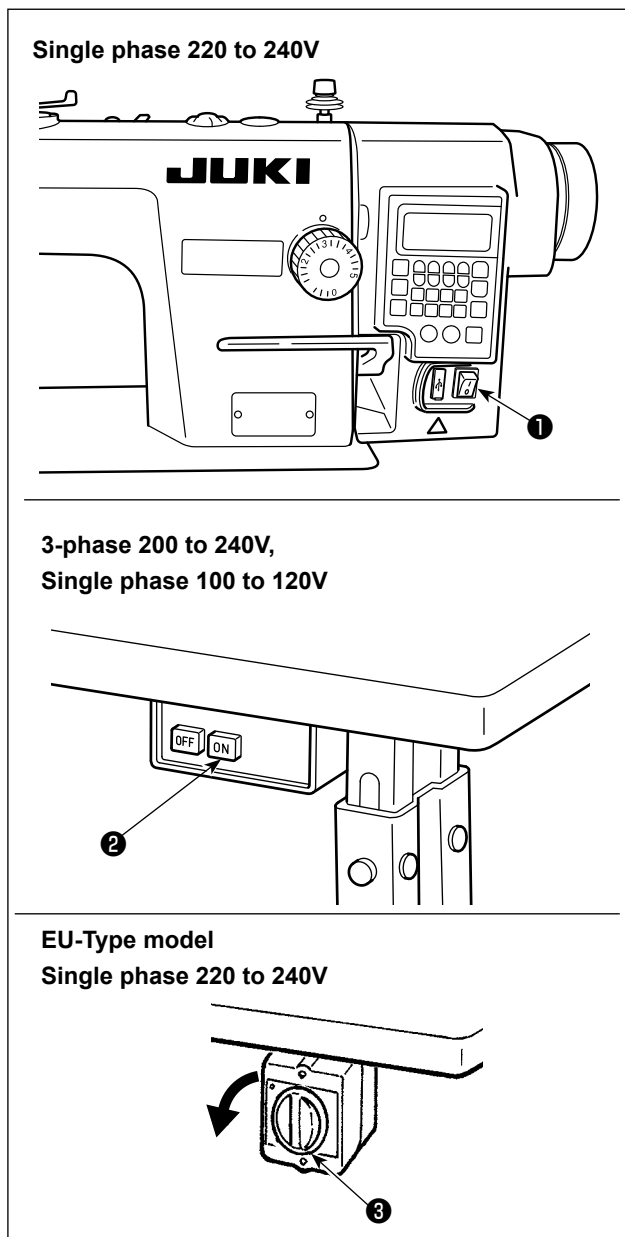

#### 1) Turning the power ON with the power switch

The power to the sewing machine is placed in the ON state when the "I" mark side of power switch ❶ (1ø 220 - 240V type) is pressed; or in the OFF state when the "0" mark side is pressed.

The power to the sewing machine is placed in the ON state when the ON button of power switch ❷ (3ø 200 - 240V type) is pressed; or in the OFF state when the OFF button is pressed.

The power to the sewing machine is placed in the ON state when the knob of power switch ❸ (EU type, 1ø 220 - 240V type) is turned by 90 degrees counterclockwise; or in the OFF state when it is turned clockwise to return to its home position.

1. Do not strongly tap the power switch by hand.

2. If the power indicator LED on the panel does not light up after having turned ON the power switch, immediately turn OFF the power switch and check the supply voltage.

When you want to re-turn ON power switch after carrying out the aforementioned steps, it is necessary to wait for five minutes or more after you have turned OFF power switch.

3. Do not place your hand or anything under the needle since the needle bar may automatically move according to the memory switch setting when you turn ON the power to the sewing machine.



#### 2) When you depress the back part of pedal, the needle bar and the presser lifting motor carry out their initial operation to allow the sewing machine to start sewing.

If you attempt to start sewing without depressing the back part of pedal, the warning message screen will be displayed. To prevent this, be sure to start sewing after depressing the back part of pedal.

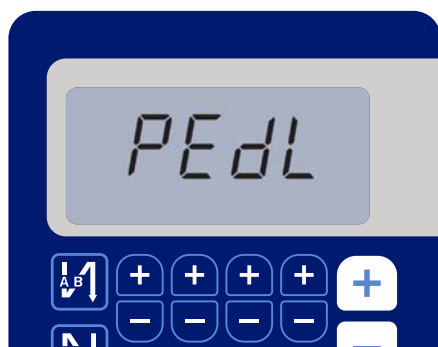

< Origin retrieval screen >

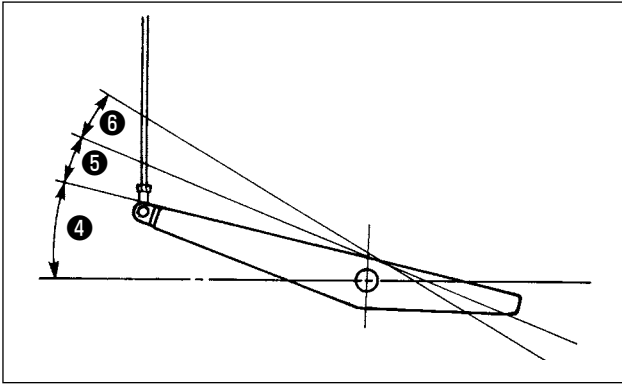

- 3) The pedal is operated in the following four steps:
- The machine runs at low sewing speed when you lightly depress the front part of the pedal. ④
  - The machine runs at high sewing speed when you further depress the front part of the pedal. ⑤ (If the automatic reverse feed stitching has been preset, the machine runs at high speed after it completes reverse feed stitching.)
  - The machine stops (with its needle up or down) when you reset the pedal to its original position.

d. The machine trims threads when you fully depress the back part of the pedal. ⑥

\* When the auto-lifer (AK device) is used, one more operating switch is provided between the sewing machine stop switch and thread trimming switch. The presser foot goes up when you lightly depress the back part of the pedal ⑤, and if you further depress the back part ⑥, the thread trimmer is actuated.

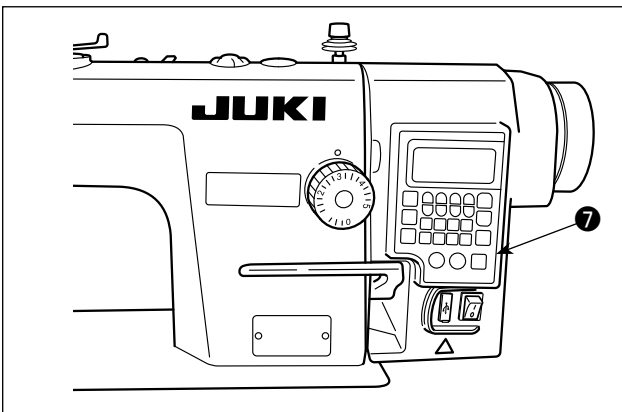

- 4) Reverse feed stitching at the beginning of sewing, reverse feed stitching at the end of sewing and various sewing patterns can be set on built-in panel ⑦ of the machine head.

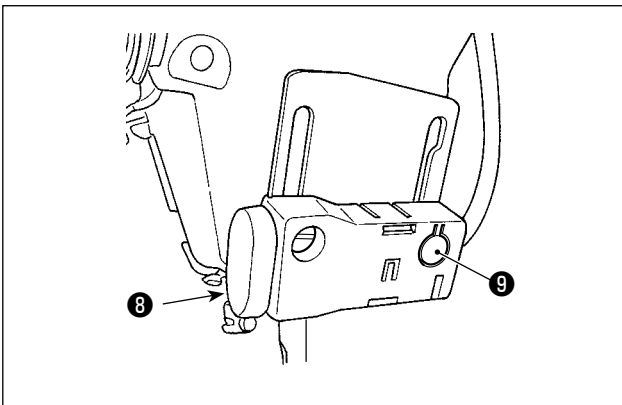

- 5) When one-touch type reverse feed switch ⑧ is pressed, the sewing machine performs reverse feed stitching. Intensity adjustment and turn-off of the light is carried out by pressing switch ⑨. Every time the switch is pressed, the light is adjusted in intensity in five steps and is turned off in turn.

**[Change of intensity]**

1 ⇒ ..... 4 ⇒ 5 ⇒ 6

Bright ⇒ ..... Dim ⇒ Off ⇒ Bright

In this way, every time the switch ⑨ is pressed, the hand lamp status is changed in repetition.

- 6) After the completion of sewing, check to make sure that the sewing machine has stopped. Then, press power switch ① or ② (or turn EU-type power switch ③) to turn it OFF.









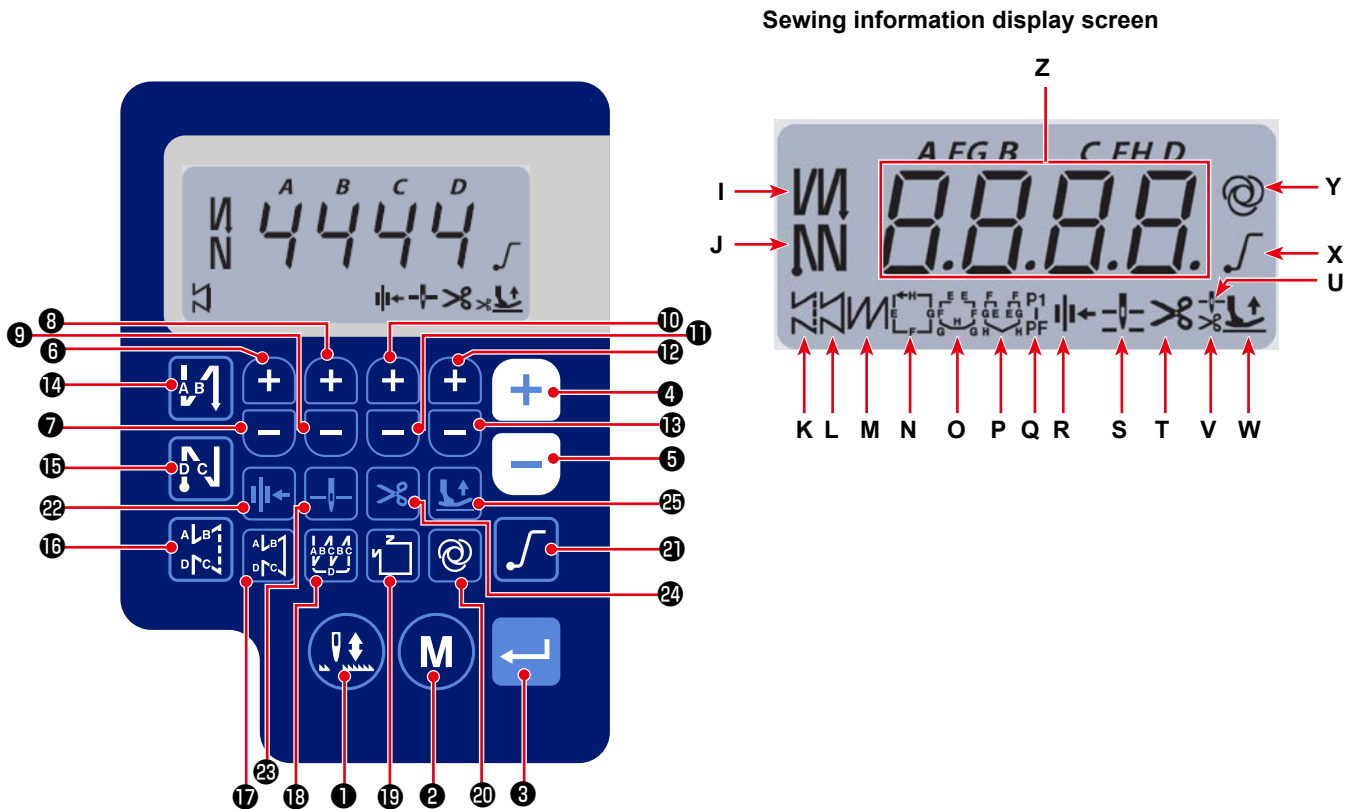









**In the case the machine is not used for a long time, remove the power plug from the plug receptacle.**

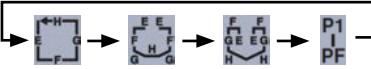

## 2. Operation panel built in the machine head



Key No.	Screen display		How long the key must be pressed	Function
①	-		Short time	This key is used to carry out needle up / down correction stitching.
②	-		Short time	Used to change over the operation mode to the function setting mode
③	-		Short time	This key is used to confirm the setting you have changed.
④	Z		Short time	Used to increase the maximum sewing speed
			Long time	Continuous input is possible (by keeping the key held pressed for three seconds or more)
⑤	Z		Short time	Used to decrease the maximum sewing speed
			Long time	Continuous input is possible (by keeping the key held pressed for three seconds or more)
⑥	Z		Short time	This key is used to add one stitch to the number of reverse feed stitches at the beginning and end of sewing (process A).
			Long time	Continuous input is possible
⑦	Z		Short time	This key is used to subtract one stitch from the number of reverse feed stitches at the beginning and end of sewing (process A).
			Long time	Continuous input is possible
⑧	Z		Short time	This key is used to add one stitch to the number of reverse feed stitches at the beginning and end of sewing (process B).
			Long time	Continuous input is possible

Key No.	Screen display		How long the key must be pressed	Function
9	Z		Short time	This key is used to subtract one stitch from the number of reverse feed stitches at the beginning and end of sewing (process B).
			Long time	Continuous input is possible
10	Z		Short time	This key is used to add one stitch to the number of reverse feed stitches at the beginning and end of sewing (process C).
			Long time	Continuous input is possible
11	Z		Short time	This key is used to subtract one stitch from the number of reverse feed stitches at the beginning and end of sewing (process C).
			Long time	Continuous input is possible
12	Z		Short time	This key is used to add one stitch to the number of reverse feed stitches at the beginning and end of sewing (process D).
			Long time	Continuous input is possible
13	Z		Short time	This key is used to subtract one stitch from the number of reverse feed stitches at the beginning and end of sewing (process D).
			Long time	Continuous input is possible
14	I		Short time	Used to changing over the automatic reverse feed stitching at the beginning of sewing to: Reverse feed stitching / Double reverse feed stitching / Disable
15	J		Short time	Used to change over the automatic reverse feed stitching at the end of sewing to: Reverse feed stitching / Double reverse feed stitching / Disable
16	K		Short time	Used to set the type of stitching to free stitching
17	L		Short time	This key is used to set the sewing mode to the constant-dimension sewing (straight line).
18	M		Short time	Used to set the type of stitching to overlapped stitching
19	N - Q		Short time	Used to change over the constant-dimension stitching pattern 
20	Y		Short time	Used to change over the one-shot operation between enable / disable
			Long time	Initialization screen for the memory switches can be displayed by pressing this key.
21	X		Short time	Used to change over the soft-start function between enable and disable
22	R		Short time	This key is used to change over the thread presser function between enable / disable.
23	S		Short time	This key is used to change over the stop position of the needle bar when the sewing machine stops between upper and lower positions.
24	T		Short time	This key is used to change over the thread trimming function between enable / disable.
25	U, V, W		Short time	This key is used to change over the presser foot lifting status among four different states: Presser foot automatically goes up after the presser bar goes up / Presser foot automatically goes up after thread trimming / Presser foot automatically goes up both after the presser foot goes up and the thread trimming is performed / Presser foot does not automatically go up.

### 3. Operating procedure of the sewing pattern

#### (1) Reverse feed stitching pattern

Reverse feed stitching at sewing start and reverse feed stitching at sewing end can be separately programmed.

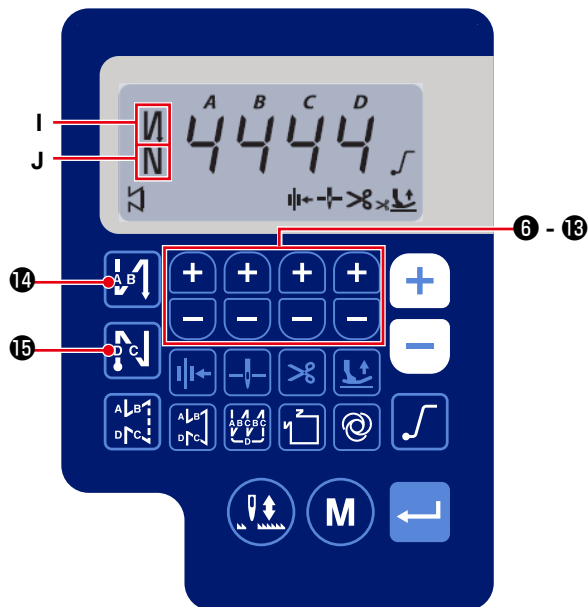

#### [Setting procedure of the reverse feed stitching]

1) The reverse feed stitching pattern at the beginning of sewing can be changed over to "enable / double reverse feed stitching / disable" by pressing





14 .

The reverse feed stitching pattern at the end of sewing can be changed over to "enable / double reverse feed stitching / disable" by pressing



15 . The current setting state of the reverse feed stitching is displayed on the display sections I and J.

2) Change the number of stitches to be sewn in target process (A, B, C, D) with   6 to 13 .



The number which exceeds 9 is indicated as follows:

A = 10, b = 11, c = 12, d = 13, E = 14, and F = 15.

## (2) Overlapped stitching pattern

Overlapped stitching pattern can be programmed.

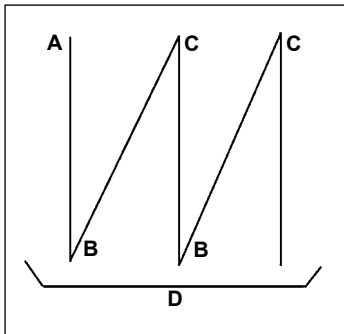

A : Number of stitches of normal stitching setting : 0 to 15 stitches

B : Number of stitches of reverse stitching setting : 0 to 15 stitches

C : Number of stitches of normal stitching setting : 0 to 15 stitches

D : Number of times of repetition : 0 to 15 times



1. When process D is set to 5 times, the sewing is repeated as A

→ B → C → B → C.

2. The number which exceeds 9 is indicated as follows:

A = 10, b = 11, c = 12, d = 13, E = 14, and F = 15.

### [Setting procedure of the overlapped stitching]

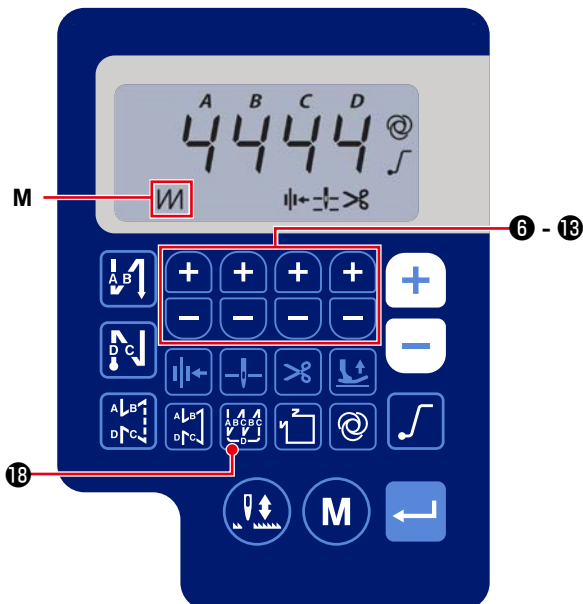

1) Press  **18** to enable the overlapped stitching pattern.

When the overlapped stitching pattern is enabled,  is displayed in the display section **M**.

2) Change the number of stitches and the number of times for the target process (A, B, C, D) with 

 **6** to **13**.



### (3) Constant-dimension stitching pattern

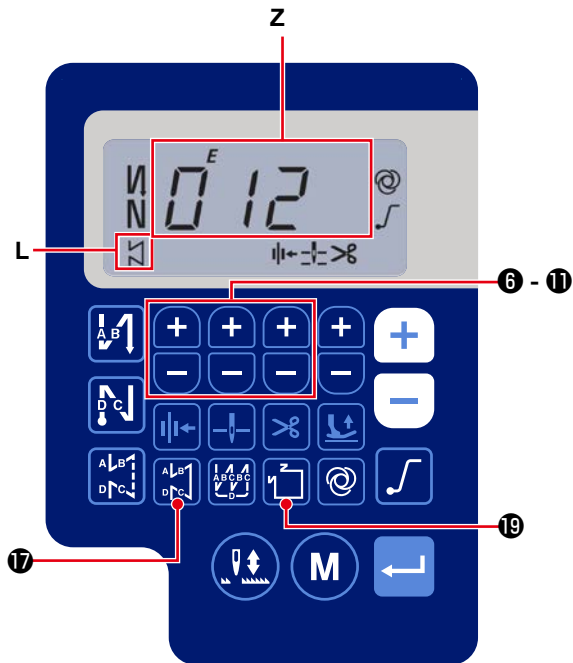

The constant-dimension stitching pattern can be set.

#### [How to set the constant-dimension stitching]

##### \* Straight stitching



1) Press  17 to enable the constant-dimension sewing pattern (straight stitch).  
When the constant-dimension sewing pattern is enabled,  is displayed on the display portion L. Immediately after the constant-dimension stitching is enabled, the numbers of reverse feed stitching processes (A, B, C and D) are displayed on the display section Z.

2) When  3 is pressed, the content shown on display section Z is changed over to the number of stitches for the constant-dimension stitching. The number of stitches (0 to 999) for the constant-dimension stitching can be selected by pressing   6~11.

\* Others

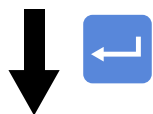
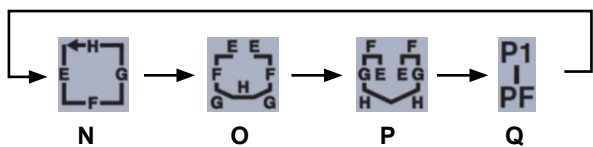

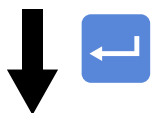
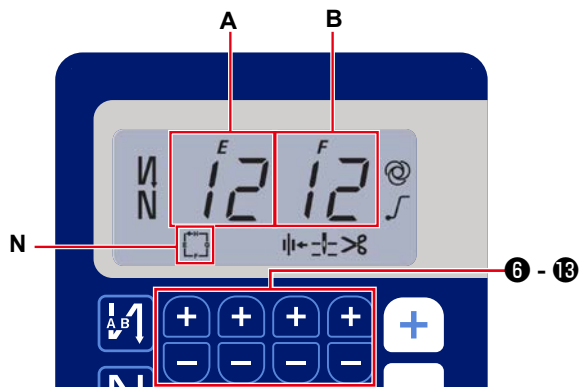

[E/F process]



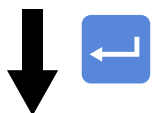
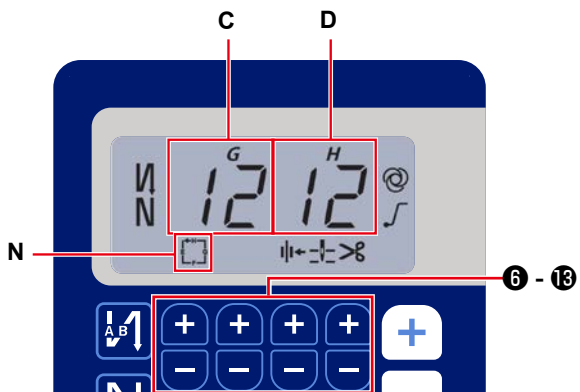



[G/H process]





The screen is shifted to the sewing information display screen

1) Enable / disable of the sewing pattern can be changed over by pressing  19. Every time  19 is pressed, the selected pattern is enabled and the valid patterns are displayed on display portion N to Q. Immediately after one of the stitching patterns is enabled, the numbers of reverse feed stitching processes (A, B, C and D) are displayed on the display section Z.

2) When switch  3 is pressed, the display section A and B changes its display to the number of stitches for the constant-dimension stitching process (EF) is displayed. The number of stitches for the process (EF) can be set by pressing   6~13.

3) Then, the content shown on display sections C and D are changed over to the number of stitches for the constant-dimension stitching process (GH) by pressing switch  3.

The number of stitches (0 to 99) for the process (GH) can be set by pressing   6~13.

4) When switch  3 is pressed, the content shown on display section Z is changed over to the numbers of stitches for the reverse feed stitching processes (A, B, C and D).

#### (4) Polygonal-shape stitching pattern

A polygonal-shape stitching pattern can be set.

##### [How to set a polygonal-shape stitching pattern]

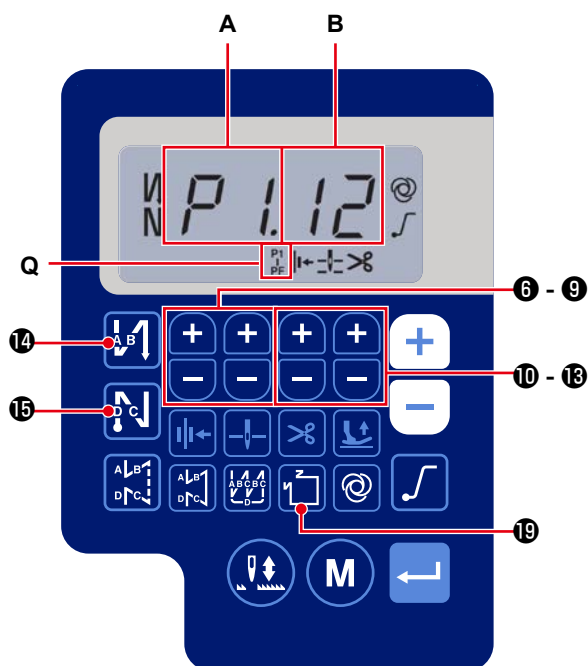

1) Press 19 to enable the polygonal shape stitching.

When the polygonal shape stitching is enabled, is displayed on display portion Q.

The number of seams (P1 - PF) can be set by pressing 6 to 9 .

**The number which exceeds 9 is indicated as follows:**  
 A = 10, b = 11, c = 12, d = 13, E = 14, and F = 15.

The number of stitches (00 - 99) can be set by pressing 10 to 13 .

##### [Number of seams / number of stitches]

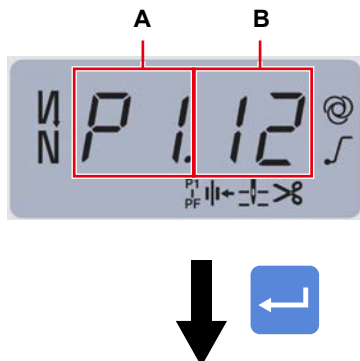

The screen is shifted to the sewing information display screen

Example) Select the number of seams (A) P1. Set the number of stitches (B) (1- 99).

Similarly, set the number of stitches (1 - 99) for the number of seams respectively in the order of P2, P3 and P4.

Select the number of seams P5. Set the "number of stitches to 0 (zero)".

- \* The "number of stitches = 0 (zero)" means termination of the polygonal shape stitching. After that, four-thread polygonal shape stitching is carried out.
- \* For the initial setting, the number of steps is set to four, and the number of stitches for each step is set to 12 (stitches).

After the setting, confirm the data you have entered

with 3 .

## 4. Setting of functions

Functions can be selected and specified.

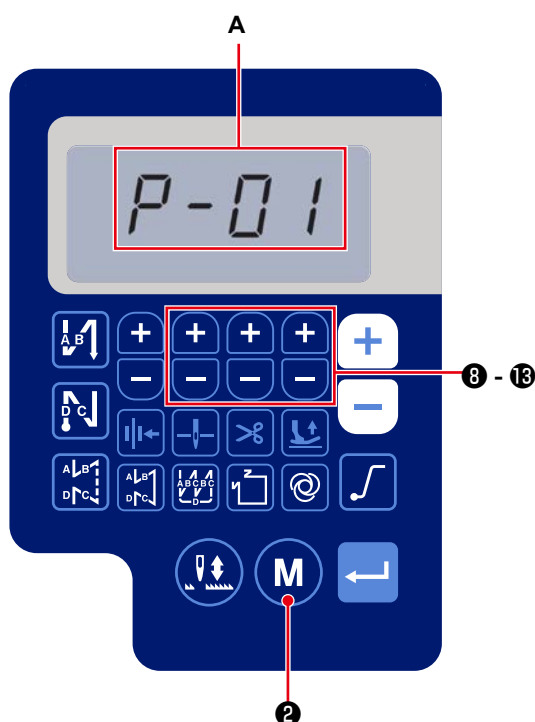

1) Press **M** ② .

The content on display section **A** is changed over to display function setting number (P-\*\*).

(The display item which was previously changed is displayed unless the power has not been turned off after the previous change.)

\* If the screen display does not change, re-carry out operation described in step 1).

**Caution**  
Be sure to re-turn ON the power switch when ten or more seconds have passed after turning it OFF. If the power switch is returned ON immediately after turning it OFF, the sewing machine may fail to operate normally. In such a case, be sure to turn ON the power switch again properly.

2) To change the function setting number press **+** **-** ⑧ to ⑬ and change it to a desired one.

3) After having changed the function setting number to a desired one, press switch **←** ③ to display the set value of the selected function setting No.

4) Press **+** **-** ⑧ to ⑬ change the set value.

5) Press switch **←** ③ to confirm the set value.



Screen returns to the previous screen.



[Parameter number]

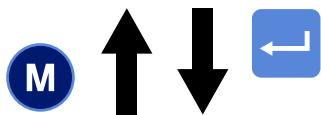
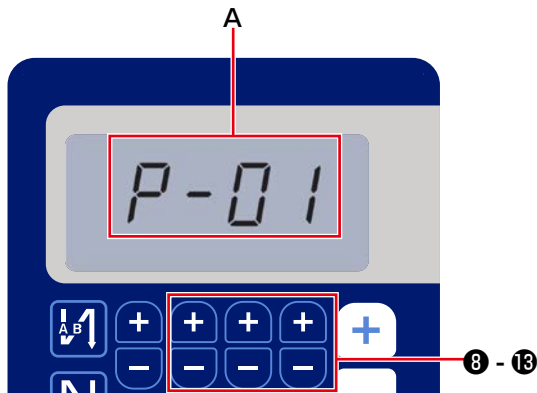

[Parameter data]

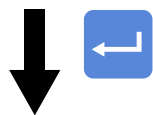
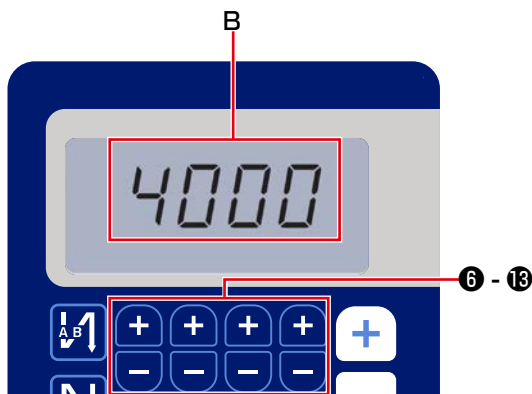

Screen returns to the previous screen.

Example) To change the setting No. P-01 "the maximum number of revolutions":

Press **M** ② to change over to the setting number display.

Press **+** **-** ⑧ to ⑬ to select setting number P-01.

Press switch **←** ③ to confirm the number (A).

If **M** ② is pressed before confirming the data, the operation being carried out will be cancelled and the screen will return to the previous screen.

The current set value (maximum number of revolutions) of function setting number P-01 is displayed. Change the maximum number of revolutions with **+** **-** ⑥ to ⑬ and confirm the set value.

Then, confirm the setting with switch **←** ③ (B).

If **M** ② is pressed before confirming the data, the operation being carried out will be cancelled and the screen will return to the [Parameter number] screen.

## 5. Digital types operation

### (1) Comparison Table of LCD Display Fonts and Actual Fonts

Arabic Numerals :

Actual	0	1	2	3	4	5	6	7	8	9
Display	<i>0</i>	<i>1</i>	<i>2</i>	<i>3</i>	<i>4</i>	<i>5</i>	<i>6</i>	<i>7</i>	<i>8</i>	<i>9</i>

### (2) Digital Display on the Key Board

English Alphabet

Actual	A	B	C	D	E	F	G	H	I	J	K	L	M
Display	<i>A</i>	<i>b</i>	<i>C</i>	<i>d</i>	<i>E</i>	<i>F</i>	<i>G</i>	<i>H</i>	<i>i</i>	<i>J</i>	<i>K</i>	<i>L</i>	<i>M</i>
Actual	N	O	P	Q	R	S	T	U	V	W	X	Y	Z
Display	<i>n</i>	<i>o</i>	<i>P</i>	<i>q</i>	<i>r</i>	<i>S</i>	<i>T</i>	<i>U</i>	<i>v</i>	<i>W</i>	<i>X</i>	<i>Y</i>	<i>Z</i>

## 6. Function setting list

No.	Item	Description	Level	Setting range	Default	
					AS-7	AH-7
P01	Maximum sewing speed	The maximum sewing speed reached by fully depressing the pedal is set with this function setting item. The maximum sewing speed can be changed within the sewing speed range specified for [P68 Maximum sewing speed]. * The maximum sewing speed can be changed with the switch on the operation panel.	U	100-[P68] (sti/min)	4000	3500
P04	Reverse feed stitching speed at the beginning of sewing	The sewing speed to be used during the reverse feed stitching at the beginning of sewing is set with this function setting item.	U	100-3000 (sti/min)	1900	1900
P05	Reverse feed stitching speed at the end of sewing	The sewing speed to be used during the reverse feed stitching at the end of sewing is set with this function setting item.	U	100-3000 (sti/min)	1900	1900
P06	Overlapped stitching speed	The sewing speed to be used during the overlapped stitching is set with this function setting item. * The overlapped stitching speed can be changed with the switch on the operation panel.	U	100-3000 (sti/min)	1900	1900
P07	Sewing speed for soft start	The sewing speed for soft start at the beginning of sewing is set with this function setting item.	U	100-1500 (sti/min)	800	800
P08	Soft start function	The number of stitches to be sewn with the soft-start function at the beginning of sewing is set with this function setting item. 0 - 99: The number of stitches to be sewn with the soft-start function	U	0-99 (Stitches)	1	1
P09	Sewing speed of the constant dimension sewing	This parameter is used to set the sewing speed to be employed when the constant dimension sewing is performed. * The sewing speed can be changed with the switch on the operation panel.	U	200-[P68] (sti/min)	4000	3500
P10	Setting of the reverse feed stitching at the end of constant dimension sewing	This parameter is used to set whether or not the reverse feed stitching is automatically performed at the end of constant dimension sewing. ON: Reverse feed stitching is automatically performed at the end of sewing OFF: Sewing machine stops sewing before starting reverse feed stitching at the end of sewing. It performs reverse feed stitching when the front part of pedal is depressed.	U	ON/OFF	ON	ON
P11	Selection of operation of BSW	This parameter is used to select the operation of the BSW. 0: Reverse feed stitching at the midpoint of sewing 1: Needle up / down correction switch			0	0
P12	Changeover of the reverse feed stitching at the start of sewing between Auto / Manual	The sewing speed for the reverse feed stitching at the beginning of sewing is set with this function setting item. 0: The reverse feed stitching is performed by manually operating the pedal. 1: The reverse feed stitching is performed at the sewing speed set with [P04 Reverse feed stitching speed at the beginning of sewing].	U	0-1	1	1
P13	Function of stop immediately after the reverse feed stitching at the beginning of sewing	Operation to be carried out at the end of the reverse feed stitching at the beginning of sewing is selected with this function setting item. CON: The sewing machine does not stop temporarily after completion of the reverse feed stitching at the beginning of sewing STP: The sewing machine stops temporarily after completion of the reverse feed stitching at the beginning of sewing	U	CON/STP	CON	CON
P15	Changeover of the needle up/down correction function	The function of needle up/down correction switch is changed over with this function setting item. 0: Needle up/down correction 1: One stitch correction 2: Continuous half stitch 3: Continuous one stitch	U	0-3	0	0
P18	Correction of solenoid-on timing for the reverse feed stitching at the beginning of sewing	Stitch alignment can be carried out by changing the timing of actuating the reverse-feed stitching solenoid at the time of reverse feed stitching at the beginning of sewing. When the set value for this parameter is increased, the length of stitch at the end of A process is increased and the length of stitch at the beginning of B process is decreased.	U	0-200	132	120
P19	Correction of solenoid-off timing for the reverse feed stitching at the beginning of sewing	Stitch alignment can be carried out by changing the timing of releasing the reverse-feed stitching solenoid at the time of reverse feed stitching at the beginning of sewing. When the set value for this parameter is increased, the length of stitch at the beginning of B process is increased.	U	0-200	148	160
P25	Correction of solenoid-on timing for the reverse feed stitching at the end of sewing	Stitch alignment can be carried out by changing the timing of actuating the reverse-feed stitching solenoid at the time of reverse feed stitching at the end of sewing. When the set value for this parameter is increased, the length of stitch at the beginning of C process is increased.	U	0-200	100	112
P26	Correction of solenoid-off timing for the reverse feed stitching at the end of sewing	Stitch alignment can be carried out by changing the timing of releasing the reverse-feed stitching solenoid at the time of reverse feed stitching at the end of sewing. When the set value for this parameter is increased, the length of stitch at the end of C process is decreased and the length of stitch at the beginning of D process is increased.	U	0-200	151	158

No.	Item	Description	Level	Setting range	Default	
					AS-7	AH-7
P32	Correction of solenoid-on timing for the overlapped stitching	Stitch alignment can be carried out by changing the timing of actuating the reverse feed stitching solenoid at the time of overlapped stitching. When the set value for this parameter is increased, the length of stitch at the end of A (C) process is increased and the length of stitch at the beginning of B process is decreased.	U	0-200	125	125
P33	Correction of solenoid-off timing for the overlapped stitching	Stitch alignment can be carried out by changing the timing of releasing the reverse-feed stitching solenoid at the time of overlapped stitching. When the set value for this parameter is increased, the length of stitch at the end of B process is increased and the length of stitch at the beginning of C process is decreased.	U	0-200	160	160
P37	First current value (ON duty) of thread clamp	The first current value (ON duty) for the thread clamp is set with this function setting item. * Refer to the "explanation of the thread clamp solenoid operation" in the Engineer's Manual for details.	U	0-100	40	50
P41	Thread trimming counter	This parameter is used to display the current value of the thread trimming counter.				
P46	Setting of the function of reverse revolution to lift the needle	This function rotates the main shaft in the reverse direction of sewing to bring the needle bar to the highest position. ON: Reverse-revolution operation is in the ON state OFF: Reverse-revolution operation is in the OFF state	U	ON/OFF	OFF	OFF
P48	Sewing speed at a low speed	The minimum sewing speed of the sewing machine by operating the pedal is set with this function setting item.	U	100-500 (sti/min)	200	200
P49	Sewing speed for thread trimming	Sewing speed to be used when performing thread trimming is set with this function setting item.	U	100-250 (sti/min)	210	210
P53	Setting of operation of the presser foot when the back part of pedal is depressed	The operation of the presser foot when the back part of pedal is depressed is set with this function setting item. 0: Presser foot does not operate even when the back part of pedal is depressed. 1: When the back part of pedal is depressed, the presser foot goes up to its upper position.	U	0-1	1	1
P57	Work clamp lifting operation time	This parameter is used to set the time at which the work clamp lifting solenoid is turned ON.	U	10-120 (sec)	60	60
P68	Maximum sewing speed	The maximum sewing speed is set with this function setting item. (The MAX value differs with the type of machine head. S: 5000; H: 4500)	S	100-MAX (sti/min)	4000	3500
P70	Machine head selection (Initialization of data)	Machine head type is selected with this function setting item. 2: DDL-7000AS-7 3: DDL-7000AH-7 * When you select the corresponding machine head and press the enter switch, all existing data are initialized to the initial values for the machine head you have selected.	S	2-3	2	3
P77	Back-tack solenoid ON timing at the end of sewing	The BT solenoid ON timing at the end of sewing is set with this function setting item. * This parameter applies only to the free stitching.	U	50-330	150	200
P78	Thread clamp ON angle	ON-angle of the thread clamp is set with this function setting item.	U	0-359 (°)	190	190
P79	Thread clamp OFF angle	OFF-angle of the thread clamp is set with this function setting item.	U	0-359 (°)	300	300
P113	Bobbin counter	The largest value that the bobbin counter can count is set with this function setting item.	U	0-9999 (10 stitches)	0	0
P116	Function of prohibiting the correction operation after turning the handwheel by hand	This item is used to set the compensating stitch function activated by turning the pulley by hand after the completion of constant-dimension sewing (etc.) and polygonal-shape stitching. 0: Correction sewing function is disabled 1: Correction sewing function is enabled * This parameter is enabled in the case "P11 Selection of operation of BSW" is set to "1: Needle up/down correction switch".	U	0-1	0	0
P117	Thread trimming operation after turning the handwheel by hand	The thread trimming operation after turning the pulley by hand to move the sewing machine from the upper and lower positions is set with this function setting item. 0: Thread trimming operation is not carried out after turning the pulley by hand. 1: Thread trimming operation is carried out after turning the pulley by hand	U	0-1	1	1
P118	Setting of the needle up/down switch operation after thread trimming	The operation of the needle up/down switch after thread trimming is set with this function setting item. 0: Needle up/down operation is carried out 1: One-stitch operation is carried out	U	0-1	0	0
P136	Selection of the presser foot operation when the power is turned ON	Operation of the presser foot when the power is turned ON is selected with this function setting item. 0: The presser foot does not operate (It operates when the back part of the pedal is depressed.) 1: The presser foot goes up after automatically retrieving the origin 2: The presser foot comes down after automatically retrieving the origin	U	0-2	0	0

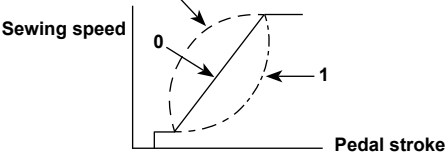
No.	Item	Description	Level	Setting range	Default	
					AS-7	AH-7
P138	Function of pedal curve selection	Pedal curve is selected. (Improving pedal inching operation) 	U	0-2	0	0
P139	Function of reverse feed stitching on the way	The function activated when the reverse feed stitching on the way switch is pressed is selected with this function setting item. 0: Normal back-tack function 1: Function of reverse feed stitching on the way is enabled (In the case the function for reverse feed stitching at midpoint of sewing is enabled, P142 function can be used.)	U	0-1	0	0
P140	Number of stitches of reverse feed stitching on the way	The number of stitches of reverse feed stitching on the way is set with this function setting item.	U	1-19	4	4
P141	Condition to be satisfied to enable the reverse feed stitching on the way while the sewing machine is at rest	The condition to be satisfied to enable the reverse feed stitching switch while the sewing machine is at rest is set with this function setting item. 0: Disabled while the sewing machine is at rest 1: Enabled while the sewing machine is at rest	U	0-1	0	0
P142	Thread trimming function after performing reverse feed stitching on the way	Automatic thread trimming operation after performing the reverse feed stitching on the way is set with this function setting item. 0: Automatic thread trimming is not performed after the completion of reverse feed stitching on the way 1: Automatic thread trimming is performed after the completion of reverse feed stitching on the way	U	0-1	0	0
P143	Sewing speed for reverse feed stitching on the way	Sewing speed during the reverse feed stitching on the way is set with this function setting item.	U	200-3000 (sti/min)	1900	1900
P163	Ending angle of soft start for the thread clamp	The ending angle of the soft start for the thread clamp is set with this function setting item. * Refer to the explanation of operation of the thread clamp solenoid in the Engineer's Manual for details.	U	0-720	340	340
P166	1st electric current time for thread clamp	Period of time during which the 1st electric current is fed applied to the thread clamp is set with this function setting item. * Refer to the explanation of operation of the thread clamp solenoid in the Engineer's Manual for details.	U	1-990	7	7
P167	2nd electric current value for thread clamp (ON duty)	"ON duty" is set in order to determine the 2nd electric current value of the thread clamp * Refer to the explanation of operation of the thread clamp solenoid in the Engineer's Manual for details.	U	0-100	69	69
J10	Setting of brightness of the backlight	Brightness of the backlight is set with this function setting item.	U	1-3	3	3
J14	Password	If the password is set to a number other than "0000", the password entry screen will be displayed before displaying the function setting screen by pressing the M switch. * This data is not initialized with the parameter P70.	S	0000-9999	0000	0000
N01	Main software version	Main software version is displayed with this function setting item.	U			
N02	Panel software version	Panel software version is displayed with this function setting item.	U			

## 7. Details of setting of the main functions



1. In following parameter operation **+** **-** key, it will display corresponding speed value.
2. In following function, after value changed, press **←** key to save the value, otherwise they will lost after turning power off.

### ① How to set [Maximum Sewing Speed]

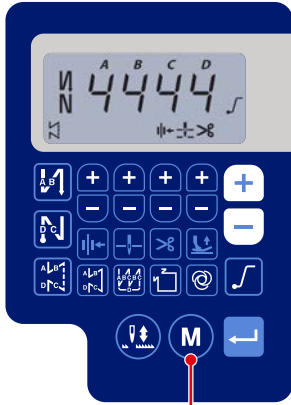

Press **M** **2** to enter user parameter.

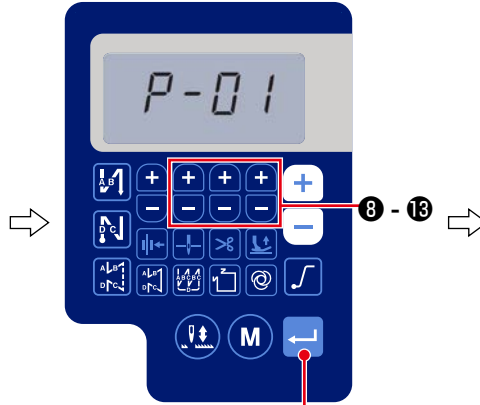

Press **+**, **-** **8** to **13** select the parameter code P01. Then, press **←** **3** to enter [Function setting data].

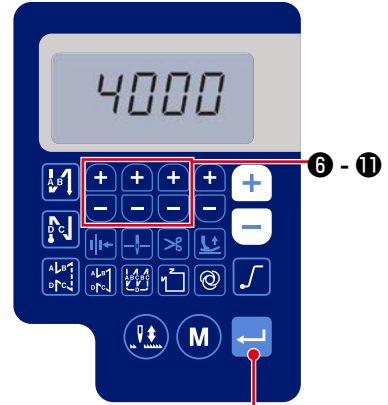

① Press **+**, **-** **6** to **11** to adjust the Maximum Sewing Speed  
② After adjustment press **←** **3** to save value.

### ② How to set [Start Back-Tacking Speed]

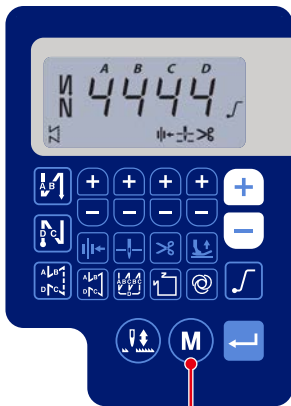

Press **M** **2** to enter user parameter.

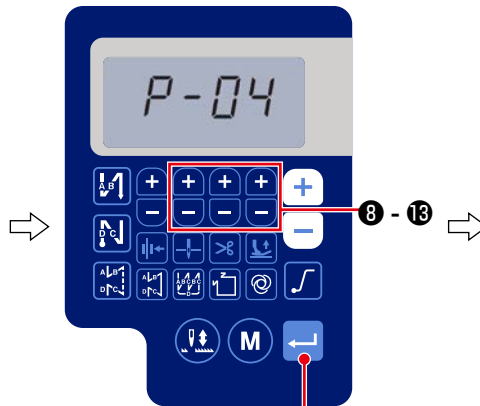

Press **+**, **-** **8** to **13** select the parameter code P04. Then, press **←** **3** to enter [Function setting data].

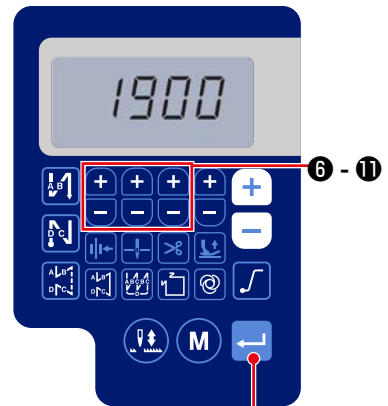

① Press **+**, **-** **6** to **11** key to adjust the Start Back-Tacking Speed  
② After adjustment press **←** **3** to save value.

### ③ How to set [End Back-Tacking Speed]

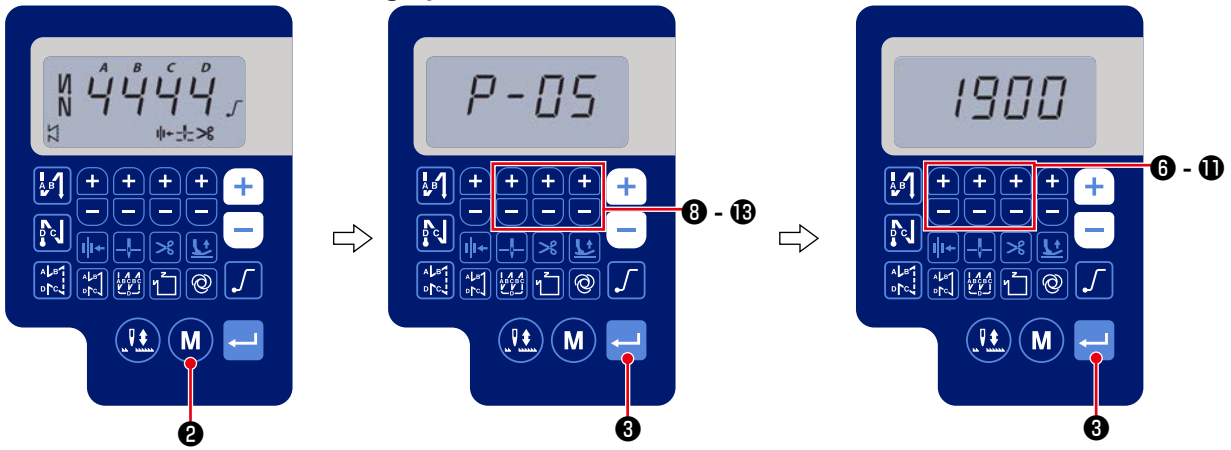

Press **M** ② to enter user parameter.

Press **+**, **-** ⑧ to ⑬ select the parameter code P05. Then, press **←** ③ to enter [Function setting data].

① Press **+**, **-** ⑥ to ⑪ to adjust the End Back-Tacking speed.  
② After adjustment press **←** ③ to save value.

### ④ How to set [Bar-Tacking Speed]

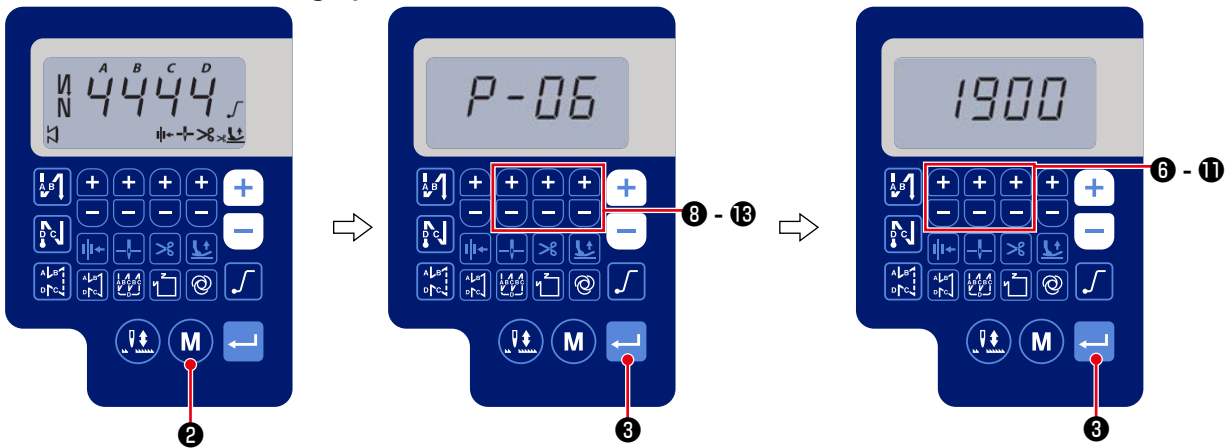

Press **M** ② to enter user parameter.

Press **+**, **-** ⑧ to ⑬ select the parameter code P06. Then, press **←** ③ to enter [Function setting data].

① Press **+**, **-** ⑥ to ⑪ to adjust the Bar-Tacking Speed.  
② After adjustment press **←** ③ to save value.

⑤ How to set [Constant-Stitch Sewing Speed]

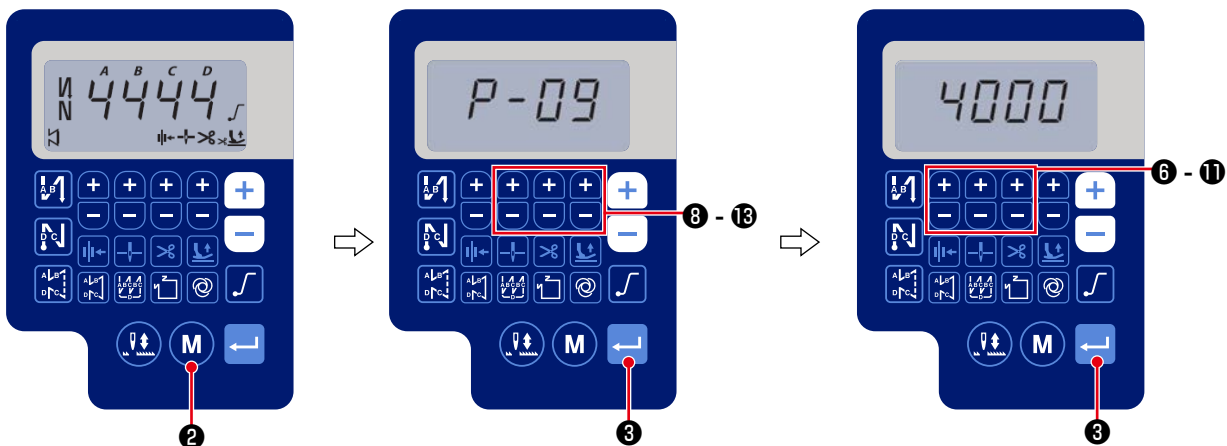

Press **M** ② to enter user parameter.

Press **+** , **-** ⑧ to ⑬ select the parameter code P09. Then, press **←** ③ to enter [Function setting data].

① Press **+** , **-** ⑥ to ⑪ to adjust the Constant-Stitch Sewing speed  
 ② After adjustment press **←** ③ to save value.



⑥ **Selection of the soft-start function (Function setting No. P08)**

The needle thread may fail to interlace with the bobbin thread at the start of sewing when the stitching pitch (stitch length) is small or a thick needle is used. To solve such problem, this function (called "soft-start") is used to limit the sewing speed, thereby assuring successful formation of the starting stitches.

**P 0 8**      0 to 99 : The number of stitches to be sewn under the soft-start mode.

The sewing speed limited by the soft-start function can be changed. **(Function setting No. P07)**

**P 0 7**      Data setting range : 100 to 1500 [sti/min] <10 sti/min>

⑦ **Changeover of the needle up/down switch function (Function setting No. P15)**

The function of the needle up/down switch is changed over with this function setting number.

**P 1 5**      0 : Needle up/down correction  
              1 : One-stitch correction  
              2 : Continuous half stitch  
              3 : Continuous one stitch

⑧ **Function of reverse feed stitching on the way (Function setting Nos. P139 to P143)**

Functions of the limit of number of stitches and thread trimming command can be added to the touch back switch on the sewing machine head.

Function setting No.139    Function of reverse feed stitching on the way is selected.

**1 3 9**      0 : OFF    Normal back-tack function  
              1 : ON     Function of reverse feed stitching on the way

Function setting No.140    Number of stitches performing reverse feed stitching is set.

**1 4 0**      Setting range : 0 to 19 stitches

Function setting No.141    Effective condition of reverse feed stitching on the way

**1 4 1**      0 : OFF    Inoperative when the sewing machine stops. (The reverse feed stitching on the way functions only while the sewing machine is in operation.)  
              1 : ON     Operative when the sewing machine stops. (The reverse feed stitching on the way functions while both the sewing machine is in operation and is at rest.)

**(Caution) Either condition is operative when the sewing machine is running.**

Function setting No.142    Thread trimming is performed when reverse feed stitching on the way is completed.

**1 4 2**      0 : OFF    Without thread trimming  
              1 : ON     Thread trimming is executed.

Function setting No.143    Set the sewing speed when the reverse feed stitching at midpoint of sewing is performed.

**1 4 3**      Setting range : 200 to 3000 [sti/min] <10 sti/min>

Application	Function setting			Output function
	No. P139	No. P141	No. P142	
①	0	0 or 1	0 or 1	It works as normal touch-back switch.
②	1	0	0	When operating touch-back switch at the time of depressing front part of the pedal, reverse feed stitching as many as the number of stitches specified by the function setting No. P140 can be performed.
③	1	1	0	When operating touch-back switch at the time of either stop of the sewing machine or depressing front part of the pedal, reverse feed stitching as many as the number of stitches specified by the function setting No. P140 can be performed.
④	1	0	1	When operating touch-back switch at the time of depressing front part of the pedal, automatic thread trimming is performed after reverse feed stitching as many as the number of stitches specified by the function setting No. P140 has been performed.
⑤	1	1	1	When operating touch-back switch at the time of either stop of the sewing machine or depressing front part of the pedal, automatic thread trimming is performed after reverse feed stitching as many as the number of stitches specified by the function setting No. P140 has been performed.

#### Actions under each setting state

- ① Used as the normal reverse feed stitching touch-back switch.
- ② Used for reinforcing seam (press sewing) of the pleats. (It works only while the sewing machine is in operation)
- ③ Used for reinforcing seam (press sewing) of the pleats. (It works either when the sewing machine stops or when the sewing machine is running.)
- ④ Used as starting switch for reverse feed stitching at the sewing end. (Used as the substitute for thread trimming by depressing back part of the pedal. It works only while the sewing machine is in operation. This is especially effective when the sewing machine used as the sewing machine for standing work.)
- ⑤ Used as starting switch for reverse feed stitching at the sewing end. (Used as the substitute for thread trimming by depressing back part of the pedal. It works either when the sewing machine stops or when the sewing machine is running. It is especially effective when the sewing machine is used as the standing-work machine.)

### ⑨ Function of pedal curve selection (Function setting No. P138)

This function can perform the selection of the curve of sewing speed of the sewing machine against the depressing amount of the pedal.

Change to this function when you feel that inching operation is hard or that pedal response is slow.

- 1 3 8 0 : Sewing speed in terms of the depressing amount of the pedal increases linearly.
- 1 : Reaction to intermediate speed in terms of the depressing amount of the pedal is delayed.
- 2 : Reaction to intermediate speed in terms of the depressing amount of the pedal is advanced.

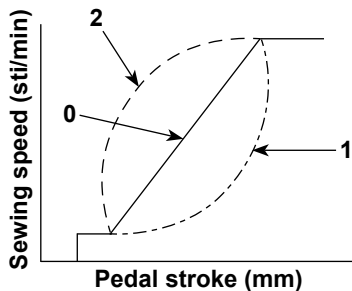

### ⑩ Selection of the presser foot operation when the power is turned ON (Function setting No. P136)

The needle bar goes up to its upper position and the presser motor carries out origin retrieval operation immediately after the power is turned ON.

- 1 3 6 0 : Neither the needle bar nor the presser motor (Operates when the back part of pedal is depressed)
- 1 : Needle bar goes up to its upper position and the presser motor automatically goes up after automatic origin retrieval.
- 2 : Needle bar automatically goes up to its upper position and the presser motor comes down after automatic origin retrieval.

### ⑪ Setting of the operation of needle up/down switch after thread trimming (Function setting No. P118)

One stitch operation can be performed only when the needle up / down compensating switch is pressed at the time of upper stop immediately after turning ON the power switch or upper stop immediately after thread trimming.

- 1 1 8 0 : Normal (Only needle up / down compensating stitching operation)
- 1 : One stitch compensating stitching operation (upper stop / upper stop) is performed only when aforementioned changeover is made.

### ⑫ Thread trimming counter (Function setting No. P41)

- P 4 1 This parameter is used to display the current value of the thread trimming counter. The sewing machine is able to perform sewing while displaying the counter value.

To reset the counter to 0 (zero), press needle up / down correction key .

## 8. Stitch balance of back-tacking for lockstitch machine

### ① How to balance stitches for [Start Back-Tacking] (Function setting Nos. P18 and P19)

Example) Step 1: Setting stitch number for Start Back-Tacking A and B = 3

Step 2: Sewing the pattern in normal speed.

Step 3: If unbalanced situation is appeared please correct it as below:

Suggestion: Select the balance stitches for Section A before selecting for B.

Start point - - -

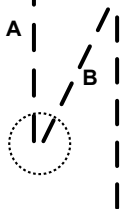

Case 1 : Longer A and shorter B

Adjustment : [P18] Decrease the set value.

A becomes shorter and B becomes longer.

Start point - - -

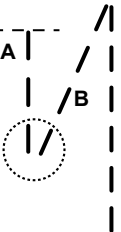

Case 2 : Shorter A and longer B

Adjustment : [P18] Increase the set value.

A becomes longer and B becomes shorter.

Start point - - -



Case 3 : Normal A and longer B

Adjustment : [P19] Decrease the set value.

B becomes shorter.

Start point - - -

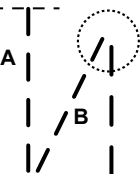

Case 4 : Normal A and shorter B

Adjustment : [P19] Increase the set value.

B becomes longer.

② How to balance stitches for [End Back-Tacking] (Function setting Nos. P25, P27 and P77)

Example) Step 1: Setting stitch number for End Back-Tacking C and D = 3

Step 2: Sewing the pattern in normal speed.

Step 3: If unbalanced situation is appeared please correct it as below:

Suggestion: Select the balance stitches for Section C before selecting for D.

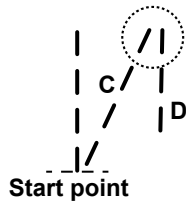

Case 1 : Longer C and shorter D  
Adjustment : [P26] Decrease the set value.  
C becomes shorter and D becomes longer.

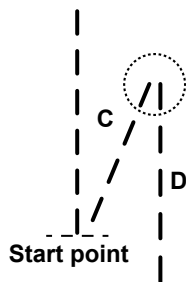

Case 2 : Shorter C and normal D  
Adjustment : [P26] Increase the set value.  
C becomes longer and D becomes shorter.

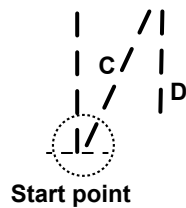

Case 3 : C is longer.  
Adjustment : [P77] Change the set value to such a value that shortens C.

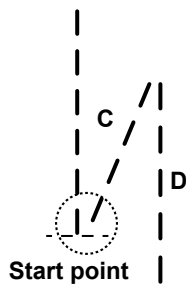

Case 4 : C is short.  
Adjustment : [P77] Increase the set value.  
C becomes longer.

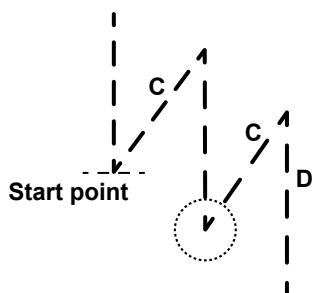

Case 5 : Normal C and longer D  
Adjustment : [P25] Decrease the set value.  
C becomes longer and D becomes shorter.

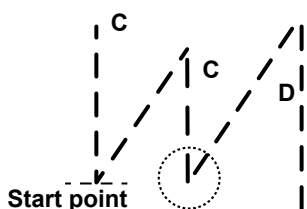

Case 6 : Normal C and shorter D  
Adjustment : [P25] Increase the set value.  
C becomes shorter and D becomes longer.

③ How to balance stitches for [Bar Tacking] (Function setting Nos. P32 and P33)

- Example) Step 1: Setting stitch number for Bar-Tacking A = B = 4 and turns of Bar-Tacking D = 4  
 Step 2: Sewing the pattern in normal speed.  
 Step 3: If unbalanced situation is appeared please correct it as below:

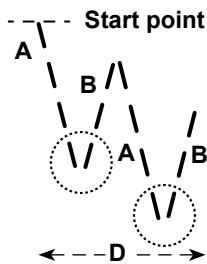

Case 1 : Longer A and shorter B  
 Adjustment : [P32] Decrease the set value.  
 A becomes shorter and B becomes longer.

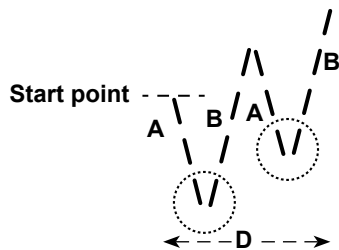

Case 2 : Shorter A and normal B  
 Adjustment : [P32] Increase the set value.  
 A becomes longer and B becomes shorter.

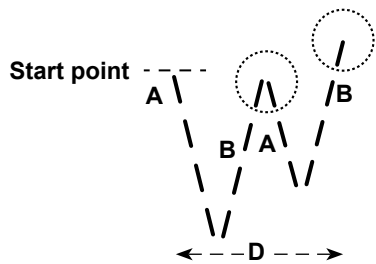

Case 3 : Normal A and longer B  
 Adjustment : [P33] Decrease the set value.  
 B becomes shorter.

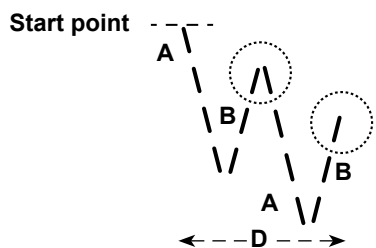

Case 4 : Normal A and shorter B  
 Adjustment : [P33] Increase the set value.  
 B becomes longer.

## 9. How to set the machine head and to initialize data (the factory-set state at the time of shipment)

\* This item has been factory-adjusted at the time of shipment. Carry out the machine head setting procedure in the case the control box is replaced, or in any case where it is necessary.

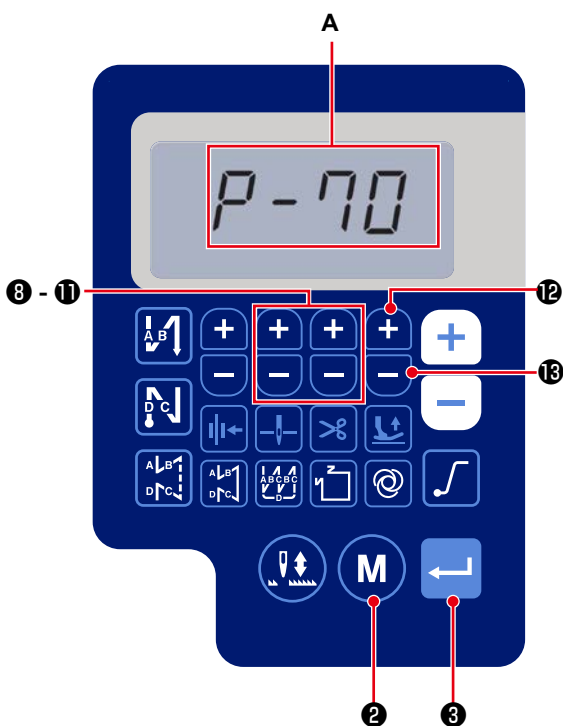

- 1) Turn the power ON while keeping **M** ② or **←** ③, or **M** ② and **←** ③ held pressed simultaneously. (This function is activated under the service level.)
- 2) Press **+** ⑫ **-** ⑬ ⑧ to ⑩ to select the function setting No. 70 (A).
- 3) Confirm the data with **←** ③.
- 4) Press **+** ⑫ and **-** ⑬ to select the corresponding machine head.

Set value = 2: DDL-7000AS-7

Set value = 3: DDL-7000AH-7

5) Data is initialized by pressing **←** ③. Then, the sewing machine returns to the normal sewing state.

\* If you want to initialize the data, change the setting of the type of machine head to a different type, then select the desired type of machine head.

Example) In the case the selected type of machine head is "2":

P70 Change the selected type of machine head from "2" to "3". Press **←** ③.

Change the selected type of machine head again from "3" to "2". Press **←** ③.

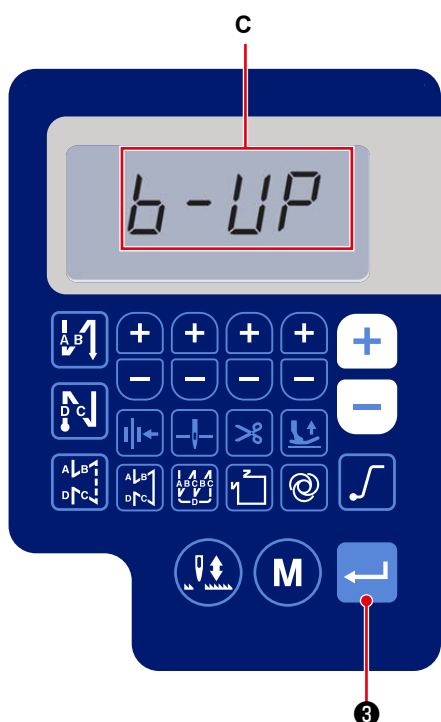
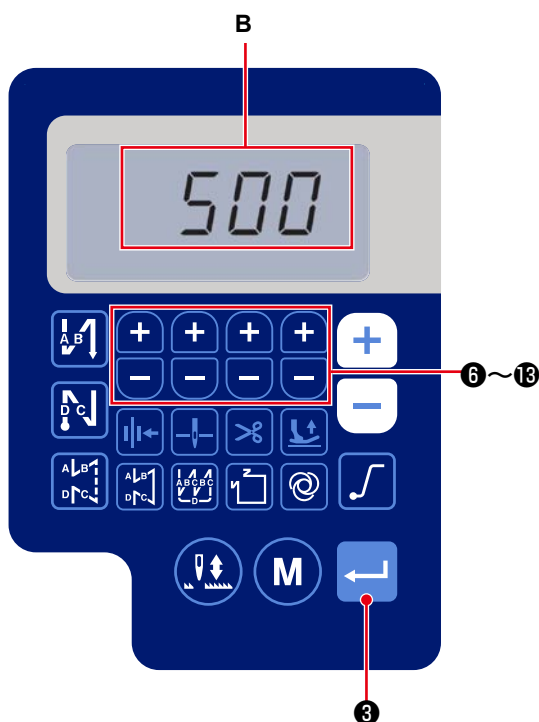
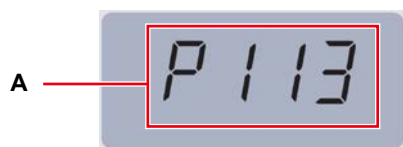

## 10. How to use the bobbin counter

In the case the number of stitches that can be counted on the bobbin counter (Function setting number P113) is set to "x10", the bobbin count complete screen is displayed when the bobbin counter reaches the set value to notify the operator that the bobbin has to be changed.



- 1) Call function setting No. P113 referring to **"III-4. Setting of functions" p.33.**

Confirm the data with  **3**.

- 2) Press   **6** to **13** to set the bobbin counter value (**B**).

When the bobbin counter reaches the "bobbin counter value x 10", the bobbin count complete screen is displayed.

- 3) Press  **3** to determine the set value and return the sewing machine to the normal sewing state.

- 4) Carry out sewing. When the bobbin counter value becomes "0" (zero), the count complete screen is displayed. (**C**)

When you press  **3**, the current value on the bobbin counter returns to the value set with "function setting No. P113 Bobbin counter" and the sewing machine returns to the normal sewing state.



## 11. Initialization of function setting data

The function setting data that are changed arbitrarily by the customer can be stored in memory. The current function setting data can be restored to the aforementioned data.

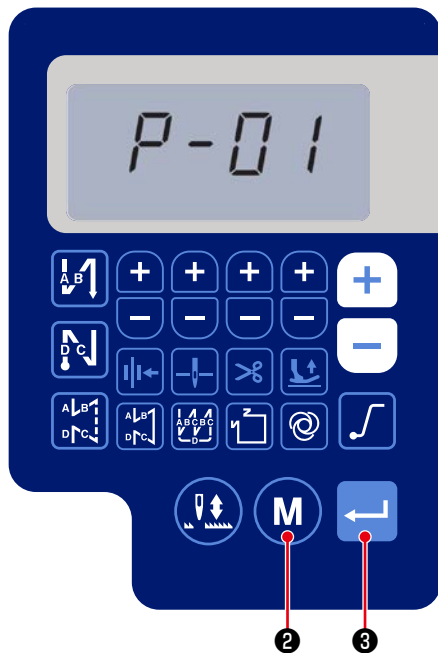

1) Press **M** ② under the normal sewing state to display the function setting screen.

Refer to "III-4. Setting of functions" p.33.

Confirm the data with  ③.

\* You may select any function setting number.



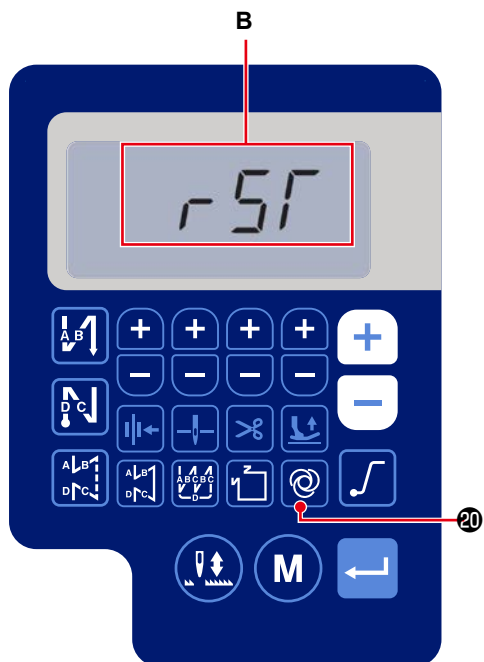

2) On the screen that you can operate the function setting data, keep  ② held pressed for three seconds. Then the function setting data being displayed is saved and the "SAVE" screen (A) is displayed for a moment.

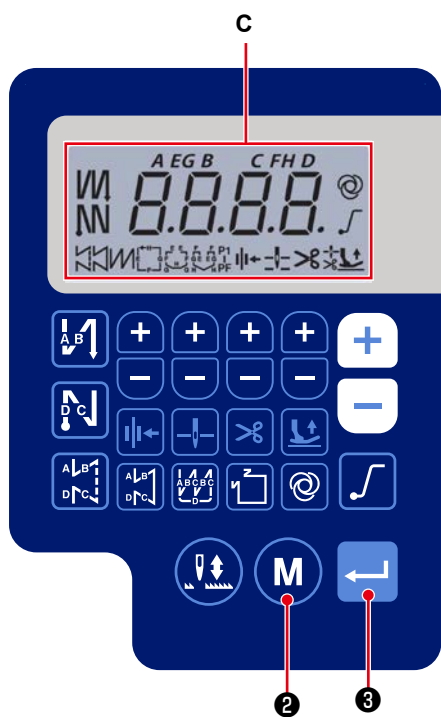

3) When  20 is held pressed for three seconds under the normal sewing state, the data initialization screen is displayed.



4) When  3 is pressed, all of the function setting data saved in the steps of procedure 1) and 2) are initialized and the entire screen display of LCD (C) is displayed for a moment. Then, the sewing machine returns to the normal sewing state.

5) Data initialization is cancelled by pressing  M 2. Then, the sewing machine returns to the normal sewing state.

## 12. Password lock

The operation of function setting can be locked with a password by pressing **M** **2**.

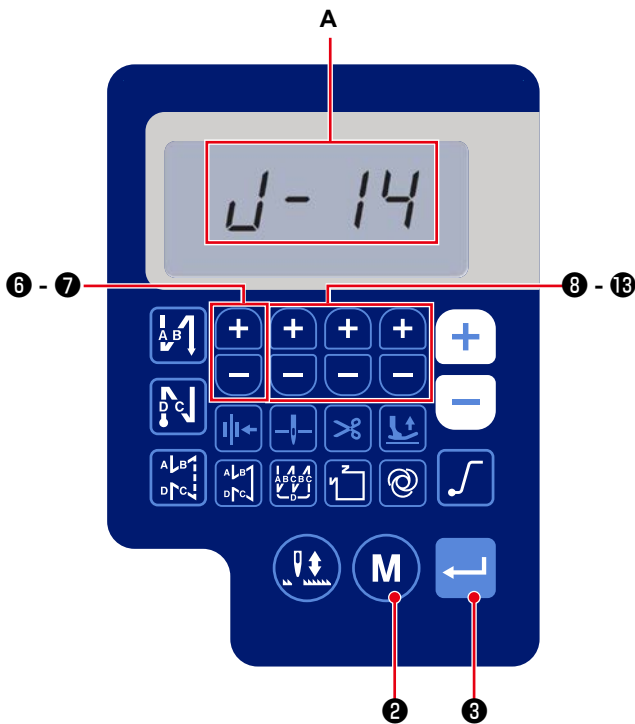

1) Turn the power ON while keeping **M** **2** or

**←** **3**, or **M** **2** and **←** **3** held pressed simultaneously. (This function is activated under the service level.)

2) Press **+** **-** **8** to **13** to select the function setting No. 70 (A).

3) Confirm the data with **←** **3**.

4) Set a four-digit password by pressing **+** **-** **6** to **13**.

**Caution** Write down the password you have set so to remember it.

5) Press **←** **3** to determine the password and return the sewing machine to the normal sewing state.

6) In the case the password is other than "0000", the password input screen is displayed before displaying the function setting screen by pressing **M** **2** in the normal sewing state (B).

7) Enter the four-digit password set with [Function setting No. J14] using **+** **-** **6** to **13**.

8) The function setting screen is displayed by pressing **←** **3**. On this screen, the functions can be set.

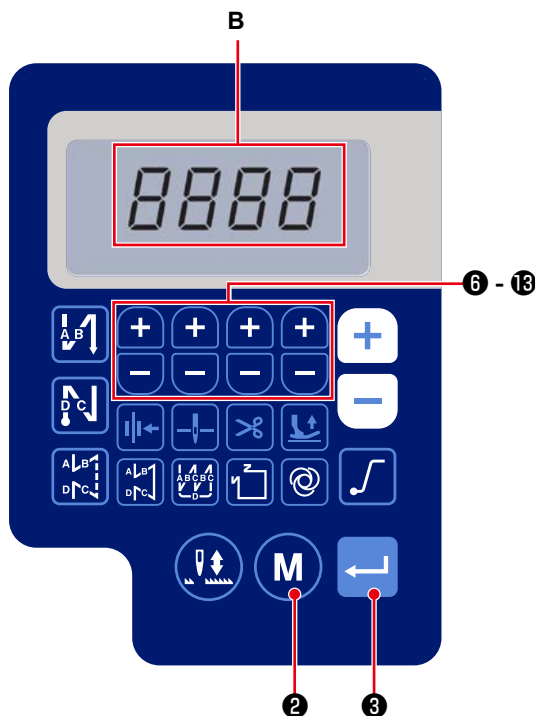

### 13. About the USB



**WARNING :**

The device to be connected to the USB port should have the rated current value or less as shown below.

If any device rated current value of which is higher than the rated current value, the main body of the sewing machine or the USB device connected can be damaged or malfunction.

Rated current value of the USB port

USB port on the electrical box side: Maximum rated current value of 1 A

#### [Insertion position of the USB thumb drive]

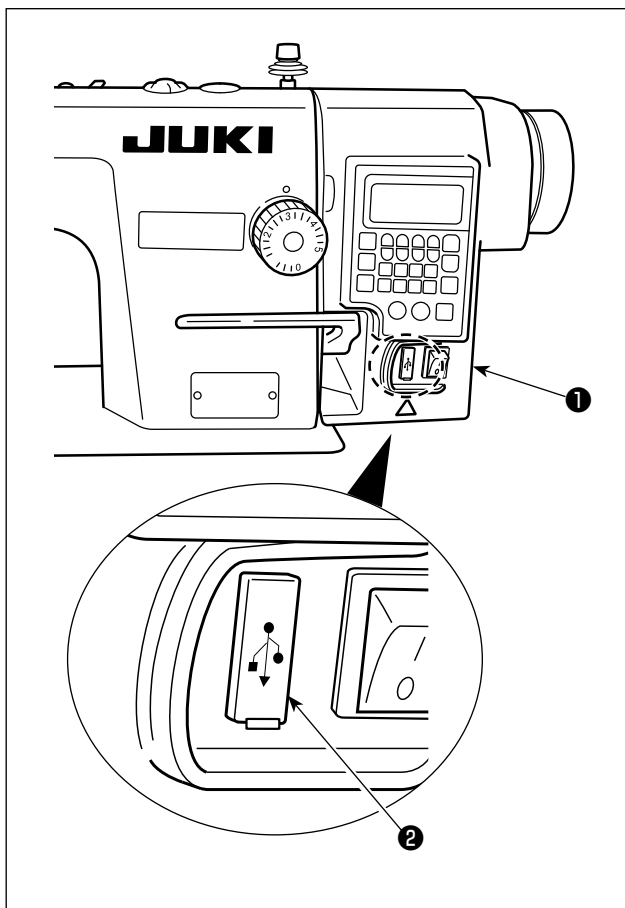

The USB connector is equipped on the electrical box ① .

To use a USB thumb drive, remove connector cover ② and insert the USB thumb drive into the USB connector.

\* In the case a USB thumb drive is not used, the USB connector should be protected with connector cover ② without exceptions.

If dust or the like enters the USB connector, a failure can be caused.

## 14. List of error codes

Error number	Description	How to correct
E-01	High-voltage error (320 V or more)	Turn the power OFF. Check the supply voltage.
E-02	Low-voltage error (170 V or less)	Turn the power OFF. Check the supply voltage.
E-03 E-03P	CPU communication fault	Turn the power OFF. Check the connection of the connector to the operation panel and the cable.
E-05	Pedal connection fault	Turn the power OFF. Check the connection of the connector to the pedal and the cable.
E-07	Main shaft rotation fault	Check whether the main shaft motor is locked by turning the pulley. Check the connection encoder cable and motor power cable to the connectors. Check whether the supply voltage is normal. Check whether the sewing speed is set extremely high.
E-08	Reverse feed stitching lever operation time is exceeded.	Turn the OFF. Then, re-turn ON the power.
E-09 E-11	Encoder Z-phase detection fault	Turn the power OFF. Check the connection of the motor encoder cable to the connector.
E-10	Solenoid overcurrent	Turn the power OFF. Check whether the solenoid has failed.
E014	Encoder AB-phase detection fault	Turn the power OFF. Check the connection of the motor encoder cable to the connector.
E015	Main shaft motor overcurrent error	Turn the power OFF. Then, re-turn the power ON.
E017	Machine head tilting error	Raise the machine head. Then, turn the power OFF and re-turn the power ON. Check whether the machine head tilt switch has broken.
E020	Main shaft rotation fault	Turn the power OFF. Check the connection of the main shaft motor encoder cable and motor power cable to the connectors.