

直驱中厚料同步车一体机

DIRECT DRIVE MEDIUM&HEAVY WEIGHT MATERIALS
SYNCHRONOUS BED SEWING MACHINE

使用说明书 零件手册
OPERATION INSTRUCTION PARTS BOOK

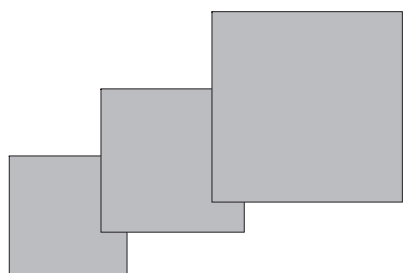

使用说明

使您正确使用本机,须对本机的各种功能充分了解,以便安全操作。

使用前请仔细阅读使用说明书,我们希望您能长期愉快地使用本机,请保存好说明书,以备查阅。

1. 无论您何时使用本机,须了解基本的安全事项,包括但不限于下列事项。
2. 通读所有说明,并保存好使用说明书。如果需要,请随时翻阅。
3. 使用本机前,必须弄清与本机有关安全规定、标准在您的国家是否适用。
4. 使用本机前或使用本机时,所有安全装置必须配备齐全。机器运转时,无安全装置属违章操作,决不允许。
5. 操作人员必须经过适当的培训。
6. 为了您的人身安全,我们建议您戴上防护眼镜。
7. 下列情况下,请关闭电源开关或拔下电源插头:
 - 7-1 机针穿线和换梭心;
 - 7-2 更换机针、压脚、针板、送料牙、旋梭等;
 - 7-3 进行维修时;
 - 7-4 操作区无人时。
8. 在机器加油润滑时,若不小心让油接触眼睛、皮肤或咽下机油或润滑油,请立即清洗被沾染部位或去医院检查。
9. 无论机器运转与否,严禁乱动机器零部件和配套装置。
10. 机器的维修、改造和调整等工作必须由专业技术人员进行。
11. 应由专业受训人员进行一般的维修和检查工作。
12. 必须在专业电器人员或专业技术人员的指导下进行有关电器部件的维修,任何电器部件一经发现受损,立即停止机器运转。
13. 使用期间要定期全面彻底清洗机器。
14. 正常操作本机时,必须进行试运转,工作环境远离强噪音源,如高频电焊机等。
15. 由电气人员选择合适的插头和有地线的插座。
16. 若需要改造或改进本机,请采用有效可行的安全措施。本公司对由此而产生的伤害不承担责任。

17. 本机只适用于专业缝纫。

18. 两种警告提示符：



操作人员或维修人员请注意



特别注意事项

INSTRUCTION MANUAL

To get the most out of the many functions of this machine and operate it insafely,it is necessary to use this machine correctly.

Please read this Instruction Manual carefully before use.We hope you will enjoy the use of your machine for a long time.Please remember to keep this manual in a safe place.

1. Observe the basic safety measures, including, but not limited to the following ones, whenever you use the machine.
2. Read all the instructions, including, but not limited to this Instruction Manual before you use the machine, in addition, keep this Instruction Manual so that you may read it at any-time when necessary.
3. Use the machine after it has been ascertained that it conforms with safety rules/standards valid in your country.
4. All safety devices must be in position when the machine is ready for work or in operation The operation without the specified safety devices is not allowed.
5. This machine shall be operated by appropriately-trained operators.
6. For your personalprotection,we recommend that you wear safety glasses.
7. For the following, turn off the power switch of disconnect the power plug of the machine from the receptacle.
 - 7-1 For threading needle(s) and replacing bobbin.
 - 7-2 For replacing part(s) of needle, presser foot, throat plate, feed dog, Hook assy etc.
 - 7-3 For repair work.
 - 7-4 For when leaving the working place of when the working place is unattended.

8. If you should allow oil, grease, etc. used with the machine and devices to come in contact with your eyes or skin or swallow any of such liquid by mistake, immediately wash the contacted areas and consult a medical doctor.
9. Tampering with the live parts and devices, regardless of whether the machine is powered, is prohibited.
10. Repairing, remodeling and adjustment works must only be done by appropriately trained technicians or specially skilled personnel.
11. General maintenance and inspection works have to be done by appropriately trained personnel.
12. Repair and maintenance works of electrical components shall be conducted by qualified electric technicians or under the audit and guidance of specially skilled personnel. Whenever you find a failure of any of electrical components, immediately stop the machine.
13. Periodically clean the machine throughout the period of use.
14. Grounding the machine is always necessary for the normal operation of the machine. The machine has to be operated in an environment that is free from strong noise sources such as high-frequency welder.
15. An appropriate power plug has to be attached to the machine by electric technicians, Power plug has to be connected to grounded receptacle.
16. Remodel or modify the machine in accordance with the safety rules/standards while taking all the effective safety measures. We assume no responsibility for damage caused by remodeling or modification of the machine.
17. The machine is only allowed to be used for the purpose intended. Other uses are not allowed.
18. Warning hints are marked with the two shown symbols.



Danger of injury to operator or service staff



Items requiring special attention

安全操作事项



1. 避免触电,请不要打开电机的电箱盖,也不要触摸电箱内部组件。



1. 避免人身伤害,移动防护罩、护手挡或安全装置时,请不要开动机器。
2. 尽可以避免机器运转造成的人身伤害,手指、头部和衣服应远离上轮,上轮周围不要放置任何物品。
3. 避免人身伤害,当您打开电源开关或操作机器时,切勿将手放在机针下方。
4. 避免人身伤害,机器运转时,切勿将手放入挑线杆防护罩内。
5. 旋梭运转时,勿将手指放在旋梭附近。另外,换梭芯时,请关掉机器电源开关。
6. 尽可以避免人身伤害,当翘起或抬起机头时,勿将手指放入机器内部。
7. 尽可以避免机器的突然启动所造成的事故,抬起机头时,请关掉机器的电源。
8. 机器配有电机,机器未运转时,电机无噪音; 避免机器的突然启动所先造成的事故,请关掉机器的电源开关。
9. 尽可能避免触电或电器组件受损,在插上或拔下插头之前,请关掉电源开关。

FOR SAFE OPERATION



1. To avoid electrical shock hazards, neither open the cover of the electrical box for the motor nor touch the components mounted inside the electrical box.



1. To avoid personal injury, never operate the machine with any of the belt cover, finger guard or safety devices removed.
2. To prevent possible personal injuries caused by being caught in the machine. Keep your fingers, head and clothes away from the handwheel, cover and the motor while the machine is in operation. In addition, place nothing around them.
3. To avoid personal injury, never put your hand under the needle when you turn ON the power switch or operate the machine.
4. To avoid personal injury, never put your fingers into the thread take-up cover while the machine is in operation.
5. The hook rotates at a high speed while the machine is in operation. To prevent possible injury to hands, be sure to keep your hands away from the vicinity of the hook during operation. In addition, be sure to turn OFF the power to the machine when replacing the bobbin.
6. To avoid possible personal injuries, be careful not to allow your fingers in the machine when tilting/raising the machine head.
7. To avoid possible accidents because of abrupt start of the machine, turn OFF the power to the machine when tilting the machine head.
8. If your machine is equipped with a servo-motor, the motor does not produce noise while the machine is at rest. To avoid possible accidents due to abrupt start of the machine, be sure to turn OFF the power to the machine.
9. To prevent possible accidents because of electric shock or damaged electrical component(s), turn OFF the power switch in prior to the connection /disconnection of the power plug.

使用说明

Operation Instruction

目录

CONTENTS

1	机器简介 Brief Introduction	3
2	主要技术规格 Main Technical Specifications	3
3	机器的安装 Mounting The Machine	4
4	机器的润滑 Lubrication	4
5	旋梭油量调节 Oil mass Adjustment of Rotating Hook	5
6	机针的装法 Mounting the Needle	7
7	梭芯的装法 Mounting the Bobbin	8
8	面线的穿法 Threading the Needle Thread	8
9	底线的卷绕 Winding up the Bobbin Thread	8
10	针距的调节 Adjusting the Stitch Length	10
11	线架的安装 Mounting the Thread Stand	10
12	膝提度的调节 Adjusting the Knee Lifting Height	11
13	挑线簧的调节 Adjusting the Take-up Spring	11
14	缝线张力调整 Adjusting the Tension of Stitch Thread	12
15	缝纫及倒缝 Sewing and backtacking	13
16	挑线杆挑线量的调节 Adjusting the Take-up Amount of Take-up Lever	13
17	压脚压力的调节 Adjusting the Presser foot Pressure	14

18	手动抬压脚 度 的调节 Adjusting the Manual Foot Lifting Height	14
19	送料牙的 度 Height of the feed dog	15
20	送料牙的倾斜 To tilt the feed dog	15
21	调节机针与送布机构同步 Adjusting the timing of needle and feed mechanism	16
22	机针与旋梭的位置的调整 Adjusting the Positions of Needle and Rotating Hook	17
23	调节倒顺缝针距误差 Adjusting the difference of stitch length between the forward and backtacking	18
24	调节松线器的挺线 Adjusting the tension release	18
25	调节油泵供油 Adjusting the oil pump	18
26	调节摆压脚与小压脚交替提升量 Adjusting the lifting amount if presser feet	19
27	剪线装置的调整 Adjusting the trimming mechanism	20
28	调节调节剪线后线头的长度 Adjusting the trailing length after thread trimming	23

1 机器简介

Brief introduction

直驱中厚料上下送料自动剪线平缝机系单直针，采用连杆式送料，连杆挑线机构，旋梭勾线，形成301线迹。

本机采用油泵自动润滑，运转轻滑，噪音低，振动小，特别适用于缝制皮革，帆布，厚重装饰布，织带类织物，如：箱包，汽车座垫，帐篷，沙发等。

电脑控制的剪线、定针数、定针位功能，准确可靠。

This machine is designed with link type feed mechanism and link lever thread take-up mechanism and full lubrication by pump.

It's suitable for sewing leather, canvas and other heavy weight materials; such as suitcase, car seat, tent, sofa, etc.

It's reliable and accurate on such functions as thread trimming, needle positioning, etc.

2 主要技术规格

Main Technical Specifications

规格	参数	
缝料	中厚料	
最高转速	2300针/分	
最大针距	8mm	
针杆行程	37mm	
压脚交互量	3.5-5.5mm	
采用机针	Dp×17 18#	
压脚提升高度	手控	8mm(最大)
	膝控	16mm(最大)
采用旋梭	自动润滑大旋梭	
供油方式	全自动供油	
电机功率	750W	

Specification	Parmeter	
Application	Medium & heavy weight materials	
Max sewing speed	2300s.p.m	
Max stitch length	8mm	
Needle bar stroke	37mm	
Lifting amount if presser feet	3.5-5.5mm	
Needle	Dp×17 18#	
Presser foot lift height	Hand lifter	8mm(Max)
	Knee lifter	16mm(Max)
Hook	Large lubrication hook	
Lubrication	Automatic lubrication	
Motor power	750W	

3 机器的安装 (图1、图2、图3、图4) Mounting the Machine (Fig.1, Fig. 2, Fig.3 and Fig. 4)

1.油盘的安装

1) 油盘②应放置在台板上的凹槽四角上。
2) 将两只机头座垫①安装在油盘②的A边 (朝操作者一边), 将两只油盘支座③安装在油盘②的B边 (机头连接钩接合一边), 然后放上油盘②。

3) 将机头连接钩⑤插入底板销孔内, 与台板的机头连接钩座④相嵌合再把机头放到油盘四只角的机头座垫上。

1. Fixing oil tray

1) Put the oil tray ② on the four groove corners on the sewing table.

2) Fix two arm cushion ① to the A side of oil tray ② (facing the operator). Fix the two stand bases ③ to the B side of oil tray ② (hinge side), then fix the oil tray ②.

3) Insert machine head coupling hook ⑤ into the pin holes in the bottom plate such that it is embedded into the coupling hook seat ④, and put the machine head onto the seating washer on four corners of the oil tray.



图1 Fig.1



图2 Fig.2

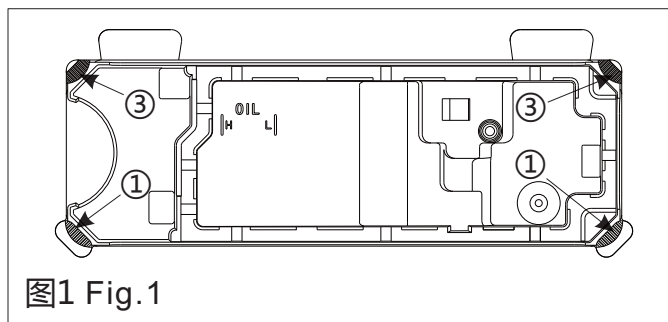

图3 Fig.3

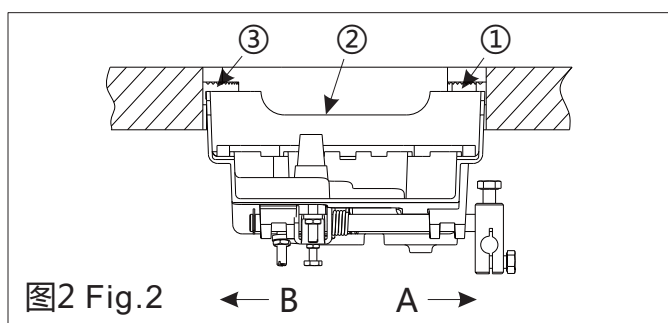

图4 Fig.4

4 机器的润滑 (图5) Lubrication (Fig.5)

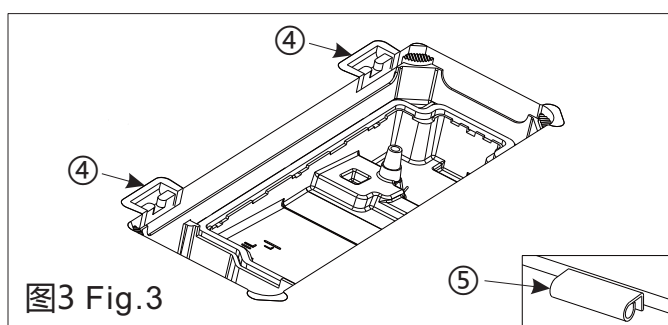
1. 润滑须知

1) 向油盘①注入缝纫机油 (10号白油) 至“H”记号A。
2) 当油面低于“L”记号B时, 应再加油。

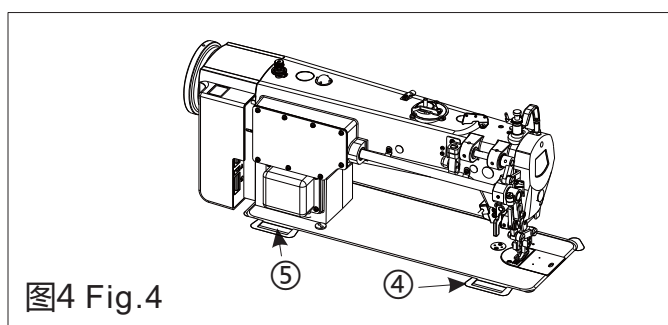
1. Information on lubrication

1) Fill oil pan ① with sewing machine oil (10 while oil) up to H mark A.
2) When the oil level lowers below L mark B, refill the oil pan with the specified oil.

3) 加油后，开动机器，应看到油液飞溅到油窗②上，说明润滑正常。

4) 至于飞溅的油量多少与总润滑油量多少无关。

3) When you operate the machine after lubrication, you will see splashing oil through oil sight window ② if the lubrication is adequate.

4) Note that the amount of the splash oil is unrelated to the amount of the lubricating oil.



注意:

1. 为了防止缝纫机的意外启动，请关掉电源之后再进行操作。



Caution:

1. To prevent the unexpected startup of sewing machine, trim off the power supply before the operation is conducted.



图5 Fig.5

5 旋梭油量调节 (图6、图7、图8) Oil mass Adjustment of Rotating Hook (Fig. 6, Fig. 7, Fig. 8)

1. 调节方法

1) 旋梭的油量是用旋梭油量调节螺钉①来调节：当旋梭油量调节螺钉朝 + 方向A转动时，油量将增大；朝 - 方向B转动时，油量将减小。

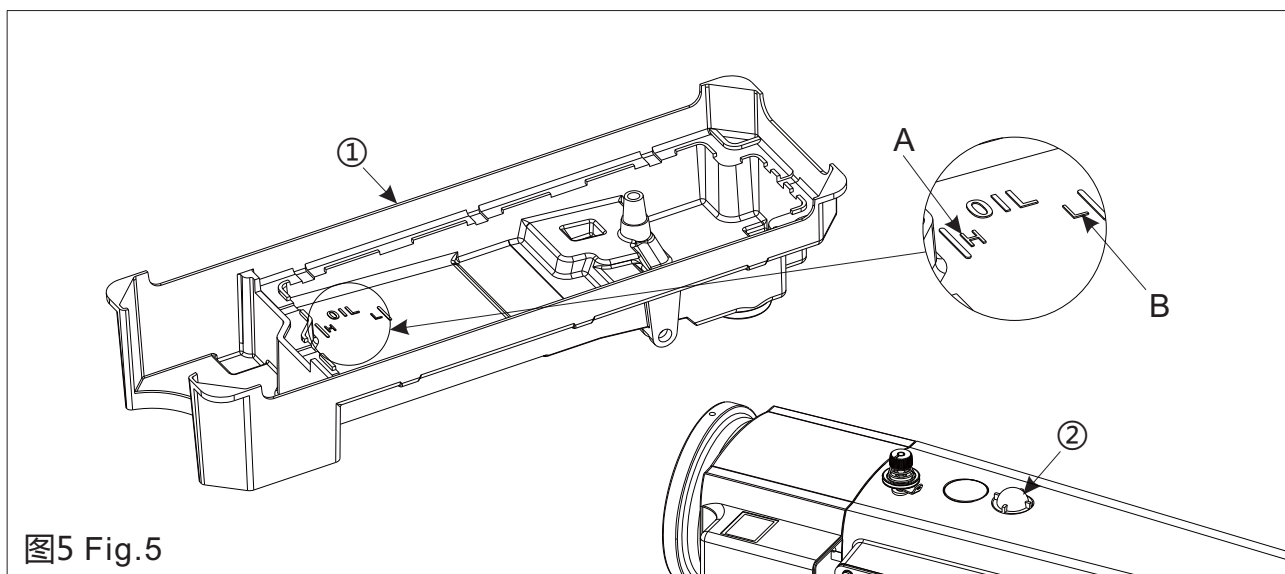
2) 调节油量后缝纫机应进行约30秒钟的空转，以确认油量状态。

1. Adjustment method

1) Adjust the oil mass of rotating hook using adjusting screw ①: Turning the adjusting screw of the front shaft sleeve on bottom shaft towards + direction A, the oil amount will increase, and towards - direction B, the oil amount will decrease.

2) When adjustment of oil mass is over, allow the sewing machine to idle for about 30 seconds to confirm the state of oil mass.



注意:

1. 为了防止缝纫机的意外启动，请关掉电源之后再进行操作。



Caution:

1. To prevent the unexpected startup of sewing machine, trim off the power supply before the operation is conducted.



2.油量的确认方法

1) 机头冷却时, 请进行三分钟左右的空转(适当的间歇运转)。

2) 请在缝纫机转动时将油量确认专用纸插入(具体操作见图8所示)。

3) 油量确认时间 5秒。



注意:



- 1.进行上述操作时, 确认油盘内的油面高度处在“MAX”和“MIN”范围内。
- 2.旋梭是高速运转的。为了防止人身事故, 调节油量时, 要充分注意手指不要碰到旋梭。

1. Confirming the Oil Mass

1) To cool down the machine head, allow it idle for about 3 minutes (appropriate discontinuous running).

2) Insert the special oil mass confirmation paper when the sewing machine is rotating (detailed operations are described in Fig. 8).

3) Oil mass confirmation time lasts for 5 seconds.



Caution:



1. Prior to the above-mentioned operation, Make sure the oil height in the oil plate ranges between MAX and MIN.
2. Rotating hook works at high speed. To prevent human injury, the operator shall keep his fingers away from the rotating hook during oil mass adjustment.

3.油量适合标样

1) 右图标样(见图8)根据不同的缝制工序需求进行增或减的微调整, 但应注意不要增加或减少过多。油量过少时会引起旋梭发热, 油量过多时会污染缝料。

2) 用油量确认专用纸测试三次, 直至确认3次油量确认专用纸油迹均无变化 止。



图6 Fig.6



图7 Fig.7

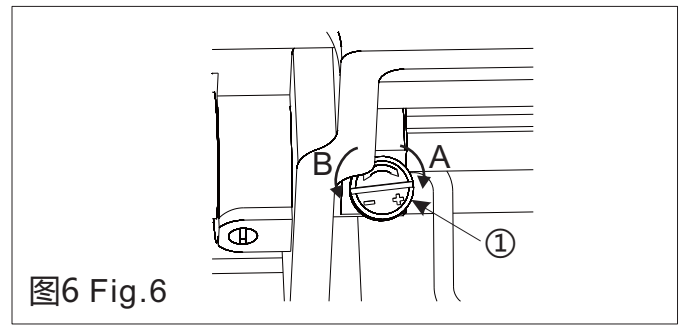

图8 Fig.8

3. Guide sample of oil mass adequacy

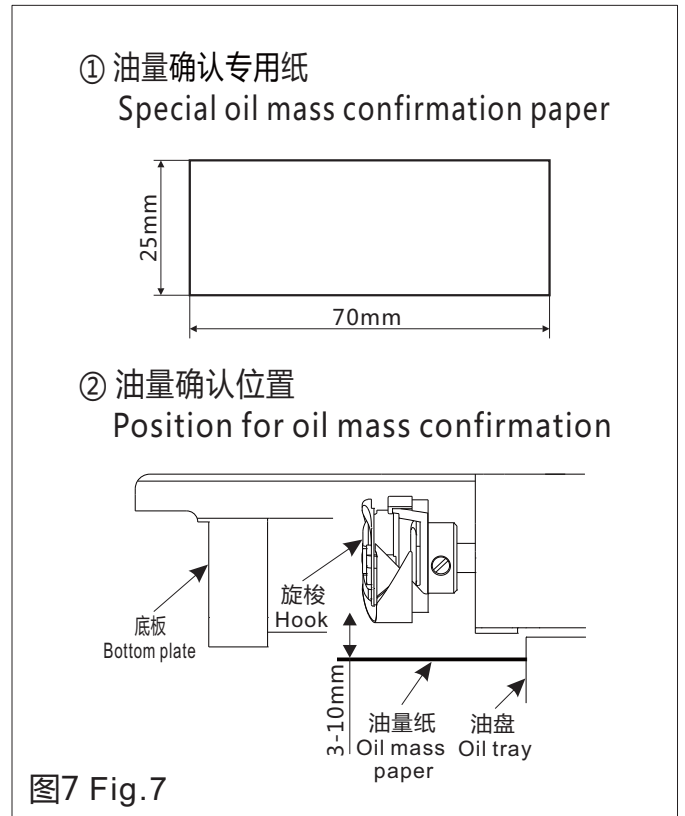
1) The guide sample shown in the right-hand figure (see Fig. 8) may be finely adjusted (increased or reduced) as per different sewing processes; however, excessive increase or reduction shall be avoided. Too little oil mass may lead to rotating hook heating, and overmuch oil mass may lead to contamination of the sewing materials.

2) Test the oil mass 3 times using special oil mass confirmation paper till the oil traces indicated by the special paper show no changes.

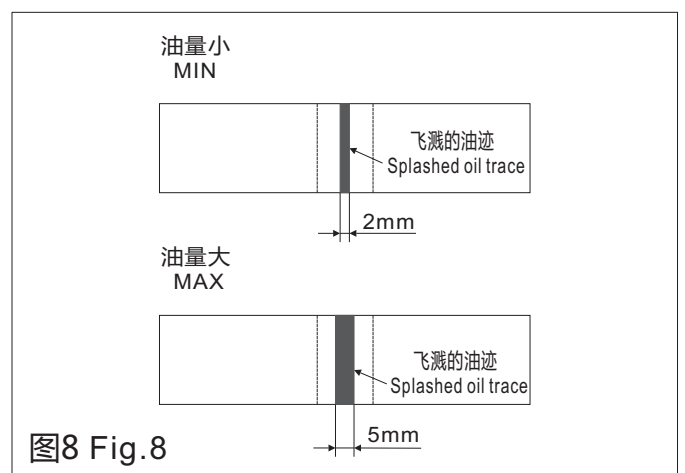
6 机针的装法 (图9) Mounting the Needle (Fig.9)

1. 转动上轮使机针上升到最高处。
2. 拧松夹针螺钉②，手拿机针①将机针①的凹弧部分A正对右方向B。
3. 将机针朝箭头方向插入针孔的底部，直至插不进 止。
4. 拧紧夹针螺钉②。
5. 务必使机针的长槽C正对左方向D。



注意:



1. 为了防止缝纫机的意外启动，请关掉电源之后再进行操作。
2. 机针有各种编号，请根据所用线的粗细和缝料来选择适当的机针。

1. Turn the upper wheel to allow the needle to reach its maximum height.

2. Unscrew needle carrying screw ②, hold needle ① by hand, and align the indentation A of needle to right direction B.

3. Insert the needle into the bottom of needle hole in direction of arrow till it reaches the end point.

4. Screw down the needle carrying screw ②.

5. Take care to ensure that the elongated slot C on the needle is aligned to the left direction D.



Caution:



1. To prevent the unexpected startup of sewing machine, trim off the power supply before the operation is conducted.

2. Needles are available in different sizes. Please select appropriate needle as per the thickness of threads and the sewing materials.



图9 Fig.9



图10 Fig.10

7 梭芯的装法 (图10) Mounting the Bobbin (Fig. 10)

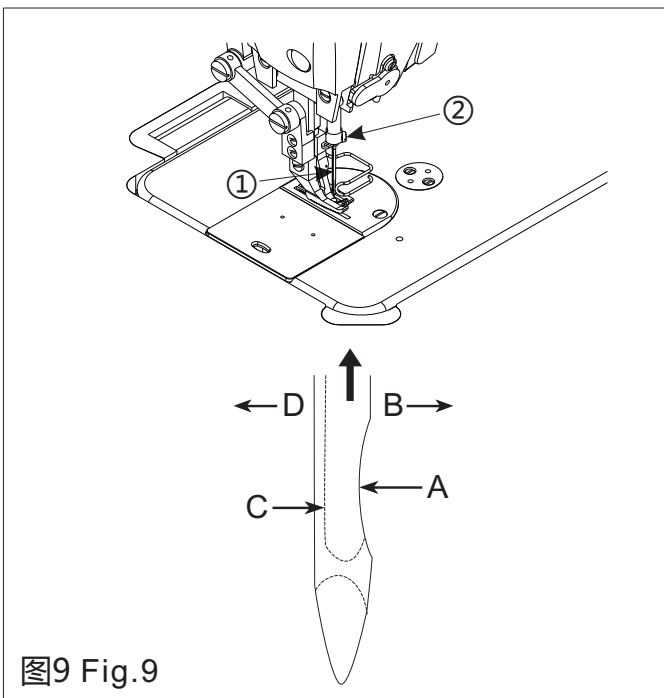
1. 拿住梭子，将梭芯装入梭子内。
2. 将线从梭子上的线槽A中穿过，朝C方向拉出。这样，线通过夹线簧从孔B处引出。
3. 拉底线时，梭芯应按箭头方向顺时针转动。

1. Hold the rotating hook by hand, and fit the bobbin into the rotating hook.
2. Thread the thread through the thread groove in the rotating hook, and draw out the thread in direction C. In this way, the thread is led out of hole B through the tension spring.
3. When bobbin thread is drawn, the bobbin shall turn clockwise in direction of arrow.

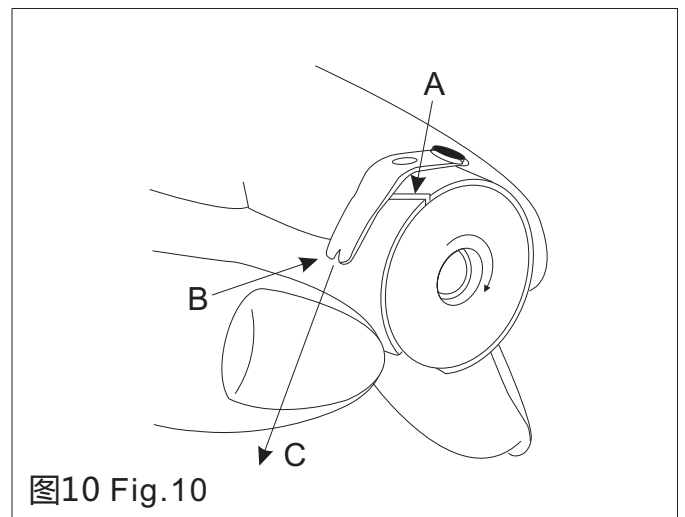
8 面线的穿法 (图11) Threading the Needle Thread (Fig. 11)

穿面线时针杆应在最高位置，然后由线架上引出线头按图示序号顺序进行穿线。

Thread the needle thread when needle bar stays in its highest position, lead out the thread end from the thread stand, and conduct threading as per the serial numbers indicated in the figure.

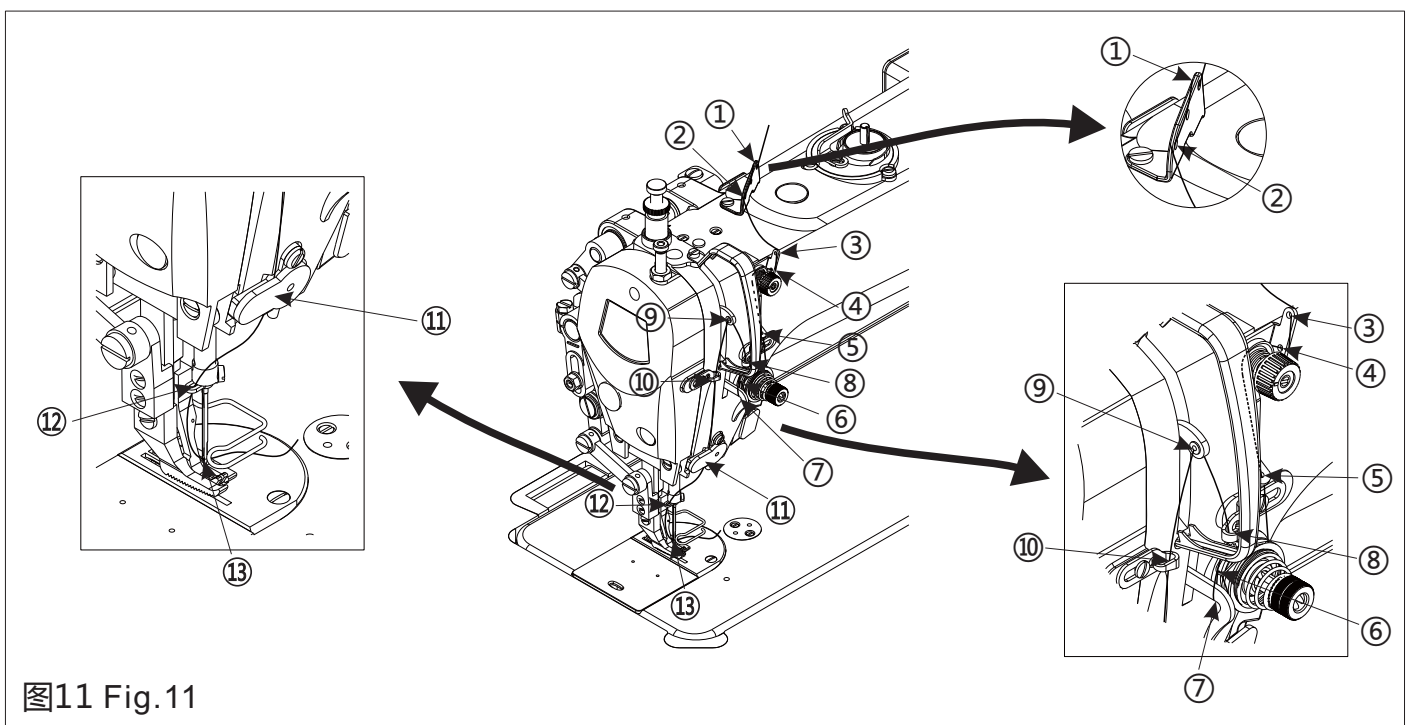

9 底线的卷绕 (图12、图13) Winding up the Bobbin Thread (Fig. 12, Fig. 13)

1. 底线卷绕的方法
 - 1) 把梭芯①装到绕线轴②上。
 - 2) 把线架右侧的卷线如右图所示穿线，并把线端向右 绕梭芯数 。
 - 3) 把卷绕手柄③推到A方向，然后运转缝纫

1. Bobbin thread winding-up method
 - 1) Fit bobbin ① onto spool ②.
 - 2) Thread the right-hand thread coiling on thread stand as shown in right-hand figure, and reel the thread end rightwards onto the bobbin for several turns.
 - 3) Push winding lever ③ over to direction

机。梭芯①向C方向转动，线卷绕到梭芯①上。卷绕线满后卷绕手柄③自动向B方向弹开并停止卷绕。

4) 取下梭芯①，用绕线切刀④切断机线。



注意:



1.卷绕底线时，请将要卷绕的底线处于梭芯①和夹线板③之间拉线状态下开始绕线。

2.不进行缝制时给梭芯①绕底线时，请把面线从挑线杆孔上抽出来，把梭芯①从旋梭里卸下来后再进行。



图12 Fig.12

2.底线卷绕的调节

1) 调整底线卷线量时，请拧松固定螺钉⑤，把卷绕手柄③移动到A方向或B方向，然后再固定螺钉⑤。A方向变少，B方向变多。

2) 如果线不能平绕梭芯时，请拧松螺母⑥，转动绕线夹线器，调整夹线板⑦的高度：

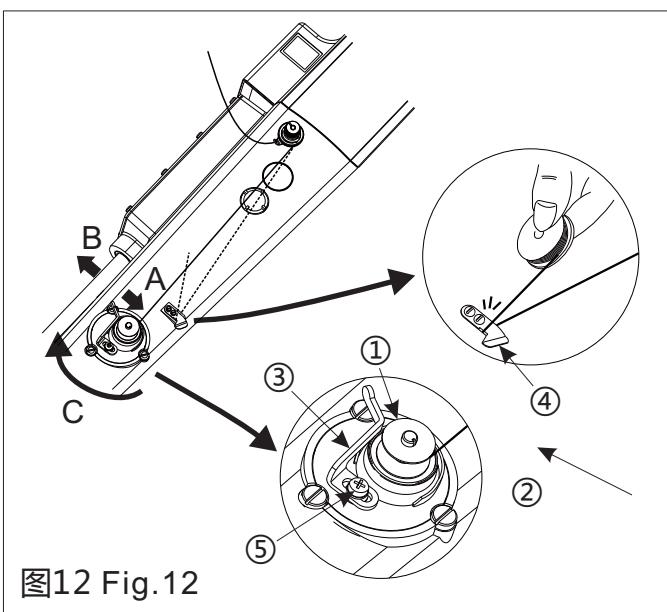
a.旋梭①中心和夹线板⑦中心高度一样时 标准位置。

b.下部卷的多时，向如右图D方向移动绕线夹线器的位置，上部卷的多时，向如右图E方向移动绕线夹线器的位置。

A, and run the sewing machine. Bobbin ① is rotated in direction C, and thread is reeled onto bobbin ①. Once the reel is full, winding lever ③ is pushed toward direction B, and winding is over.

4) Remove bobbin ①, and trim off the thread using winding trimmer ④.



Caution:



1.To reel the bobbin thread, set the bobbin thread to between bobbin ① and thread gripper plate ③ in taking-up mode, and start thread winding.

2.To reel bobbin thread onto bobbin ① when no sewing is performed, draw the needle thread out of hole in the take-up lever, remove bobbin ① out of rotating hook.



图13 Fig.13

1.Adjusting the bobbin thread winding

1)To adjust the winding capacity of bobbin thread, unscrew fixing screw ⑤, set winding lever ③ in direction A or direction B, and fix screw ⑤ again. Direction A is intended for reduction, and direction B is intended for increase.

2)If thread cannot be wound onto the bobbin flatly, unscrew nut ⑥, turn the winding tension disc, and adjust the height of height of thread gripper plate ⑦.

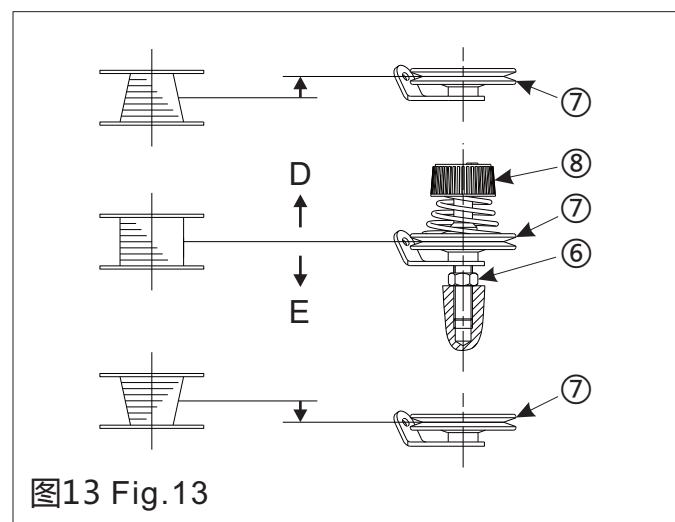
a.The standard position is reached once the center heights of rotating hook ① and thread gripper plate ⑦ are identical.

c.调整绕线夹线器到合适位置后，把固定螺钉⑥拧紧。

3) 调整底线卷绕张力时，请转动线张力螺母⑧进行调整。

b.If the winding amount on the lower part is bigger, move the winding tension disco in direction D indicated in the right-hand figure. If the winding amount on upper part is bigger, move the winding tension disco in direction E indicated in the right-hand figure.

c.When the winding tension disco reaches its suitable position, screw down fixing screw ⑥.

3)Adjust the winding tension of bobbin thread by turning thread tension nut ⑧.

10 针距的调节 (图14) Adjusting the Stitch Length (Fig. 14)

1.按下针距按键②，左右转动针距盘，将针距标盘上的数字对准针距按键②上的竖线标记。

2.数字越大，相应的针距越大。

3.当针距标盘上的数字从大向小方向转动时，将倒缝操纵杆③朝B向压至一半位置后，转动会更加轻松一些。

1.While press the stopper ②, turn the stitch length dial ① to make the number on the dial align with the mark on the stopper ②.

The number is the stitch length in mm.

2.The larger the number. The longer the stitch length will be.

3.When turn the dial from a larger setting to a smaller setting. It will be easy to turn if the reverse feed lever ③ in direction B, and turn the feeding distance knob.



图14 Fig.14



图15 Fig.15

11 线架的安装(图15) Mounting the Thread Stand (Fig.15)

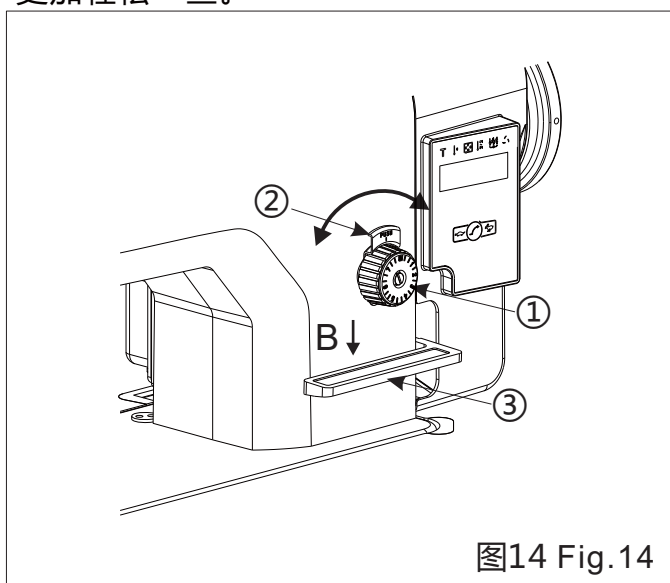
1.如右图所示那样将线架部件安装到缝纫机台板线架安装孔上。

2.旋紧线架杆下节固定螺母①固定线架。

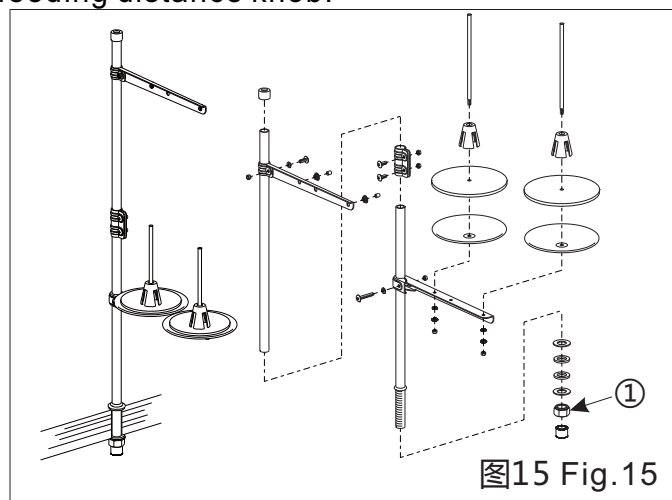
1.As shown in right-hand figure, mount the thread stand component onto the mounting hole for thread stand on the sewing machine table.

2.Screw down retaining nut ① for lower segment of thread stand lever to fix the thread stand.

12 膝提高度的调节 (图16、图17) Adjusting the Knee Lifting Height (Fig.16, Fig. 17)

1.膝提时的标准高度是13mm。

2.用膝提调整螺钉①可以调节压脚提升量，最大可至16毫米。



注意:

1. 为了防止缝纫机的意外启动，请关掉电源之后再进行操作。



2.当压脚提升超过16mm时，请不要运转缝纫机，因 针杆②与压脚③会相碰。

1.Standard knee lifting height is 13mm.

2.Knee-lifting adjusting screw ① may be used to adjust the lifting amount of presser foot, and the maximum lifting amount may reach 16mm.



Caution:

1.To prevent the unexpected startup of sewing machine, trim off the power supply before the operation is conducted.



2.When the presser foot lifting exceeds 16mm, do not run the sewing machine because needle bar ② may collide with presser foot ③.



图16 Fig.16



图17 Fig.17

13 挑线簧的调节 (图18、图19) Adjusting the Take-up Spring (Fig.18, Fig. 19)

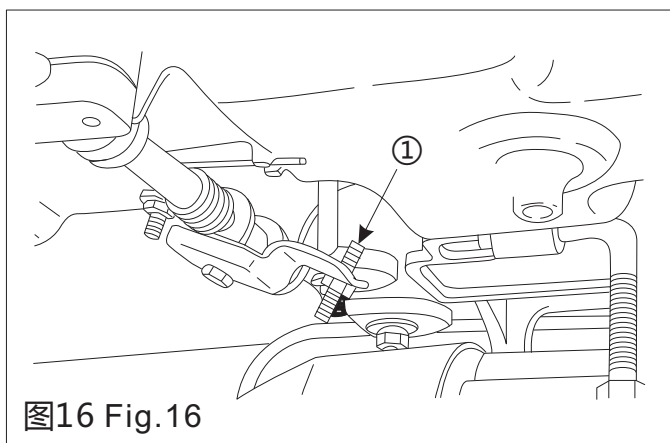
1.挑线簧摆动量的调节

1) 若将夹线器⑤中的螺钉③朝顺时针方向(即A方向)转动时，挑线簧①的摆动量将增大；若朝逆时针方向(即B方向)转动时，挑线簧①的摆动量将减小。

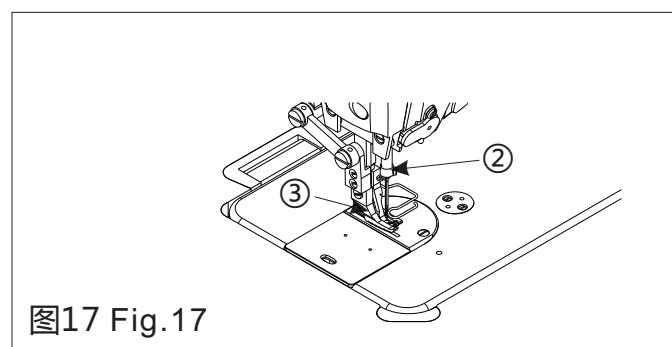
2.挑线簧张力的调节

1) 旋松螺钉②，取出夹线器⑤(组件)。

2) 旋松线器⑤中螺钉④。

3) 若将夹线器⑤中的螺钉③朝顺时针方向(即A方向)转动时，挑线簧①的张力将增大；若逆时针方向(即B方向)转动时，挑线簧①的张力将减小。

1.Adjusting the oscillating quantity of take-up spring

1) The oscillating quantity of take-up spring ① is increased if screw ③ in tension disco ⑤ is turned clockwise (namely in direction A), and it ① is reduced if the screw is turned counter clockwise (namely in direction B).

2.Adjusting the tension of take-up spring

1) Unscrew screw ②, and take out tension disco ⑤(assembly).

2) Unscrew screw ④ in tension disco ⑤.

3) The tension of take-up spring ① is increased if screw ③ in tension disco ⑤ is turned clockwise (namely in direction A), and it ① is reduced if the screw is turned counterclockwise (namely in direction B).

4) 调节结束后旋紧螺钉④，并将夹线器⑤(组件)装入机器中再旋紧螺钉②。

3.挑线簧调整适当的判断依据

1) 确认挑线簧①的张力调整后，把面线向B方向拉出，如果在挑线簧①达到最低位置之前面线B处就被拉动,请减弱挑线簧①的张力。

4) Screw down screw ④ when adjustment is over, fit tension disco ⑤(assembly) into the machine, and screw down screw ②.

3.Judgment basis for adjustment adequacy of take-up spring

1) Confirm that the tension of take-up spring ① is properly adjusted, draw out the needle thread in direction B. If place B of needle thread is drawn before take-up spring ① reaches its lowest position, reduce the tension of take-up spring ①.



注意:



1. 为了防止缝纫机的意外启动，请关掉电源之后再进行操作。

2.通常机器在出厂前,挑线簧均已调整妥善，只是在缝纫特殊的缝料或特殊的缝线时，才需要重新进行调整。



Caution:



1. To prevent the unexpected startup of sewing machine, trim off the power supply before the operation is conducted.

2. The take-up spring is already adjusted properly before the machine leaves the factory as a rule, and it requires readjustment only for sewing of special materials or usage of special stitch threads.

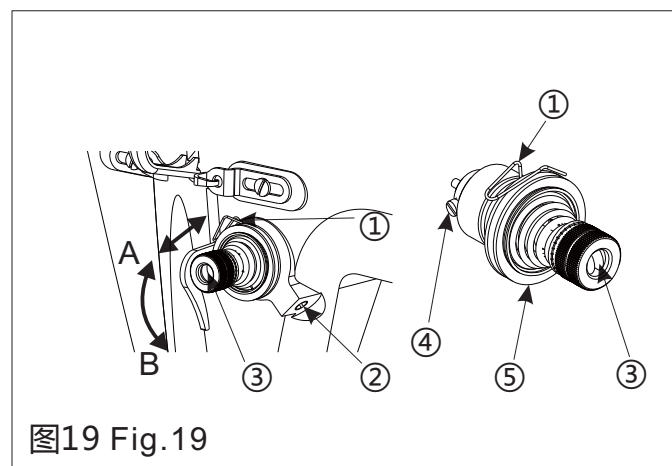
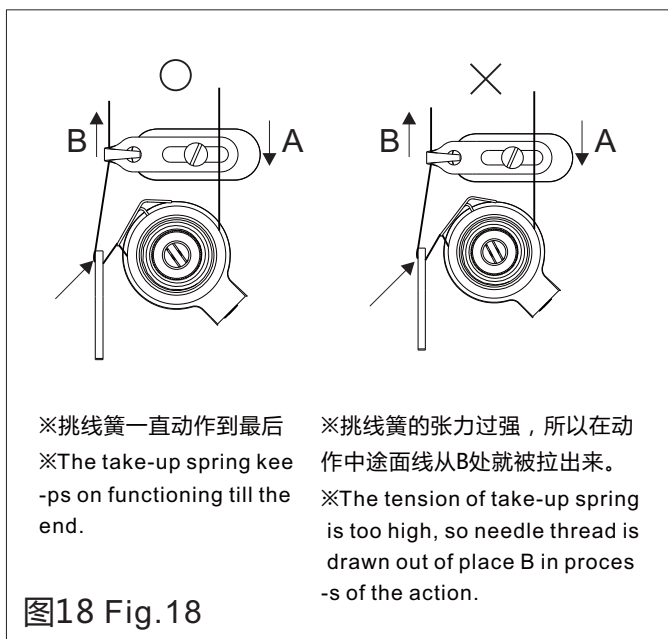

14 缝线张力调整 (图20) Adjusting the Tension of Stitch Thread (Fig.20)

1.面线张力的调节

1) 若将夹线器中的调节螺母①朝顺时针方向(即A方向)转动时，面线张力将增大；若朝逆时针方向(即B方向)转动时，面线张力将减小。

2.底线张力的调节

1) 若将夹线螺钉②朝顺时针方向(即C方向)转动时，底线张力将增大；若朝逆时针方向(即D方

-1.Adjusting the tension of needle thread

1) The tension of needle thread is increased if the adjusting nut ① in tension disco is turned clockwise (namely in direction A), and it is reduced if the nut is turned counterclockwise (namely in direction B).

2.Adjusting the tension of bobbin thread

1) The tension of bobbin thread is increased if the adjusting screw ② is turned clockwise (namely in direction A), and it is reduced if t

向)转动时，底线张力将减小。



注意:



1. 为了防止缝纫机的意外启动，请关掉

电源之后再进行操作。

the screw is turned counterclockwise (namely in direction B).



Caution:



1. To prevent the unexpected startup of sewing machine, trim off the power supply before the operation is conducted.



图20 Fig.20



图21 Fig.21

15 缝纫及倒缝 (图21) Sewing and backtacking (Fig.21)

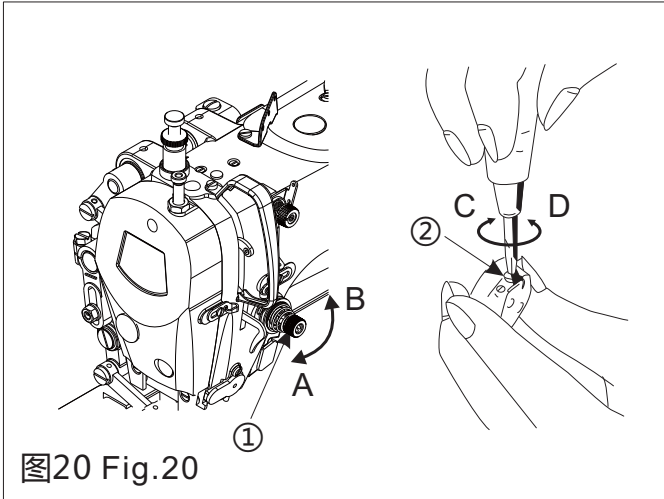

1. 按下电源开关。
2. 踩下踏板，缝制开始，正常缝制过程中，按下倒缝扳手①或按下自动倒缝开关②，便开始反向送料，松开后，则恢复正常送料。

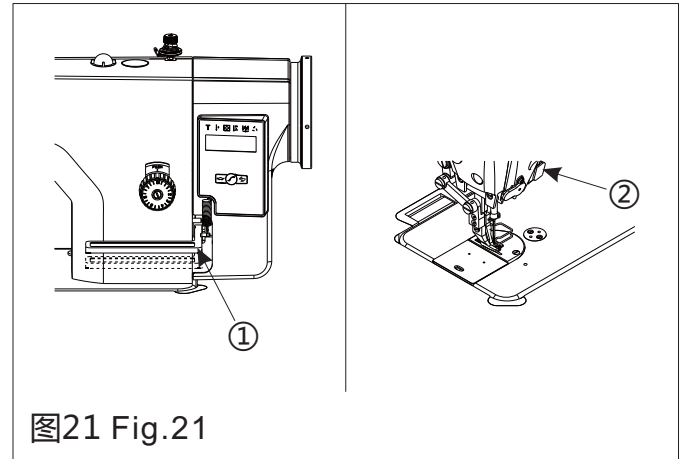

1. Turn the power on.
2. Depress the treadle to start sewing, when the reverse lever ① is pressed or the backtacking button ② is on during sewing, the feed will be reversed. After release, the feed will recover to normal.

16 挑线杆挑线量的调节 (图22) Adjusting the Take-up Amount of Take-up Lever (Fig.22)

1. 右线钩上的刻线C与螺钉中心一致时 标准位置。
2. 缝制厚料时，应旋松螺钉①再将右线钩②朝左方向(即A方向)移动，以增大挑线量，调节完成后旋紧螺钉①。
3. 缝制薄料时，应旋松螺钉①再将右线钩②朝右方向(即B方向)移动，以减小挑线量，调节完成后旋紧螺钉①。

1. The standard position is obtained when graduation line C on right thread hook is aligned to screw center.
2. For thick material sewing, unscrew screw ① and move right thread hook ② to the left (namely in direction A) to increase the take-up amount, and screw down screw ① when adjustment is over.
3. For thin material sewing, unscrew screw ① and move right thread hook ② to the right (namely in direction B) to reduce the take-up amount, and screw down screw ① when adjustment is over.

-  **注意:**
-  1. 为了防止缝纫机的意外启动，请关掉电源之后再进行操作。

-  **Caution:**
-  1. To prevent the unexpected startup of sewing machine, trim off the power supply before the operation is conducted.



图22 Fig.22



图23 Fig.23

17 压脚压力的调节 (图23) Adjusting the Presser Foot Pressure (Fig.23)

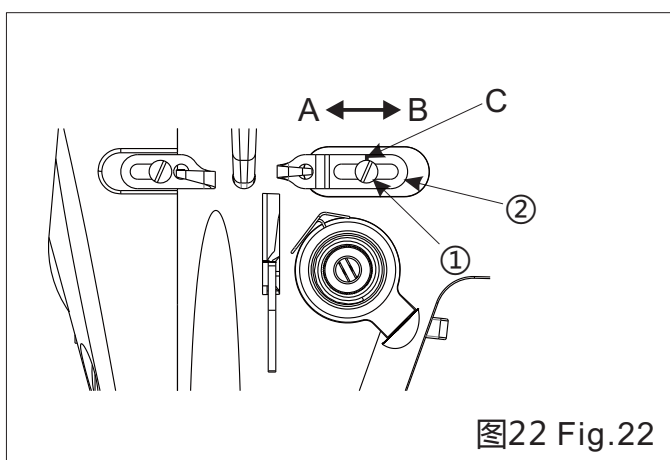
1. 旋松调压螺钉锁紧螺母①。
2. 转动调压螺钉②来调节压脚压力，在压力不够的情况下，可以转动螺钉⑤来增加压力。保证缝料不打滑的情况下，压脚压力尽可能的弱一些。
3. 拧紧调压螺钉锁紧螺母①。
4. 旋松锁紧螺母③。
5. 转动调节螺钉④来调节送料压脚的压力，顺时针转动调节螺钉④来增大压力，逆时针转动则减小压力。
6. 拧紧锁紧螺母③。

1. Loosen the lock nut ①.
2. Turn the adjusting screw ② to adjust the pressure of presser foot, if it's not enough, please turn the screw ⑤ to increase the pressure. The pressure should be as weak as possible, but strong enough so that the material doesn't slip.
3. Tighten the nut ①.
4. Loosen the nut ③.
5. Turn the screw ④ clock wise to increase the pressure, on the contrary, turn the screw counterclockwise to decrease the pressure.
6. Tighten the nut ③.

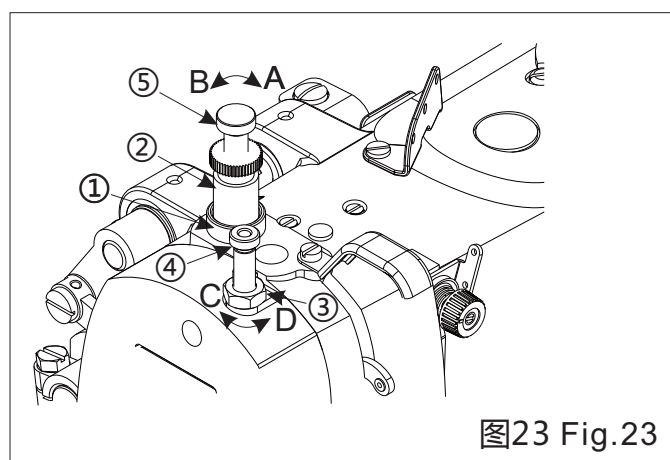
18 手动抬压脚高度的调节 (图24) Adjusting the Manual Foot Lifting Height (Fig.24)

1. 将压脚扳手朝顺时针转动使压脚抬起，旋松压杆导架紧固螺钉①，上下移动压杆②来调节手动抬压脚高度(压脚高度 针板面与压脚底面的距离，手动抬压脚高度的标准值 8mm)。
2. 调节结束后，拧紧压杆导架紧固螺钉①。

1. Turn clockwise the presser foot lever to up-lift the presser foot, unscrew tightening screw ① of presser bar spring bracket, moving upward/downward pressure bar ② to adjust the manual foot lifting height (presser foot height indicates the distance from the surface of needle plate to the bottom surface of presser foot, and



注意:

1. 为了防止缝纫机的意外启动, 请关掉电源之后再进行操作。

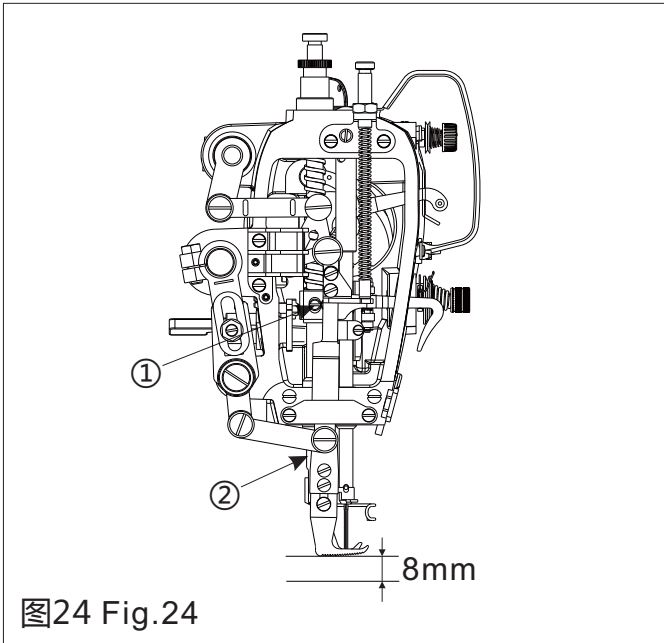

- the standard value of manual foot lifting height is 6mm).
2. When adjustment is over, screw down tightening screw ① of presser bar spring bracket.



Caution:

1. To prevent the unexpected startup of sewing machine, trim off the power supply before the operation is conducted.

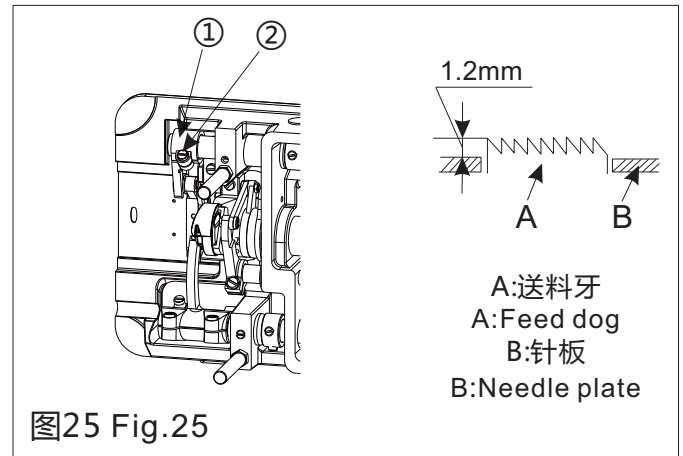

19 送料牙的高度 (图25) Height of the feed dog (Fig.25)

- 1.送料牙一般应比针板高出1.2毫米。
- 2.送料牙高度的调节
 - 1) 旋松抬牙叉形曲柄①的紧固螺钉②。
 - 2) 上下移动牙架进行调节。
 - 3) 旋紧曲柄螺钉②。

1. The feed dog is factory-adjusted so that it just out from the throat plate 1.2mm.
2. To adjust the height of the feed dog
 - 1) Loosen screw ② of crank ①.
 - 2) Move the feed bar up or down to make adjustment.
 - 3) Securely tighten screw ②.



注意:

1. 为了防止缝纫机的意外启动, 请关掉电源之后再进行操作。



Caution:

1. To prevent the unexpected startup of sewing machine, trim off the power supply before the operation is conducted.

20 送料牙的倾斜 (图26) To tilt the feed dog (Fig.26)

- 1.标准的倾斜, 是在牙架销上的刻点A与牙架曲柄①上的刻点B对齐。
2. 为了防止浮线, 要送料方向高, 则旋松固定螺钉, 用螺丝刀把牙架销朝箭头方向转动90°。

1. For standard adjustment, align point A with point B of the feed bracket.
2. To prevent thread float, it has to make the sending direction higher, so loose the screw and turn the feeding bar shaft 90° in the direction of the arrow with a screwdriver.

3. 为了防止缝料的潜移，要送料方向低，则牙架销朝箭头相反方向转动90°。

3.To prevent uneven material feed , turn the feeding bar shaft 90° in the opposite direction from the arrow with a screwdriver.



注意:



1. 为了防止缝纫机的意外启动，请关掉电源之后再进行操作。
- 2.无论什么时候，调节送料牙的倾斜，送料牙的高度会发生变化；所以，在调整之后，请再次确认送料牙的高度。



Caution:



- 1.To prevent the unexpected startup of sewing machine, trim off the power supply before the operation is conducted.
- 2.Whenever make the adjustment , the height of the feed dog changes. so after adjustment , please check the height of the feed dog again.



图26 Fig.26

21 调节机针与送布机构同步 (图27) Adjusting the timing of needle and feed mechanism(Fig.27)

标准位置：

当送布牙从最高位置下降，机针孔中心③应与针板上表面②、送布牙顶端①在同一水平面上。通过调整送布凸轮和抬牙凸轮的位置进行

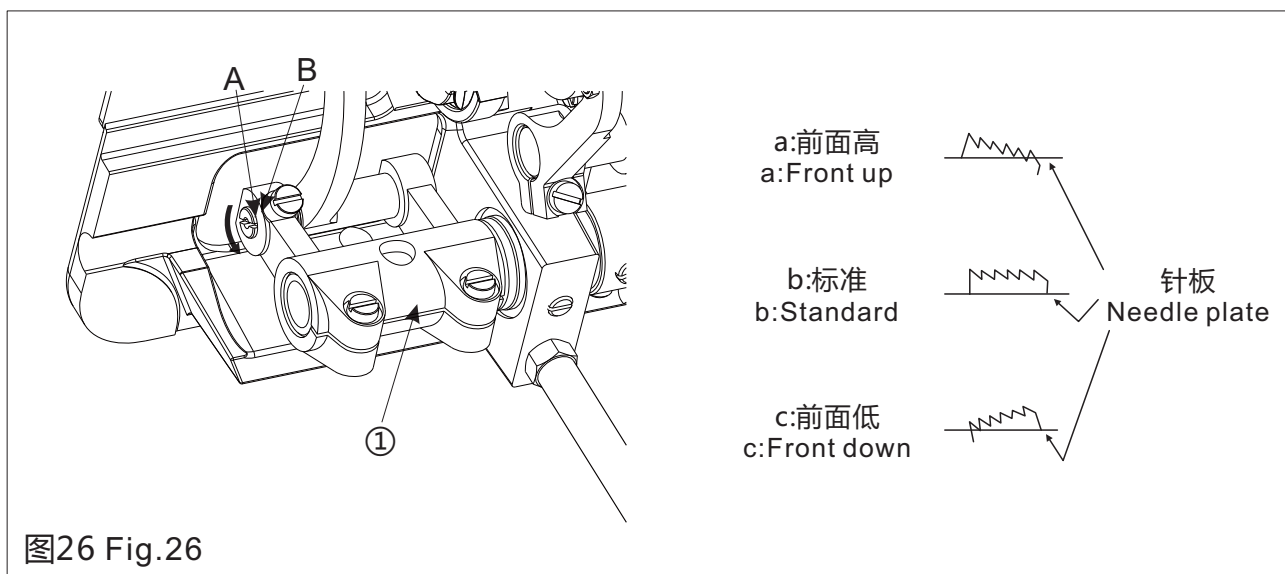
- 1.卸下后窗板。
- 2.逆时针转动上轮，以上轴齿轮第二只固定螺钉④ 基准，抬牙凸轮的第三只固定螺钉⑤中将对齐④中心稍微偏下一点。
- 3.继续逆时针转动上轮，以抬牙凸轮⑧第二只紧固螺钉⑥ 基准，送布凸轮的第三只紧固螺钉⑦中心将对齐⑥中心稍微偏上一点。

The standard timing is when the feed dog is lowered from its highest position until it is flush with the top of the needle plate ②, and the needle eye ③ is also aligned horizontally with the surface. Adjust by changing the phases of feed cam and eccentric wheel UD.

- 1.Remove the rear cover.
- 2.Turn the machine pulley in reverse direction. set the second screw ④ on the gear of upper shaft as reference mark, make the third screw ⑤ of eccentric wheel UD slightly lower than the reference mark screw ④.
- 3.Continue to turn the machine pulley, set the second screw ⑥ of eccentric wheel UD as reference mark, make the third screw ⑦ of feed cam slightly higher than the reference mark screw ⑥.



注意:

1. 为了防止缝纫机的意外启动，请关掉电源之后再进行操作。
2. 千万小心不要将送料偏心轮移动得太多，不然会造成断针现象。



Caution:

1. To prevent the unexpected startup of sewing machine, trim off the power supply before the operation is conducted.
2. Be careful not to move the feed eccentric cam too far, or else needle breakage may result.



图27 Fig.27

22 机针与旋梭的位置的调整 (图28) Adjusting the Positions of Needle and Rotating Hook (Fig.28)

1. 转动上轮，使针杆下到最低点，再旋松针杆连接柱紧固螺钉①。

2. 使针杆②上的刻线A对准针杆下轴套③的下端，然后旋紧针杆连接柱紧固螺钉①。

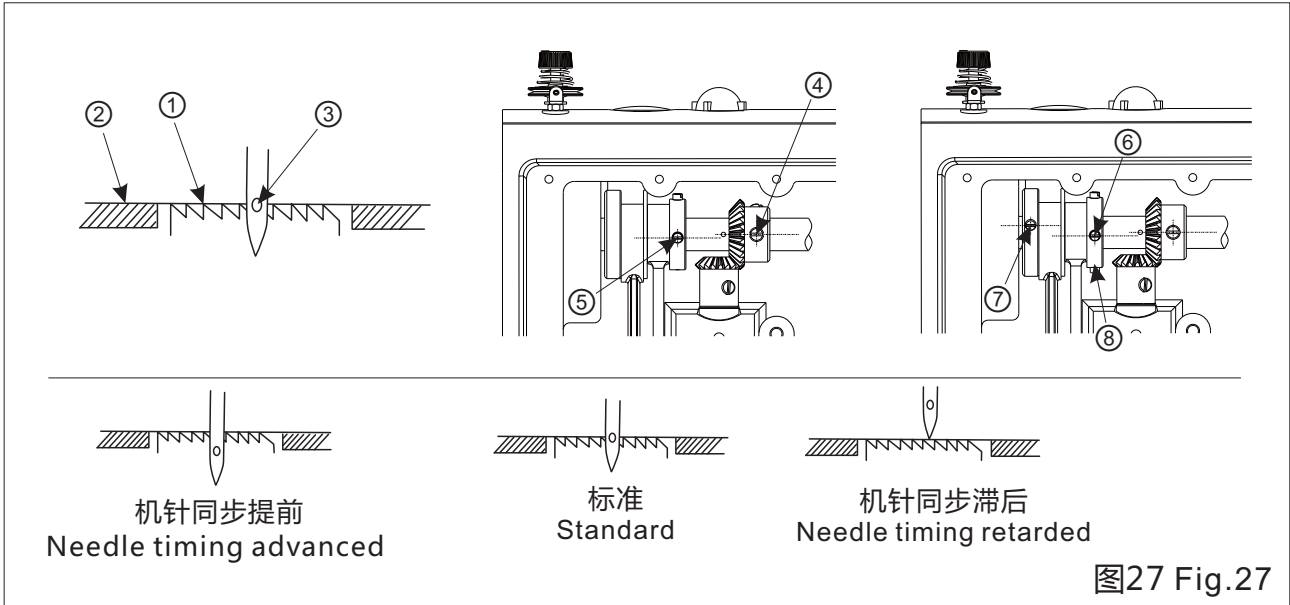
3. 旋松3颗旋梭紧固螺钉并转动上轮，使针杆②的上刻线B对准针杆下轴套③的下端。

4. 移动旋梭使旋梭的勾线尖⑤对准机针④的缺口处并使机针④的缺口处与旋梭的勾线尖⑤间隙 0.05mm，然后拧紧旋梭紧固螺钉。

1. Turn the upper wheel to allow the needle bar to reach its lowest point, and unscrew trip bolt ① of needle bar joint pin.

2. Align graduation line A on needle bar ② to the lower end of lower shaft sleeve ③ of needle bar, and screw down tightening screw ① of needle bar joint pin.

3. Unscrew 3 tightening screws of rotating hook, turn the upper wheel, and align graduation line B on needle bar ② to the lower end of lower shaft sleeve ③ of needle bar.

4. Move the rotating hook such that its threaded hooking tip is aligned to the notch on needle ④, ensure that the clearance between notch on needle ④ and thread hooking tip ⑤ ranges 0.5mm, and screw down the tightening screw of rotating hook.



注意:

1. 为了防止缝纫机的意外启动，请关掉电源之后再进行操作。
2. 若机针④的缺口处与旋梭勾线尖⑤的间隙过小，会磨损旋梭梭尖；若间隙过



Caution:

1. To prevent the unexpected startup of sewing machine, trim off the power supply before the operation is conducted.

大，会引起跳动针。



图28 Fig.28

2.If the clearance between notch on needle ④ and thread hooking tip ⑤ of rotating hook is too small, rotating hook tip may be worn; if the clearance is excessive, skipped stitch may take place.

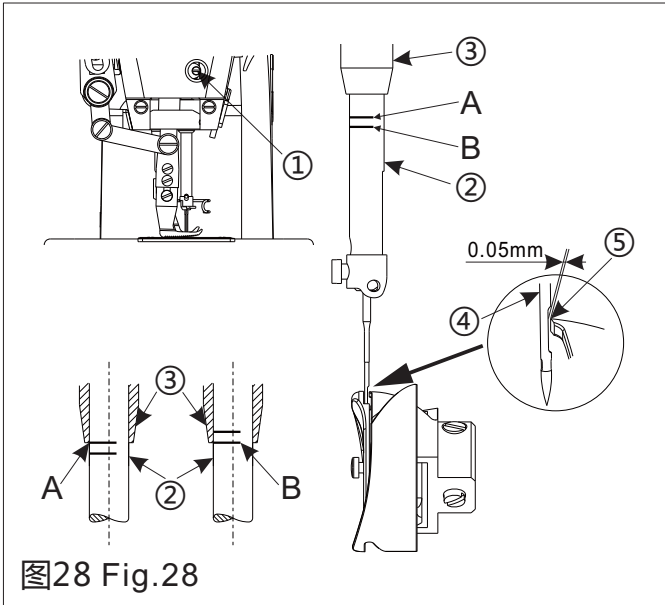

图29 Fig.29

23 调节倒顺缝针距误差(图29)

Adjusting the difference of stitch length between the forward and back tacking (Fig.29)

- 1.卸下后窗板。
 - 2.松开螺钉①，转动针距调节连杆偏心销钉②。
- *顺时针：顺缝针距变大，倒缝针距变小。
*逆时针：顺缝针距变小，倒缝针距变大。

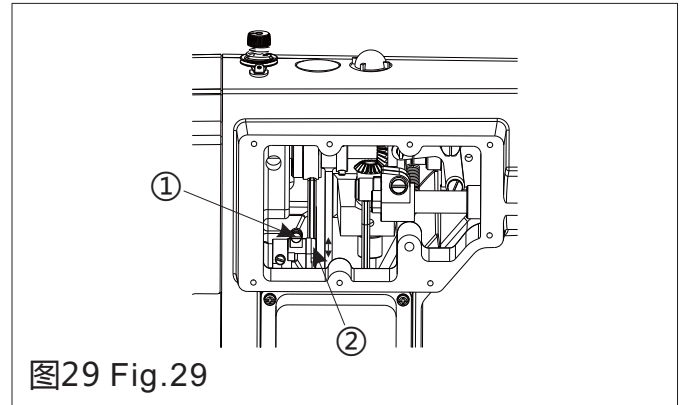
- 1.Remove the rear cover.
 - 2.Loosen the screw ①, and turn the connect-in stud ②.
- *Turn the stud ② clockwise, the forward stitch length will be longer and the back tacking stitch length will be shorter.
*Turn the stud ② clockwise, the forward stitch length will be shorter and the back tacking stitch length will be longer.

24 调节松线器的挺线(图30)

Adjust the tension release (Fig.30)

压脚在提升范围内，夹线器上的夹线板有一个张开期，挺线的时间可进行调节。调解时，先卸下机头后侧面的橡皮塞，用螺丝刀旋松膝控提升杠杆螺钉①，这是松线凸轮②可以左右移动，往右移挺线慢，往左移挺线快。

The opening time of the thread tension discs can be adjusted. Remove the rubber cap on the rear of arm, and turn the screw ① then the thread release cam ② can be moved left or right. Move the cam rightward, the release time will be slow. Move the cam leftward, the release time will be quick.

25 调节油泵供油(图31)

Adjust the oil pump (Fig.31)

当低速运转时，观察油窗，无喷油现象时，请转动供油调节板①，将其盖住油孔②。

If the oil is not circled observed from the oil gauge window at a lower sewing speed, turn the oil adjustment plate ① to cover the oil hole ②.



图30 Fig.30



图31 Fig.31

26 调节摆压脚与小压脚交替提升量(图32) Adjusting the lifting amount of presser feet (Fig.32)

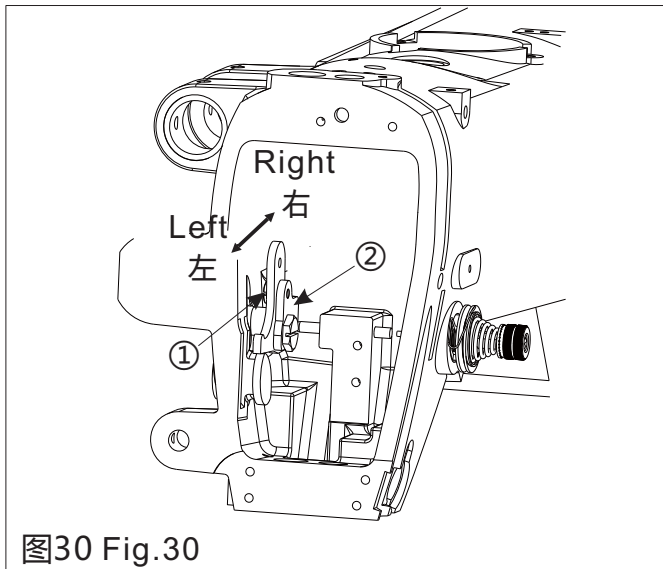
1.摆压脚①及小压脚②的垂直方向运动：

* 摆压脚及小压脚是交替式的上下运动。

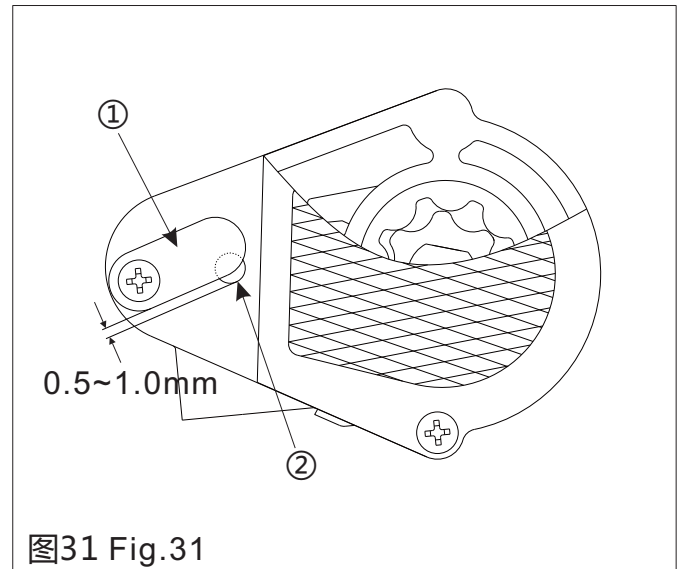
* 摆压脚及小压脚上升高度一般是相同的或是小压脚的上升高度略低一些。

将挑线杆置于最下位置，放下压脚扳手，松开螺钉③使压降升降前曲柄④左右移动来调节交替提升量。

右移：两压脚交替提升量趋于相同。

左移：小压脚的提升量减小。

2.摆压脚、小压脚前后方向间隙的调节：

根据缝料的不同要改变摆压脚，小压脚的提升量。先将偏心轮连杆螺钉⑤旋松，然后上下移动来调节螺钉与压脚升降轴的中心距，中心距调小，则各自的提升量都增加。

3.摆压脚、小压脚前后方向间隙的调节：

了在缝纫过程中，使摆压脚槽的前端与小压脚后端面不碰撞，必须保持适当的间隙C(3mm左右)。

旋松摆压脚前曲柄螺钉⑥，然后上下转动压脚摆动轴⑦来进行调节。

1.Vertical movement of presser foot ② and walking foot ①：

*The walking foot, and presser foot move vertically one after another.

*Usually the stroke of walking foot and presser foot is same or the stroke of presser foot is slightly lower.

Place the thread take-up lever at the lowest position, and lower the presser bar lifter, loosen the screw ③ and move the upper feed lifting cam ④.

Move it rightward to make the stroke of two feet be equal.

Move it leftward to make the stroke of presser foot be smaller.

2.Adjusting the lifting amount of two feet to materials to be sewn:

Loosen the screw ⑤, and move the screw upward to increase the lifting amount or move the screw downward to decrease the lifting amount.

3.Adjusting the forward/backward clearance of the two feet.

To keep the front groove of walking foot not strike the rear of the presser foot, the clearance of C must be kept about 3mm.

Loosen the screw ⑥ of feed arm R, and then turn then turn the feed rock shaft ⑦ to adjust.

4.Adjusting the feed amount of walking foot (Fig. A)

*The standard ration of feed amount between feed dog and walking foot is 1:1.

The feed amount of walking foot can be adjust

4. 摆压脚的调节 (见A部) :

* 送布牙送料量与摆压脚送料量之间的标准比率 1:1 (同步送料)。

摆压脚的送料量可根据缝料不同进行调整, 松开螺母⑧, 上下移动摆压脚滑块⑨来调节。

向上: 减小中心距L, 摆压脚送料量减小。

向下: 增大中心距L, 摆压脚送料量增大。

-ed to suit for the materials to be sewn. Loosen the nut ⑧, and move the slide block ⑨ to adjust. Upward: decrease the distance L to make the feed amount be smaller.

Downward: increase the distance L to make the feed amount be larger.



图32 Fig.32

27 剪线装置的调整 Adjusting the trimming mechanism

1. 剪线装置(图33) Trimming mechanism (Fig.33)

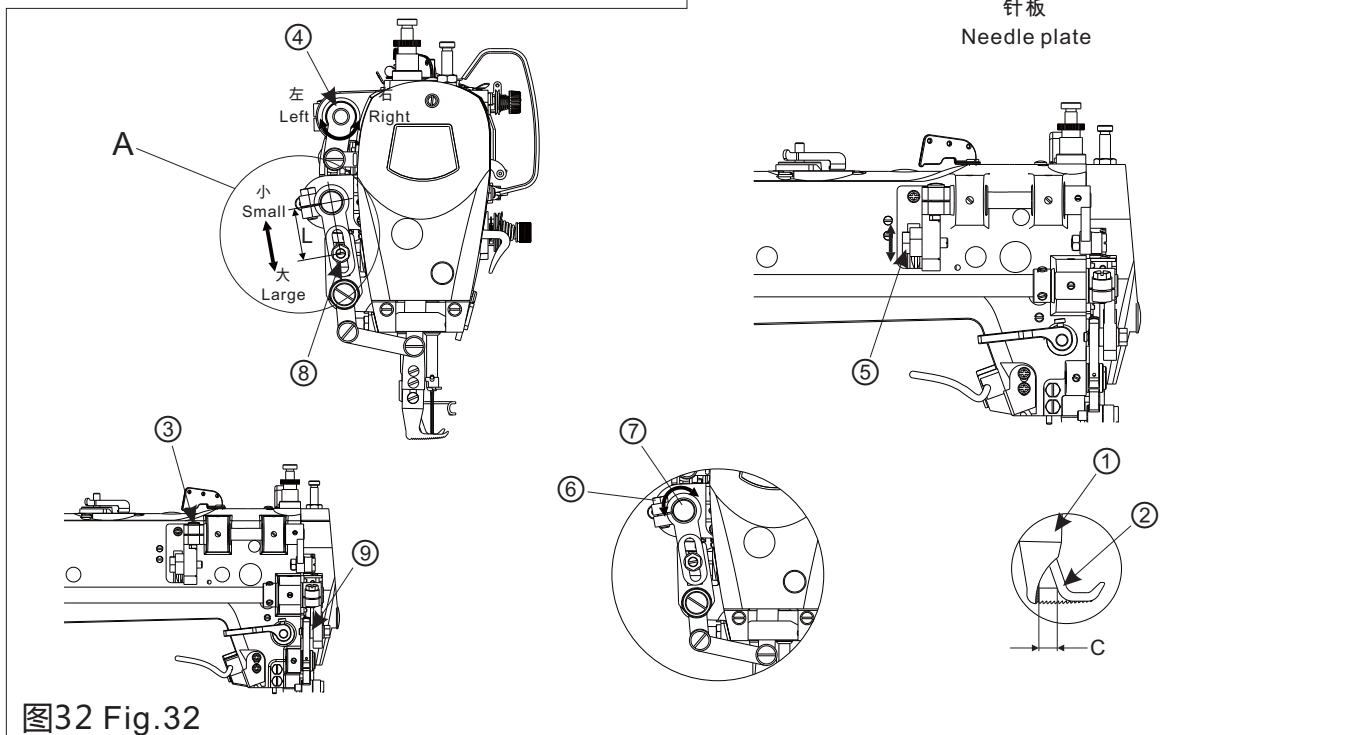

图33 Fig.33

2.定刀片与动刀片的关系 (图34)

1)定刀片①与动刀片②的位置应保证0.3mm。

2)可以如图所示进行调整定刀座或定刀片的位置。

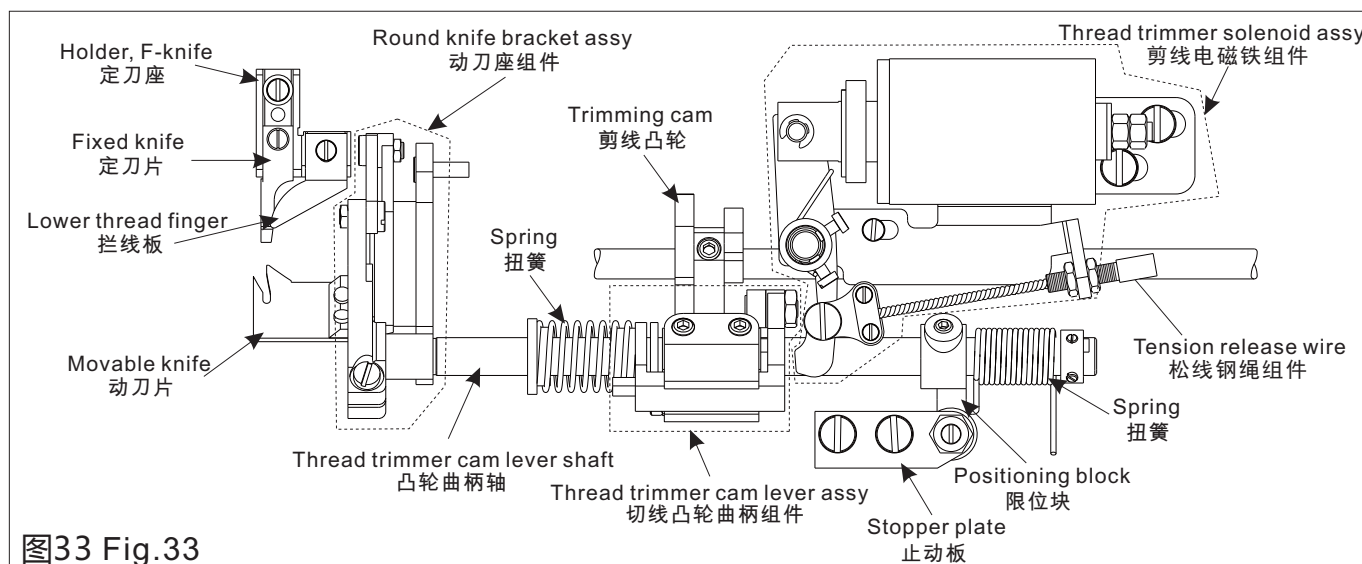
3)移开旋梭定位勾，安装定刀座。



图34 Fig.34

2.The relation between fixed knife and movable knife(Fig.34)

1)The clearance between fixed knife ① and movable knife ② should be 0.3mm

2)Adjust the position illustrated by the Fig.34.

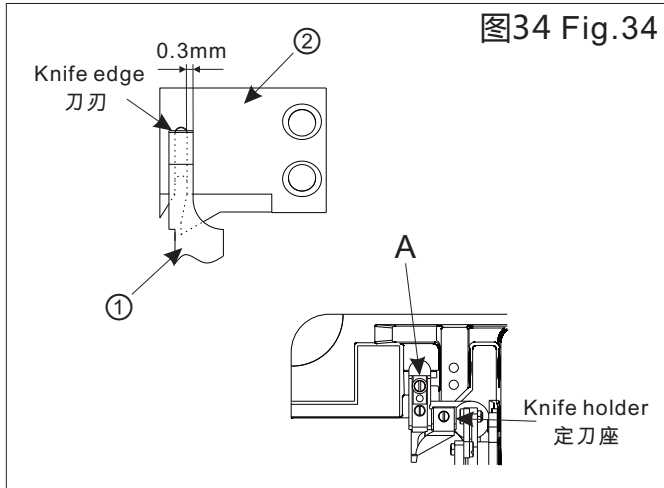
3)Move the bobbin case opener and adjust the holder of fixed knife .



图35 Fig.35

3.凸轮曲柄轴 (图35)

1)装配时，将凸轮曲柄轴①最先装到底板上。

2)切线凸轮曲柄组件必须如图所示安装，固定在凸轮曲柄轴①上的平面处。

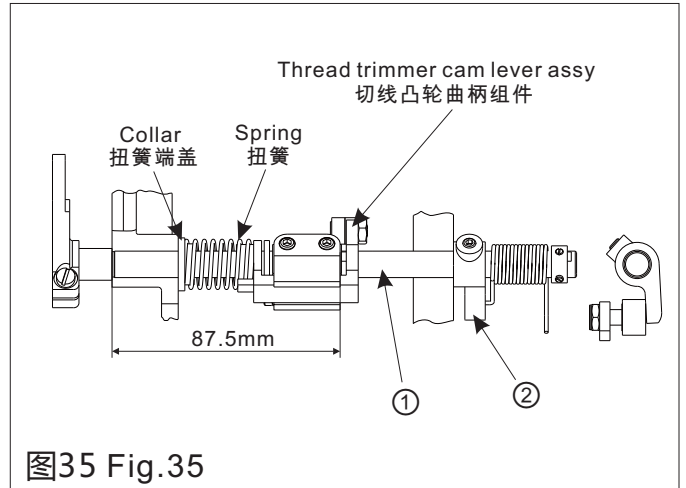
3)轻轻转动凸轮曲柄轴①，将限位块②安装在凸轮曲柄轴①上的平面处。

3.Thread trimmer cam lever shaft(Fig.35)

1)Install the shaft ① on the machine bed first.

2)Install the trimmer cam lever assy on the shaft ① as illustrated.

3)Slightly turn the shaft ①, and install the positioning block ② as illustrated.

4.安装剪线电磁铁 (图36)

1)剪线电磁铁的行程：

a.标准的行程 6.0mm。

b.通过调节螺母A来调整行程。

2)安装剪线电磁铁：

a.剪线电磁铁用螺钉B和C来固定。

b.在安装时必须保证驱动板①与凸轮曲柄②之间的间隙 1mm。

c.电磁铁工作时，凸轮曲柄③与凸轮曲柄②之间会有0.5mm的间隙，这是标准的情况。

如需调整,可以如图36所示箭头方向移动剪线电磁铁。

4.Installing the trimming solenoid(Fig.36)

1)The stroke of solenoid:

a.The standard stroke is 6.0mm.

b.Turn the nut A to adjust the stroke.

2)Install the solenoid

a.Fixed the solenoid by the screws B and C.

b.Be sure to keep the clearance between the driven plate ① and cam lever ② 1mm.

c.When the solenoid is active, there should be a 0.5mm clearance between the cam lever ③ and cam lever ②.

If need to adjust. Please move the solenoid base shown by the arrow.



图36 Fig.36



图37 Fig.37

5.安装剪线凸轮 (图37)

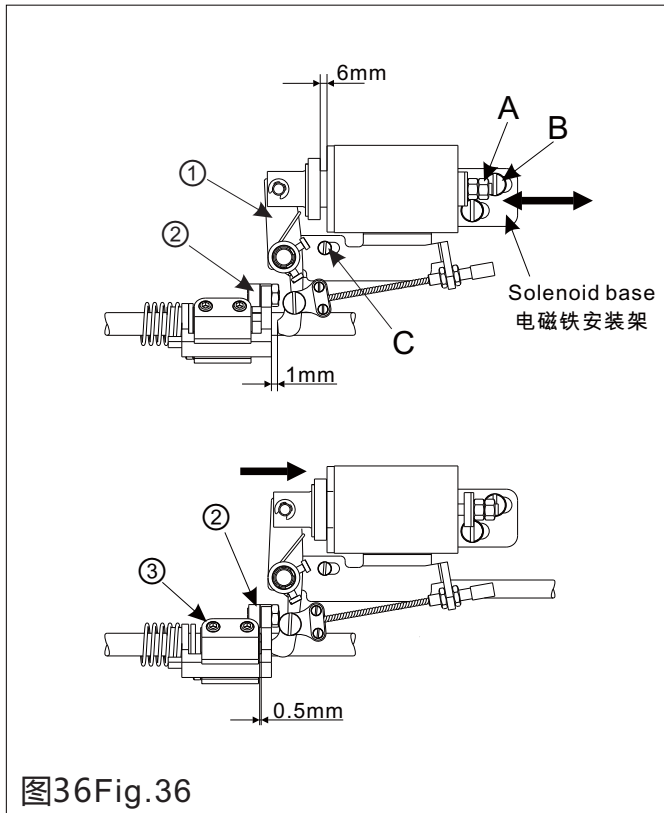
1)转动上轮，使挑线杆处于最高位置。

2)手动打开电磁铁，移动并旋转剪线凸轮①，直到接触凸轮曲柄②的滚柱，然后固定凸轮。

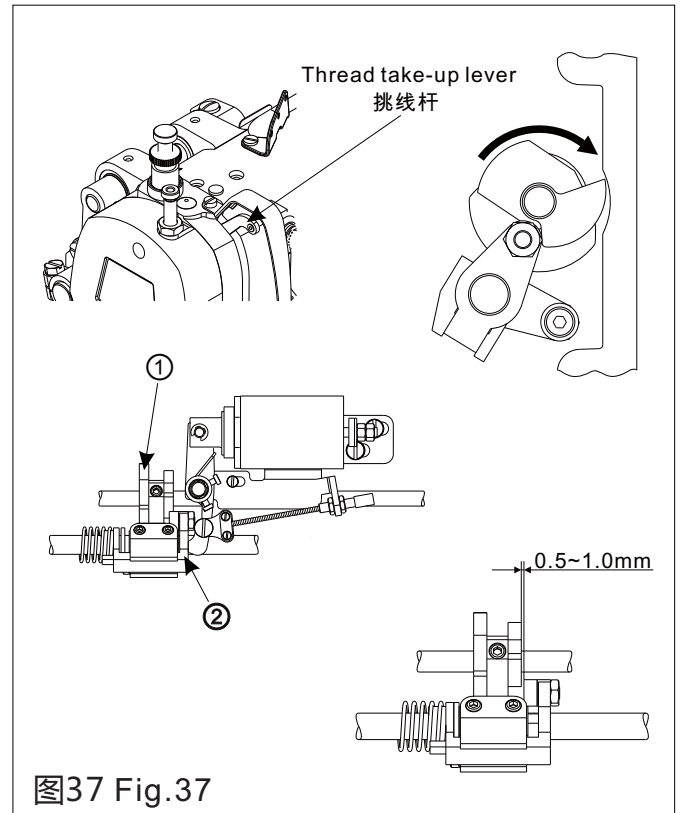
3)关闭电磁铁，使凸轮曲柄②回复到原始位置，这样凸轮①与凸轮曲柄②的滚柱端面会产生0.5~1.0mm的标准间隙。

5. Installing the trimming cam (Fig.37)

1) Turn the wheel, make the thread take-up lever in the highest position.

2) Set the solenoid active, turn the trimming cam ① until the cam is touched with the roller of the cam lever ②, then fix the cam.

3) Set the solenoid inactive and make the lever ② restore to the original position, there should be a 0.5~1.0mm clearance between the cam ① and the roller of the cam lever ②.

6.刀片的调整 (图38)

1)动刀片与定刀片的关系：

如图所示，动刀片①与机针中心的距离 7.5mm，定刀片②与机针中心的距离 5mm。

2)刀片的调整：

开启剪线功能，这样剪线凸轮会使动刀片①向右旋转。当动刀片①转动到其最远位置时，与定刀片②的间隙 1.5-2.0mm。

3)剪线压力的调整：

如果剪线情况不良，尤其当线较粗时，只需增加剪线压力即可。剪线压力如下所述进行调整：

6. Adjusting the knives (Fig.37)

1) The relation between fixed knife and movable knife:

The clearance between movable knife ① and needle center is 7.5mm, and the clearance between fixed knife ② and needle center 5mm.

2) Adjusting the knives

Set the function of trimming thread active, the movable knife ① will turn rightward by the trimming cam. When the movable knife ① moves to its furthest position, the clearance between two knives ① and ② should be 1.5-2.0mm.

3) Adjusting the trimming pressure:

If the thread trimming not smoothly, especially the thick thread used, just need to increase the trimming pressure. The trimming pressure is adjusted as follows: loosen the nut B, adjust the screw A to get the reasonable pressure.

松开螺母B，通过调节螺钉A来增加或减小剪线压力。



图38 Fig.38



图39 Fig.39

28 调节剪线后的线头长度(图32) Adjusting the trailing length after thread trimming(Fig.39)

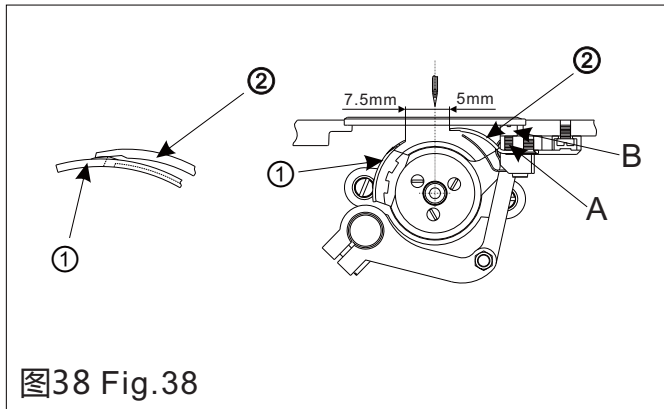
通过转动小夹线螺母①来调节。

在剪线的时候，夹线器松开，面线只有小夹线器提供的张力。标准面线线头的长度 40~70mm。如果小夹线螺母①旋紧，那么面线的线头长度就短；如果小夹线螺母①旋松，那么面线的线头长度就长。

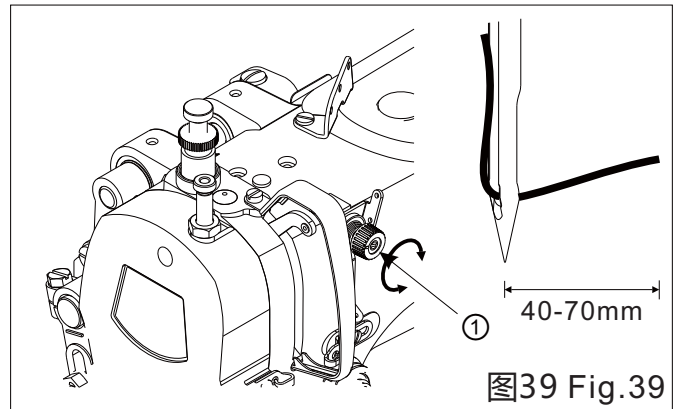
Turn the nut ① to adjust the trailing length.

At the time of thread trimming, the thread tension mechanism will release and the needle thread tension is only applied by the thread ①. The standard trailing length for the needle thread is 40-70mm. If increase the thread guide tension, the trailing length will be short; If decrease the thread guide tension, the trailing length will be longer.

零件手册

PARTS BOOK

目录

CONTENTS

一	机壳部件 Casting Mechanism	25
一	针杆、挑线部件 Needle Bar & Thread Take-up Mechanism	27
三	压脚部件 Presser Foot Mechanism	29
四	送料部件 Feed Mechanism	31
五	上送料部件 Upper Feed Mechanism	35
六	旋梭部件 Hook Mechanism	39
七	供油润滑部件 Lubrication Mechanism	41
八	剪线部件 Thread Trimming Mechanism	43
九	倒缝部件 Peverse Stitching Mechanism	45
十	抬压脚部件 Presser Foot Lift Mechanism	47
十一	附件 Accessories For Model	49

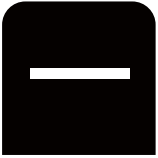

机壳部件
Casting Mechanism

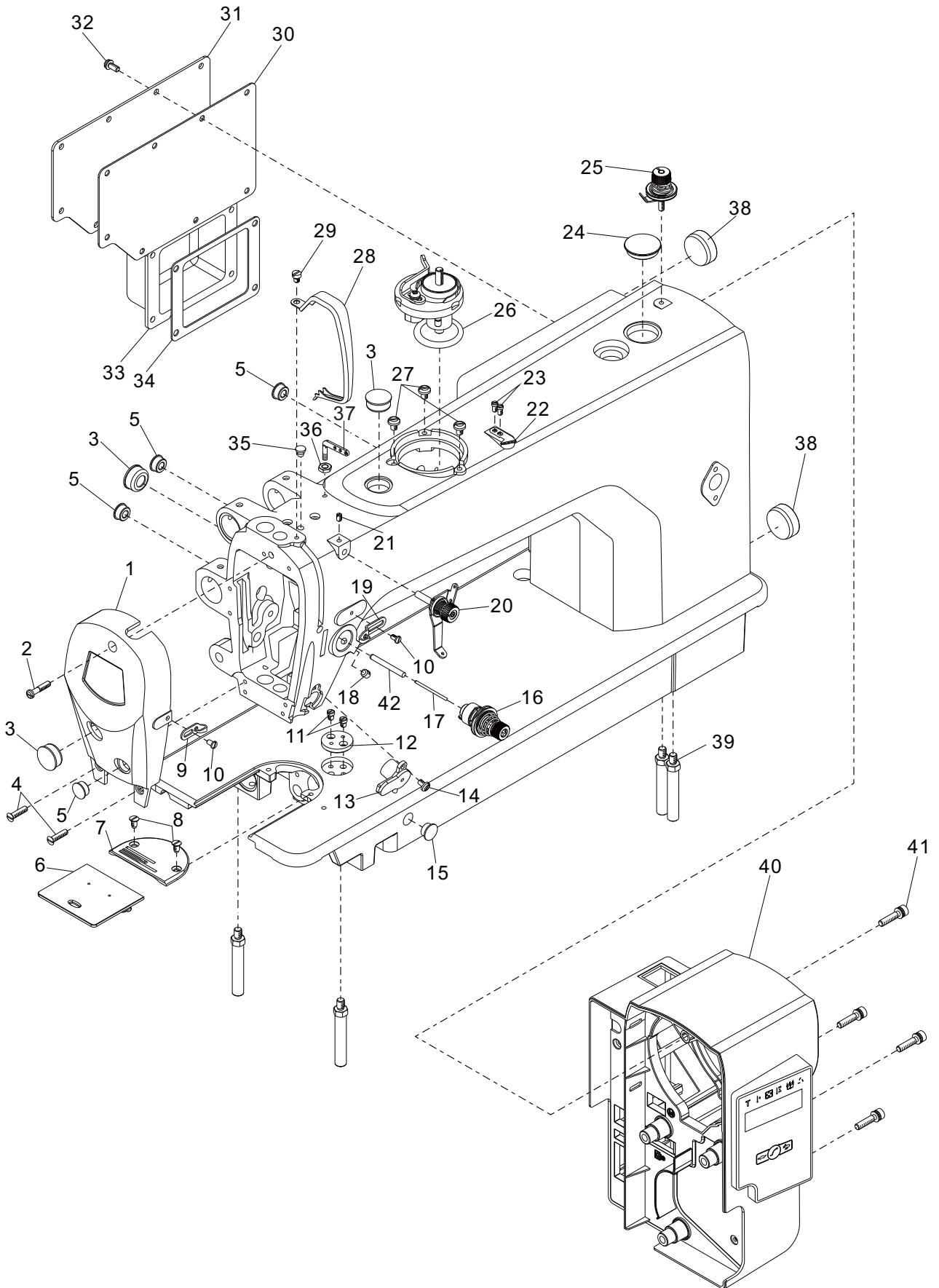

机壳部件
Casting Mechanism

序号 Ref. No.	件号 Part No.	名称	Name of part	数量 QTY	备注 Remark
1	20017920	面板	Face plate	1	
2	10043309	面板螺钉	Screw	1	
3	10043315	面板橡皮塞	Rubber plug	3	
4	10048790	面板螺钉	Screw	2	
5	10013171	橡胶塞	Rubber plug	4	
6	10043597	推板组件	Slid plate assy.	1	
7	10043304	针板	Needle plate	1	适用于普通机型
	10047841	针板	Needle plate	1	适用于-CX机型
8	10043305	针板螺钉	Screw	2	
9	10040996	面板线钩	Thread guide	1	
10	10043312	线钩螺钉	Screw	2	
11	10004374	SM11/64"×40螺钉	Screw SM11/64"×40	2	
12	10004373	限位挡片	Scale base plate	1	
13	10051583	电子夹线器	Bobbin thread tension ASM.	1	适用于-D3机型
	10052840	下过线板	Lower thread-guide	1	适用于-BD机型
14	10010595	M4×7.5螺钉	Screw M4×7.5	1	
15	10049739	橡胶塞	Rubber plug	1	
16	10054478	夹线器组件	Thread tension bracket assy.	1	适用于普通机型
	10051110	夹线器组件	Thread tension bracket assy.	1	适用于-H机型、-CX机型
17	10052339	松线钉	Tension release pin	1	适用于-BD机型
	10051109	松线钉	Tension release pin	1	适用于-D3机型
18	10010678	螺钉	Screw	1	
19	10043594	线钩	Thread guide	1	
20	10052960	上夹线器部件组件	Bobbin thread tension ASM.	1	
21	10045042	固定螺钉	Set screw	2	
22	10011149	绕线切刀	Knife	1	
23	10050423	SM9/64"×40螺钉	Screw SM9/64"×40	1	
24	10045754	橡胶塞	Rubber plug	1	
25	10051431	绕线夹线器组件	Bobbin thread tension	1	
26	10031086	绕线器	Bobbin winder	1	
27	10004380	SM3/16"×32螺钉	Screw SM3/16"×32	1	
28	20019074	挑线杆护罩	Thread take-up lever cover	1	
29	10043360	挑线杆护罩螺钉	Screw	1	
30	10051344	后窗板垫	Side plate gasket	1	
31	20017919	后窗板	Side plate	1	
32	10010030	SM3/16"×32螺钉	Screw	10	
33	20019092	倒缝电磁铁罩	Solenoid cover	1	适用于-BD机型
	20016032	倒缝电磁铁罩	Solenoid cover	1	适用于-D3机型
34	10046248	倒缝电磁铁罩垫片	Washer	1	
35	10043311	橡胶塞	Rubber plug	1	
36	10012620	SM15/64"×28螺母	Nut	1	
37	10013602	三孔线钩	Three-hole thread retainer	1	
38	10043588	橡皮塞(Φ27)	Rubber plug(Φ27)	2	
39	10002577	底板支柱	Screw stud	4	
40	*	一体机电控	Electronics control ASM.	1	
41	10053435	螺钉组件	Screw	4	
42	10046133	挺线钉	Pressure release lead	1	

* 具体内容需向客服咨询

针杆、挑线分组件

Needle Bar & Thread Take-up Mechanism

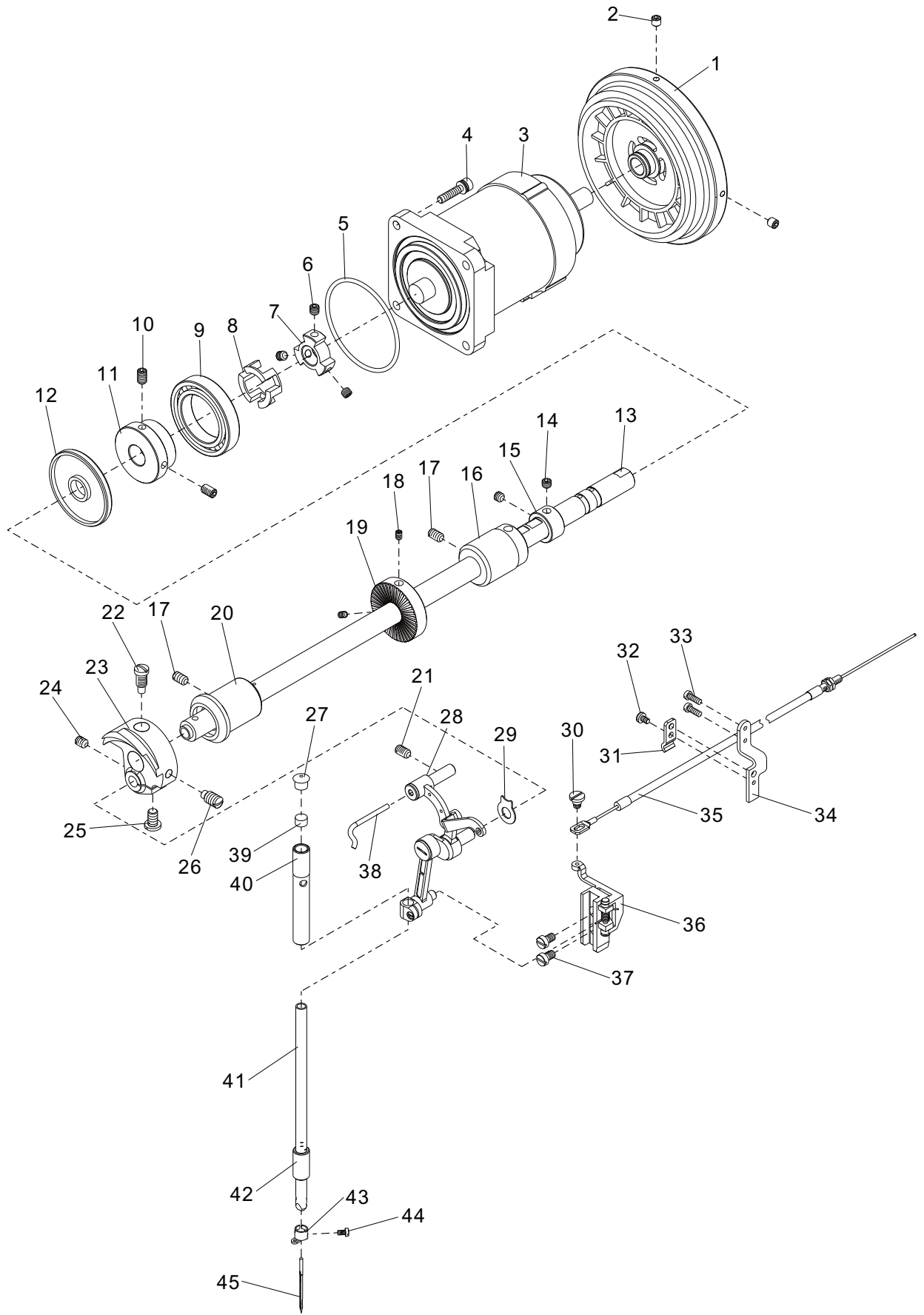

针杆、挑线分组件

Needle Bar & Thread Take-up Mechanism

序号 Ref. No.	件号 Part No.	名称	Name of part	数量 QTY	备注 Remark
1	20019071	上轮	Hand wheel	1	
2	10011232	螺钉	Screw	2	
3	10051093	同步车一体机电机	Motor	1	
4	10006157	螺钉组件	Screw	4	
5	10003796	O形圈	O ring	1	
6	10011232	螺钉M6×6	Screw M6×6	3	
7	10008908	联轴器	Coupling ASM.	1	
8	10008909	联轴器橡胶圈	Washer	1	
9	10024755	6907ZZ-B0M轴承	Bush.R	1	
10	10012161	螺钉M6×0.75×10	Screw M6×0.75×10	2	
11	10046144	上轴联轴器	Connector	1	
12	10008803	油封	Oil seal	1	
13	10051146	上轴	Pper shaft	1	
14	10012162	螺钉M5×5	Screw M5×5	2	
15	10051603	上轴挡圈	Collar	1	
16	10043332	上轴中轴套	Bush.M	1	
17	10010506	螺钉	Screw	2	
18	10045042	绕线器主动轮螺钉	Screw	2	
19	10045041	绕线器主动轮	Screw SM9/32"×28	1	
20	10043335	上轴前轴套	Bush.L	1	
21	10043333	螺钉	Screw	1	
22	10050400	针杆曲柄定位螺钉	Screw	1	
23	10043341	针杆曲柄	Thread take-up crank	1	
24	10043329	伞齿轮螺钉	Screw	1	
25	10043340	挑线曲柄螺钉	Screw	1	
26	10010082	针杆曲柄螺钉	Screw	1	
27	10010587	橡胶塞	Rubber cap	1	
28	10049432	挑线机构	Thread take-up lever set	1	
29	10043357	垫片	Washer	1	
30	10046141	铰链螺钉	Screw	1	适用于-D3机型
31	10046135	松线压板	Wire holder.D	1	适用于-D3机型
32	10013518	软线固定板螺钉	Screw	1	适用于-D3机型
33	10043556	油线固定板螺钉	Screw	2	适用于-D3机型
34	10046150	松线钢绳固定架	Wire holder.U	1	适用于-D3机型
35	10051112	松线钢绳组件	Tension release wire	1	适用于-D3机型
36	10050045	针杆接头滑块导轨组件	Needle bar slider guide rail assembly	1	适用于-D3机型
	10055937	针杆接头滑块导轨	Needle bar slider guide rail	2	适用于-BD机型
37	10043360	针杆接头滑块导轨螺钉	Screw	1	
38	10008062	油线	Oil wick	1	
39	10043375	毛毡	Felt	1	
40	10043362	针杆上轴套	Bush.U	1	
41	10051161	针杆	Needle bar	1	
42	10043365	针杆下轴套	Bush.D	1	
43	10005945	针杆线钩	Thread guide	1	
44	10043367	夹针螺钉	Screw	1	
45	*	机针	Needle	1	

压脚部件
Presser Foot Mechanism

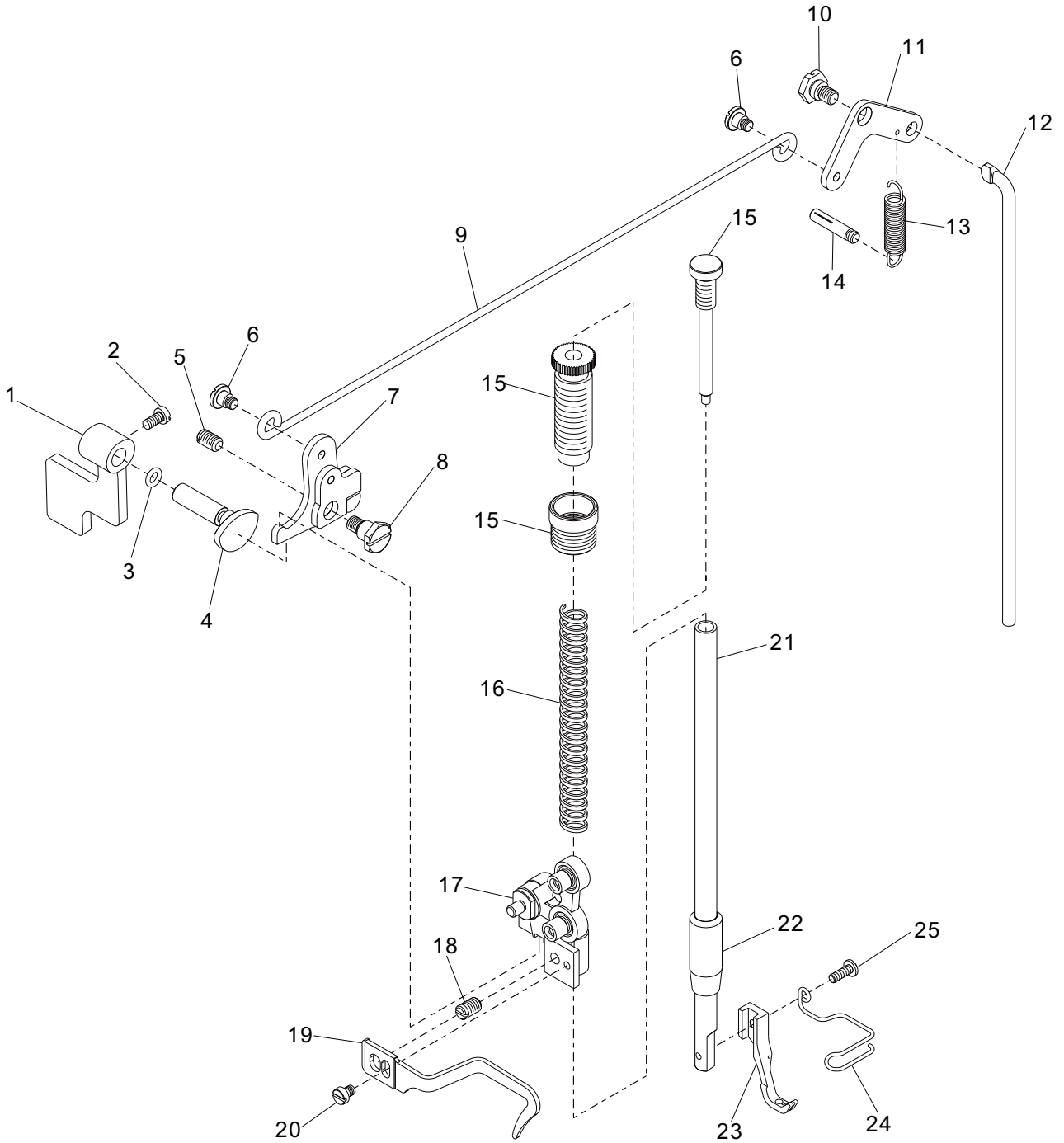

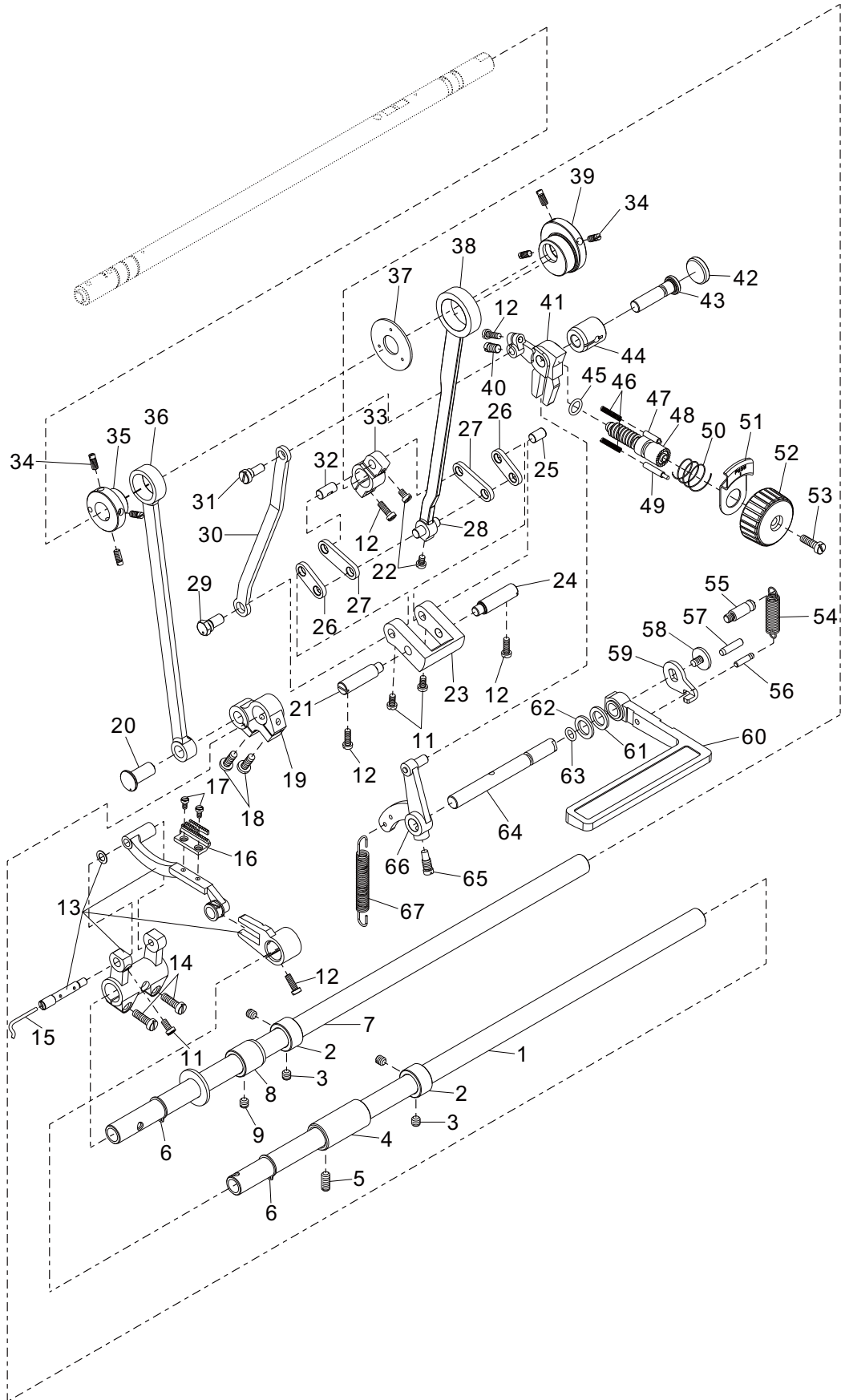

四

送料部件 Feed Mechanism

序号 Ref. No.	件号 Part No.	名称	Name of part	数量 QTY	备注 Remark
1	10051151	抬牙轴	Shaft	1	
2	10043330	上轴紧圈	Collar	2	
3	10023200	螺钉	Screw	4	
4	10044997	轴套	Bush	1	
5	10043398	上轴轴套螺钉	Screw	1	
6	10003290	15挡圈	Retaining ring 15	2	
7	10051149	送料轴	Feed shaft	1	
8	10044998	轴套	Bush	1	
9	10006264	螺钉	Screw	1	
11	10043360	针杆接头滑块导轨螺钉	Screw	3	
12	10043396	抬牙叉夹紧螺钉	Screw	5	
13	10057281	牙架组件	Feed bar	1	
14	10043401	曲柄螺钉	Screw	2	
15	10008067	φ2油线	Oil wick φ2	1	
16	10043410	送布牙	Feed dog	1	适用于普通型、-H型
	10047843	送布牙	Feed dog	1	适用于-CX型
	10048292	送布牙	Feed dog	1	适用于-CX-L型
17	10043411	送布牙螺钉	Screw	2	
18	10046263	曲柄螺钉	Screw	2	
19	10046170	抬牙后曲柄	Feed lifting arm	1	
20	10043403	抬牙轴曲柄铰链轴	Pin	1	
21	10051102	针距调节曲柄左定位销	Pin shaft.L	1	
22	10043415	曲柄连杆短销螺钉	Set screw	2	
23	10051163	针距调节曲柄	Feed regulator crank	1	
24	10043438	针距调节曲柄定位销(右)	Pin shaft.R	1	
25	10052651	连杆销	Shaft	1	
26	10043434	曲柄短连杆	Link	2	
27	10043433	曲柄长连杆	Link	2	
28	10043432	曲柄连杆长销	Stud	1	
29	10051145	连杆偏心轴	Shaft	1	
30	10051162	针距调节连杆	Connecting rod	1	
31	10043421	针距调节连杆销钉	Connecting stud	1	
32	10043416	曲柄连杆短销	Stud	1	
33	10043414	送布轴曲柄(右)	Feed rocker arm	1	
34	10043378	抬牙凸轮螺钉	Screw	6	
35	10043379	抬牙凸轮	Eccentric wheel	1	
36	10051150	抬牙连杆	Feed lifting rod	1	
37	10043376	凸轮隔离片	Holder	1	
38	10051148	送布连杆	Feed connecting rod	1	
39	10043429	送布凸轮	Feed cam	1	
40	10043445	针距座短螺钉	Screw.S	1	
41	10046168	针距座	Feed regulator	1	
42	10043451	橡皮塞(φ20)	Rubber cap	1	
43	10045098	针距座轴	Shaft	1	

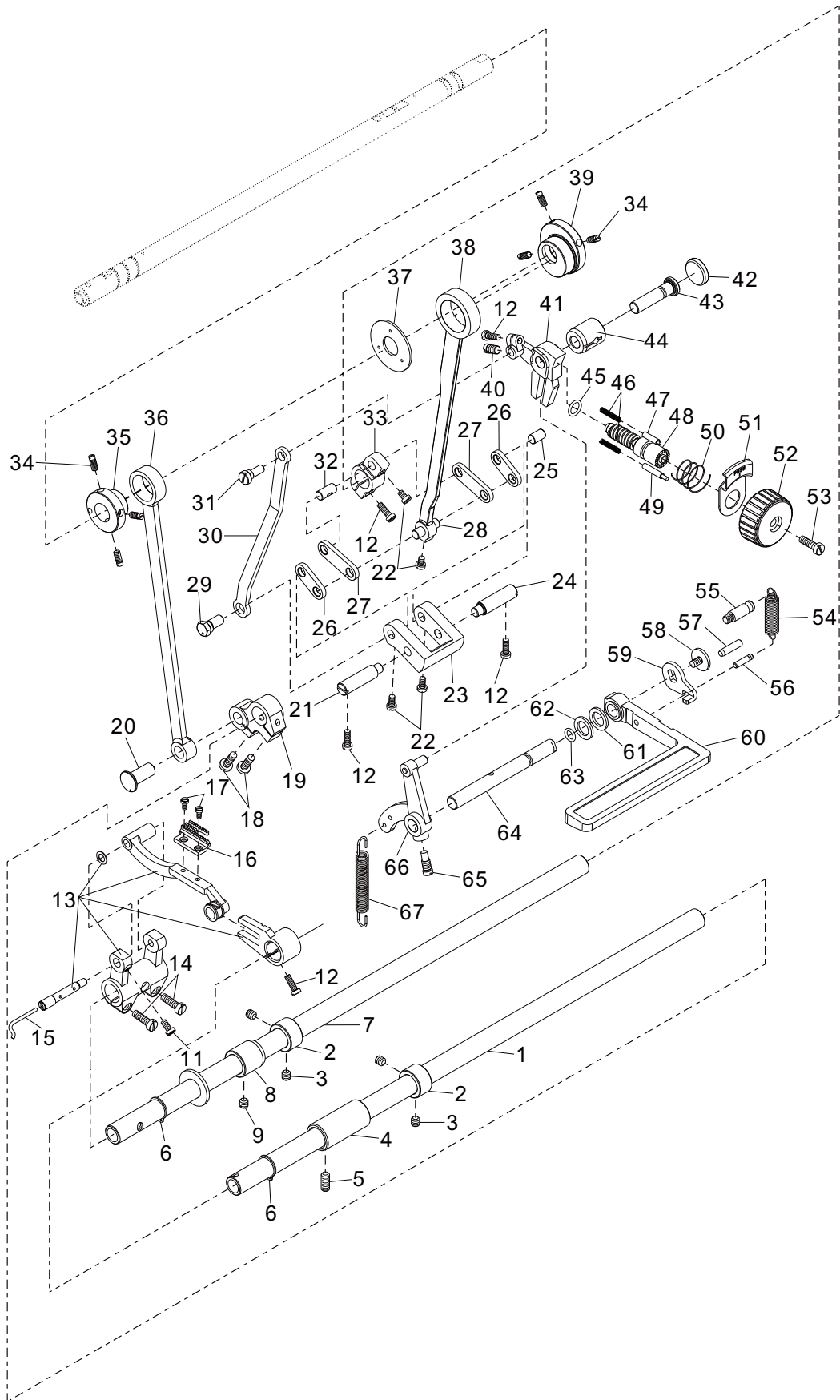



上送料部件
Upper Feed Mechanism

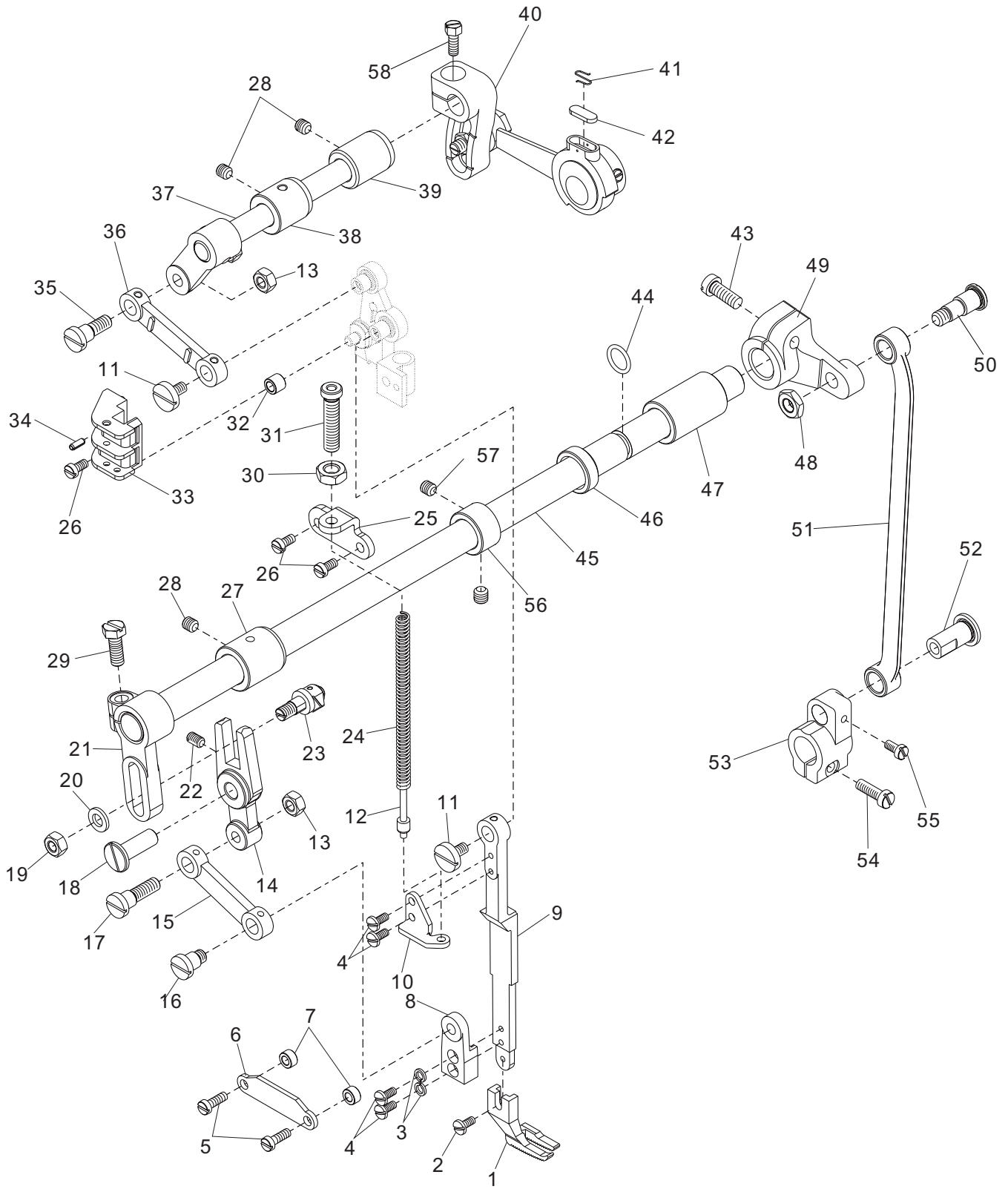

序号 Ref. No.	件号 Part No.	名称	Name of part	数量 QTY	备注 Remark
1	10043506	摆压脚	Waking foot	1	
2	10043507	压脚螺钉	Screw	1	
3	10002991	4垫圈	Washer 4	2	
4	10010018	SM9/64"×40螺钉	Screw SM9/64"×40	4	
5	10043396	拾牙叉夹紧螺钉	Screw	2	
6	10051152	提升压脚连杆压板	Rod guide	1	
7	10043505	压脚连杆压脚垫块	Collar	2	
8	10043503	摆压脚杆座	Clamper	1	
9	10051142	摆压脚杆	Connecting rod	1	
10	10043490	提升压脚导柱定位板	Holder plate	1	
11	10043512	压脚送料曲柄螺钉	Screw	2	
12	10043530	调压杆弹簧导柱	Guide shaft	1	
13	10043500	压脚送料变动连接螺母	Nut	1	
14	10051140	摆压脚叉形杆	Lever	1	
15	10051143	摆压脚连杆	Link	1	
16	10043502	压脚送料曲柄连杆螺钉	Screw	1	
17	10043498	压脚送料变动连接螺钉	Screw	1	
18	10043496	摆压脚叉形杆销	Shaft	1	
19	10043494	压脚曲柄连接螺母	Nut	1	
20	10003086	6垫圈	Washer 6	1	
21	10051156	压脚摆动前曲柄	Crank	1	
22	10026903	螺钉	Screw	1	
23	10049434	提升压脚变动曲柄轴组件	Roller shaft assy	1	
24	10053479	摆压脚调压弹簧	Compression spring	2	
25	10051602	摆压脚调节螺钉架	Bracket	1	
26	10043360	针杆接头滑块导轨螺钉	Screw	4	
27	10051159	压脚摆动轴前轴套	Bush.L	1	
28	10006264	夹线调节座固定螺钉	Screw	3	
29	10046185	前曲柄螺钉	Screw	1	
30	10043486	摆压脚调压螺母	Nut	1	
31	10043526	摆压脚调压螺钉	Screw	1	
32	10043509	提升压脚导柱轴滚柱	Roller	1	
33	10043508	提升压脚导位板	Lever guide	1	
34	10007861	3×8销	Pin 3×8	2	
35	10043513	压脚送料曲柄连杆螺钉(长)	Screw	1	
36	10043511	压脚送料曲柄连杆	Link	1	
37	10049435	压脚升降轴组件	Feed lifting shaft assy	1	
38	10043516	摆压脚提升轴套	Bush	1	
39	10051144	摆压脚提升后轴套	Bush.R	1	
40	10049433	压脚升降偏心轮机构	Eccentric wheel mechanism	1	适用于普通机型、-H机型
	10049701	压脚升降偏心轮机构	Eccentric wheel mechanism	1	适用于-CX机型
41	10043524	油毡簧	Spring	1	
42	10043523	油毡	Oil felt	1	

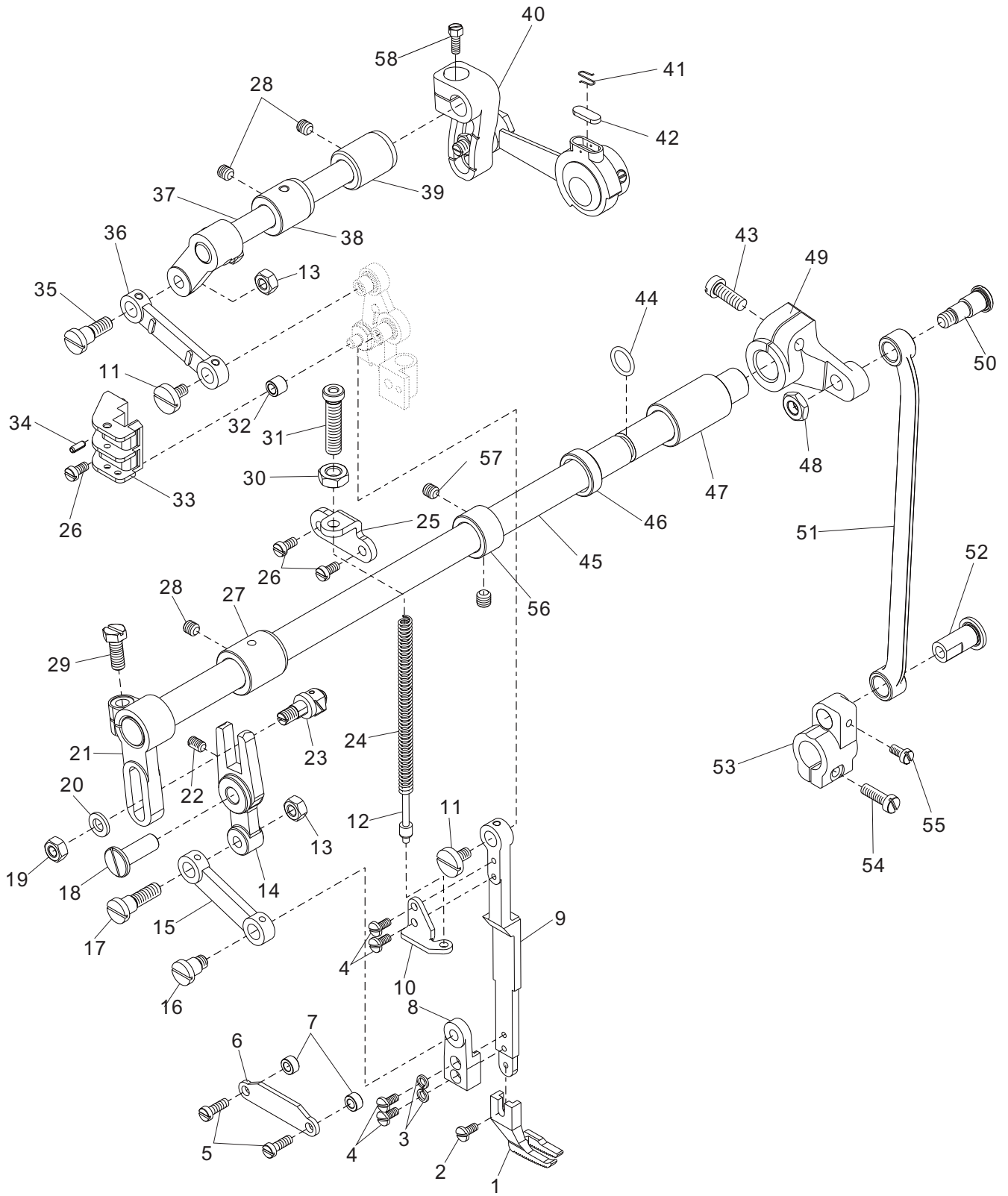



旋梭部件
Hook Mechanism

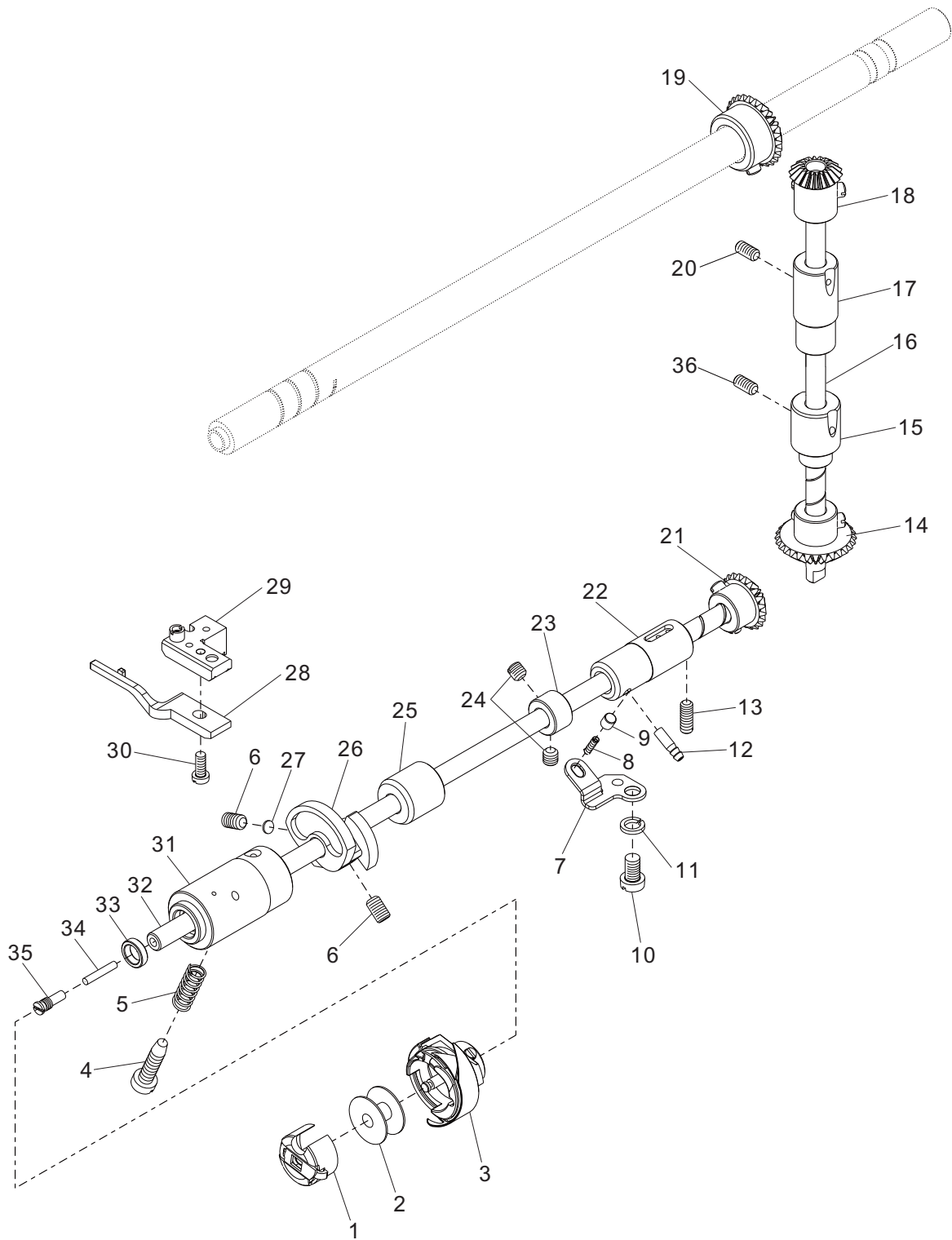



旋梭部件
Hook Mechanism

序号 Ref. No.	件号 Part No.	名称	Name of part	数量 QTY	备注 Remark
1	10007390	GN140-8(90-5)梭子	Bobbin case	1	适用于所有-BD机型
1	10031867	BC-DBM(1)-NBL3梭壳	Bobbin case	1	适用于所有-D3、-D4机型
2	10007138	梭芯	Bobbin	1	
3	10007008	GN141-8(90-5)旋梭	Hook assy	1	适用于-BD机型
3	10039876	德鹰牌_DSH2-B(Q)TR旋梭	Hook assy	1	适用于-D3机型
3	10053025	德鹰牌_DSH2-A1(6-7)旋梭	Hook assy	1	适用于-H-BD机型
3	10031625	德鹰牌_DSH2-ATR_10旋梭	Hook assy	1	适用于-H-D3机型
3	10051236	旋梭_DSH2-GC(6-10)	Hook assy	1	适用于-CX-BD、-CX-L-BD机型
3	10053026	DSH2-GC6-10(TR)旋梭	Hook assy	1	适用于-CX-D3机型
4	10043390	油量调节螺钉	Adjusting screw.OIL	1	
5	10043389	油量调节弹簧	Adjusting spring	1	
6	10046048	剪线凸轮紧定螺钉	Screw	2	适用于-D3机型
7	10043417	挡板	Holder plate	1	
8	10043418	柱塞弹簧	Spring	1	
9	10043419	柱塞	Plunger	1	
10	10044609	导向架拉簧螺钉(上)	Screw	1	
11	10003077	6垫圈	Washer 6	1	
12	10043382	下轴轴套油管	Oil tube	1	
13	10043398	上轴轴套螺钉	Screw	1	
14	10043373	竖轴伞齿轮(下)	Bevel gear.vertrical shaft.L	1	
15	10046154	竖轴轴套(下)	Bush.vertical shaft.L	1	
16	10051147	竖轴	Vertical shaft	1	
17	10046151	竖轴轴套(上)	Bush.vertical shaft.U	1	
18	10043368	竖轴伞齿轮(上)	Bevel gear.vertrical shaft.U	1	
19	10043328	上轴伞齿轮	Bevel gear.upper shaft	1	
20	10010506	SM15/64"×28螺钉	Screw SM15/64"×28	2	
21	10043374	下轴伞齿轮	Bevel gear.lower shaft	1	
22	10043381	下轴后轴套	Bush.lower shaft.R	1	
23	10043402	下轴紧圈	Collar	1	
24	10043412	下轴紧圈螺钉	Screw	2	
25	10046152	下轴中轴套	Bush.lower shaft.M	1	
26	10046243	剪线凸轮	Trimmer driving cam	1	适用于-D3机型
27	10023739	剪线凸轮垫	Holder plate	1	适用于-D3机型
28	10031256	旋梭定位勾	B/case holder position bracket	1	适用于普通机型
	10053402	旋梭定位勾	B/case holder position bracket	1	适用于-H机型、-CX机型
29	10057279	定刀座	Holder f-knife	1	适用于-D3机型
	10050664	定刀座	Holder f-knife	1	适用于-BD机型
30	10043405	旋梭定位勾螺钉	Screw	1	
31	10046156	下轴前轴套	Bush.lower shaft.L	1	
32	10051155	下轴	Lower shaft	1	
33	10046153	下轴油封	Oil seal	1	
34	10010063	油芯	Filter	1	
35	10010064	SM3/16"×32螺钉	Screw SM3/16"×32	1	
36	10013538	SM15/64"×28螺钉	Screw SM15/64"×28	1	

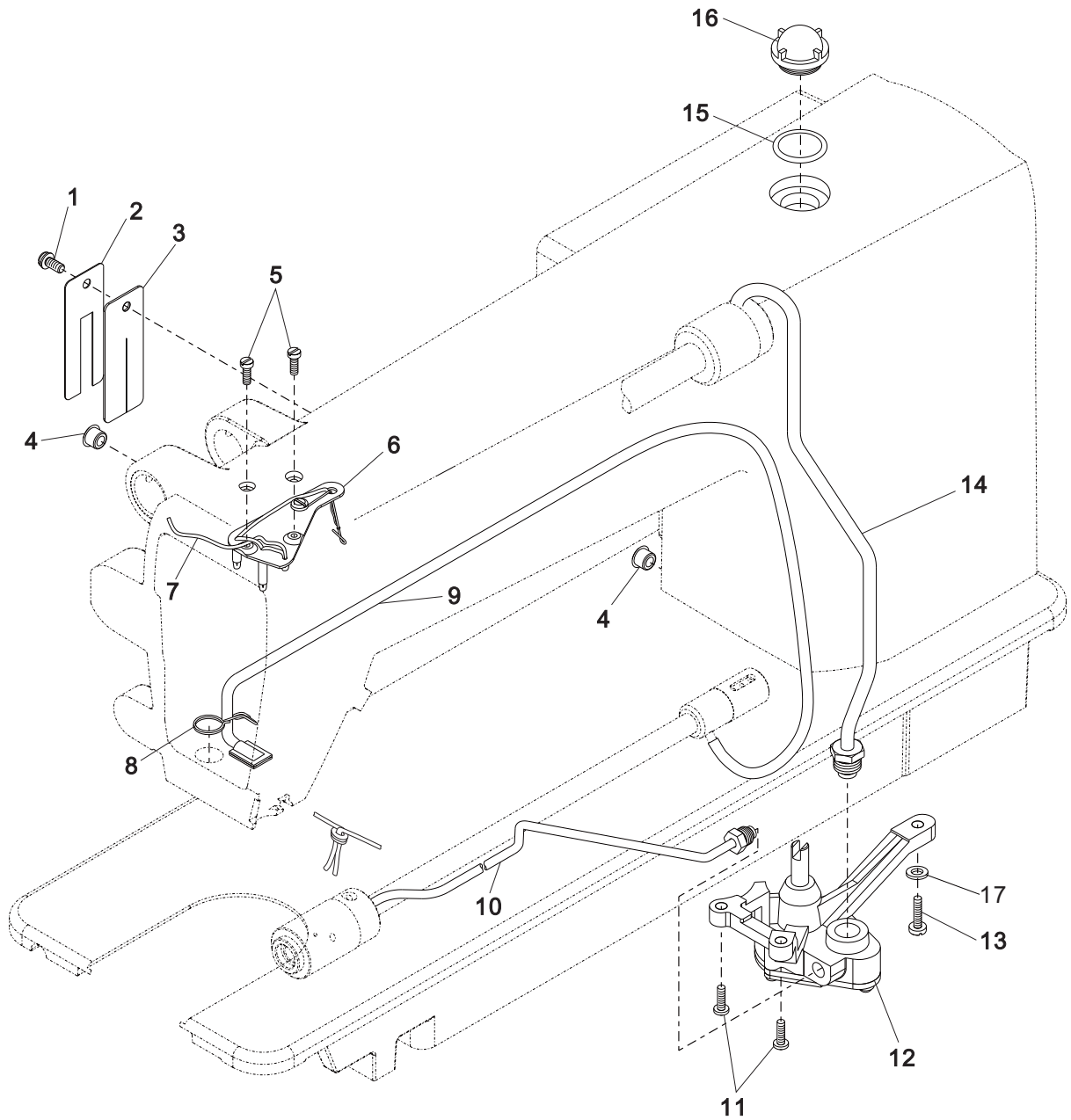

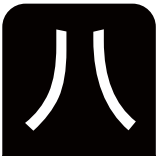

剪线部件
Thread Trimming Mechanism

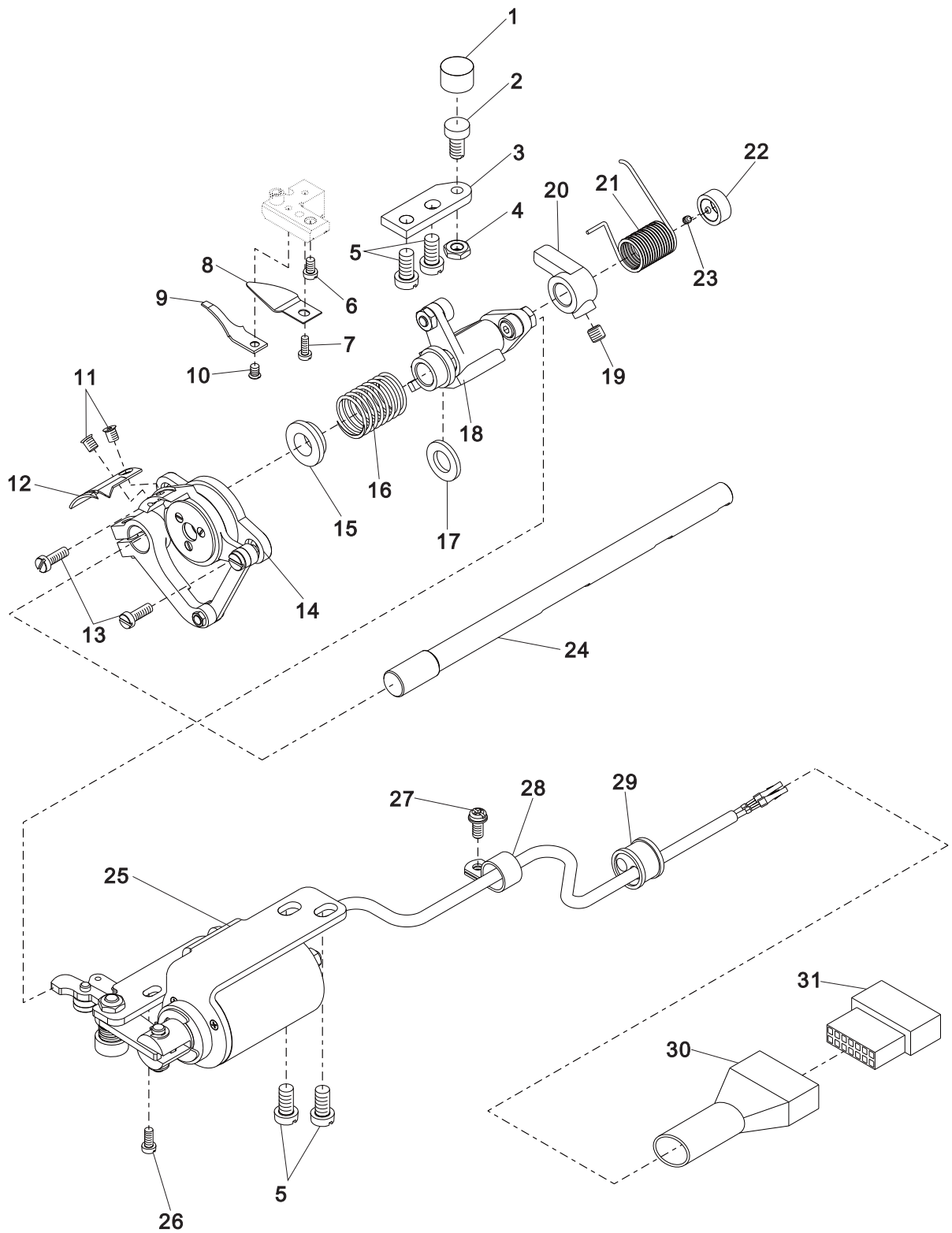

九

倒缝部件

Peverse Stitching Mechanism

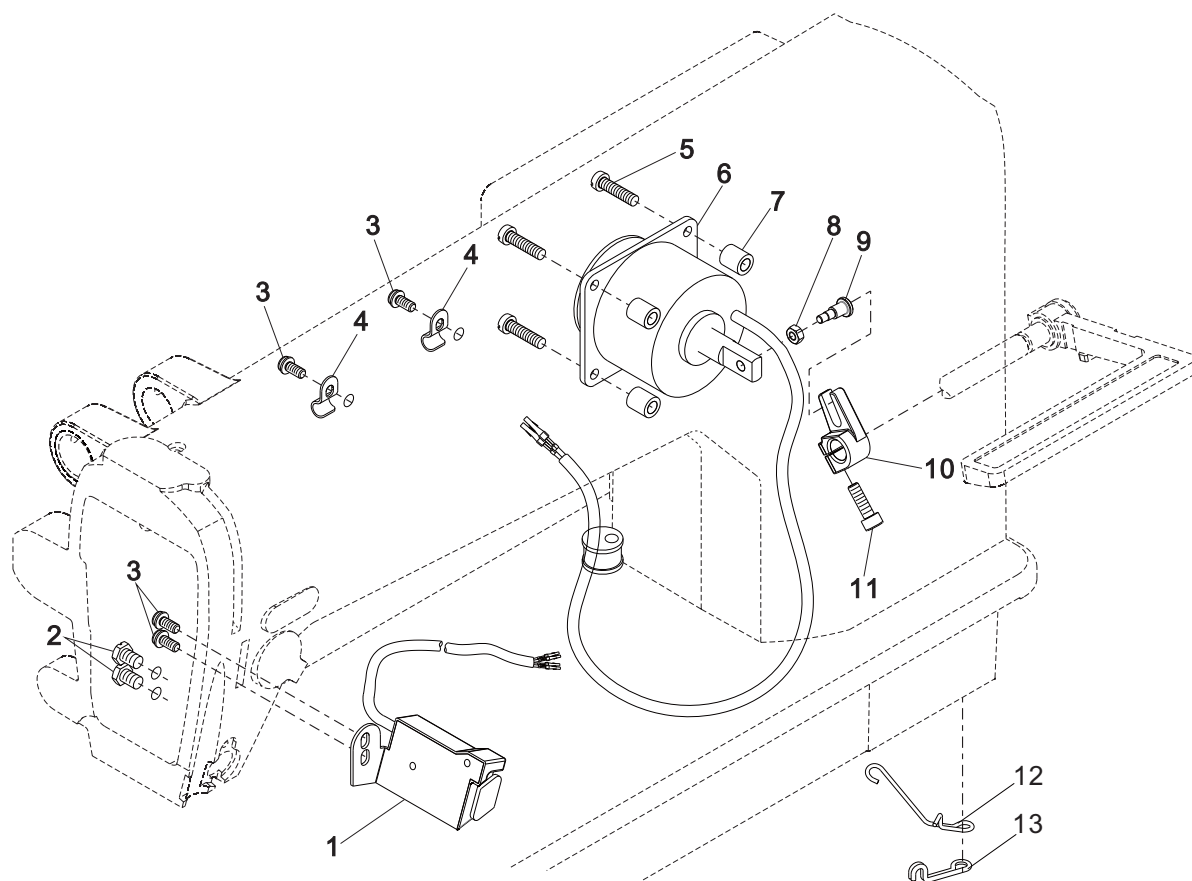



抬压脚部件
Presser Foot Lift Mechanism

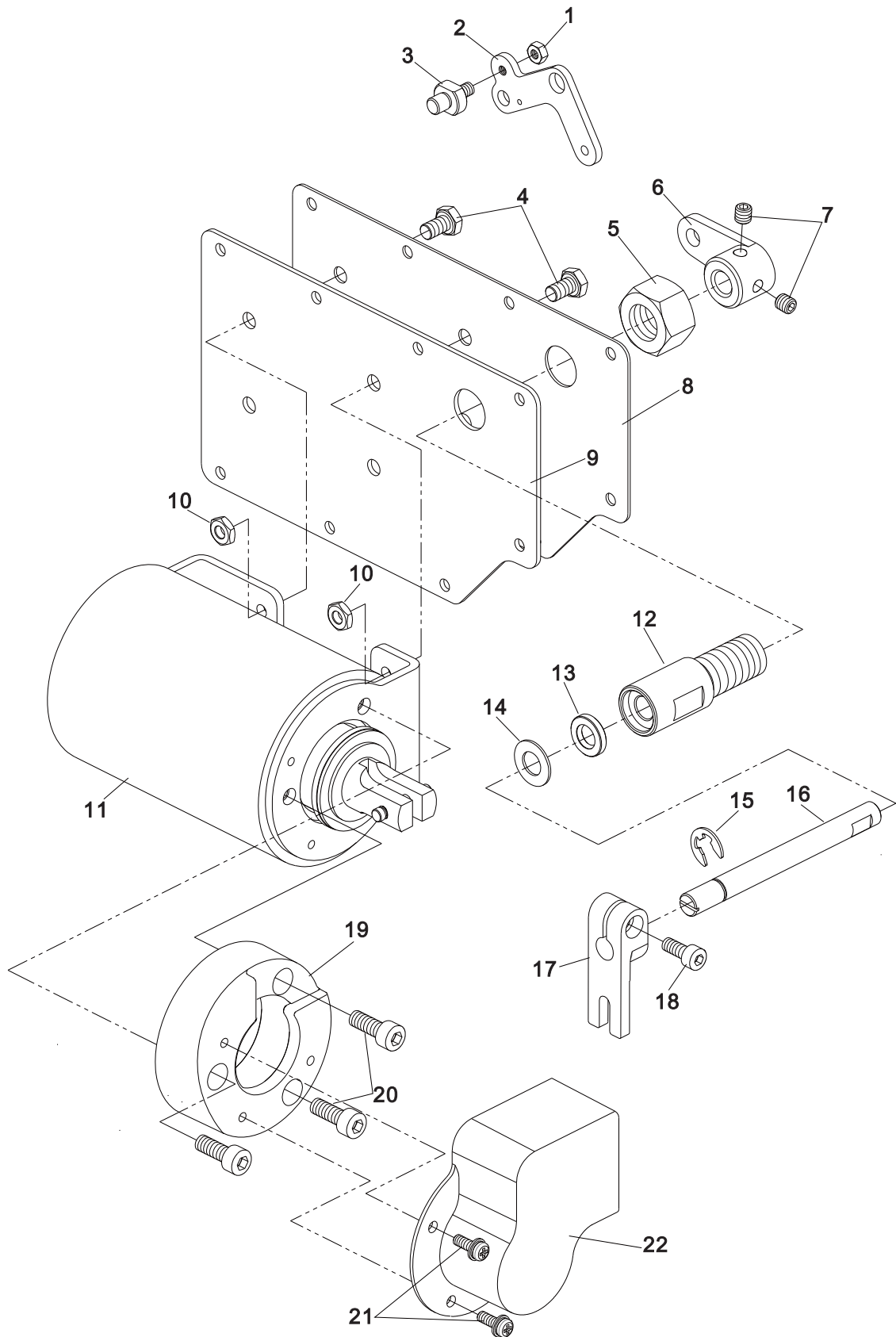

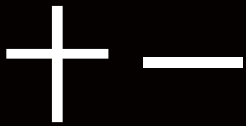

附件
Accessories For Model

