

AIRCYCLER® WIRING for adding a booster fan USING A FANCONNECT SWITCH

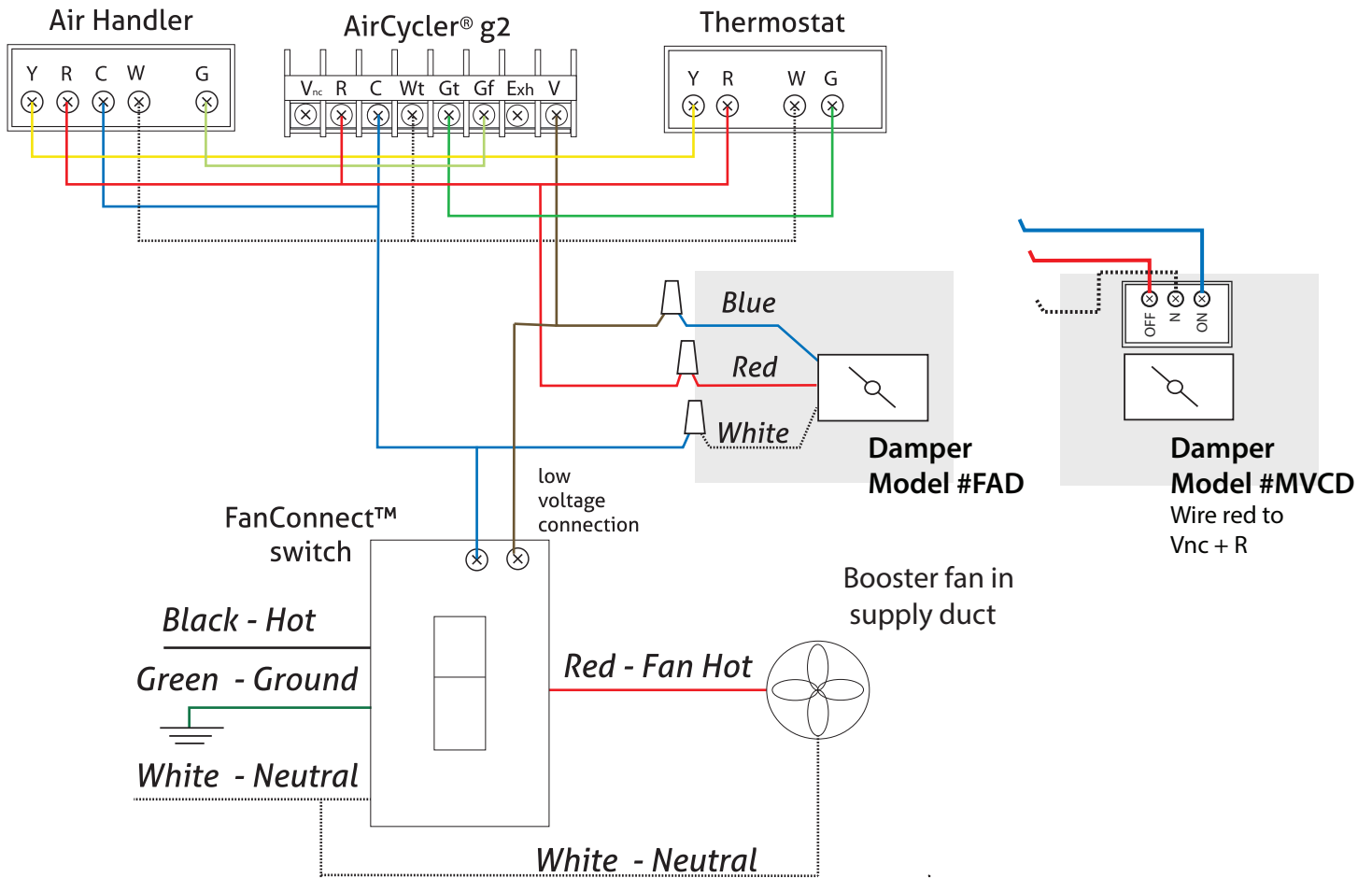

Booster fan will come on anytime damper is open.

KEY
R - 24VAC Power
C - Common
W - Heating
Gt - Fan From Thermostat
Gf - Fan To Furnace
V - Vent
Ex - Exhaust Fan
Vnc - Normal Closed Vent (To power spring-return dampers that are normally open)