



AirCycler® g1

Installation & User's Guide

VENTILATION MADE BREEZY!™
a breeze to install • a breeze to use

INTRODUCTION

If the AirCycler® g1 was installed in your home as a ventilation controller, turning off or otherwise disabling the controller could result in under ventilating your home and could adversely impact indoor air quality.

In the past, homes depended on natural leaks for ventilation. Today, energy efficient homes are built to reduce natural ventilation and leaks. Inadequate ventilation can cause indoor air pollutants to rise to harmful levels. Indoor air quality is typically 5 to 10 times more polluted than outside air. Controlled ventilation systems like the AirCycler® g1 provide adequate air flow to the home without compromising its efficiency.

The AirCycler® g1 is integrated with the home's HVAC system. When the home's furnace fan is turned on by the thermostat to provide heating or cooling, the AirCycler® g1 controller opens a motorized damper to let in a measured amount of fresh air. The fresh air is filtered by the return plenum filter and is then distributed uniformly throughout the home through the existing ductwork. Once the ventilation requirements are met, the damper is closed to prevent over-ventilation. If there are not enough heating or cooling calls to meet ventilation requirements for the hour the AirCycler® g1 will turn on the furnace fan and open the motorized damper until requirements have been met.

SAFETY CONSIDERATIONS

Read and follow manufacturer's instructions carefully. Follow all local electrical codes during installation. All wiring must conform to local and national electrical codes. Improper wiring or installation may result in personal injury or product and property damage.

INSTALLATION CONSIDERATIONS

The AirCycler® g1 requires 24VAC (R and C terminals) to be connected for proper operation. The controller will not operate without these two connections.

The wires (R, C, & W) from the air handler to the thermostat can run parallel with the wiring from the AirCycler® g1 to the air handler. The fan wire (G) must be interrupted by the AirCycler® g1. Some thermostats do not require a common (C) connection. The AirCycler® g1 requires this for power, which must be wired to the furnace.

BATTERY (MODEL CR1220)

The AirCycler® g1 is equipped with a real time battery backed-up clock for use with the Operation Hours setting ONLY. If not setting the hours of operation, the included battery is not required. All other settings are saved in nonvolatile memory.

RECORD ALL SETTINGS ON THE INSTALL STICKER PROVIDED. LIMITED WARRANTY WILL BE VOID IF THE STICKER IS NOT PRESENT.

WIRING DIAGRAM

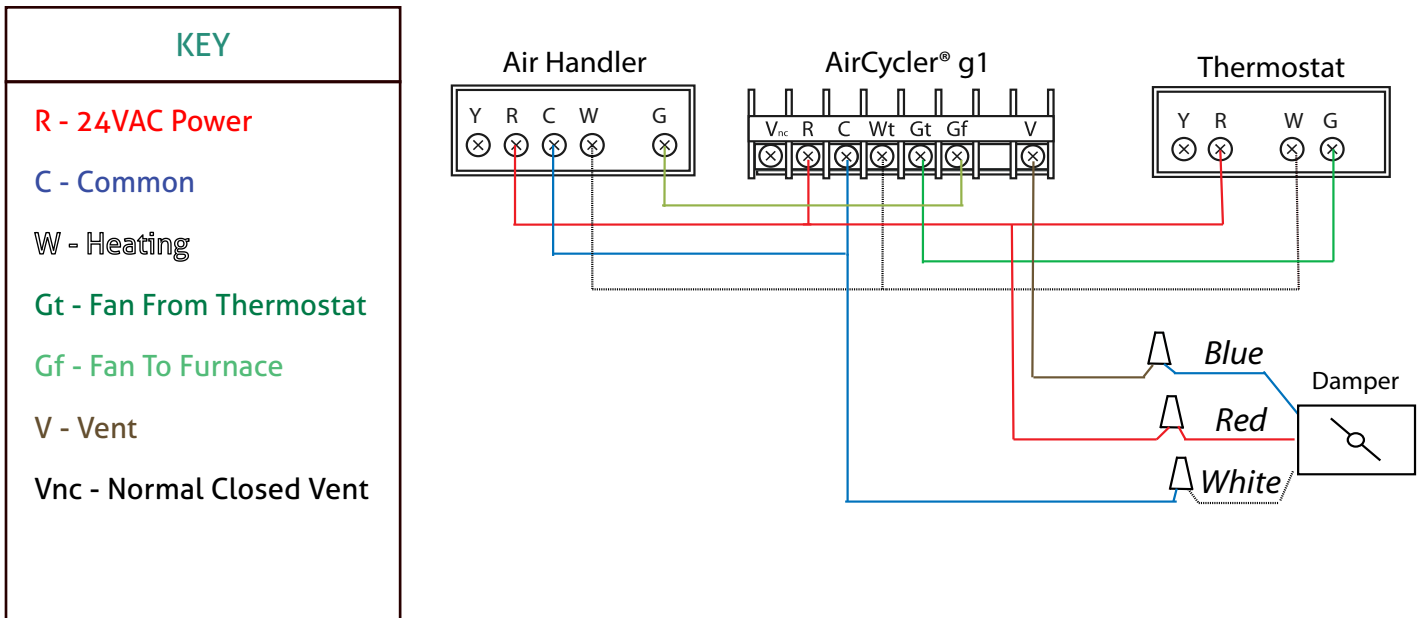

SELECTING YOUR COMPONENT EQUIPMENT

AIR HANDLER

The 2012 IECC requires the central blower used with the AirCycler® g1 to use an electronically commutated motor.

DAMPER LOCATION

The fresh air damper can be located anywhere in the inlet duct. Minimize the length of the inlet duct to improve air flow and improve system efficiency. It is recommended that the damper be as close to the return air plenum and the AirCycler® g1 controller as possible, and the inlet duct connect to the return plenum upstream of the system filter, and down- stream of any duct mounted sensors.

DAMPER INSTALLATION

The damper may be installed in any position. It is recommended to install it with the motor at the 12 o'clock position if mounted horizontally. Air may flow through in either direction, although it is recommended to install with the crimped end as the outlet. Use care to avoid distorting the damper housing and provide adequate support. **Upon system start up be sure to set damper power switch to UP or AUTOMATIC position.**

CHOOSE A FRESH AIR LOCATION

ASHRAE recommends that the fresh air intake be located at least 10 ft. from any source of pollutants, such as auto exhaust, dryer exhaust, exhaust from any fuel-burning appliances, etc. Avoid installation near odor sources such as garbage bins or barbecue grills. A minimum of 3 ft. above ground is recommended to avoiding ingress of leaf litter, grass clippings, etc. Do not use a crawl space, basement, or attic as a source of intake air. Always be sure to comply with local building codes and requirements regarding fresh air inlets.

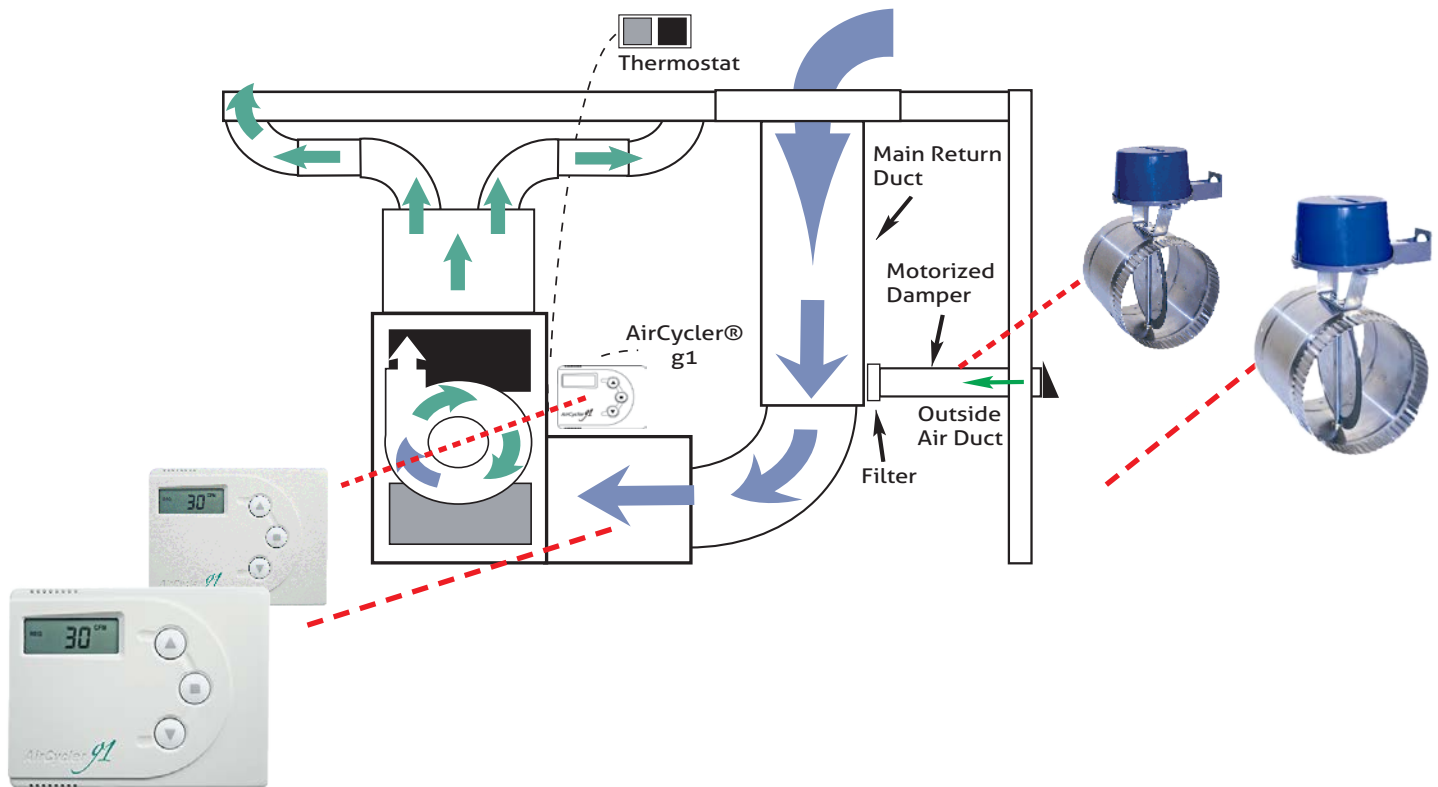

1.0 INSTALLATION & CONFIGURATION INSTRUCTIONS

1.1 AIRCYCLER® G1 CONTROLLER LOCATION

The AirCycler® g1 controller can be installed near the thermostat or out of view on/near the air handler unit.

Warning: Before installing the AirCycler®, turn off all power to the furnace. There may be more than one power to disconnect. Electrical shock can cause injury or death.

1.2 CONFIGURING THE AIRCYCLER G1®

On power up, all icons will be illuminated for 3 seconds.

There are two set up methods: Calculated Flow and Calculated Time. If you know the amount of fresh air coming into the air handler as well as flow required by code you can use Calculated Flow to meet requirements. If you prefer to configure the amount of time you want fresh air to enter the home per hour, use Calculated Time.

To set up the AirCycler® g1 based on **Calculated Flow** press and hold the **UP** arrow for 10 seconds.

To set up the AirCycler® g1 based on **Calculated Time** press and hold the **DOWN** arrow for 10 seconds.

G1 OPERATION & DISPLAY

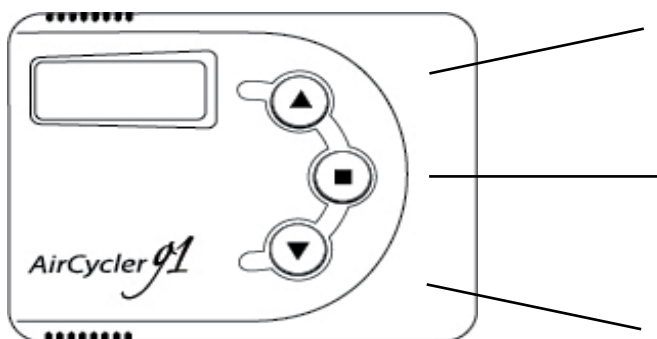

UP ARROW

Use as directed during set up.
During Normal Operation, use to view current status

MODE BUTTON

Use as directed during set up.
During Normal Operation, use to cycle through current time of day

DOWN ARROW

Use as directed during set up.
During Normal Operation, use to view current settings

OPERATING MODE DISPLAY

When the AirCycler® is in Normal Operation, the display will show the percentage of ventilation complete for the current hour.

If the outside fresh air damper is open the OA icon will show.

If the thermostat is calling for heat or cool, the FAN icon will be illuminated **without** the ON icon.

If the central fan is on, the FAN and ON icons will show. The ON icon is only illuminated when the AirCycler® g1 has forced the central fan on.

Pressing the MODE button at any time during normal operation will go to setting the current time of day.

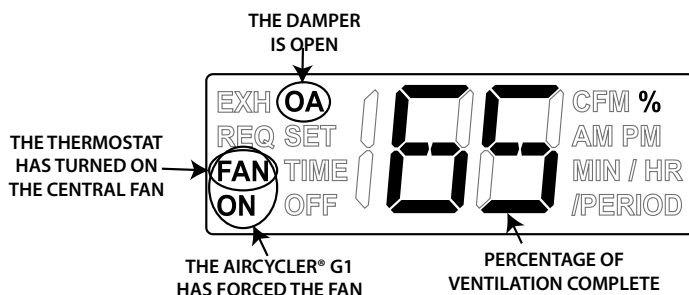

2.0 CALCULATED FLOW SET UP

2.1 SETTING MEASURED SUPPLY AIR FLOW

The measured flow is the amount of air that enters the return side of the air handler from the outside air vent. Enter the measured flow. To accommodate variable speed air handlers, you can enter different values for heat, cool and fan. Factory default is 90 CFM.

Press MODE to advance to the next setting.

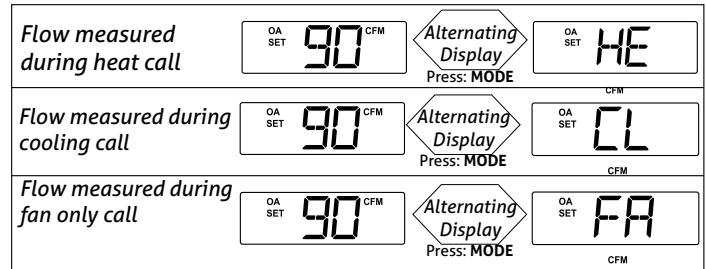

2.2 SETTING CODE REQUIRED CONSTANT AIR FLOW

Set the required continuous air flow in CFM based on relevant codes. For ASHRAE 62.2 see Appendix A. Factory default is 30 CFM. The AirCycler® g1 will calculate run times based on settings 2.1 and 2.2.

Press MODE to advance to the next setting



2.3 SETTING OPTIONAL MIXING TIME

If the user needs more central fan time for whole house mixing than the amount that is provided by ventilation time, the central fan can be configured to run an additional time period to complete the mixing period. Factory default is 0 or OFF. To use/change this setting press UP arrow. The fresh air damper will not be open during this extra time.

Press MODE to advance to next setting.



2.4 SETTING OPERATION HOURS

If the user does not want the ventilation system to run throughout the day you can set ON time and OFF time. Factory default is NO. If you are **not** setting an ON and OFF time, press MODE and continue to section 2.5.

If you want to set hours of operation press the UP arrow for yes [YS]. Press MODE to select yes. The AirCycler® g1 will prompt you to enter the hour you would like the ventilation to begin and the hour you want it to end followed by the current time.

Set the hour you want ventilation to START. Press MODE to advance to the next setting.

Set the hour you want the ventilation to STOP. Press MODE to advance to next setting.

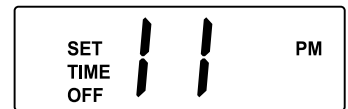

2.4.1 SETTING CURRENT TIME

Enter the current time. Press MODE to save all settings. Setup is complete.



2.5 CALCULATED FLOW SETUP IS COMPLETE

Set up is complete. The AirCycler® g1 will now return to normal operation.

3.0 CALCULATED TIME SETUP

3.1 SETTING NUMBER OF MINUTES PER HOUR OF SUPPLIED AIR FLOW REQUIRED

Enter the minutes per hour that you require fresh air to be brought into the home. Factory default is 20 minutes. Press MODE to advance to the next setting



3.2 SETTING OPTIONAL MIXING TIME

If the user needs more central fan time for whole house mixing than the amount that is provided by ventilation time, the central fan can be configured to run an additional time period to complete the mixing period. Factory default is 0 or OFF. The fresh air damper will not be open during this extra time. Press MODE to advance to the next setting.



3.3 SETTING OPERATION HOURS

If the user does not want the ventilation system to run throughout the day you can set ON time and OFF time. Factory default is NO. If you are **not** setting an ON and OFF time, press MODE and continue to section 3.4.



If you want to set hours of operation press the UP arrow for yes [YS]. Press MODE to select yes. The AirCycler® g1 will prompt you to enter the hour you would like the ventilation to begin and the hour you want it to end followed by the current time.

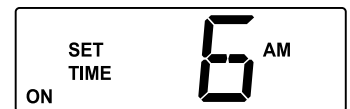

Set the hour you want ventilation to START.
Press MODE to advance to the next setting.

Set the hour you want the ventilation to STOP.
Press MODE to advance to the next setting.

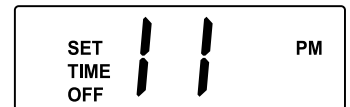

3.3.1 SETTING CURRENT TIME

Enter the current time.
Press MODE to save all settings. Setup is complete.



3.4 CALCULATED TIME SETUP IS COMPLETE

Setup is complete. The AirCycler® g1 will now return to normal operation.

4.0 NORMAL OPERATION DISPLAY

DISPLAY STATUS & SETTINGS

4.1 CURRENT STATUS

To get detailed status information, press the UP arrow during normal operation. The status screens are the same for both Calculated Flow and Calculated Time modes.

4.1.1 MINUTES LEFT

The first screen is the number of minutes left in the period (hour). Pressing the UP arrow again gets you to the next status screen



4.1.2 OUTSIDE AIR TIME ELAPSED

This display shows the number of minutes this period that the outside air damper has been open with the central fan running.

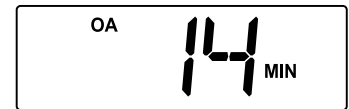

4.2 CURRENT SETTINGS

By pressing the DOWN arrow during normal operation, the user can scroll through the current settings entered by the installer.

For Calculated Flow mode the screens will show:

- Required CFM set
- Measured outside air CFM
- If operating time is enabled:
Operating Time ON
Operating Time OFF

For Calculated Time mode the screens will show:

- Outside air time in minutes
- If operating time is enabled:
Operating Time ON
Operating Time OFF

5.0 SET CURRENT TIME

By pressing the MODE key you will cycle through current time of day and will be able to change it if needed. See section 2.4 or 3.3 for details.

6.0 RESET TO DEFAULT VALUES

From normal operation hold the UP arrow for 15 seconds to be prompted to reset all settings to default. Press the UP arrow for yes [YS]. Press MODE to select yes.

7.0 POWERING OFF

Warning: It is not recommended to turn off the AirCycler® if the unit is used as a ventilation controller.

From normal operation hold the MODE button for 10 seconds. You will have the option to turn the unit off. Press the UP arrow for yes [YS]. Press MODE to select yes. The controller will shut off within a few seconds.

SOFTWARE VERSION

To determine the software version used in your controller press and hold the DOWN arrow for 15 seconds (from normal operation). The software revision number will be displayed on the screen.

APPENDIX A

ASHRAE 62.2 REFERENCE CHART

		Square Footage							
		1000	1500	2000	2500	3000	3500	4000	4500
No. of Bedrooms	1	25	30	35	40	45	50	55	60
	2	33	38	43	48	53	58	63	68
	3	40	45	50	55	60	65	70	75
	4	48	53	58	63	68	73	78	83
	5	55	60	65	70	75	80	85	90

CFM Required:

$$7.5 \text{ CFM} * (N+1) + A * 0.01$$

N = No. of Bedrooms A = Square Footage

APPENDIX B

TROUBLESHOOTING

Problem: No power to AirCycler® g1

Check common wire connection. "C" must be connected to "C" on the furnace.

Problem: Furnace fan is running constantly

Make sure the thermostat FAN switch is set to AUTO and not ON.

Problem: Central fan does not shut off when AirCycler® g1 is removed from base (when thermostat fan switch is on)

Check wiring - "G" wire from thermostat should be wired to "Gt" on AirCycler® g1. "Gf" on AirCycler® g1 should be connected to "G" on furnace.

Problem: Blank Display on the AirCycler® g1

Confirm:

1. The furnace has power
2. The thermostat is operational
3. The furnace will call for heat from the thermostat
4. The fan operates with a fan only signal from the thermostat
5. The furnace is providing 24 VAC to the AirCycler® g1
6. Verify wiring conforms to wiring diagram
7. Make sure cover is firmly seated on the base

Problem: AirCycler® g1 turns furnace fan on and off, but the motorized damper does not cycle.

Confirm:

1. The AirCycler® g1 is providing a 24 VAC signal to the motorized damper
2. The 24 VAC motorized damper is operational by powering directly with a 24 VAC signal
3. There is continuity in the wiring between the damper and the AirCycler® g1
4. Confirm damper power switch is in up or automatic position

Problem: A/C turns on during fan cycling calls

Confirm:

1. Wiring conforms to wiring diagram
2. The G wire is properly connected
3. The G wire needs to be interrupted by the AirCycler® g1
4. Do not run the G wire in parallel

Technical Support:
info@aircycler.com