

CEETSS-0039

Tools Required

13mm Socket

Ratchet

Torque Wrench



Step 1:

1. Locate (3) mounting positions on each side inner rocker panel.
2. Remove factory plugs or hex bolts from mounting positions.
3. Clean the sealant and dirt around mounting positions.

Step 2:

1. Attach proper bracket to inner rocker panel.
2. Secure the bracket using (2) M8 hex bolts, (2) M8 flat washers, (2) M8 lock washers.
3. Repeat to install all brackets.



Front Bracket



Center/Rear Bracket



Front



Passenger Right Side

Notes

Read this instruction carefully before starting installation.
 Proper tools will improve the quality of installation and reduce the time required.
 If missing parts or any damage found, please take a picture, and contact us.

Step 3:

1. Remove (6) M8 hex bolts and (6) M8 flat washers behind the step bar.
2. Slide mounting tracks to proper positions.
3. With assistance, lift and attach the step bar to brackets. Secure the step bar on brackets with (6) M8 hex bolts and (6) M8 flat washers.
4. Repeat to install the other side step bar.
Do not fully tighten.

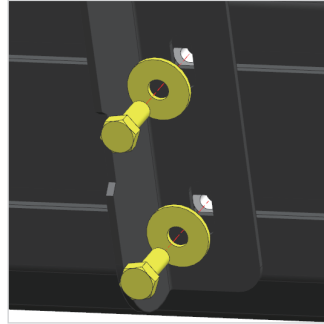

Step 4:

1. Tighten M8 hex bolts on vehicle with 15 ft. lbs. torque.
2. Adjust the step bar to level and tighten M8 hex bolts with 15 ft. lbs. torque.
3. After the step bar installed, periodic check to ensure all mounting hardware remains secure and tight.





Front

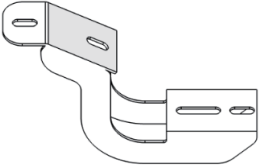
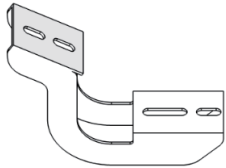
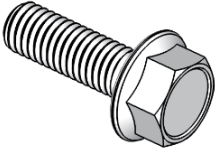
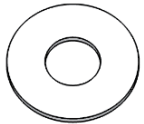

Passenger Right Side

Part List:

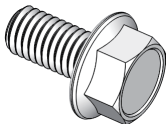
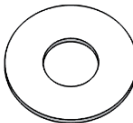
			
Front Bracket	×2	Rear Bracket	×4
			
M8 Hexagon Bolt	×12	M8 Flat Washer	×12
			
M8 Lock Washer	×12	M8 Hexagon Bolt (on step bar)	×12
			
M8 Flat Washer (on step bar)	×12		