



Tools Required:

- 13mm Socket
- Utility Knife
- Trim Tool
- Torque Wrench

Note:
Thoroughly clean the bottom of the body from the rear wheels to the front wheels.

Be careful not to damage the body paint finish. To prevent damage, place a blanket under the side step board during the installation.

These instructions show the left running board being installed; the same procedure applies to installing the right running board.

Part List:

- 2 Bracket Type A
- 2 Bracket Type B
- 2 Bracket Type C
- 44 M8×15 Flange Bolt



TYPE A



TYPE B



TYPE C

1. Remove the floor undercover.
For one-piece floor undercover.
(8) bolts, (1) small clip, (2) nuts, and (17) large clips.

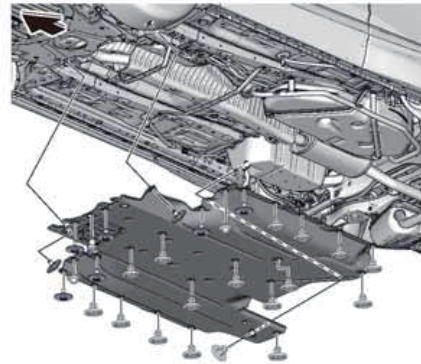

- For separate floor undercover.
Left: (3) bolts, (2) small clips, (1) nut, and (7) large clips.
Right: (2) bolts, (2) small clips, (1) nut, and (6) large clips.

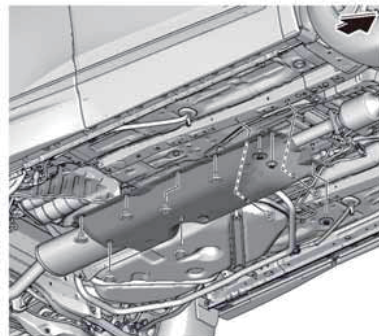
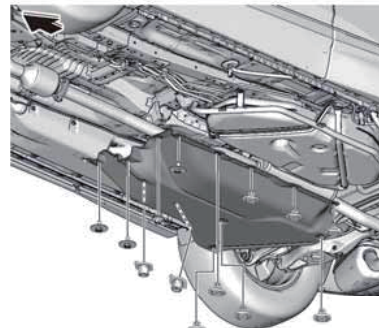

2. Using a utility knife, cut the insulator on the floor undercover and fold it into the inside of the insulator as shown if equipped insulator.
3. Using a utility knife, cut off the floor undercover as shown.
For one-piece floor undercover.

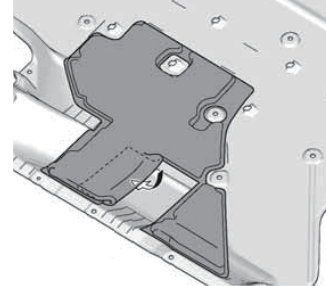

CUT ALONG THE SCRIBE LINES

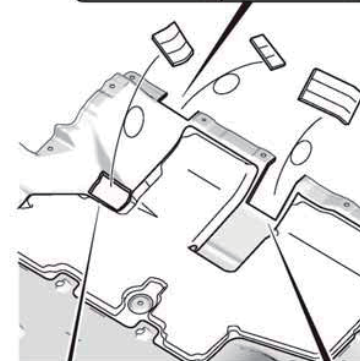
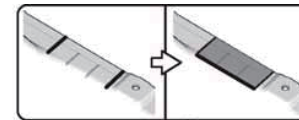

CUT ALONG THE SCRIBE LINES

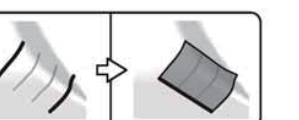

CUT ALONG THE SCRIBE LINES

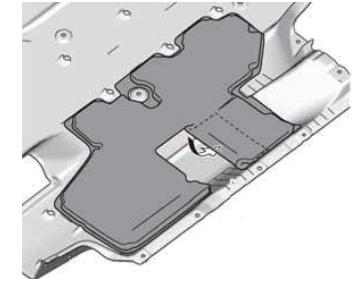

CUT ALONG THE SCRIBE LINES

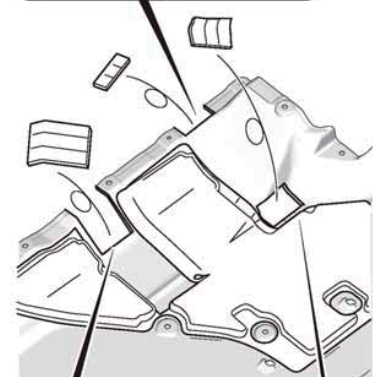

CUT ALONG THE SCRIBE LINES

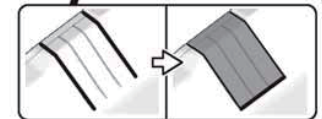

CUT ALONG THE SCRIBE LINES

INSTALLATION INSTRUCTIONS

For separate floor undercover.

LEFT
UNDERCOVER

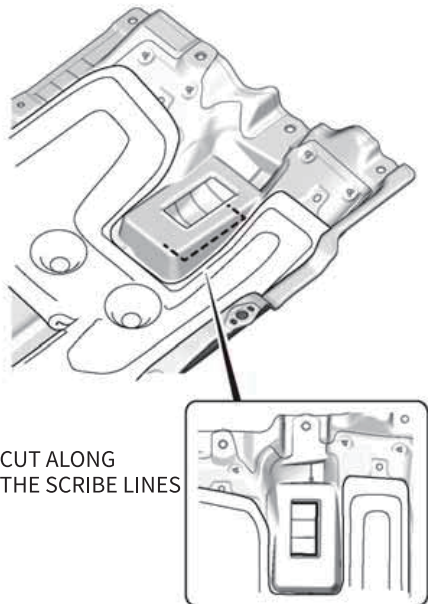
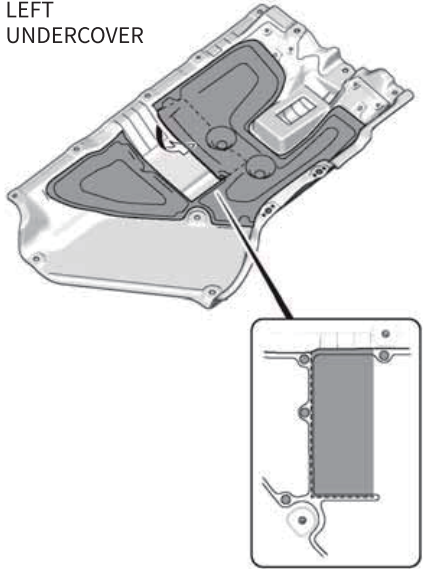

CUT ALONG
THE SCRIBE LINES

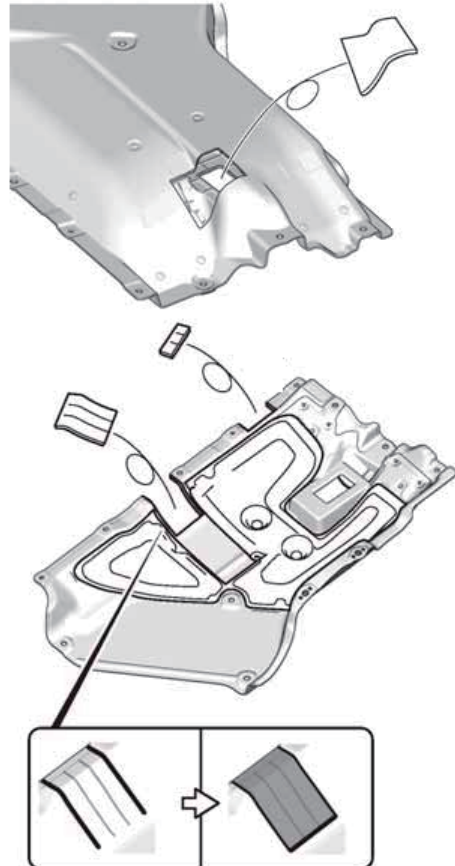
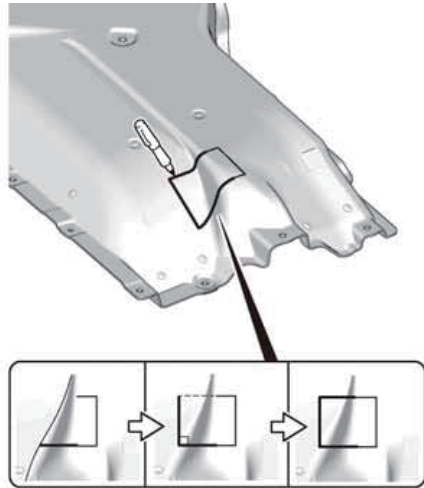

CUT ALONG THE SCRIBE LINES

-3-

INSTALLATION INSTRUCTIONS

RIGHT
UNDERCOVER

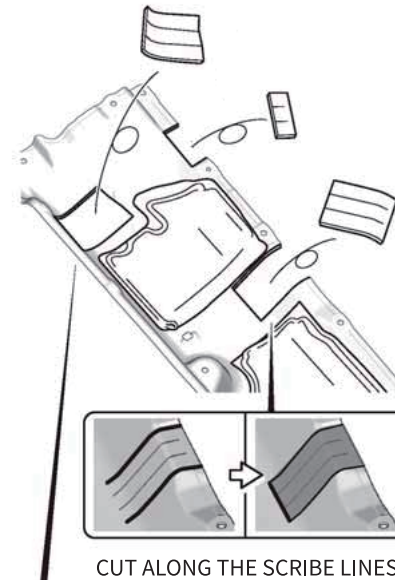
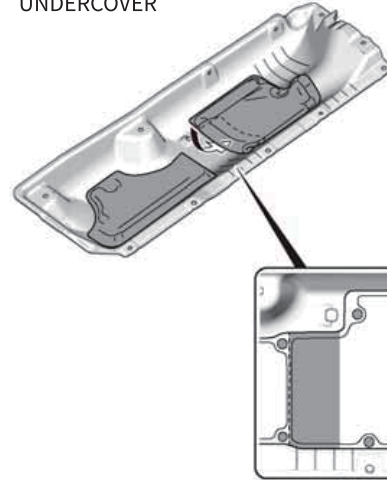

CUT ALONG THE SCRIBE LINES

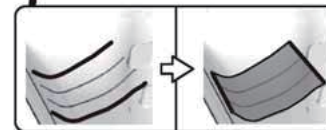

- Loosely secure bracket type B to the vehicle panel with (4) M8 flange bolts. Repeat on the other side. Tighten with 15 ft. lbs. torque.

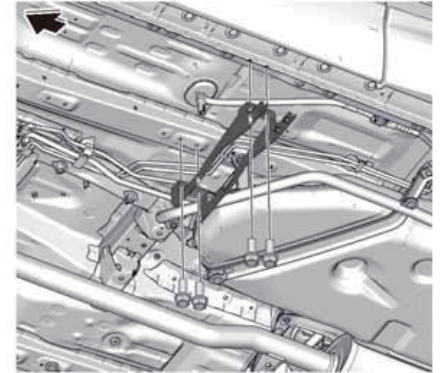

- Reinstall the floor the undercovers with original hardware.
- Loosely secure bracket type A to the vehicle panel with (4) M8 flange bolts.

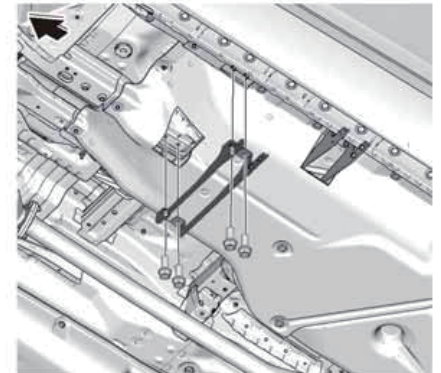

-4-

INSTALLATION INSTRUCTIONS

8. Loosely secure bracket type C to the vehicle panel with (2) M8 flange bolts.

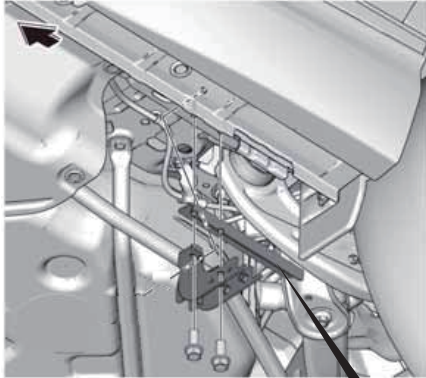

NOT INCLUDE

9. With the help of an assistant, loosely secure the left running board to bracket type A, type B, type C with (12) M8 flange bolts.

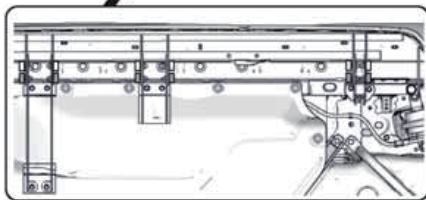
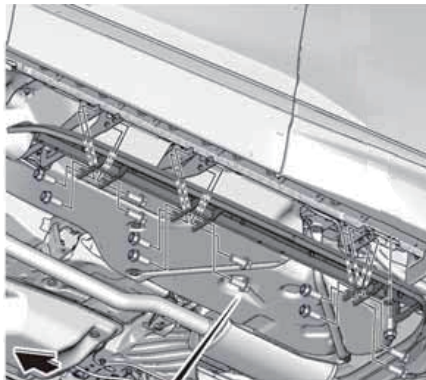

10. Tighten left running board to bracket type A, type B, type C with 15 ft. lbs. torque.

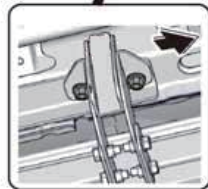
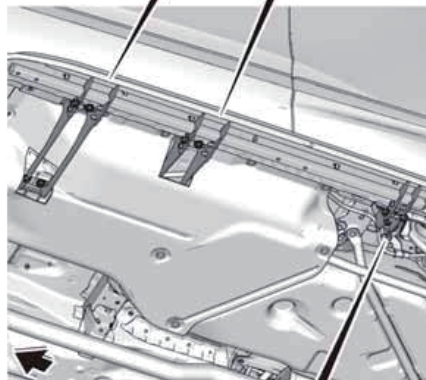

INSTALLATION INSTRUCTIONS

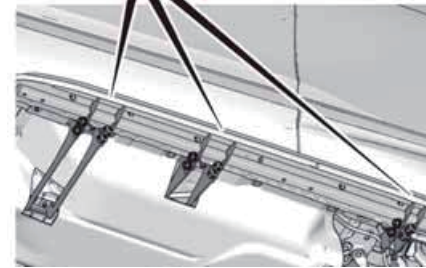

11. Repeat steps 6 through 10 on the right side of the vehicle.