

FOLDING INSTRUCTIONS

A4 ARCHIVE BOX - Lid attached

- 1** Lay your box out flat, as shown. Familiarise yourself with the numbered flaps.

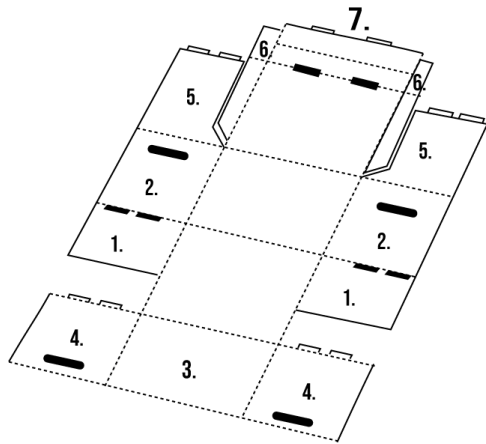

- 2** Fold the flaps marked (1) inward.

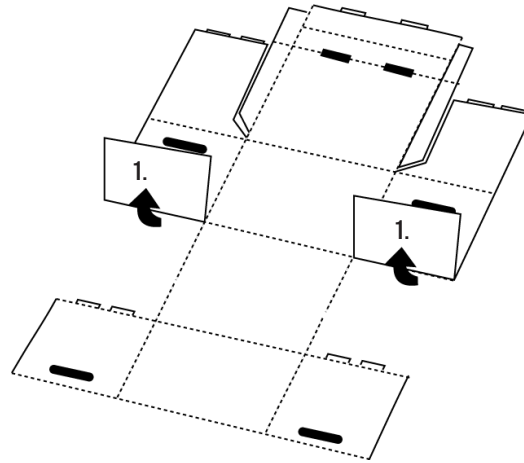

- 3** Fold the long side folds marked (2) inward so fold (1) meets in the centre.

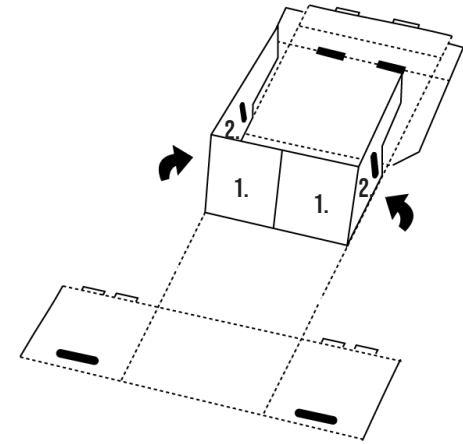

- 4** Fold the upper half of the box inward so that the box is standing. Fold the flaps marked (4) inward.

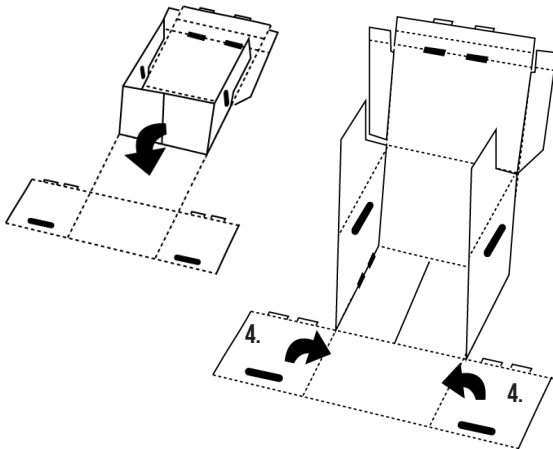

- 5** With flap (4) folded at a right angle, fold flap (3) inward. The tabs on flap (4) will align with the grooves located on flap (1).

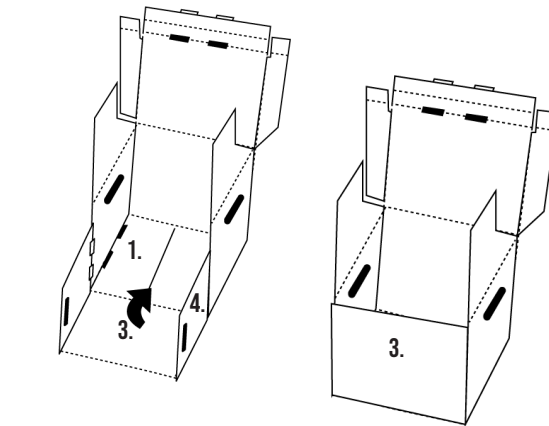

- 6** Fold the flaps marked (5) over the tops of flaps (4) until they click into the grooves at the bottom of the box.

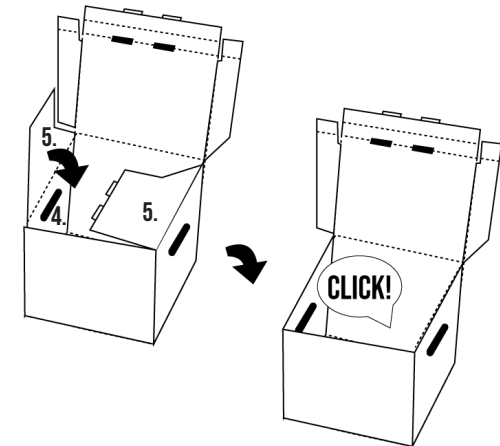

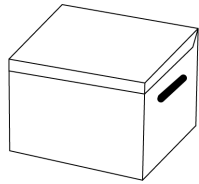

FOLDING INSTRUCTIONS

A4 ARCHIVE BOX - Lid attached

7 Take the flap marked (6) and fold the top of it downward to a right angle. Then take the whole flap and fold inward.

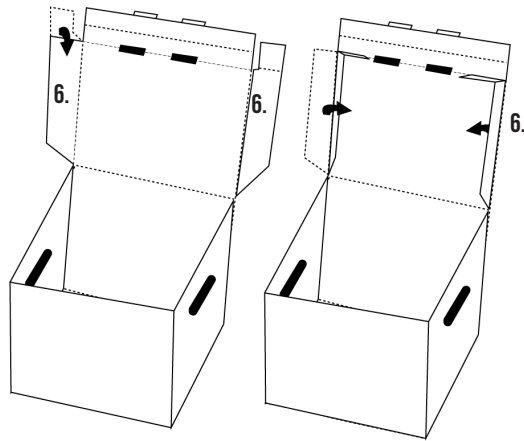

8 Take flap (7) and fold it down over the top flap (6). Make sure the tabs on flap 6 fit into the grooves on the lid of the box.

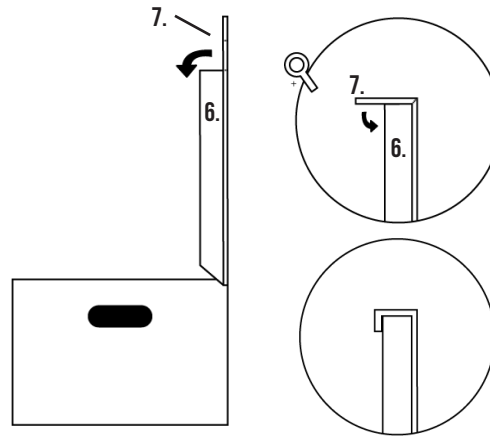

9 Shut the lid and give yourself a round applause. Your box is complete!

