



VACUUM PUMP

Operating Manual



For questions, comments, or concerns

Please call Hardware Factory Store Inc.

Call: 626.332.7744

Mon-Fri : 10:00AM - 6PM

1029 N Todd Ave, Azusa CA 91702

WARNING: To reduce the risk of injury, do not attempt to use or maintain this unit until you read and understand these instructions. Do not permit untrained persons to use or maintain

We appreciate you for choosing HFS' VACUUM PUMP. [Visit us online](#) to see our full line of products available for your Business.

Content

Content	1
I .Pump Components	1
II .Operating Manual	1
1.Before operating.....	1
2.To shut off pump after use	2
III.Maintenance	2
1.Vacuum pump oil.....	2
2.Oil Change Procedure	2
IV.Troubleshooting Guide	3
1.Failure to Start.....	3
2.Oil leakage	3
3.Failure to Attain A Good Vacuum.....	3
VI.Technical Parameter	5
VII.Dual Voltage & Dual Frequency Series	5

I .Pump Components



II .Operating Manual

1.Before operating

All motors are designed for operating voltages plus or minus 10% of the normal rating. Single voltage motors are supplied fully connected and ready to operate.

(a)Check the voltage and frequency at the outlet and ensure it matches the specifications on the pump motor metal plate. Ensure that the ON-OFF switch is in the OFF position before connecting the pump to a power source. Remove and discard the exhaust plug from the exhaust fitting.

(b)Fill the oil reservoir with oil before activate the pump. Remove the Oil Fill cap and add oil until oil show at the bottom of the sight glass. Refer to technical data in manual for the correct oil capacity of pump.

(c)Place back the Oil Fill cap and remove the cap from the inlet fitting. Turn the motor switch to ON position. Place back the cap on the inlet fitting when the pump runs smoothly. This may takes 2 to 30 seconds depends on the ambient temperature. After the pump operates for approximately one minute, check the sight glass for proper oil level, which should be aligned with the sight glass Oil Level line. Refill oil if necessary.

Note: The oil level should be aligned with the indicating line on the sight glass when the pump is running. Insufficient oil filled will result in poor vacuum performance.

Excessive of oil can result in overflowing of oil from the exhaust fitting. **To reduce the risk of injury, when applying to the R32 and HFO-1234yf, please be sure to operate the pump at cool and ventilated place.**

2.To shut off pump after use

To prolong pump lifespan and smooth start-up, these procedures to shut off pump should be followed.

- (a)Turn off the manifold valve between the pump and the system.
- (b)Remove the hose from the pump inlet.
- (c)Cover the inlet port openings to prevent any contamination or foreign particles from entering the port.

III.Maintenance

1.Vacuum pump oil

The condition and type of oil used in any high performance vacuum pump are extremely important in determining the ultimate attainable vacuum. It is recommended to use the High Performance Vacuum Pump Oil, which is specifically blended to maintain maximum viscosity at normal running temperatures and to improve cold weather start up.

2.Oil Change Procedure

- (a)Ensure the pump is warmed up.
- (b)Remove the Oil Drain cap. Drain off contaminated oil into a container and dispose it properly. Oil can be removed from the pump by opening the inlet and partially blocking the exhaust with a cloth while the pump is running. Do not operate the pump for more than 20 seconds using this method.
- (c)When the drainage of oil completed, tilt the pump forward to remove the residual oil.
- (d)Place back the Oil Drain cap. Remove the Oil Fill cap and fill the oil reservoir with new vacuum pump oil until the oil level is seen at the bottom of the sight glass.
- (e)Ensure that the inlet ports are covered before turn on the pump. Allow it to run for one minute to check the oil level. If the oil level is below the sight glass Oil Level line, fill oil slowly(with the pump running) until the oil reaches the Oil Level line. Place back the Oil Fill cap, ensure the inlet is covered and the oil drain cap is closed tightly.
- (f)i) If the oil is badly contaminated with sludge that forms during operation, you may need to remove the oil reservoir cover and wipe it.
- ii)The alternative method to deal with heavily contaminated oil is to force the oil from

the pump reservoir. Leave the pump to run until it is warmed up. While the pump is still running, remove the oil drain cap and restrict the exhaust slightly. This will back-pressure the oil reservoir and purge the oil with contaminants. Turn off the pump when oil stop flowing.

iii) Repeat this procedure as required until the contaminants is removed completely.

iv) Replace the Oil Drain cap and refill the oil reservoir to the proper oil level with clean vacuum pump oil.

IV. Troubleshooting Guide

Following guide will help you to recover the functionality should there be any malfunction occurs:

1. Failure to Start

Check the operating voltage. The pumps are designed to start at $\pm 10\%$ operating voltage (loaded) at 5 °C. However, if exceeded the maximum voltage, switch malfunction may occur.

2. Oil leakage

(a) Ensure the oil is not a spillage from vacuum pump, etc.

(b) If leakage exists, the housing gasket or the shaft seal may need to be replaced. If leakage exists in the area of the oil drain plug, you may need to reseal the plug using a commercial pipe thread sealer.

3. Failure to Attain A Good Vacuum

(a) Ensure the vacuum gauge and all connections are in good condition and leakfree. You can confirm leakage by monitoring the vacuum with a thermistor gauge while applying vacuum pump oil at connections or suspected leak points. The vacuum will improve briefly while the oil is sealing the leak.

(b) Ensure the pump oil is clean. A badly contaminated pump may require several oil flushes.

(c) Ensure the oil is at the proper level. For optimum pump operation, the oil must be even with the Oil Level line on the sight glass when the pump is running. Do not overfill as operating temperatures will cause the oil to expand, which will appear at a higher level than when the pump is not running. To check the oil level, start the pump with the inlet covered. Check the oil level in the sight glass. Add oil if necessary.

V. Technical Drwaing

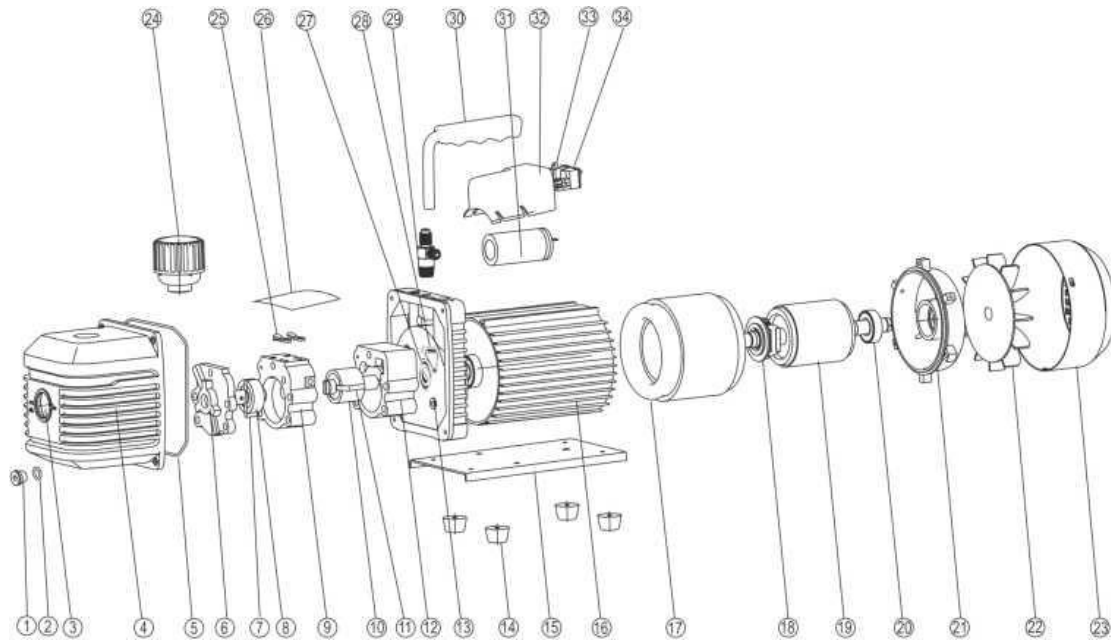

1.OIL DRAIN VALVE	13.TRESTLE	23.FAN COVER
2.O RING	14.RUBBER FOOT	24.EXHAUST
3.SIGHT GLASS	15.BASE	25.VALVE PLATE
4.HOUSING	16.MOTOR HULL	26.ANTI-FOG
5.O RING	17.MOTOR STATOR	27.O RING
6.PUMP BACK	18.CENTRIFIGAL	28.O RING
7.BACK ROTARY	19.MOTOR ROTOR	29.INLET FITTING
8.PUMP BACK	20.BEARING	30.HANDLE
9.PUMP BACK	21.MOTOR COVER	31.CAPACITOR
10.PUMP FRONT	22.FAN	32.CAPACITOR BOX
11.FRONT ROTORY		33.SOCKET
12.PUMP FRONT		34.POWER SWITCH

VI. Technical Parameter

Models	VP1200	VP160	VP130
Frequency	60Hz	60Hz	60Hz
Flow Rate	12CFM 340L/min	6.0CFM 170L/min	3.0CFM 85L/min
Ultimate Vacuum	2Pa	2 Pa	2Pa
	150 microns	150 microns	150 microns
Stage	1	1	1
Power	1HP	1/2HP	1/4HP
Inlet Port	1/4"&3/8"SAE	1/4"&3/8"SAE	1/4"SAE
Oil Capacity	600ml	300ml	230ml
Dimensions(mm)	340x132x245	320x125x232	240x93x200
Weight	12.0kg	8.0kg	4.3kg

Models	VP2200	VP260	VP230
Frequency	60Hz	60Hz	60Hz
Flow Rate	12CFM 340L/min	6.0CFM 170L/min	3.0CFM 85L/min
Ultimate Vacuum	2×10^{-1} Pa	2×10^{-1} Pa	2×10^{-1} pa
	15 microns	15 microns	15 microns
Stage	2	2	2
Power	1HP	1/2HP	1/3HP
Inlet Port	1/4"&3/8"SAE	1/4"&3/8"SAE	1/4"&3/8"SAE
Oil Capacity	630ml	330ml	300ml
Dimensions(mm)	390x145x252	320x125x230	280x115x230
Weight	16kg	9.0kg	7.8kg

VII. Dual Voltage & Dual Frequency Series

Use below outlook drawing for better understanding of Dual Voltage & Dual.

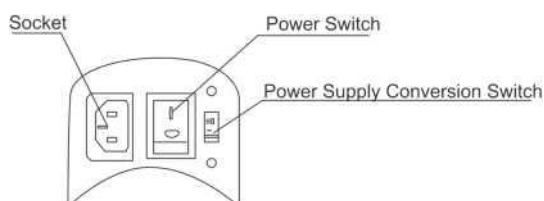

Note:

1.This product operates in ambient temperature:5°C~40°C;

2.Power Supply of the products are 110-127V 50/60Hz, 220-240V 50/60Hz;

Check power supply parameter before using the vacuum pump and ensure the Power Supply Conversion Switch is set at the right place: 110V or 220V.

3.This product is equipped with Thermal Protection function:

If the ambient temperature is too hot or the voltage is too high, the product may stop functioning. It is recommended not to switch off the power supply immediately.

If the product re-start up automatically after 3 minutes, it is recommended to cool the product by lowering the ambient temperature or power supply voltage to prolong the lifespan of the vacuum pump.