

BRE-100, BRE-200

# Rotary Evaporator

## Operating Instruction



## Contents

1. Working principle and scope of application.....	2
2. Precautions.....	2
3. Structure and composition.....	5
3.1.....	5
3.2.....	7
3.3.....	8
4. Installation.....	9
4.1 Stripping.....	9
4.2 Installation diagram of pole.....	9
4.3 Installation diagram of 3 way flask, rotary joint, evaporating flask.....	10
4.4 Installation diagram of main vertical condense and receiving flask.....	11
4.5 Other parts installation.....	12
5. Specification.....	12
6. Operating instructions.....	13
6.1 Preparation before operation.....	13
6.2 Instructions for use.....	13
7. Troubleshooting.....	16
8. Maintenance.....	17
Packing List.....	19

## 1. Working principle and scope of application

Laboratory equipment Rotary evaporator is mainly used for continuous distillation of a large number of volatile solvents under reduced pressure conditions. In particular, the reaction product can be isolated and purified by concentrating the extract and distilling the receiving liquid upon chromatographic separation. The basic principle of rotary evaporator is vacuum distillation, that is, under reduced pressure, the distillation flask is continuously rotated when the solvent is distilled.

## 2. Precautions

### Safety warning !



#### **Dangerous (may result in serious loss of property or casualties)**

- 1 The instrument must be grounded and away from sources of electromagnetic interference (must not be zero line or middle line for the ground);
1. Please use this product in the laboratory environment, the use and operation of this product must undergo a professional study or training, laboratory safety knowledge, and have some basic knowledge of physics, chemistry, biology, medical and other professional knowledge and related Laboratory skills
2. Please comply with safety norms, personal safety and accident prevention and other related norms, especially in the vacuum!
3. Do not allow lengthen or shorten instrument power cable at will.
4. Do not refit this instrument, do not use for other purposes than the provisions of this product, if refit this instrument or or used for other purposes may lead to electric shock or cause equipment failure;
5. This product is non-explosion-proof specifications, do not put in a place of environmental risk, if use in dangerous place will lead to fire and other accidents; Do not heat solvents under atmospheric pressure;
6. If flammable samples or organic solvents, Please take care not to spill the solution
7. The function or performance of the product, the host part need to rotate use in the high temperature water bath, at the same time, there are glass components in this product, The glass will split if the use is improper and cause accidental injury or accident
8. Do not disassemble the instrument. There is voltage or high temperature inside the

instrument. If decomposition instrument will cause personal injury.



**! Warning (may cause property damage or personal injury)**

1. Before use, please confirm the voltage and frequency of the power supply match the requirements of the instrument;
2. The instrument should use a separate power outlet, and confirm the plug, socket grounding good;
3. Do not allow to unplug the power plug under the operation of the instrument does not turn off the power switch;
4. Before use, please carefully check the equipment, accessories, especially glass components are damaged, do not use damaged parts;
5. The instrument is only suitable for the medium that does not react to the energy generated in the process to produce dangerous medium; at the same time, the material to be processed could not react with the energy generated by other ways, such as light to generate danger;
6. In the operation of this product need to wear safety glasses and appropriate protection devices, prohibit the use of non-heat-resistant, fragile and other safety-affecting containers and aids;
7. Shall not be repaired without authorization, commissioned by the company must be repaired by professionals;
8. Please use the correct method and supplies appliances for cleaning and maintenance of this product.



**! Note (may affect the service life of the instrument cause it could not work normally)**

1. The product should be placed in a hard and firm plane, to keep it level;
2. Handling equipment, please hand support instrument base and hold the fuselage together with handling;
3. Water bath should be energized after inject water, not allowed to dry without water;
4. Glass should be hand gently, washed and dried;
5. The use of grinding mouth instrument before installation should be evenly coated with a small amount of vacuum grease;
6. Expensive solution should be done first simulation test, confirm the instrument is applicable and then transferred to the normal application;

7. The product should be retained around the gap, to ensure that there is enough space above the instrument, the glass components may exceed the height of the instrument;
8. The product must be used under certain conditions of use;
9. To ensure that the instrument does not move due to vibration when opened;
10. To keep the use of the environment clean and dry, away from the heat source, a strong magnetic field, flammable or other similar magnetic products;
11. This product could not invade the liquid, must not move while using, must unplug the power cord when moving or cleaning;
12. After the work, turn off the switch, unplug the power plug;
13. Long-term non-use, please turn off the power switch, and unplug the power plug from the outlet.

### 3. Structure and composition

#### 3.1 Rotary Evaporator Outside view (Only for reference)

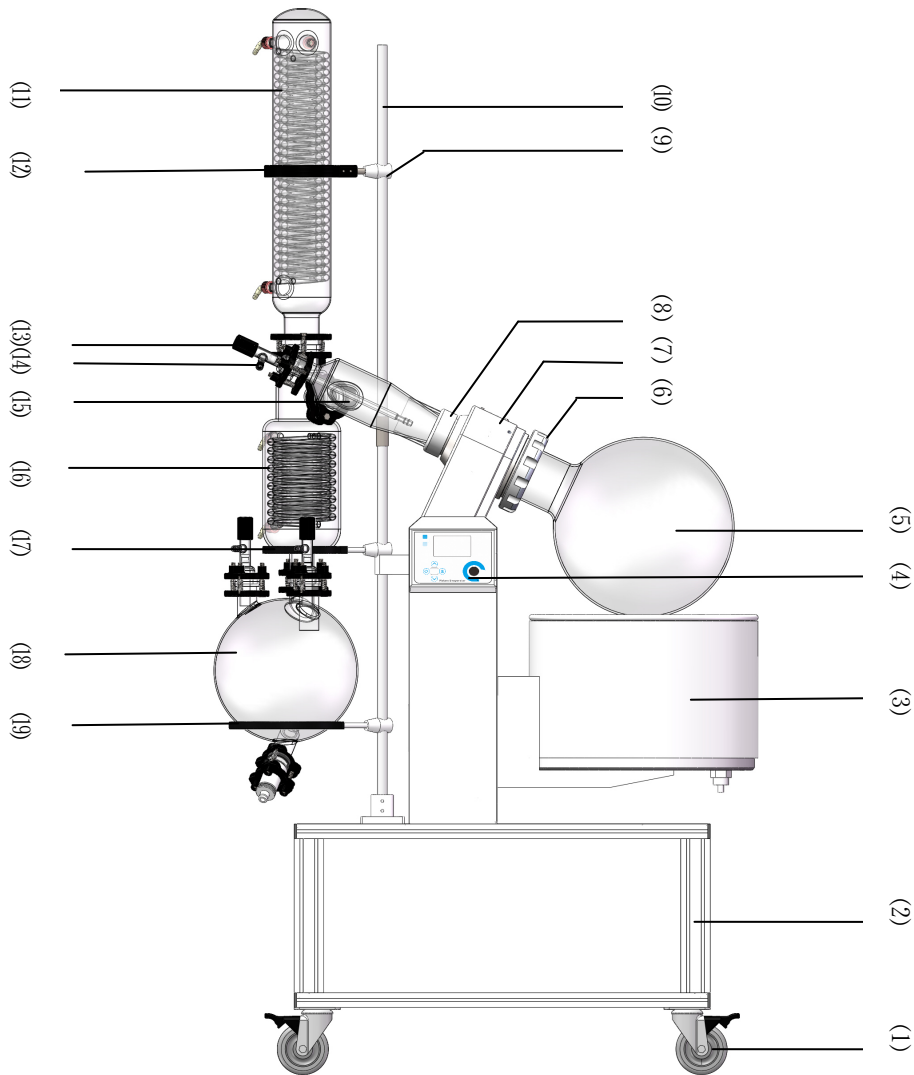

**Outside view (Figure 1)**

- |  |   |  |
|--|---|--|
| (4) Castor                                   | (2) Base support                        | (3) Heating bath                       |
| (4) Operating panel                          | (5) Evaporating flask                   | (6) Cap screw for evaporating flask    |
| (7) Machine head                             | (8) Cap screw for 3 way flask           | (9) Main vertical condense clamp mount |
| (10) Pole                                    | (11) Main vertical condense (Figure 2)  | (12) Main vertical condense clamp      |
| (13) Replenishment knob                      | (14) Continuous feed port               | (15) 3 way flask (Figure 3)            |
| (16) Secondary vertical condenser (Figure 4) | (17) Secondary vertical condense holder |  |
| (18) Receiving flask (Figure 5)              | (19) Receiving flask holder             |  |

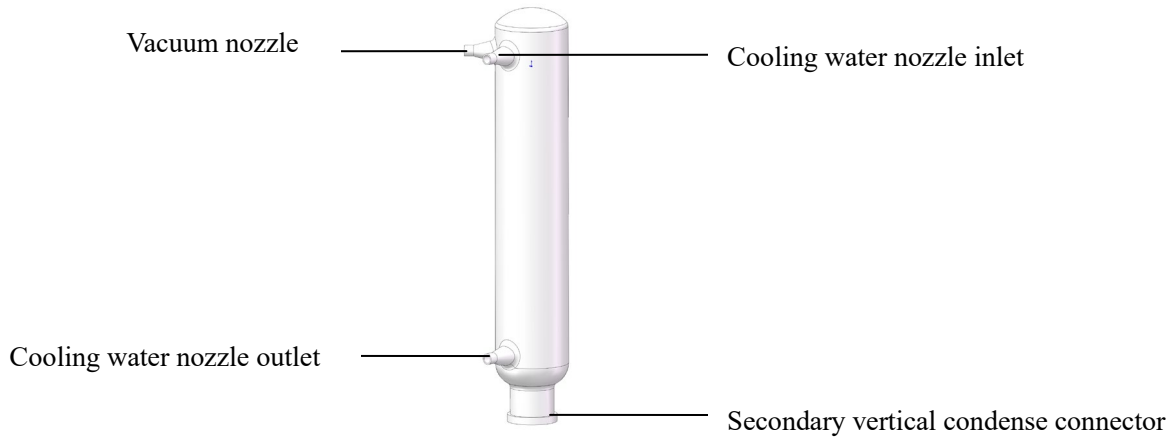

Figure 2

**3 way flask structure diagram:**

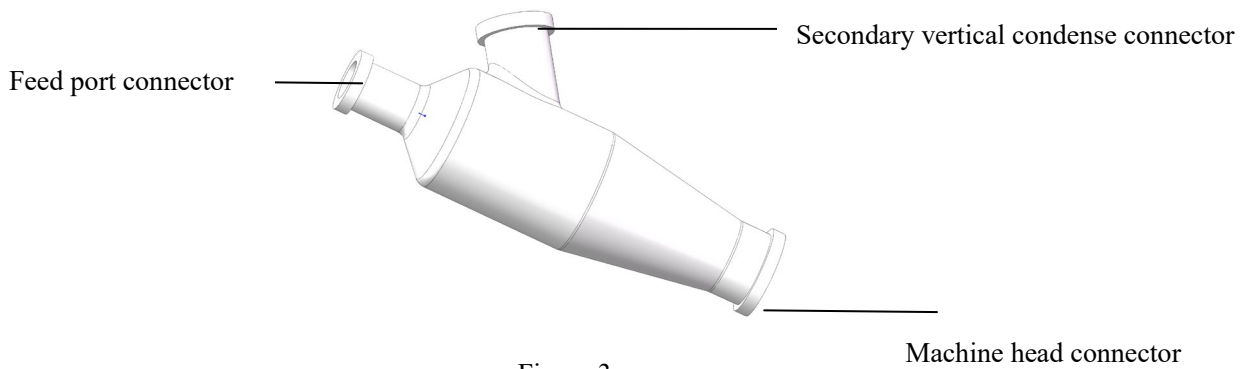

Figure 3

**Secondary vertical condenser structure diagram:**

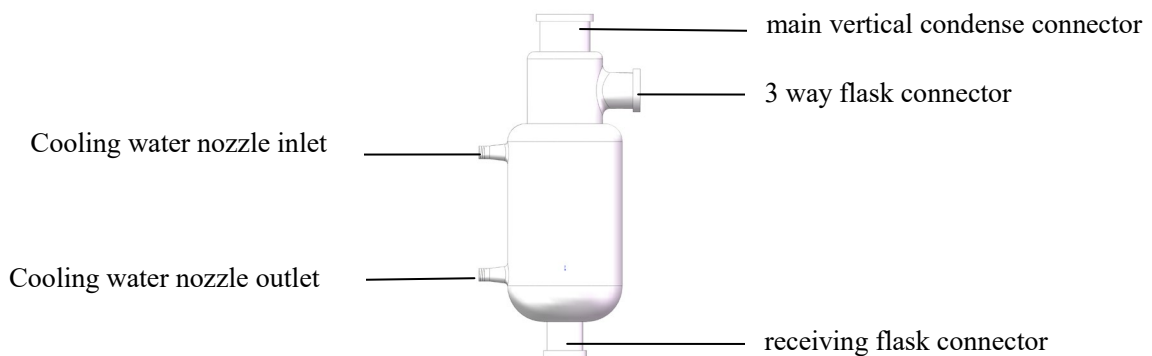

Figure 4

**Receiving flask structure diagram:**

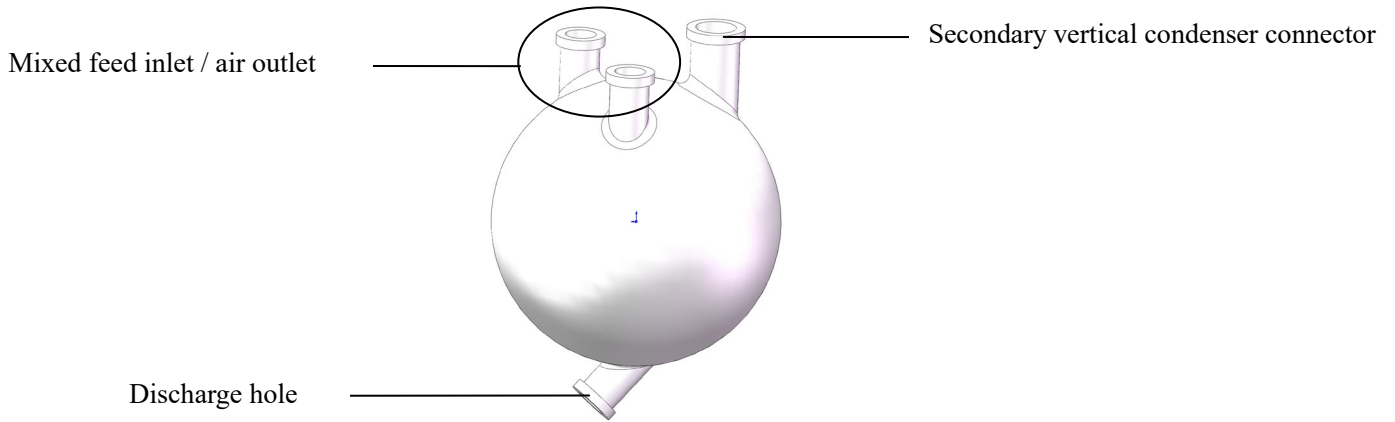
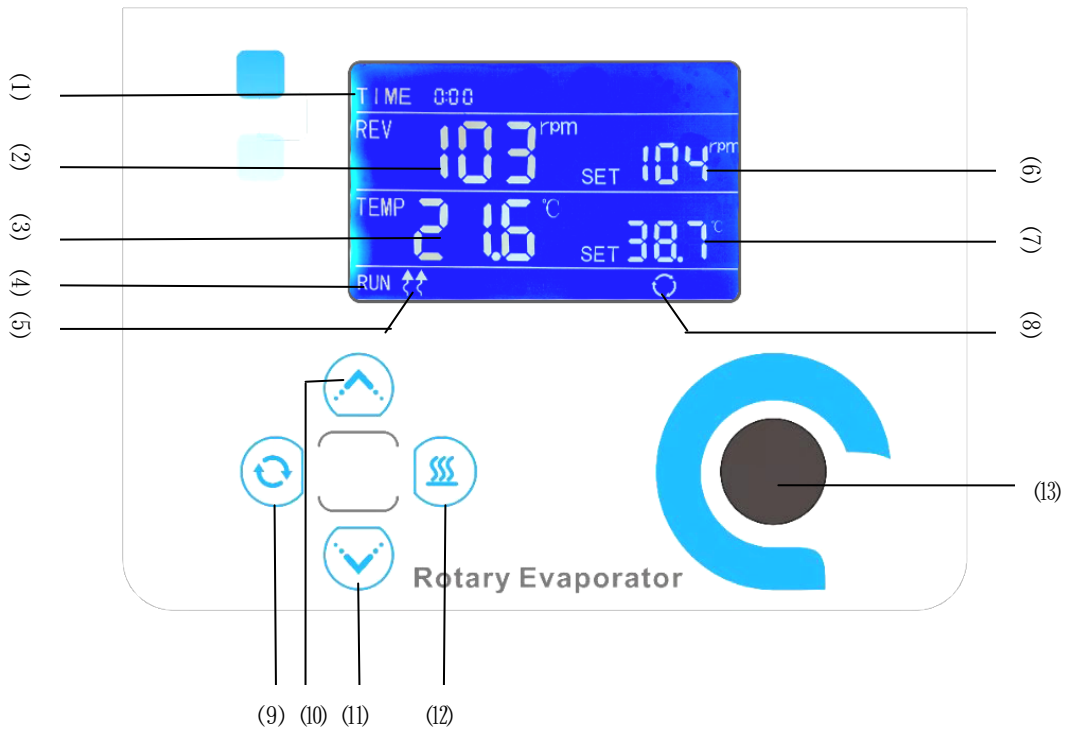

Figure 5

**3.2 Rotary Evaporator Operating Instructions for operating panel(Figure 6)**





Operating panel (Figure 6)

- (1) TIME: Time display window; When the controller is in a timed state, "TIME" will display the running time (countdown)



- (2) REV: Measured speed window;
- (3) TEMP: Measured temperature window;
- (4) RUN: Heating or rotating indicator, it will display when in heating or rotating status;
- (5) Heating indicator: It will display when there is a heating output;
- (6) REV SET: Display setting speed, or display parameter value;
- (7) TEMP SET: Display setting temperature, or display parameter value;
- (8) Rotating indicator: Lights when rotating

(9) Key: turn on or turn off rotation function;

(10) Key: adjust the height of the host, press and hold this key can raise the water bath automatically;

(11) Key: adjust the host height, press and hold this key can lower the height of water bath automatically

(12) Key: turn on or turn off heating function;

(13) Knob key: Rotate left and right to set the time, temperature, and speed values.

### 3.3 Operation instructions

Turn on the instrument: Plug in the power and press the key on the left side of body to the "1" position.

When the rotary evaporator is on:

#### 1)Time setting



Press pressing the knob for once, when "TIME" value flash, turn the knob left and right to adjust the desired time value, and press the knob key for once to confirm the time setting value;

#### 2)Speed setting



Press pressing the knob for once, when "REV SET" value flash, turn the knob left and right to adjust the desired speed value, and press the knob key for once to confirm the speed setting value;

#### 3) Temperature setting

Press pressing the knob for once, when "TEMP SET" value flash, turn the knob left and right to adjust the temperature speed value, and press the knob key for once to confirm the temperature setting value;

4)When the speed ,time and temperature setting is completed, press  key or  key to start heating or rotating.

Note: The setting time is the running time, in minutes, it starts timing when you press

""key, it will stop rotation after time is over, or press "" key to stop the rotation in working status.

## 4. Installation

### 4.1 Stripping

(1) Open the package, please check the parts according to the packing list. If there is any missing parts, please contact us.

(2) Carefully clean the glass to maintain cleanliness before assembly.

(3) Prepare all the tools you need for installation.

**Note:** The glassware set is fragile, please carefully unpack it.

### 4.2 Installation diagram of pole

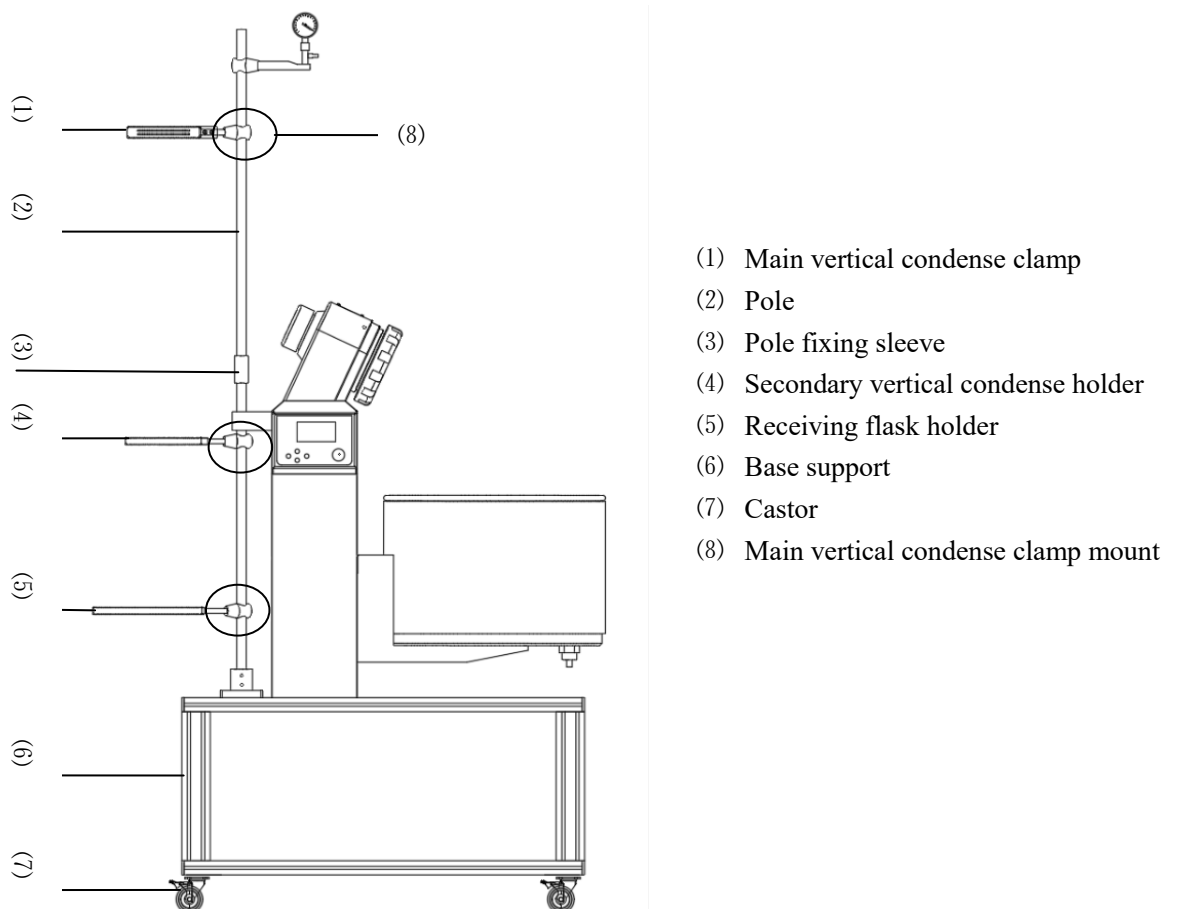

Figure 7

Installation process:

1. The pole (Fig. (2)) is inserted into the pole fixing sleeve (Fig. (3)), Adjust the position and tighten the two screws on the pole fixing sleeve;
- 2.If need t adjust the height of the main vertical condense clamp (Fig. (1)) and secondary vertical condense holder, receiving flask holder (Fig. (5)), just loosen the two screws on the mount, move up and down to the desired height and tighten the screws

#### 4.3 Installation diagram of 3 way flask, rotary joint, evaporating flask

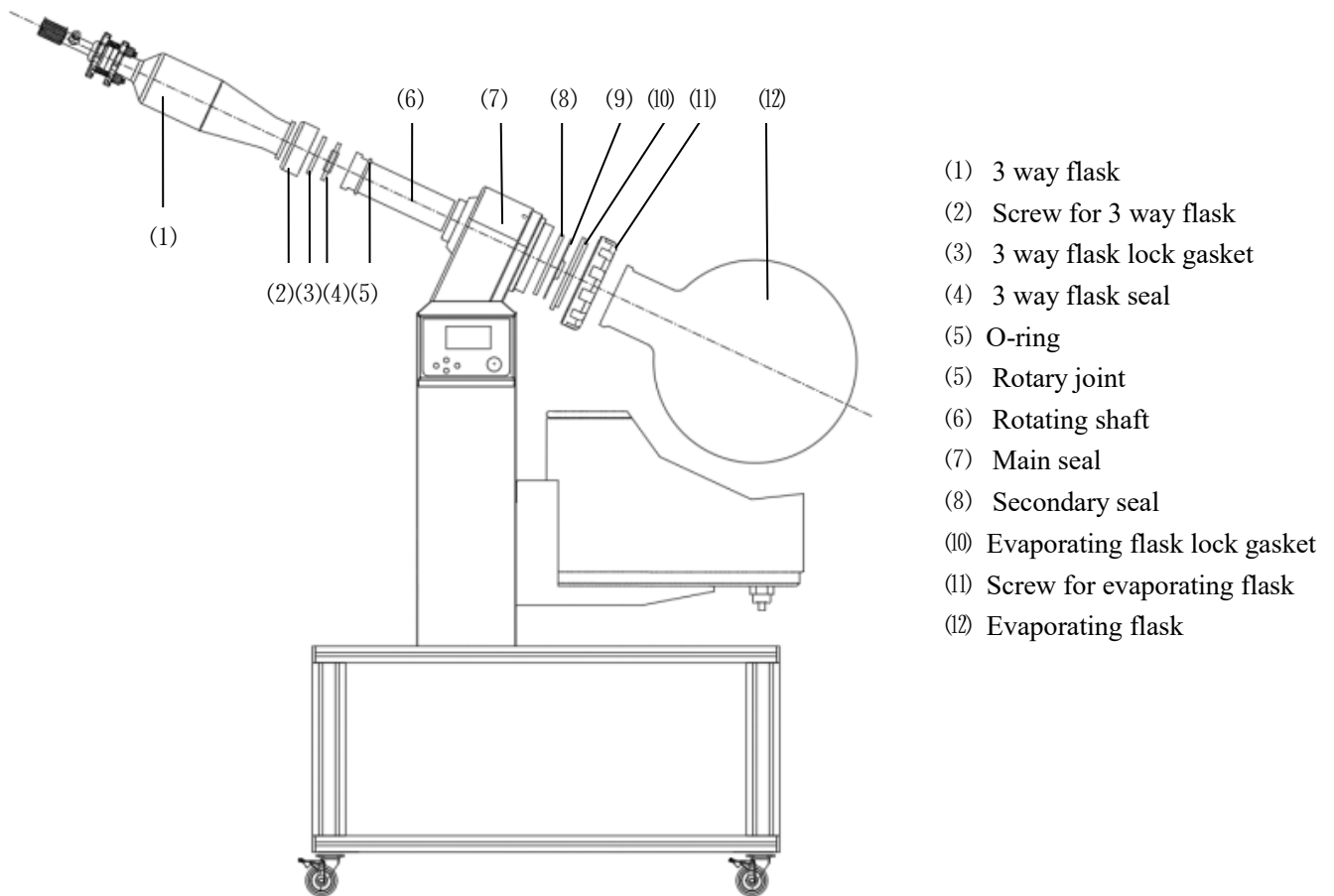

Figure 7

Installation process:

1. Put the O-ring (Fig. (5)) on the glass rotating shaft (Fig. (6)), Then, Then insert the glass rotating shaft into the rotating mechanism from the left side, And requires that the O-ring on the glass rotating shaft close to the rotating mechanism housing
2. Put the screw for 3 way flask (Fig. (2)) on the lower port of the 3 way flask (Fig. (1)), Then put the 3 way flask lock gasket(Fig. (3)) on the lower neck of the 3 way flask, insert the 3 way flask seal(Fig.(4)) into the diameter of the 3 way flask, finally insert the 3 way flask into the upper end of the glass rotating

shaft, adjust the position of the 3 way flask, tighten the screw for 3 way bottle lock properly .

3. Install the main and secondary seals on the right side of the glass rotating shaft (Fig. (8)(9)), place the screw for evaporating flask(Fig. (11)) on the base of the evaporating flask neck, evaporating flask lock gasket(Fig. (10)) placed on the neck of the rotating bottle, tighten the screw for evaporating flask properly.

Positioning the evaporating flask: Insert the inner hexagon wrench into the hole of the rotating base (inclined left), adjust the position of the rotating shaft, align the hole in the shaft with the hole in the base, use the inner hexagon wrench to keep the position of the rotating shaft unchanged, install the evaporating flask with screw and gasket on the right end of the glass rotating shaft, tighten the screw for evaporating flask. Start the rotating shaft and observe its operation, and the rotating shaft is required to run smoothly.

**Note: During the installation process, the glassware set should be handled gently, and the position of the flask mouth and the flask mouth should be appropriate to avoid damage the glass device!**

#### 4.4 Installation diagram of main vertical condense and receiving flask

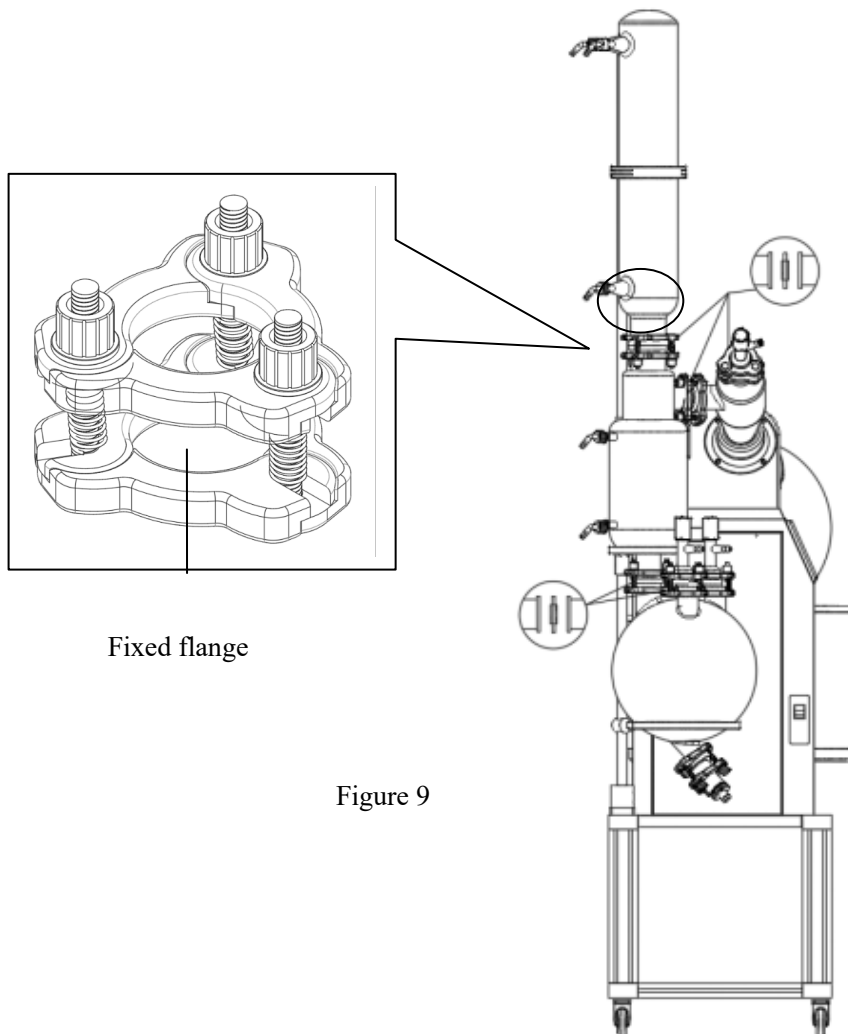

Figure 9

Installation process:

1. Fix secondary vertical condense holder on the pole and place the secondary vertical condense on the holder, adjust the required height, keep the secondary vertical condenser side interface and the 3 way flask interface at the same level, tighten the screws of secondary vertical condense holder and the clamp mount. Then install the fixing flange on the root of the secondary vertical condenser interface, install the flange retaining ring on the neck of the secondary vertical condenser, and tighten the screws on the fixing flange.
2. The installation method of main vertical condense is the same as secondary vertical condense, fix main vertical condense holder on the pole and place the main vertical condense on the holder, put the fixing flange at the lower end of the main vertical condenser, while placing the flange retaining ring, align the lower end of the main vertical condenser with the upper end of the secondary vertical condense, and tighten the screws on the fixing flange.
3. Loosen the two screws on the receiving flask holder, move up and down to the desired height and tighten the screws, fixing the receiving flask holder and the mount; place the receiving flask on the holder, install the fixing flange on the root of the receiving flask interface, and place the flange retaining ring at the same time, use the same method to connect and secure the upper end of the receiving flask to the lower end of the secondary vertical condense

**Note: During the installation process, the glassware set should be handled gently, and the position of the flask mouth and the flask mouth should be appropriate to avoid damage the glass device!**

#### 4.5 Other parts installation

- (1) Vent valve installation: Install the bleed valve directly in the diameter of the receiving flask;
- (2) Installation of vacuum gauge: Install the vacuum gauge holder and vacuum gauge on the vacuum gauge clamp, tighten the screws and adjust the bracket to the appropriate height.

## 5. Specification

Table 1

Model		
Index	BRE-100	BRE-200
Rotation speed	20~130 rpm	
Bath temp. control range	RT+5~99 °C	
Speed setting	Knob setting +LCD controller	
Lifting method	Manual electric	
Water bath heating method for water bath	Built-in heating	
Main motor	DC brushless	
Cooling area (m <sup>2</sup> )	0.39+0.253	0.948+0.458
Vacuum seal	PTFE+Teflon coating	

Material of water bath	Stainless steel corrosion resistant coating	
Heating Power	3000W	4300W
Ambient Temperature	5~35°C	
Bath Dimensions (inner) φ×H (mm)	Ø345*225	Ø445*250
Power Consumption	220V 50/60HZ	

Note: This product is available with a recirculating chiller and a corrosion-resistant diaphragm pump!

## 6. Operating instructions

### 6.1 Preparation before operation

Ensure that the product use environment meet the following conditions of use:

- 1) Use it in the room;
- 2) Ambient temperature: 5~35°C;
- 3) Power supply: AC 220V 50/60HZ;
- 4) Atmospheric pressure: (86~106)KPa;
- 5) Altitude no higher than 4000 meters;
- 6) Use of the environment: low humidity, no hanging drops, no condensation, good ventilation, no direct sunlight;
- 7) No intense shock source and strong electromagnetic field around;
- 8) It should be placed on a steady, horizontal and solid bench or ground without direct sunlight. No heavy dust or corrosive gas in the room;
- 9) There should be no less than 50CM gap around the product (front, back, left, and right), and the height should be no less than 100cm..

### 6.2 Instructions for use



Place the instrument on a hard, firm surface before handling, keep it horizontal; a certain gap should be left around the instrument. The glassware set may exceed the height of the instrument; the product must be used under certain conditions of use; ensure that the instrument does not move due to vibration when it is turned on.

#### 6.2.1 Setting order of each function



1. After the controller is powered on, it passes the self-test., the TIME window displays the setting time; the REV window of the LCD displays the measured speed, TEMP displays the measured temperature (no displayed when there is no temperature), the REV SET area displays the setting speed, and the TEMP SET

area displays the setting temperature.; this state is a standard state;

2. Speed temperature setting: Click the knob to set the time, speed, and temperature. Press the knob and hold on it will return to the initial interface.

3. Run, stop: click “” key, switch between allowing heating and stopping heating, click “” key, switch between allowing motor running and stop.

4. Self-tuning function: If the temperature control effect is not ideal, please start auto-tuning. In standard state, press temperature running key more than 3 seconds, The (4) area flashes and the controller enters the self-tuning, the temperature fluctuates through three rounds, after auto-tuning will get a new set of PID parameters, the controller is controlled by the new PID parameters. In the auto-tuning, press the temperature running and hold on to exit the auto-tuning.

5. Lift function: When in the standard state, press the “” key to rise; press the “” key to decrease;

6. Turn the knob to the right to increase the digit; the left turn to decrease the digit.

### 6.2.2 Internal parameter setting

In the standard state, press function key and hold on, until the LCD displays the “LK” code, enter the password into the parameter setting interface.

(1) When PV window display “LK”, Press increase, decrease or shift key to set LK=3, Press function set to enter user operation parameter setting interface.

(2) When PV window display “LK”, set LK=68, press function to enter manufacturer speed control parameter setting interface;

Table 2

Prompt	Name	Setting Range	Description	Initial value
Pr	Speed proportion	2-1000	The smaller value of Pr, the stronger the proportional effect, but if too small, it is easy to cause shock	
ZF	Forward rotate and reverse rotate setting	0-1	0: Forward rotate 1: reverse rotate	
rA	Motor starting voltage percentage	0~50	The voltage required to start the motor relative to the rated voltage	

rP	Number of pulses per revolution	1-20	The high voltage drive board is the motor pole number *3	
Cc	Gear reduction ratio	1. 0-20. 0	Gear reduction ratio	
rn	Max. speed	40-300	Setting max. rotational speed,	

(3) When PV window display “LK”, setting LK=18, press function key to enter manufacturer parameter setting interface

Table 3

Prompt	Name	Setting Range	Description	Initial value
AL	Alarm setting	0.0~50.0	When temperature value more than SP+AL, The alarm indicator lights up, the buzzer sounds, the alarm is normally open and closed, and the alarm is normally closed.	
P	proportional band	2.0~60.0	Proportional effect adjustment , the larger the P, the smaller the proportional effect	
I	Integration time	0~3600s	Integral effect time constant, the larger I, the weaker the integral action	
d	Differential time	0~3600s	The differential effect time constant, the larger d, the stronger the differential action,	
Ar	Overshoot suppression	0~100%	Integral limit	
T	Heating cycle	1~100s	relay output ≤20s, SSR and silicon-controlled switch ≤2s,	

(4) When PV window display “LK”, setting LK=168, press enter key to enter factory parameter setting interface

Table 4

Prompt	Name	Setting Range	Description	Initial value
dy	Motor shutdown processing	0-1	0: Immediate shutdown; 1: Stop automatically after reducing the speed	0
tr	Timing	0-1	0: Timing for speed 1: Timing for temp.	0
Hd	Hold on after timing	0-1	0: Stop after timing 1: Keep working if no timing	0



uP	Rising motor after timing	0-1	0: no work 1: Automatically rise to the highest point	0
EA	Dry burning sensor selection	0-1	0: No dry burning sensor 1: Has dry burning sensor	1
cf	Fahrenheit, centigrade	0-1	0: Fahrenheit 1: centigrade	0
dP	decimal point	0-1	0: 1:	1
rL	Lower range limit	-60.0-300.0	Water temp. measurement lower limit	0.0
rH	Upper range limit	-60.0-300.0	Water temp. measurement upper limit	99.9
AP	Dry burning protection point	-60.0-300.0	Dry burn sensor is higher than this setting, no heating and will alarm	300.0

## 7. Troubleshooting

Table 5

Symptoms	Reason of failure	Troubleshooting method
Turn on the power switch light does not light	The power plug is unplugged or plugged not well. (When connected to the water bath, please also confirm the water bath power connection)	Set the power switch to the OFF position("0") then inserting the power plug into the socket.
	Plug the power cord from the fuse with the power base off or not inserted tight.	Set the power switch to the OFF position ("0"), and then plug the power cord into the power cord holder.
	Power is not applied	Please open the switchboard protection switch
	Power switch has failed.	Please stop using it immediately and contact the dealer or the nearest service center of this product.
	Circuit board failure.	
Power switch indicator light, but does not rotate.	Fuse is blown due to overload. (Short circuit)	Please stop using it immediately and contact the dealer or the nearest service center of this product.
	Rusty bearings	
	The motor has failed	
Evaporating flask oscillation	Circuit board failure.	Re-install
	内 Internal gear wear	
	The installation for Evaporating flask is not good	

	The screw for evaporating flask is unlock	Pls lock it
Abnormal sounding	Seal wear.	Please replace the seal
	Internal gear wear.	Please stop using it immediately and contact the dealer or the nearest service center of this product.
	Drive lack of oil.	
	The motor has failed	
Noise from the seal ring.	Seal with the rotating shaft with poor contact.	Please apply a thin layer of vacuum grease or water on the seal ring.
Pressure leak vacuum is not good	Rotating connection shaft wear.	Please replace the rotary connection shaft.
	Seal wear	Please replace the seal.
	Bad seal installation. (Opposite direction)	Please refer to the seal installation method, re-install.
	Decompression with gas nozzle gasket aging.	Please replace the air nozzle seal gasket.
	Vacuum hose aging	Please replace the vacuum hose.

## 8. Maintenance

1. Please do not disassemble the device, the device has a voltage or high temperature inside the part, such as disassembly dismantling device, will cause personal injury.
2. Please use the correct method and supplies appliances for cleaning and maintenance of this product. Do not spill water directly onto the product, or use abrasive powders, thinners, petroleum, kerosene, acid substances and the like, otherwise accidents such as electric shock may occur.
3. Please turn off the power switch before maintenance, unplug the power plug from the socket.
4. Cleaning, please wring the water wipe soft cloth, the dirt that not easy to remove, please use a neutral detergent, use a rag wipe clean after using detergent.
5. Carefully check before using equipment, if the glass bottles are damaged, the interface is consistent, pay attention to gently.
6. Wipe the interface with a soft cloth (disposable paper towels), and then apply a small amount of vacuum grease. After the use of vacuum grease must be covered well to prevent lime sand into.
7. The interface could not be screwed too tight, to loosen the active regularly, to avoid

- long-term tight connector killed.
8. First turn on the power switch, and then let the machine run from slow to fast, stop when the machine is in a stopped state, and then off the switch.
  9. Fasteners could not be tightened everywhere, easy to damage the glass.
  10. After each use must be wiped with a soft cloth to stay in the surface of the machine a variety of oil stains, solvent left, keep clean.
  11. Loosen the fasteners around the machine once downtime, long-term still in the working state will make the ring deformation.
  12. Regular cleaning of the glass axis of rotation, the method is: Remove the ring, check the shaft is dirt, wipe clean with a soft cloth, and then apply a small amount of vacuum grease, re-install, keep the shaft and the seal smooth.
  13. Electrical parts must not be water, strictly prohibited damp.

## Packing List

Product name: **Rotary Evaporator**

Serial no.	Category	Name	Unit	Quantity	Remarks
1	Components	Host	Set	1	
2	Components	Pole	Pc	1	
3	Components	Glassware	Set	1	Evaporating flask, Receiving flask, Main and secondary vertical condense, Rotating shaft , replenishment valves, fixing flange, seal ring
4	Components	Clamp holder	Set	1	
5	Components	Bracket	Set	1	
6	Spare parts	Nozzle SET	Pc	5	
7	Spare parts	Fuse	Pc	1	
8	Document	Use manual	Copy	1	
12	Document	Packing list	Copy	1	