

ROBUST AND EASY TO USE SNAPLOCK BRACE GRASPER



LOAD RATING



COMPLIES TO AS/NZS 1576

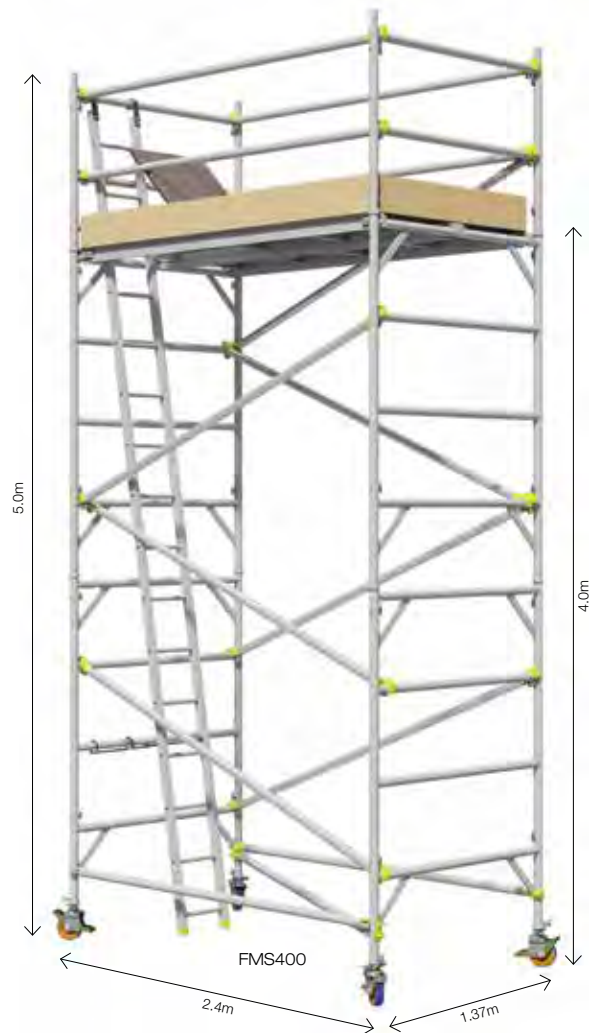

SINGLE WIDTH 0.8M X 2.4M LONG PLATFORM

SMS200 Platform Height 2m Overall Height 3m Reach Height 4m	SMS300 Platform Height 3m Overall Height 4m Reach Height 5m	SMS400 Platform Height 4m Overall Height 5m Reach Height 6m	SMS500 Platform Height 5m Overall Height 6m Reach Height 7m

SINGLE WIDTH 0.8M X 3.0M LONG PLATFORM

SMS210 Platform Height 2m Overall Height 3m Reach Height 4m	SMS310 Platform Height 3m Overall Height 4m Reach Height 5m	SMS410 Platform Height 4m Overall Height 5m Reach Height 6m	SMS510 Platform Height 5m Overall Height 6m Reach Height 7m

H-FRAME SCAFFOLD SYSTEMS

INDUSTRIAL HEAVY DUTY H FRAME SCAFFOLD TOWERS SINGLE WIDTH 0.8M X 2.4M LONG PLATFORM

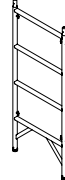
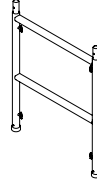
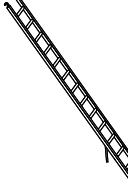
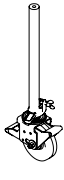
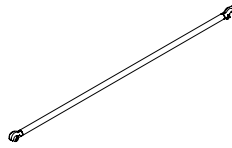
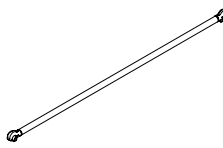
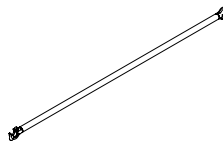
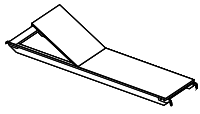
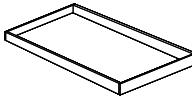
SMS200	INCLUDES
<p>Reach Height 4m</p>  <p>Overall Height 3m Platform Height 2m</p>	<div style="display: flex; flex-wrap: wrap; justify-content: space-around;"> <div style="text-align: center;">  <p>2X FHM800 Multi-Crossmember Frame</p> </div> <div style="text-align: center;">  <p>2X HFF800 Half H Frame</p> </div> <div style="text-align: center;">  <p>1X LDR322 2.85m Clip-on Ladder</p> </div> <div style="text-align: center;">  <p>4X MCA620 HF Castor - Adjustable Height</p> </div> </div> <div style="display: flex; flex-wrap: wrap; justify-content: space-around; margin-top: 20px;"> <div style="text-align: center;">  <p>3X ACB110 2.4m Aluminium Cross Brace</p> </div> <div style="text-align: center;">  <p>6X GRB420 2.4m Grasper Guardrail</p> </div> <div style="text-align: center;">  <p>1X PBA800 2.4m Planbrace</p> </div> <div style="text-align: center;">  <p>1X PFA465 2.4m Access Platform</p> </div> </div> <div style="text-align: center; margin-top: 20px;">  <p>1X TBP800 2.4m Toe Board Set</p> </div>
REACH HEIGHT 4M	

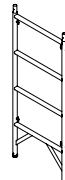
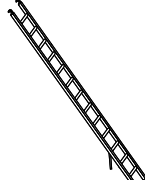
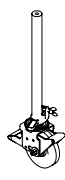
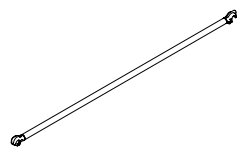
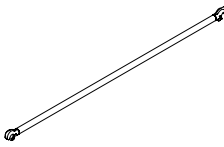
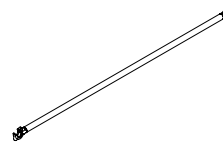
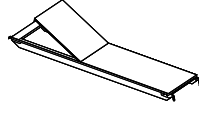
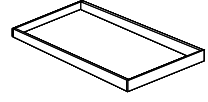
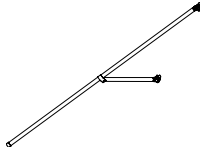
SMS300	INCLUDES
<p>Reach Height 5m</p>  <p>Overall Height 4m Platform Height 3m</p>	<div style="display: flex; flex-wrap: wrap; justify-content: space-around;"> <div style="text-align: center;">  <p>4X FHM800 Multi-Crossmember Frame</p> </div> <div style="text-align: center;">  <p>1X LDR323 3.9m Clip-on Ladder</p> </div> <div style="text-align: center;">  <p>4X MCA620 HF Castor - Adjustable Height</p> </div> <div style="text-align: center;">  <p>5X ACB110 2.4m Aluminium Cross Brace</p> </div> </div> <div style="display: flex; flex-wrap: wrap; justify-content: space-around; margin-top: 20px;"> <div style="text-align: center;">  <p>6X GRB420 2.4m Grasper Guardrail</p> </div> <div style="text-align: center;">  <p>1X PBA800 2.4m Planbrace</p> </div> <div style="text-align: center;">  <p>1X PFA465 2.4m Access Platform</p> </div> <div style="text-align: center;">  <p>1X TBP800 2.4m Toe Board Set</p> </div> </div> <div style="text-align: center; margin-top: 20px;">  <p>2X ORG705 3.0m Outrigger</p> </div>
REACH HEIGHT 5M	





SMS400	INCLUDES
<p>Reach Height 6m</p> <p>Overall Height 5m Platform Height 4m</p>	<p>4X FHM800 Multi-Crossmember Frame</p> <p>2X HFF800 Half H Frame</p> <p>1X LDR324 4.8m Clip-n Ladder</p> <p>4X MCA620 HF Castor - Adjustable Height</p>
	<p>7X ACB110 2.4m Aluminium Cross Brace</p> <p>6X GRB420 2.4m Grasper Guardrail</p> <p>1X PBA800 2.4m Planbrace</p> <p>1X PFA465 2.4m Access Platform</p> <p>1X TBP800 2.4m Toe Board Set</p> <p>2X ORG705 3.0m Outrigger</p>
REACH HEIGHT 6M	

SMS500	INCLUDES
<p>Reach Height 7m</p> <p>Overall Height 6m Platform Height 5m</p>	<p>6X FHM800 Multi-Crossmember Frame</p> <p>1X LDR325 5.8m Clip-on Ladder</p> <p>4X MCA620 HF Castor - Adjustable Height</p> <p>9X ACB110 2.4m Aluminium Cross Brace</p>
	<p>6X GRB420 2.4m Grasper Guardrail</p> <p>1X PBA800 2.4m Planbrace</p> <p>1X PFA465 2.4m Access Platform</p> <p>1X TBP800 2.4m Toe Board Set</p> <p>2X ORG705 3.0m Outrigger</p>
REACH HEIGHT 7M	

H-FRAME SCAFFOLD SYSTEMS

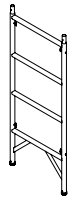
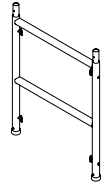
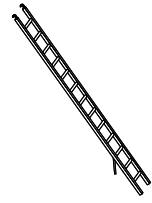
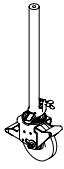
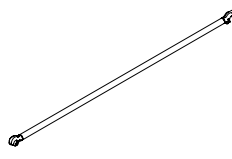
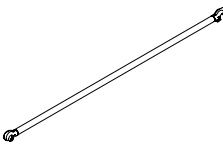
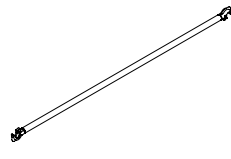
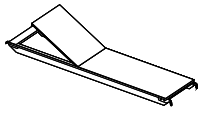
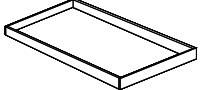
INDUSTRIAL HEAVY DUTY H FRAME SCAFFOLD TOWERS SINGLE WIDTH 0.8M X 3.0M LONG PLATFORM

SMS210	INCLUDES
<p>Reach Height 4m</p>  <p>Overall Height 3m Platform Height 2m</p>	<div style="display: flex; flex-wrap: wrap; justify-content: space-around;"> <div style="text-align: center;">  <p>2X FHM800 Multi-Crossmember Frame</p> </div> <div style="text-align: center;">  <p>2X HFF800 Half H Frame</p> </div> <div style="text-align: center;">  <p>1X LDR322 2.85m Clip-on Ladder</p> </div> <div style="text-align: center;">  <p>4X MCA620 HF Castor - Adjustable Height</p> </div> </div> <div style="display: flex; flex-wrap: wrap; justify-content: space-around; margin-top: 10px;"> <div style="text-align: center;">  <p>3X ACB310 3.0m Aluminium Cross Brace</p> </div> <div style="text-align: center;">  <p>6X GRB430 3.0m Grasper Guardrail</p> </div> <div style="text-align: center;">  <p>1X PBA810 3.0m Planbrace</p> </div> <div style="text-align: center;">  <p>1X PFA470 3.0m Access Platform</p> </div> </div> <div style="text-align: center; margin-top: 10px;">  <p>1X TBP810 3.0m Toe Board Set</p> </div>
REACH HEIGHT 4M	

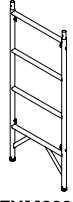
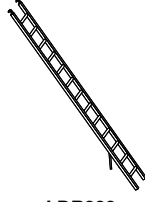
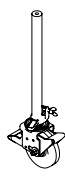
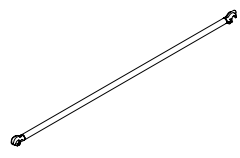
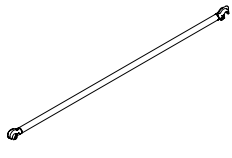
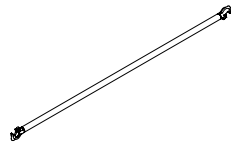
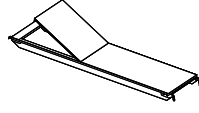
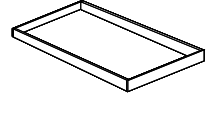
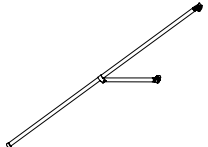
SMS310	INCLUDES
<p>Reach Height 5m</p>  <p>Overall Height 4m Platform Height 3m</p>	<div style="display: flex; flex-wrap: wrap; justify-content: space-around;"> <div style="text-align: center;">  <p>4X FHM800 Multi-Crossmember Frame</p> </div> <div style="text-align: center;">  <p>1X LDR323 3.9m Clip-on Ladder</p> </div> <div style="text-align: center;">  <p>4X MCA620 HF Castor - Adjustable Height</p> </div> <div style="text-align: center;">  <p>5X ACB310 3.0m Aluminium Cross Brace</p> </div> </div> <div style="display: flex; flex-wrap: wrap; justify-content: space-around; margin-top: 10px;"> <div style="text-align: center;">  <p>6X GRB430 3.0m Grasper Guardrail</p> </div> <div style="text-align: center;">  <p>1X PBA810 3.0m Planbrace</p> </div> <div style="text-align: center;">  <p>1X PFA470 3.0m Access Platform</p> </div> <div style="text-align: center;">  <p>1X TBP810 3.0m Toe Board Set</p> </div> </div> <div style="text-align: center; margin-top: 10px;">  <p>2X ORG705 3.0m Outrigger</p> </div>
REACH HEIGHT 5M	

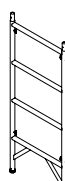
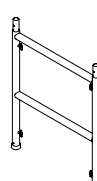
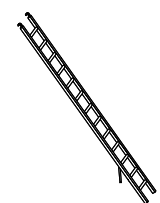
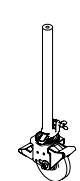
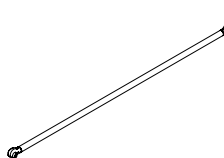
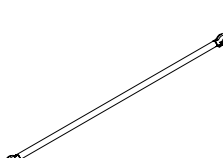
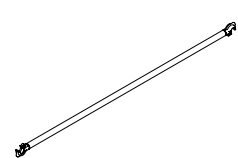
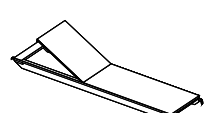
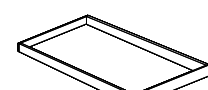
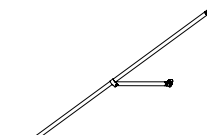

SMS410	INCLUDES			
 <p>Reach Height 6m</p> <p>Overall Height 5m</p> <p>Platform Height 4m</p>	 4X FHM800 Multi-Crossmember Frame	 2X HFF800 Half H Frame	 1X LDR324 4.8m Clip-n Ladder	 4X MCA620 HF Castor - Adjustable Height
	 7X ACB310 3.0m Aluminium Cross Brace	 6X GRB430 3.0m Grasper Guardrail	 1X PBA810 3.0m Planbrace	 1X PFA470 3.0m Access Platform
	 1X TBP810 3.0m Toe Board Set	 2X ORG705 3.0m Outrigger		
REACH HEIGHT 6M				

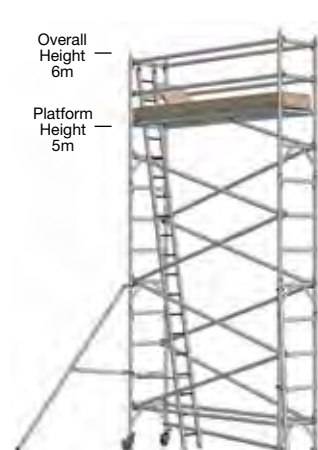
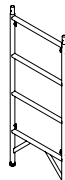
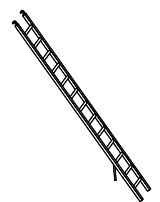
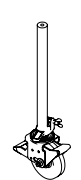
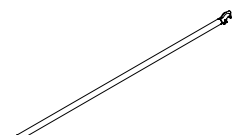
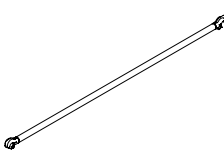
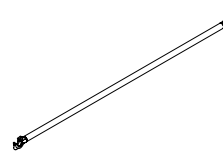
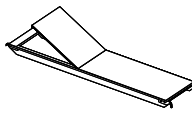
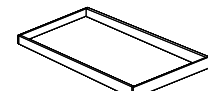
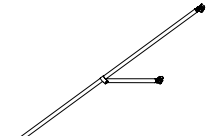
SMS510	INCLUDES			
 <p>Reach Height 7m</p> <p>Overall Height 6m</p> <p>Platform Height 5m</p>	 6X FHM800 Multi-Crossmember Frame	 1X LDR325 5.8m Clip-on Ladder	 4X MCA620 HF Castor - Adjustable Height	 9X ACB310 3.0m Aluminium Cross Brace
	 6X GRB430 3.0m Grasper Guardrail	 1X PBA810 3.0m Planbrace	 1X PFA470 3.0m Access Platform	 1X TBP810 3.0m Toe Board Set
	 2X ORG705 3.0m Outrigger			
REACH HEIGHT 7M				

LONG SPAN H FRAME PLATFORM JOINS TWO TOWERS TOGETHER FOR LONGLINE ACCESS

FEATURES & BENEFITS

- 3m - 6m long span platform, set up in minutes
- 225kg load rating
- Lightweight and easy to handle
- Cover more area efficiently
- 2x longspan platforms fit side by side for a fully decked platform

Code	Description	Length
LSP300	3m Long Span	3.0m
LSP400	4m Long Span	4.0m
LSP500	5m Long Span	5.0m
LSP600	6m Long Span	6.0m
LSH300	3m Longspan Handrail	3.0m
LSH400	4m Longspan Handrail	4.0m
LSH500	5m Longspan Handrail	5.0m
LSH600	6m Longspan Handrail	6.0m
LSP100	Longspan 'F' Post	-
LSP150	Longspan Single Post	-



* Toeboards omitted for clarity

F POST



SINGLE POST



ALUMINIUM 'Z' STAIRS

FEATURES & BENEFITS

- Used with Easy Access heavy duty H-Frames
- Much safer to use than ladders, carry tools and equipment easily
- Lightweight - easy one man handling
- Fast - dramatically increases scaffolding efficiency

Code	Description	Length
STR310	Stair - Fits 2.4m Bay Length	2.4m
STR320	Stair - Fits 3.0m Bay Length	3.0m
STH310	Stair External Handrail	2.4m
STH320	Stair External Handrail	3.0m
STI310	Stair Internal Handrail	2.4m
STI320	Stair Internal Handrail	3.0m

* Customised lengths and widths available



CLIP-ON ROLLING TOWER EXTENSION LADDER

FEATURES & BENEFITS



- Used with Easy Access heavy duty H-Frames
- Compacts for easy handling and transportation - No longer need an unwieldy 6m long ladder on the roof rack for a 5m tower
- Lightweight and robust aluminium construction
- Extends to different height settings
- Adjustable brace to compensate when the ladder is at different heights
- Attaches to Easy Access H-Frames using hooks

Code	Description	Length
LDF323-4E	Clip-on rolling tower extension ladder	3-4m
LDF324-6E	Clip-on rolling tower extension ladder	4-6m





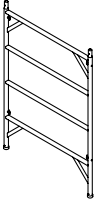
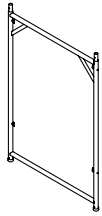
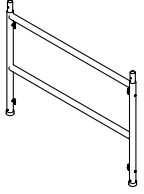
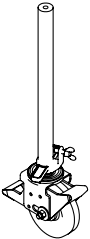
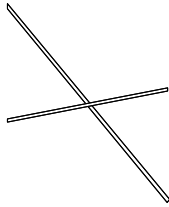
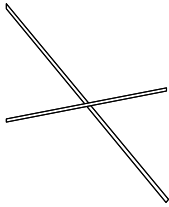

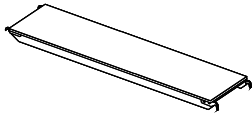
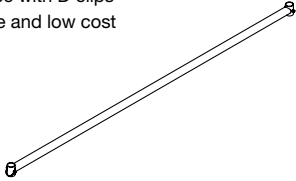
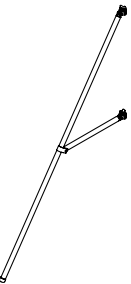
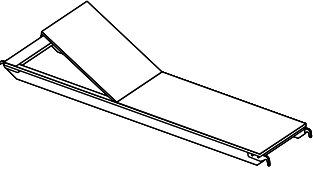
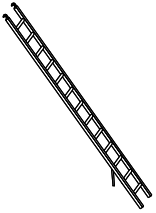
INDUSTRIAL SCAFFOLD SYSTEMS ACCESSORIES

HEAVY DUTY H FRAME COMPONENTS

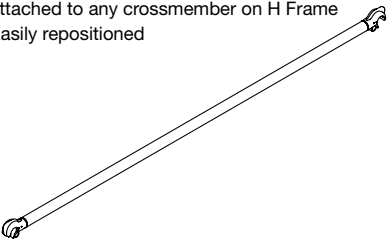
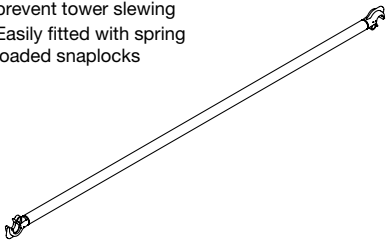
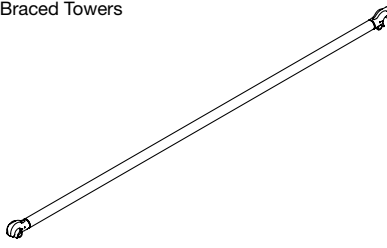
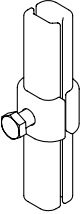
END FRAME		END FRAME (WALK THROUGH)		HALF H FRAME	
<ul style="list-style-type: none"> • 1.9m High • Four Rails 500mm apart • Planks and platforms can be placed on all levels 		<ul style="list-style-type: none"> • 2m High • Designed to give walk-through head clearance • Bottom tie-rail provides durability • Weighs 8kg 		<ul style="list-style-type: none"> • 950mm High • Can serve as either guardrails or as a half stage platform level 	
CODE	DESCRIPTION	CODE	DESCRIPTION	CODE	DESCRIPTION
FHM150	Double Width End Frame	FHF150	Double width End Frame (Walk Through)	HFF250	Double Width Half End Frame
FHM800	Single Width End Frame	FHF800	Single Width End Frame (Walk Through)	HFF800	Single Width Half End Frame
ADJUSTABLE HEIGHT CASTORS		CROSS BRACE FOR 2.4M PLATFORM		CROSS BRACE FOR 3.0M PLATFORM	
<ul style="list-style-type: none"> • Rated at 500kgs • Fully braked • Positive braking • Low maintenance • Non-marking wheels 		<ul style="list-style-type: none"> • Galvanised steel scissor brace adds strength and durability to the system • Colour coded for easy identification 		<ul style="list-style-type: none"> • Braces lock to frame on "drop-lock" latches • Braces fold flat for easy storage and handling • Colour coded for easy identification 	
CODE	DESCRIPTION	CODE	DESCRIPTION	CODE	DESCRIPTION
MCA620	150mm Diam	CBF110	Walk-through Frame Cross Brace	CBF310	Walk-through Frame Cross Brace
CA200	200mm Diam	CBM110	Cross Member Cross Brace	CBM310	Multi Cross Member Cross Brace
		CBH210	Half Frame Cross Brace	CBH310	Half Frame Cross Brace
GUARDRAIL POST		STANDARD PLATFORM		SLEEVE GUARDRAIL	
<ul style="list-style-type: none"> • Supports guardrails on multi-bay arrangements • Allows walk-through access at top platform level 		<ul style="list-style-type: none"> • Aluminium subframe with plywood decking hook onto any crossmembers • Works as extra ledger type bracing making scaffold more rigid • Lightweight 		<ul style="list-style-type: none"> • Fits over H Frame spigots and are locked in place with D clips • Simple and low cost 	
CODE	DESCRIPTION	CODE	DESCRIPTION	CODE	DESCRIPTION
GPA450	Guardrail Post	PFS435	Standard Platform 600mm x 2.4m long	GRA405	Sleeve Guardrail 2.4m long
		PFS440	Standard Platform 600mm x 3m long	GRA410	Sleeve Guardrail 3m long
OUTRIGGER		ACCESS PLATFORM		LADDERS	
<ul style="list-style-type: none"> • Stabilise scaffold when setup over the 3:1 ratio of height to base width • Easily fitted with hand tightened couplers 		<ul style="list-style-type: none"> • Hatch opening allows ladder to be put through • Hatch locks down when not in use so will not flap open accidentally 		<ul style="list-style-type: none"> • Top hooks locate over crossmembers • Two struts hold ladder at required slope & clip to lower frame 	
CODE	DESCRIPTION	CODE	DESCRIPTION	CODE	DESCRIPTION
ORG705	3m Outrigger (Each)	PFA465	Access Platform 600mm x 2.4m long	LDR322	2.85m Ladder
		PFA470	Access Platform 600mm x 3m long	LDR323	3.9m Ladder
				LDR324	4.8m Ladder
				LDR325	5.8m Ladder

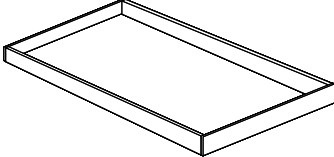
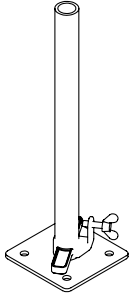
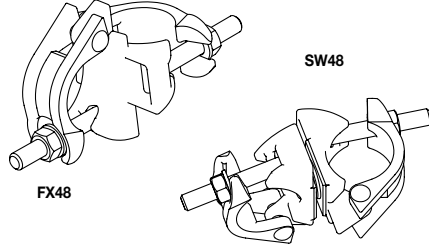
HEAVY DUTY H FRAME COMPONENTS

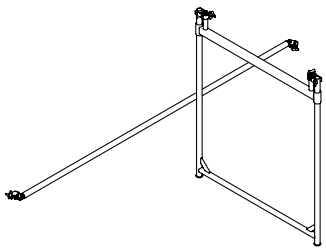
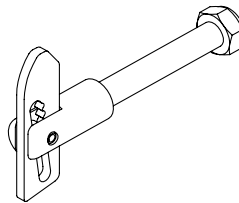
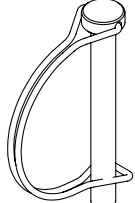
SNAPLOCK GUARDRAIL		PLANBRACE		DIAGONAL BRACE	
<ul style="list-style-type: none"> Snap-on couplers allow guardrail to be attached to any crossmember on H Frame Easily repositioned 		<ul style="list-style-type: none"> Required when using castors to prevent tower slewing Easily fitted with spring loaded snaplocks 		<ul style="list-style-type: none"> To fit SMS and FMS Snaplock Braced Towers 	
CODE	DESCRIPTION	CODE	DESCRIPTION	CODE	DESCRIPTION
GRB420	Snaplock Guardrail 2.4m long	PBA755	Planbrace 2.4m long	ACB110	Diagonal Brace for 2.4mL Platform
GRB430	Snaplock Guardrail 3m long	PBA765	Planbrace 3m long	ACB310	Diagonal Brace for 3mL Platform
LOCKING SPIGOT		PLANKS		TOEBOARDS	
		<ul style="list-style-type: none"> Laminated High strength and durability 		<ul style="list-style-type: none"> Required where there is a risk of people or objects falling from 2m or more Quickly attached to platform 	
CODE	DESCRIPTION	CODE	DESCRIPTION	CODE	DESCRIPTION
IN48	Locking Spigot	PLW470	Wood 3m Long	TBP510	Toeboards for 2.4mL Platform (set of 4)
TBP520	Toeboards for 3mL Platform (set of 4)				
BASE PLATE ADJUSTABLE		COUPLINGS		ALUMINIUM TUBE	
<ul style="list-style-type: none"> Height adjustment of 300mm Screw thread for fine adjustment Held captive to frame so will not drop out when frame is lifted 		 <p>FX48</p> <p>SW48</p>		<ul style="list-style-type: none"> Standard scaffold diameter tube With use of the tube and coupler the system is very adaptable to most situations 	
CODE	DESCRIPTION	CODE	DESCRIPTION	CODE	DESCRIPTION
BPA605	Base Plate Adjustable	FX48	Fixed 90° Coupling	ALT740	Aluminium Tube
		SW48	Swivel Coupling		
H FRAME ALL TERRAIN BASE PACK		HF GRAVITY LATCH		D CLIPS	
					
CODE	DESCRIPTION	CODE	DESCRIPTION	CODE	DESCRIPTION
MATB30	H Frame All Terrain Base Pack	HFGRAVITY	Anti Luce Bolt	DCLIPS	5/16 Shaft Locking Pins

LADDERS

Easy Access has the widest range of ladders available in NZ. Robust and compliant to keep you, your team and your family safe when working at height on sites and at home, no matter what the job.

For compliant use on a trade site, the minimum recommended weight rating for a ladder is 150kg, and the ladder must display an "Industrial" label.

Easy Access Warthog, Trade Series aluminium and fibreglass ladders are rated up to a huge 200Kg SWL.

For household use and light industrial tasks, we have a handy 120Kg rated ladder range.

To extend the life of your ladders, replacement feet are available for all Easy Access Ladders.



**New Zealand's
widest range
of *LADDERS***

LADDER USE

SAFETY GUIDELINES

INDUSTRIAL LABEL FOR TRADE SITES

Ladders must have an “Industrial” label to be compliant for trade sites. A minimum weight rating of 150kg is recommended for trade.

SAFE ANGLE OF SLOPE

The ratio of height to horizontal distance out from the vertical support surface of any single pole or extension ladder is from 1:4 to 1:6.

LADDER USE DURATION

Ladders are to be used only for tasks of short duration which would normally be less than 10 minutes.

PLATFORM LADDERS ARE PREFERABLE

Platform ladders are recommended for tasks longer than 5 mins because they provide 3 points of contact, a stable working platform and a handrail. An AdjustaStep Platform ladder provides additional versatility with adjustable platform heights.

LADDERS ON TRADE SITES

Platform ladders are the only ladder type permissible on many worksites.

FOLD-OUT STEP/EXTENSION LADDERS

Look for trapezoidal steps on dual purpose ladders for a comfortable and rigid step in both step and single ladder positions.

LADDER COMPLIANCE

The standard of compliance for portable ladders is AS 1892.



NB. Worksite compliance and safety requirements may vary, check with your site supervisor for clarification.

TRADE SERIES LADDERS



180KG RATED DOUBLE SIDED STEP LADDER

- Heavy duty ladder feet - the fastest-wearing part of a ladder
- Non-clogging hinge - won't jam up with plaster spills
- Stainless steel rivets with extra large heads for maximum durability
- Internal side stay prevents damage during transport
- Replacement feet available
- Superior bracing system



COMPLIES TO
AS/NZS
1892 : 2018



Code	Barcode	Description	Height	Stance Width	Load Rating	Weight
OXDS02	9341231026126	2 Step	0.6m	0.39m	180Kg	6.0Kg
OXDS03	9341231013188	3 Step	0.9m	0.42m	180Kg	7.1Kg
OXDS04	9341231013195	4 Step	1.2m	0.46m	180Kg	8.1Kg
OXBOH		Optional bolt on Handrail				
OXSEFT		Replacement feet (ea)				

150KG RATED DUAL PURPOSE LADDER

- Hard-wearing feet - the fastest-wearing part of a ladder
- Internally braced side arms - improves stability and doubles as a handy tool tray
- Trapezoidal back steps - comfortable to use in either 'A' shape or folded out into a single ladder configuration
- Stainless steel rivets with extra large heads for maximum durability
- Secure locking latch - guards against accidental dislodgement
- Replacement feet available



COMPLIES TO
AS/NZS
1892 : 2018

Code	Barcode	Description	Length	Stance Width	Load Rating	Weight
OXSE06	9341231026256	6 Step	1.8m - 3.3m	0.55m	150Kg	11.0Kg
OXSE07	9341231026263	7 Step	2.1m - 3.9m	0.60m	150Kg	12.0Kg
OXSE08	9341231026270	8 Step	2.4m - 4.5m	0.63m	150Kg	13.0Kg
OXSEFT		Replacement feet (ea)				



180KG RATED TRADE SERIES PLATFORM LADDER

- Large non-slip platform surface for added safety when working at heights
- Simply folds out giving a well braced platform and folds flat for storage
- Wide, trapezoidal box step for high torsional strength
- Plastic molded handrail doubles as a handy tool tray
- Robust leg bracing for added strength and stability
- Central stay arm under platform - no pinch points
- Replacement feet available



COMPLIES TO
AS/NZS
1892 : 2018

Code	Barcode	Description	Height*	Stance Width	Overall Stile Length	Load Rating	Weight
OXPL02	9341231026317	2 Step	0.56m	0.54m	1.6m	180Kg	10.4Kg
OXPL03	9341231026324	3 Step	0.85m	0.59m	1.9m	180Kg	12.0Kg
OXPL04	9341231026331	4 Step	1.13m	0.63m	2.2m	180Kg	14.7Kg
OXPL05	9341231026348	5 Step	1.41m	0.67m	2.5m	180Kg	16.2Kg
OXPL06	9341231026355	6 Step	1.69m	0.71m	2.8m	180Kg	18.2Kg
OXPL08	9341231026379	8 Step	2.26m	0.80m	3.4m	180Kg	20.2Kg
OXPLFT		Replacement feet front (pair)					
OXPLFTR		Replacement feet rear/stair side (pair)					
OXPLFSH		Handrail					

* Heights show dimensions from floor to top of platform



TRADE SERIES LADDERS

TRADE SERIES PLATFORM LADDER FEATURES AND ACCESSORIES

- Optional full surround locking handrail
- Optional clip-on tool bucket
- Optional spring loaded wheels for mobility
- Designed to easily roll on hard floors
- Ideal for a warehouse situation

KEY COMPONENTS

Code	Description
A	Cross Bracing
B	Anti-Slip Deck
C	Molded Rubber Feet
D	Trapezoidal Box Step For Torsional Strength
E	Central Stay Arm
F	Safety Guardrail with Molded Tool Tray
G	Push Rod Easy Fold System
H	Robust Leg Bracing
I	Optional Full Surround Locking Handrail
J	Optional Clip-on Tool Bucket
K	Optional Spring Loaded Wheel

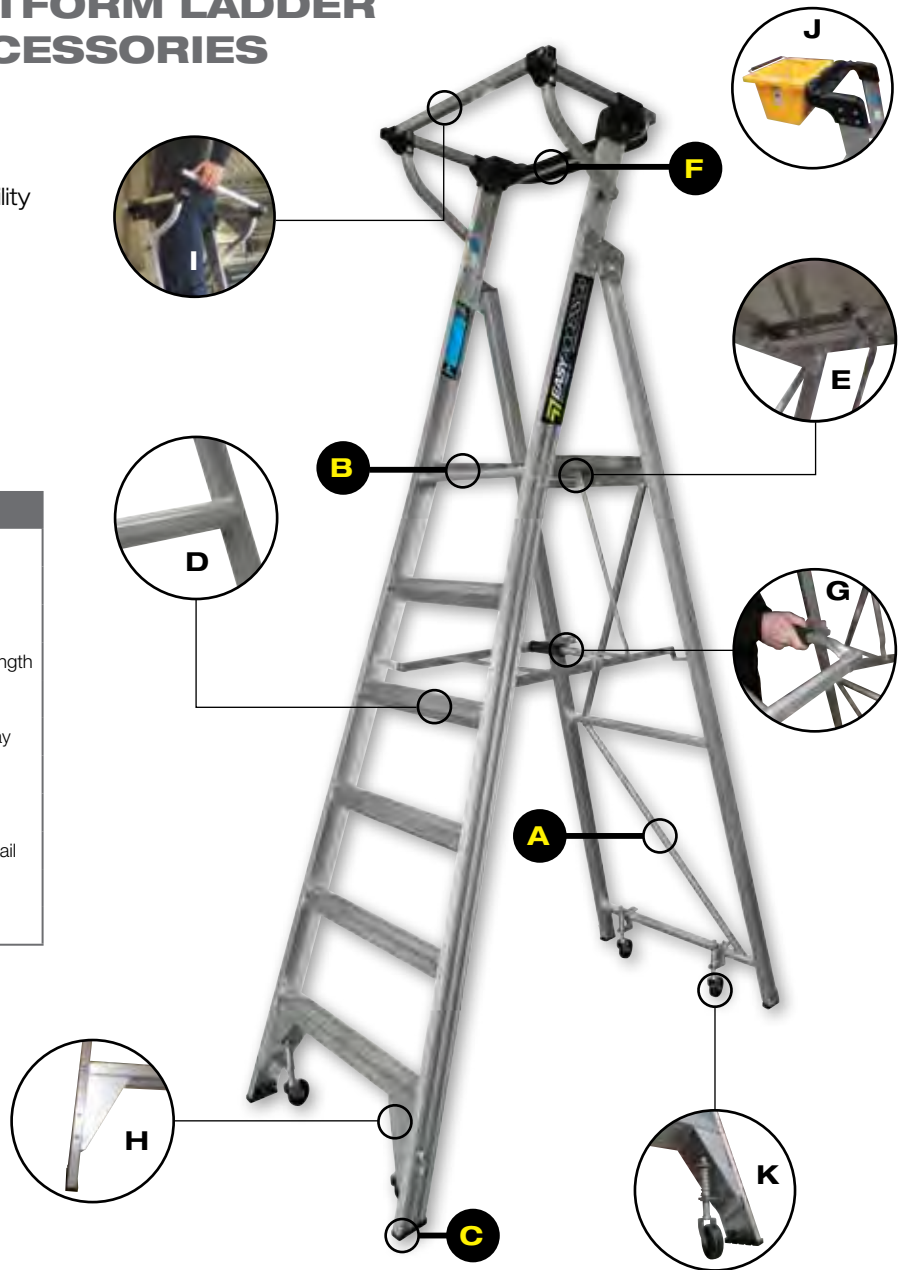

Code	Description	Features
OXPLFSH	Full surround handrail	"Safer for longer duration use Click-in locking mechanism for ease of use Slides up when not in use for flat folding of the ladder and handrail"
OXPLTT	Optional Clip-on tool bucket	For more storage capacity, use a clip-on tool bucket Reduces time-consuming descending and re-climbing to fetch tools and equipment.
OXPLW	Platform Ladder Wheel set of 4	Optional spring loaded wheels attached to the base to improve the mobility of the ladder Spring mechanism disengages wheels when ladder in use

200KG RATED ADJUSTASTEP TELESCOPIC PLATFORM LADDER

FEATURES & BENEFITS

- Height adjustable for working off a large safe platform at variable heights. One ladder fits all!
- Set front and back stiles to varying heights for working on steps or uneven ground
- Platform heights adjusted through each ladder's range in seconds
- Handrail allows for 3 points of contact
- Large hard-wearing rubber feet for stable grip
- Rated to 200kg for industrial applications
- Once-piece, smooth operation – simply folds flat and locks
- Can be fitted with accessories – tool bucket and full surround handrail



Optional rear lift up gate and side handrail for ultimate safety.



Optional Tool bucket.



Optional wheels for easy maneuverability.



Code	Barcode	Description	Height	Overall Stile Length	Load Rating	Weight
OXTPL03-05	9421901464783	3-5 Step	0.84m - 1.44m	1.90m - 2.39m	200kg	18.8Kg
OXTPL04-07	9421901464325	4-7 Step	1.15m - 2.02m	2.27m - 3.14m	200kg	21.1Kg
OXTPL05-09	9421901464790	5-9 Step	1.44m - 2.60m	2.50m - 3.49m	200kg	25.5Kg
OXTPLWSET		OXTPL wheel set				
OXPLFSH		Full surround handrail				
OXPLTT		Optional Clip-on tool bucket				
OXTPLFF		Replacement feet front (pair)				
OXTPLFB		Replacement feet rear (pair)				



COMPLIES TO
AS/NZS
1892 : 2018

TRADE SERIES LADDERS



ADJUSTASTEP



OXTPL03-05



OXTPL04-07



OXTPL05-09



Code	Step Adjustment	Platform Height
OXTPL03-05	3 Step	0.84m
	4 Step	1.14m
	5 Step	1.44m
OXTPL04-07	4 Step	1.15m
	5 Step	1.44m
	6 Step	1.73m
	7 Step	2.02m
OXTPL05-09	5 Step	1.44m
	6 Step	1.73m
	7 Step	2.02m
	8 Step	2.31m
	9 Step	2.60m

TRADE SERIES TELESCOPIC ALL IN ONE LADDER

150KG RATED MULTI PURPOSE

EXTENDABLE LEGS - FOR EXTRA HEIGHT ADJUSTMENT & STAIR ACCESS

- Easily seen hinge lock - it's obvious when it's engaged
- Easily operated, heavy duty height lock - simple pull out and release
- All-in-One - five different settings for every application
- Welded steps for superior strength and longevity
- Simple heavy duty pull out & release height lock
- Welded rungs for greater strength
- A ladder can be separated in 2x individual sections for a trestle and plank configuration



COMPLIES TO
AS 1892 : 2018



ADJUST FOR UNEVEN
BASE SURFACE

TRADE SERIES LADDERS



OPTIONAL CLIP-ON PLATFORM WITH TWO POSITION OPTIONS



OXTL04

Trestle configuration with a 2.2m - 4.0m long Telescopic plank. The ultimate in access versatility!



OXLBS



Code	Barcode	Description	Length	Load Rating	Weight
OXTL03	9341231026287	3 - 5 Step Telescopic	0.9m - 3.3m	150kg	12.0Kg
OXTL04	9341231026294	4 - 7 Step Telescopic	1.2m - 4.5m	150kg	15.5Kg
OXTL05	9341231026300	5 - 9 Step Telescopic	1.5m - 5.7m	150kg	18.0Kg
OXTLP	9421901768362	Clip-on Platform	N/A	N/A	N/A
OXTLFOU		Replacement feet outer L/R (pair)			
OXTLFIN		Replacement feet inner L/R (pair)			
OXLBS		Trestle Plank Bracket			

TRADE SERIES LADDERS

135KG-150KG RATED TRADE SERIES EXTENSION LADDER

SINGLE ROPE OPERATION - LEAVES ONE HAND FREE TO SUPPORT THE LADDER WHILE IT IS ADJUSTED

- Side mounted rope - avoids tripping hazard
- Triple pulley - three times easier to lift
- Auto engaging height lock - ensuring your safety
- 'D' Shape rungs - for operator comfort
- Wide heavy duty feet for increased bearing surface and durability
- Replacement ladder feet available

Code	Barcode	Description	Length	Load Rating	Weight
OXEL09	9341231026423	9 Step	2.9m - 4.7m	150Kg	13.6Kg
OXEL11	9341231026430	11 Step	3.45m - 6.0m	150Kg	16.3Kg
OXEL13	9341231026447	13 Step	4.1m - 7.2m	135Kg	18.7Kg
OXELFEET		Replacement feet (pair)			



COMPLIES TO
AS/NZS
1892 : 2018



135KG-150KG RATED TRADE SERIES EXTENSION LADDER WITH LEVELLING FEET

- Adjustable to up to 175mm variance
- Wide heavy duty feet for increased bearing surface and durability
- Simple to adjust with downward foot-force applied, till ladder foot reaches lower level
- Heavy duty stainless cable for long life
- Replacement feet available



COMPLIES TO
AS/NZS
1892 : 2018

Code	Barcode	Description	Height	Load Rating	Weight
OXEL09LFT	9421901768904	9 Step	3.19m - 4.72m	150Kg	15.0Kg
OXEL11LFT	9421901768911	11 Step	3.80m - 5.93m	150Kg	18.0Kg
OXEL13LFT	9421901768928	13 Step	4.41m - 7.15m	135Kg	21.0Kg
OXELLFTFEET		Replacement feet (pair)			

WIDE HEAVY
DUTY FEET



HEAVY DUTY CABLE



FOOT ADJUSTMENT
RELEASE

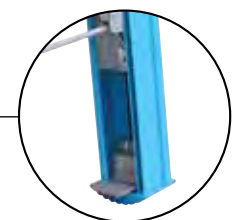

150KG RATED SINGLE LADDER

- Heavy duty 150kg rated
- Comfortable 'D' shaped rung
- Good value for money
- Lightweight and easy to use
- Replacement feet available



COMPLIES TO
AS/NZS
1892 : 2018

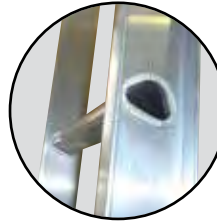

Code	Barcode	Description	Length	Load Rating
CSL3.0	9421901768805	Aluminium Straight Ladder	3.0m	150Kg
CSL3.6	9421901768812	Aluminium Straight Ladder	3.6m	150Kg
CSL4.8	9421901768829	Aluminium Straight Ladder	4.8m	150Kg
CSL5.4	9421901768836	Aluminium Straight Ladder	5.4m	150Kg
CSLFEET		Replacement feet (pair)		

150KG RATED WELDED 'D' STILE SINGLE LADDER

- Welded rungs for extra strength and rigidity
- D-Stiles - can be attached to scaffolding using standard fittings
- Flat based rubber feet - superior grip in harsh trade environments
- Replacement feet available

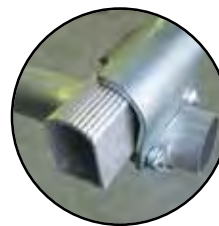

Code	Barcode	Description	Length	Load Rating
DSL3.0	9341231007750	Welded Scaffold Ladder	3.0m	150Kg
DSL3.6	9341231007767	Welded Scaffold Ladder	3.6m	150Kg
DSL4.8	9341231007774	Welded Scaffold Ladder	4.8m	150Kg
DSL5.4	9341231007781	Welded Scaffold Ladder	5.4m	150Kg
PLC4.8	9341231007798	Putlog Coupler		
DSLFEET		Replacement feet (pair)		



COMPLIES TO
AS/NZS
1892 : 2018

* Only suitable with Handrail and Safety Gate Set

WARTHOG WELDED LADDERS

180KG RATED WARTHOG DOUBLE SIDED WELDED STEP LADDER

FULLY WELDED STEPS - HIGH STRENGTH & SUPERIOR RIGIDITY

- Compact and lightweight but seriously tough
- Smooth locking mechanism that automatically engages when opened
- Non clogging hinge - opens up to allow dirt and plaster to fall away
- Box section stile and step - more robust and rigid
- Replacement feet available



LIFE WARRANTY

Code	Barcode	Description	Height	Stance Width	Load Rating	Weight
WHDS03	9421901086107	3 Step	0.9m	0.49m	180Kg	7.3Kg
WHDS04	9421901086114	4 Step	1.2m	0.66m	180Kg	9.9Kg
WHDS06	9421901086138	6 Step	1.8m	0.66m	180Kg	13.6Kg
WHDS07	9341231007415	7 Step	2.1m	0.66m	180Kg	14.2Kg
FEETCAPSWART		Replacement feet (pair)				



COMPLIES TO AS/NZS 1892 : 2018

* Extra height models available on request as a special order

180KG RATED WARTHOG WIDE DOUBLE SIDED WELDED LADDER

- 800mm wide step provides a large surface
- Much safer and easier than a saw horse
- Smooth automatic locking mechanism
- Non clogging top step hinges
- Hollow box section stile and steps for extra strength and rigidity
- Replacement feet available



LIFE WARRANTY

Code	Barcode	Description	Length	Load Rating	Weight
WHDS02-800	9421901768843	2 Step	0.6m	180Kg	10.0Kg
WHDS03-800	9341231086909	3 Step	0.9m	180Kg	11.0Kg
WHDS04-800	9341231086916	4 Step	1.2m	180Kg	12.0Kg
FEETCAPSWART		Replacement feet (ea)			



COMPLIES TO AS/NZS 1892 : 2018



180KG RATED DUAL PURPOSE WARTHOG WELDED LADDER

FULLY WELDED - THE STRONGEST LADDER FOR THE SERIOUS TRADESMAN

- Dual purpose, fold out ladder
- No protruding hooks or snag points to catch on roof racks and get damaged
- All rungs line up to form a large flat step when folded
- Same size rungs right to the top
- Will not twist - exceptional torsional strength
- Replacement feet available

BOX SECTION STILES ALMOST DOUBLE THE TORSIONAL TWIST STRENGTH OF C-SHAPED CHANNEL SECTIONS - NO NEED FOR GUSSET BRACING

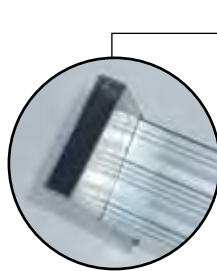

WELDED TRAPEZOIDAL STEPS. THESE WILL NEVER LOOSEN WITH WEAR AND TEAR AS SWAGED OR RIVETED STEPS DO OVER TIME. THIS FEATURE PROMISES THE OPERATOR YEARS OF RELIABLE AND SAFE USE

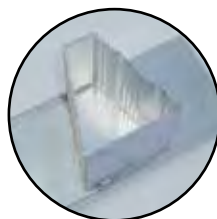

WARTHOG WELDED LADDERS



COMPLIES TO
AS/NZS
1892 : 2018

Code	Barcode	Description	Length	Stance Width	Load Rating	Weight
WHSE04	9421901086091	4 Step	1.2m - 2.1m	660mm	180Kg	8.0Kg
WHSE05	9421901086039	5 Step	1.5m - 2.7m	660mm	180Kg	9.0Kg
WHSE06	9421901086046	6 Step	1.8m - 3.3m	660mm	180Kg	10.0Kg
WHSE07	9421901086053	7 Step	2.1m - 3.9m	660mm	180Kg	11.0Kg
WHSE08	9421901086060	8 Step	2.4m - 4.5m	660mm	180Kg	12.0Kg
WHSE09	9421901086077	9 Step	2.7m - 5.4m	825mm	150Kg	13.0Kg
WHSE10	9421901086084	10 Step	3.0m - 5.7m	825mm	150Kg	14.0Kg
FEETCAPSWART		Replacement feet (pair)				



LIFE WARRANTY

WARTHOG WELDED LADDERS

200KG RATED WARTHOG WELDED PLATFORM LADDER

THE SAFEST CHOICE

- Large work platform - much safer and more user friendly when working for longer periods or handling bulky items
- One piece, smooth operation - simply folds out and locks
- Folds flat for storage
- Optional spring loaded wheels attach to the base to improve the mobility of the ladder
- Centrally mounted stay arm - no more pinch points
- Replacement feet available
- Designed to easily roll on hard floors
- Ideal for a warehouse situation

SAFE & SECURE
WORKING PLATFORM



WELDED
TRAPEZOIDAL STEPS



LARGE ANTI SLIP,
BOX SECTION
STAIR TREADS



ANTI SLIP FEET CAPS
FOR ULTIMATE STABILITY

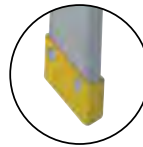

OPTIONAL SPRING
LOADED WHEELS FOR
MOBILITY



COMPLIES TO
AS/NZS
1892 : 2018



LIFE
WARRANTY

Code	Barcode	Description	Height*	Overall Stile Length	Load Rating	Weight
WHPL02	9341231007552	2 Step	0.56m	1.7m	200Kg	11.0Kg
WHPL03	9421901086527	3 Step	0.85m	2.0m	200Kg	12.0Kg
WHPL04	9421901086534	4 Step	1.13m	2.3m	200Kg	13.0Kg
WHPL05	9421901086541	5 Step	1.41m	2.6m	200Kg	14.0Kg
WHPL06	9421901086558	6 Step	1.69m	2.9m	200Kg	15.0Kg
WHPL07	9421901086565	7 Step	1.97m	3.2m	200Kg	16.0Kg
WHPL08	9421901086572	8 Step	2.26m	3.5m	200Kg	17.0Kg
WHPL09	9341231007569	9 Step	2.54m	3.8m	150Kg*	18.0Kg
WHPL10	9341231007576	10 Step	2.82m	4.1m	150Kg*	19.0Kg
FEETCAPSWART		Replacement feet (pair)				
WHPLWC		Spring Wheel to suit WHPL c/w bolts (per each wheel)				

* Black support strap needed * Heights show dimensions from floor to top of platform





WARTHOG WELDED LADDERS

22
YEARS
KEEPING TRADIES SAFE UP THERE
SINCE 1999

EASY
ACCESS Co.
Reach it the **easy** way

WARTHOG WELED LADDERS

ROOF LADDER

SAFELY CLIMB TO THE APEX OF A PITCHED ROOF

- Safe access to any roof with a pitch of up to 45 degrees
- Easy and efficient solution for roof painting and maintenance
- Simply slide the ladder on rollers and flip over to secure the hooks over the apex
- Foamed support pads maintain even and secure contact between the ladder and roof
- Foam buffer on hook absorbs any movement and protects the roof from damage
- Replacement feet available

Code	Description	Length	Load Rating
CSRL3.0	Roof Ladder	3.0m	150Kg
CSRL3.6	Roof Ladder	3.6m	150Kg
CSRL4.8	Roof Ladder	4.8m	150Kg
CSRL5.4	Roof Ladder	5.4m	150Kg
CSRL6.0	Roof Ladder	6.0m	150Kg
CSLFEET	Replacement feet (pair)		

Edge protection must be in place 2m either side of the work space (omitted from pic for clarity)



ROLLERS ALLOW EASY MOUNTING OF THE LADDER



FOAM SUPPORT PADS



150KG RATED FIBREGLASS DOUBLE SIDED STEP LADDER

- High strength fiberglass stiles
- **Electrically safe** and non-conductive
- Large brace members - maximum rigidity
- Replacement feet available



COMPLIES TO
AS/NZS
1892 : 2018



Code	Barcode	Description	Height	Stance Width	Load Rating	Weight	
OXDSF03	9341231026492	3 Step	0.9m	0.42m	150Kg	7.0Kg	
OXDSF04	9341231026508	4 Step	1.2m	0.46m	150Kg	8.8Kg	
OXDSF06	9341231026515	6 Step	1.8m	0.54m	150Kg	11.0Kg	
OXDSF08	9341231026522	8 Step	2.4m	0.62m	150Kg	13.0Kg	
OXSEFT		Replacement feet (ea)					

150KG RATED FIBREGLASS PLATFORM LADDER

- Large anti-skid work platform with raised edges - keeps feet inside the platform for greater safety and comfort
- Braced platform and folds flat for storage
- Welded back leg bracing - much greater rigidity, safety, durability
- Optional bolt on handrail and gate - full surround safety
- Fibreglass - **Electrically safe and non-conductive**
- Replacement feet available



COMPLIES TO
AS/NZS
1892 : 2018



Code	Barcode	Description	Height*	Stance Width	Overall Stile Length	Load Rating	Weight
OXPLF02	9341231029868	2 Step	0.56m	0.54m	1.6m	150Kg	9.3Kg
OXPLF03	9341231026614	3 Step	0.85m	0.59m	1.9m	150Kg	10.7Kg
OXPLF04	9341231026621	4 Step	1.13m	0.63m	2.2m	150Kg	11.8Kg
OXPLF06	9341231026645	6 Step	1.69m	0.71m	2.8m	150Kg	16.5Kg
OXPLF08	9421901768232	8 Step	2.26m	0.80m	3.4m	150Kg	20.2Kg
OXPLFFEET		Replacement feet front (pair)					
OXPLFFEETR		Replacement feet rear/stair side (pair)					

* Heights show dimensions from floor to top of platform

FIBREGLASS LADDERS

TRADE SERIES FIBREGLASS TELESCOPIC ALL IN ONE LADDER

150KG RATED MULTI PURPOSE

EXTENDABLE LEGS - FOR EXTRA HEIGHT ADJUSTMENT & STAIR ACCESS

- **Electrically safe** Non conductive fibreglass stiles
- Easily seen hinge lock - it's obvious when it's engaged. Locks automatically
- Easily operated, heavy duty height lock - simple pull out and release
- All-in-One - four different settings for every application
- Rungs are attached to stiles with Titan tough rivets for superior strength and longevity



OXTLF04



COMPLIES TO
AS 1892 : 2018

Code	Barcode	Description	Length	Load Rating	Weight
OXTLF04	9421036061369	4 - 7 Step Telescopic	1.2m - 4.5m	150kg	20.5Kg
OXTLP	9421901768362	Clip-on Platform	N/A	N/A	N/A
OXTLFOU		Replacement feet outer L/R (pair)			
OXTLFIN		Replacement feet inner L/R (pair)			



150KG RATED FIBREGLASS DUAL PURPOSE LADDER

STEP LADDER / EXTENSION LADDER

- Hard-wearing feet - the fastest-wearing part of a ladder
- Internally braced side stay arms - much more stable
- Trapezoidal back steps - comfortable to use in the 'A' shape or folded out
- Stainless steel rivets with extra large heads for maximum durability
- Secure locking latch - guards against accidental dislodgement
- Fibreglass - **Electrically safe and non-conductive**
- Replacement feet available



COMPLIES TO
AS/NZS
1892 : 2018

Code	Barcode	Description	Length	Stance Width	Load Rating	Weight
OXDPF06	9341231026553	6 Step	1.8m - 3.2m	0.55m	150Kg	12.9Kg
OXDPF07	9341231026560	7 Step	2.1m - 3.9m	0.60m	150Kg	14.7Kg
OXDPF08	9341231026577	8 Step	2.4m - 4.5m	0.63m	150Kg	16.9Kg
OXSEFT		Replacement feet (ea)				

FIBREGLASS LADDERS



150KG RATED ADJUSTASTEP TELESCOPIC FIBREGLASS PLATFORM LADDER

FEATURES & BENEFITS

- **Electrically safe** Non conductive fibreglass stiles
- Height adjustable for working off a large safe platform at variable heights in seconds
- Set front and back stiles to varying heights for working on steps or uneven ground
- Handrail allows for 3 points of contact
- Large, hard-wearing rubber feet for stable grip
- Rated to 150kg for industrial applications
- One-piece, smooth operation – simply folds flat and locks
- Can be fitted with standard Adjustastep accessories – tool bucket, wheels and full surround handrail



4 STEP
1.2M PLATFORM
HEIGHT



5-STEP
1.4M PLATFORM
HEIGHT



6-STEP
1.7M PLATFORM
HEIGHT



7-STEP
2.0M PLATFORM
HEIGHT



COMPLIES TO
AS/NZS
1892 : 2018

Code	Barcode	Description	Height	Overall Stile Length	Load Rating	Weight
OXTPLF04-07	9421036060171	4-7 Step	1.2m - 2.0m	2.3m - 3.1m	150kg	30Kg
OXTPLFF		Replacement feet front (pair)				
OXTPLFB		Replacement feet rear (pair)				
OXPLTT		Optional Clip-on tool bucket				

150KG RATED FIBREGLASS EXTENSION LADDER

SINGLE ROPE OPERATION - LEAVES ONE HAND FREE TO SUPPORT THE LADDER WHILE IT IS ADJUSTED

- Side mounted rope - avoids tripping hazard
- Triple pulley - three times easier to lift
- Auto engaging height lock - ensuring your safety
- Heavy duty feet - resists wear
- 'D' Shape rungs - for comfortable standing
- Fibreglass - **Electrically safe and non-conductive**
- Replacement feet available

Code	Barcode	Description	Length	Load Rating	Weight
OXELF09	9341231026584	9 Step	2.8m - 4.7m	150Kg	13.1Kg
OXELF11	9341231026591	11 Step	3.5m - 6.0m	150Kg	15.6Kg
OXELF13	9341231026607	13 Step	4.1m - 7.2m	135Kg	18.1Kg
OXELFFEET		Replacement feet (pair)			



COMPLIES TO
AS/NZS
1892 : 2018



LADDER STAND OFF BRACKET

- Aluminium Ladder Stand Off Bracket to be used with Telescopic Ladders or Extension Ladders when in extended position
- Universal lock means the bracket can be used on a variety of ladder brands
- Keeps the ladder further from the surface the ladder is against to give more space for the user
- Useful for spanning over obstacles like downpipes, windows and other uneven obstacles
- Can be used against the fascia to protect the gutter from damage
- Grippy, heavy duty rubber feet



LADDERS

160KG RATED EASYSTEP - SAFETY STEP

FEATURES & BENEFITS

- 505mm x 505mm x 365mm(h)
- Huge 160kg Safe Working Load
- Indented steps on all four sides
- Improved grip tape for even greater stability
- Same reinforced underside for extra strength
- Available in orange and yellow colours



LOAD
RATING

Code	Description	Load Rating
EASTEP	EasyStep Orange	160Kg
EASTEPY	EasyStep Yellow	160Kg



WORK PLATFORMS, TRESTLES & PLANKS

Easy Access supplies a full range of work platforms, trestles and planks to support you working safely.

Our range includes aluminium and wooden planks and A frame trestles through to folding workhorses and aluminium platforms for quick and easy low level access.

Safe, efficient, *easy!*



WORK PLATFORMS, TRESTLES & PLANKS



225KG RATED QUICKLATCH WORKHORSE

FEATURES & BENEFITS

- Folds to an easily stored saw horse - takes 85% less room to store than a fixed leg version
- Simple locking legs for total safety
- Zinc coated for rust protection
- Half the weight of a wooden sawhorse
- Load capacity 225kg

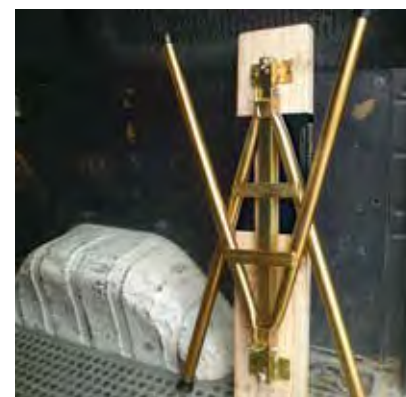

Code	Barcode	Description	Height	Length	Weight
WQLL	9421901464073	Quicklatch Workhorse	700mm	900mm	6.5Kg
WQLL/2	9421901464257	Quicklatch Workhorse Set of 2	700mm	900mm	13.0Kg

150KG RATED FOLDING ALUMINIUM WORK PLATFORM

- Lightweight and quick to assemble and move around
- Fold away legs for easy transport and storage
- Positive locking hinges with safety catch lock
- Anti-slip feet for added stability
- Perfect for low level decorating and standard height ceiling work
- Optional handrail fits either side for OXWP03W only
- Replacement feet available

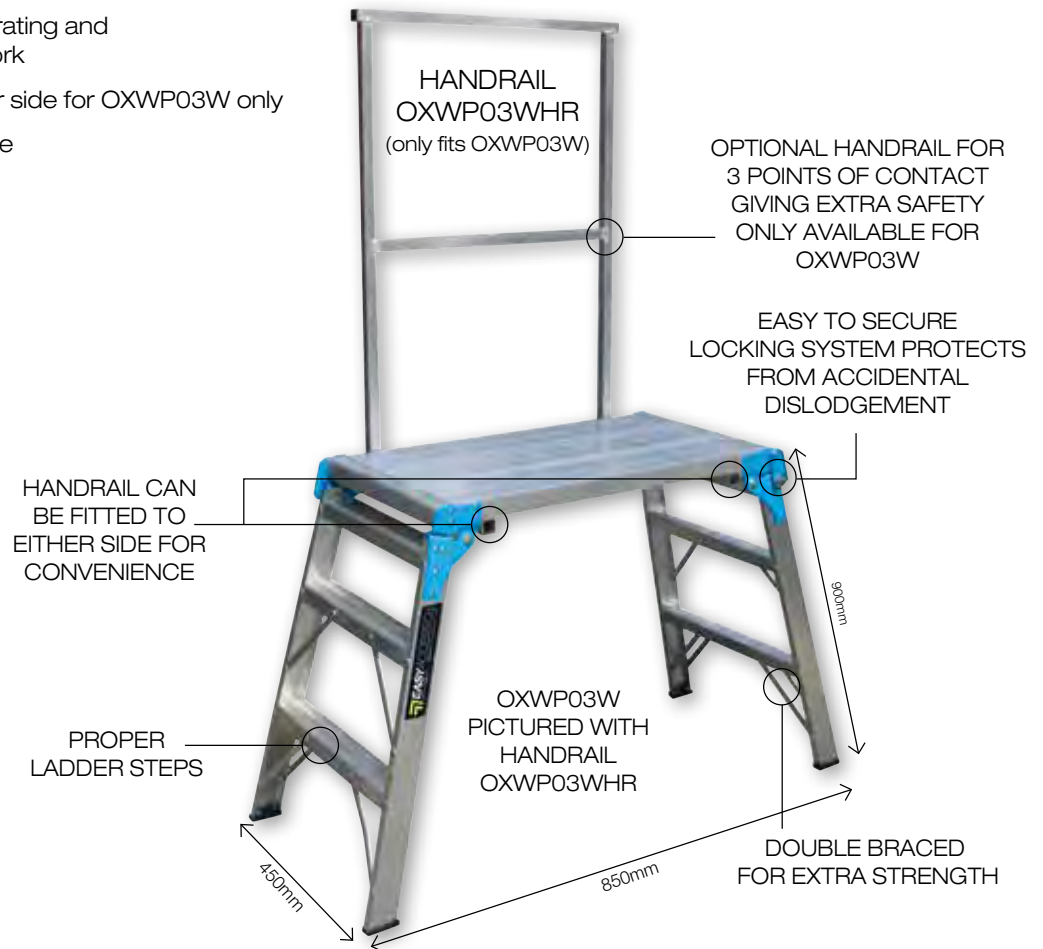

Code	Barcode	Description	Height	Length	Width	Load Rating	Weight
OXWP02	9421901768355	Folding Work Platform	500mm	850mm	300mm	150Kg	6.0Kg
OXWP03	9341231027147	Folding Work Platform	900mm	850mm	300mm	150Kg	7.0Kg
OXWP03W	9421901768799	Wide Folding Work Platform	900mm	850mm	450mm	150Kg	8.3Kg
OXWP03WHR	9421901768867	Handrail - for OXWP03W only	900mm	N/A	N/A	N/A	N/A
OXWPFEEET		Replacement feet (ea)					

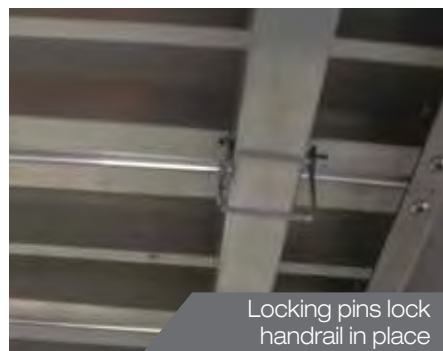

WORK PLATFORMS, TRESTLES & PLANKS





HEIGHT ADJUSTABLE WORK PLATFORMS

FEATURES & BENEFITS

- 6 height settings 600mm - 850mm
- Each leg independently adjustable for uneven ground
- Lightweight and folds flat for easy store
- Available with 1250mm and 850mm long platform
- Optional guardrail available
- 450mm wide platforms for safety and efficiency
- Replacement feet available
- Independently adjustable legs through 6 height settings



HANDRAIL
OXWP03WHR

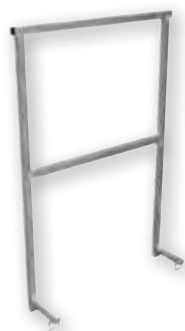

Code	Description	Height	Length	Width	Load Rating	Weight
ADJWP120	Folding 3 step Work platform adjustable legs	0.6m - 0.85m	1250mm	450mm	150Kg	11.8Kg
ADJWP085	Folding 3 step Work platform adjustable legs	0.6m - 0.85m	850mm	450mm	150Kg	10.8Kg
ADJWPFEET	Replacement feet (ea)					

WORK PLATFORMS, TRESTLES & PLANKS

150KG RATED ALUMINIUM "A" FRAME TRESTLES

FEATURES & BENEFITS

- Much lighter and more user friendly than steel
- Full width to take two planks meeting safety standards
- Adjustable foot option for uneven ground
- Fully welded rung and box section stiles give great strength and durability

Code	Barcode	Description	Width	Load Rating	Weight
AFT120	9341231008030	1.2m Aluminium Trestle	485mm	150Kg	7.5Kg
AFT180	9421901086879	1.8m Aluminium Trestle	485mm	150Kg	10.5Kg
AFT240	9421901086886	2.4m Aluminium Trestle	485mm	150Kg	14.5Kg
AFT300	9421901086893	3.0m Aluminium Trestle	485mm	150Kg	18.0Kg
AFT360	9341231008047	3.6m Aluminium Trestle	485mm	150Kg	22.0Kg
AFT420	9341231008054	4.2m Aluminium Trestle	485mm	150Kg	28.5Kg
AFT480	9341231008061	4.8m Aluminium Trestle	485mm	150Kg	32.0Kg
ADJ04	9341231008078	Adjustable feet (x4) - Optional			



COMPLIES TO
AS/NZS
1892 : 2018



TELESCOPIC ALUMINIUM PLANK

FEATURES & BENEFITS

Heavy duty expandable platform

- Simply extend and lock at desired length
- Compact for easy handling and transportation
- Lightweight and robust aluminium construction
- Slip resistant surface for safety
- Rubber end caps prevent damage
- Smooth sliding action for effortless adjustment
- Help turn telescopic ladders into a versatile work platform



COMPLIES TO
AS 6001 : 1999



Code	Barcode	Description	Length	Width	Load Rating
OX-TP40	9341231008252	Telescopic Plank	2.23m - 4.0m	255mm	150Kg



LOCKING MECHANISM TO FIX PLANK AT DESIRED LENGTH

STABULL - THE FASTEST WORK PLATFORM ON THE PLANET!

FEATURES & BENEFITS

- One piece, height adjustable sets up in seconds
- Large work area for industrial trade use
- Non-slip perforated platform deck guaranteed and proven safety
- Folds down flat for easy transport & storage
- Simply select the height by sliding in the pin, walk up the integral ladder and start work
- Optional full surround handrail - also folds flat for storage and transport
- Replacement feet available

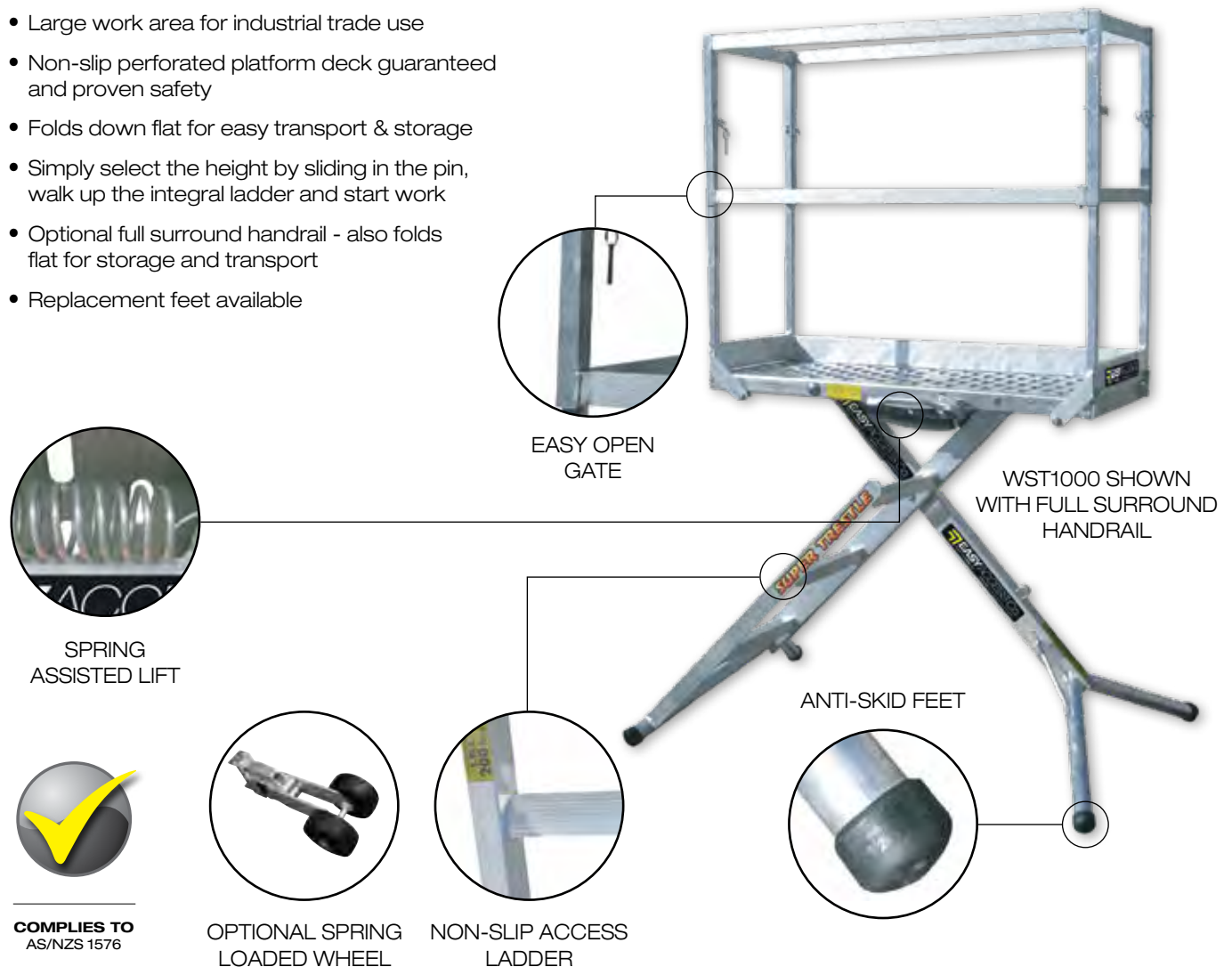

WORK PLATFORMS, TRESTLES & PLANKS

COMPLIES TO
AS/NZS 1576

OPTIONAL SPRING
LOADED WHEEL

NON-SLIP ACCESS
LADDER

Code	Description	Deck Size	Height	Load Rating	Weight
WST1000	Wide Stabull Platform Max Height 1000mm	450mm x 1200mm	400mm - 1000mm*	225Kg	23.0Kg
WST1300	Wide Stabull Platform Max Height 1300mm	450mm x 1600mm	600mm - 1300mm*	225Kg	25.0Kg
WST1700	Wide Stabull Platform Max Height 1700mm	450mm x 1600mm	700mm - 1700mm*	225Kg	28.0Kg
45WTP	Wide 450mm X 2.4m Long Treadplank	450mm x 2400mm		225Kg	
45LTP	Wide 450mm X 3.0m Long Treadplank	450mm x 3000mm		225Kg	
PHR24	Handrail for 2.4 Treadplank				
PHR30	Handrail for 3.0 Treadplank				
WSTFSH10	WST Full Surround Handrail for WST1000				
WSTFSH17	WST Full Surround Handrail WST1300/1700				
STW	Stabull Spring Loaded Wheel				
STFEETCAP	Replacement feet (ea)				

* Approximate mm

INDUSTRIAL PLATFORMS

Businesses that are looking to streamline operations and improve operator safety whilst managing costs need to see the Easy Access range. Height access products to make warehouses and distribution centres safe, efficient and productive.

Order pickers and platforms for use in warehouses, portable stairs for logistics operations, and heavy duty mobile platforms for industrial use.



*Products to
streamline your
operations whilst
improving operator
safety...
GUARANTEED!*

FOLDING ORDER PICKER - ALUMINIUM WHEELED CHASSIS

- Strong and lightweight; high tensile aluminium construction
- Fast; no assembly required and the ladder folds flat to assist with storage and handling
- Sturdy; fully welded joints, no rivets to work loose over time
- Smart; the wheel carriage is operated from the front and folds quickly away once the ladder is in position
- Durable; corrosion resistant aluminium
- Reliable; 10 year guarantee



**MADE IN
NEW ZEALAND
ISO9001**



**COMPLIES TO
AS/NZS
1892 : 2018**



**WARTHOG
WELDED
LADDERS**

Code	Description	Platform Height	Base Width	Base Length	Load Rating
WHOP05WC	5 Step with Wheeled Carriage	1410mm	926mm	1350mm	150Kg
WHOP06WC	6 Step with Wheeled Carriage	1692mm	926mm	1500mm	150Kg
WHOP07WC	7 Step with Wheeled Carriage	1974mm	926mm	1650mm	150Kg
WHOP08WC	8 Step with Wheeled Carriage	2256mm	926mm	1800mm	150Kg
WHOP09WC	9 Step with Wheeled Carriage	2538mm	1092mm	1950mm	150Kg
WHOP10WC	10 Step with Wheeled Carriage	2820mm	1092mm	2100mm	150Kg
WHOP11WC	11 Step with Wheeled Carriage	3100mm	1092mm	2250mm	150Kg
WHOP12WC	12 Step with Wheeled Carriage	3383mm	1092mm	2400mm	150Kg

QUICK AND EASY SET UP - NO HASSLE



STEP 1
OPEN LATCH



STEP 2
UNFOLD



STEP 3
PULL UNTIL OPEN
& FULLY SECURE



STEP 4
RAISE TO DISENGAGE
WHEELS AND PUSH
DOWN LEVER



STEP 5
CLIMB & OPEN
SECURITY RAIL



STEP 6
EASY WITHOUT
COMPROMISING
ON SAFETY

FOLDING ORDER PICKER - ALUMINIUM SPRING WHEELED

This ladder incorporates the same design and specifications as the wheeled chassis version with the following alterations:

- Spring wheels for easy manoeuvrability
- Low cost & simple to use
- Built tough for industrial use



LARGE 600 X 600MM
WORKING AREA

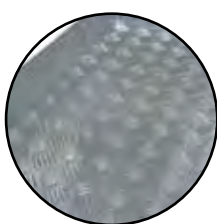

STRONG BOX
SECTION SAFETY RAIL

LOCKING PLATFORM
FOR SAFE USE



LARGE SAFE
STAIR TREADS

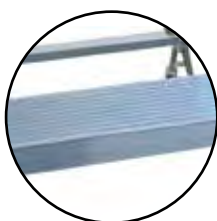

SPRING WHEELS
FOR EASY
MANOEUVRABILITY



RUBBER ANTI-SLIP FEET

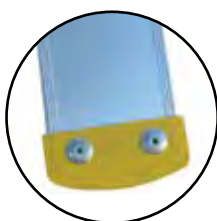

WARTHOG
WELDED
LADDERS

Code	Description	Platform Height	Base Width	Base Length	Load Rating
WHOP03SW	3 Step with Spring Wheels	846mm	926mm	1050mm	150Kg
WHOP04SW	4 Step with Spring Wheels	1128mm	926mm	1200mm	150Kg
WHOP05SW	5 Step with Spring Wheels	1410mm	926mm	1350mm	150Kg
WHOP06SW	6 Step with Spring Wheels	1692mm	926mm	1500mm	150Kg
WHOP07SW	7 Step with Spring Wheels	1974mm	926mm	1650mm	150Kg



COMPLIES TO
AS/NZS
1892 : 2018



HEAVY DUTY MAINTENANCE PLATFORM - ALUMINIUM

- Full guardrailing and gates for safe fast access
- Built tough with 6261 T6 grade aluminium
- Perforated & swaged deck for superior traction in wet & greasy conditions
- Large work surface and 225kg SWL for all maintenance requirements
- 200mm solid rubber wheels allow for easy relocation on all terrains

Code	Platform Height	Platform Size	Steps
WHDP02	565mm	800 x 800mm	2 Step
WHDP03	850mm	800 x 800mm	3 Step
WHDP04	1130mm	800 x 800mm	4 Step
WHDP05	1400mm	800 x 800mm	5 Step
WHDP06	1700mm	800 x 800mm	6 Step
WHDP07	1970mm	1000 x 1000mm	7 Step
WHDP08	2250mm	1000 x 1000mm	8 Step
WHDP09	2540mm	1000 x 1000mm	9 Step
WHDP10	2828mm	1000 x 1000mm	10 Step
WHDP11	3100mm	1000 x 1000mm	11 Step



**LOAD
RATING**



**COMPLIES TO
AS/NZS
1657: 2018**



**MADE IN
NEW ZEALAND
ISO9001**



HEAVY DUTY MAINTENANCE PLATFORM - ALUMINIUM



CANTILEVER MAINTENANCE PLATFORM - ALUMINIUM

- An essential tool for all machinery service workshops
- Allows you to get right into and up against your work area without reaching out from the platform
- Built tough, non-slip perforated deck and aluminium frame



CLEARANCE FOR CANTILEVER PLATFORMS

Code	Platform Height	Platform Size	Steps
WHDPC02	565mm	800 x 1800mm	2 Step
WHDPC03	850mm	800 x 1800mm	3 Step
WHDPC04	1150mm	800 x 1800mm	4 Step
WHDPC05	1400mm	800 x 1800mm	5 Step
WHDPC06	1700mm	800 x 1800mm	6 Step
WHDPC07	1970mm	1000 x 2000mm	7 Step
WHDPC08	2250mm	1000 x 2000mm	8 Step
WHDPC09	2540mm	1000 x 2000mm	9 Step
WHDPC10	2828mm	1000 x 2000mm	10 Step
WHDPC11	3100mm	1000 x 2000mm	11 Step
CA200	200mm Swivel plate caster, fully locking (spare part)		



LIFT UP REAR SAFETY BAR

FRONT SELF LOCKING SAFETY SWING GATE



SWL & SERIAL NUMBERED PLATE



INSERT COUNTER WEIGHT

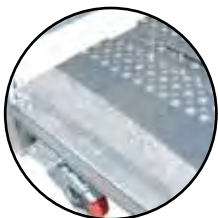

LARGE HEAVY DUTY 200MM, BRAKED CASTERS



LOAD RATING



COMPLIES TO AS/NZS 1657: 2018

ROOF EDGE / PLATFORM ACCESS SYSTEMS

EasyRail roof edge protection offers a bolt-free cantilever bracket for securing the system to the soffit for safe and compliant access to roofs. Add EasyDeck platforms to the posts for access to the building walls creating a convenient, easy-to-install modular scaffold and edge protection system.

**USING EASY
ACCESS MULTI
MOBILE SCAFFOLDS? -
SEE SAFEROOF ON
PAGE 24 FOR ADDING
COMPONENTS TO
CREATE ROOF EDGE
PROTECTION**

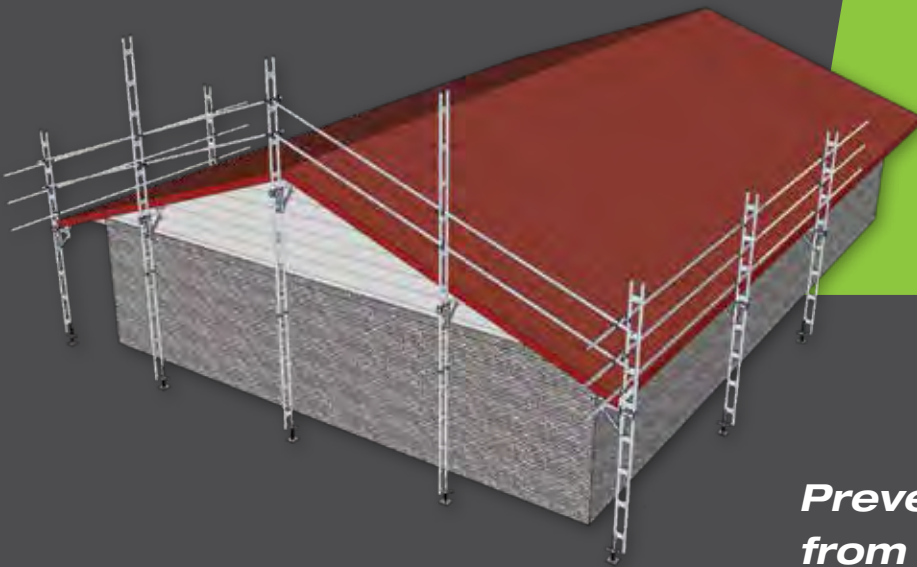

**Preventing falls
from height
the *EASY WAY!***

EDGE PROTECTION

SAFETY GUIDELINES

EDGE PROTECTION REQUIRED

Edge protection must be provided on all work surfaces where a person can fall 2mtrs or more.

BOLT-FREE EDGE PROTECTION

Easy Access EasyRail Edge protection uses a bolt-free cantilever base or under-soffit bracket system - no unsightly scars!

MODULAR AND EASILY MOVED

Easy Access Edge Protection is modular - surround a full house, or move a small section around as required.

GUARDRAILS

Three guardrails are required for roofs with an angle of slope of 10deg – 35deg – only a guardrail and midrail are required for gable ends.

GUARDRAIL POSITIONING

The lowest guardrail should be positioned no more than 150mm above gutter height, and rails above no more than 500mm apart.

EDGE PROTECTION COMPLIANCE

Temporary roof edge protection systems on roofs with an angle of slope up to 35deg must comply with the requirements of AS/NZS 4994.1:2009.

PLATFORM EDGE PROTECTION

Add EasyDeck components to provide platform access to building fascia when using EasyRail edge protection.

DISTANCE TO WORK

The platform should be no more than 300mm from the working face.

MADE IN NZ

EasyRail Roof Edge Protection, and EasyDeck Platform access systems are made in NZ to ASNZS 4994 : 2009 standards.



NB. Worksite requirements may vary, and may be more stringent than the legal requirement.

ROOF EDGE / PLATFORM ACCESS SYSTEMS

EASYRAIL

THE FASTEST ROOF EDGE PROTECTION SYSTEM TO INSTALL

FEATURES & BENEFITS

- EasyRail roof edge protection is available in 4 standard post heights, 1m, 2m, 3m and 4m these can also be joined using the EasyRail joining spigot
- For installation, the cantilever bracket simply slides up the posts and is tightened under the eaves
- Using couplers and aluminium tube, base, mid and top rails can be installed in minutes
- EasyRail is the ultimate safe solution for any low level roof edge protection application
- Platforms maybe installed at any height on the EasyRail posts for access to building fascia



COMPLIES TO
AS/NZS
4994 : 2009



Ideal for low level roofing applications



SWIVEL COUPLER



CANTILEVER BRACKET



EASYRAIL POST

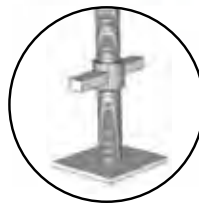
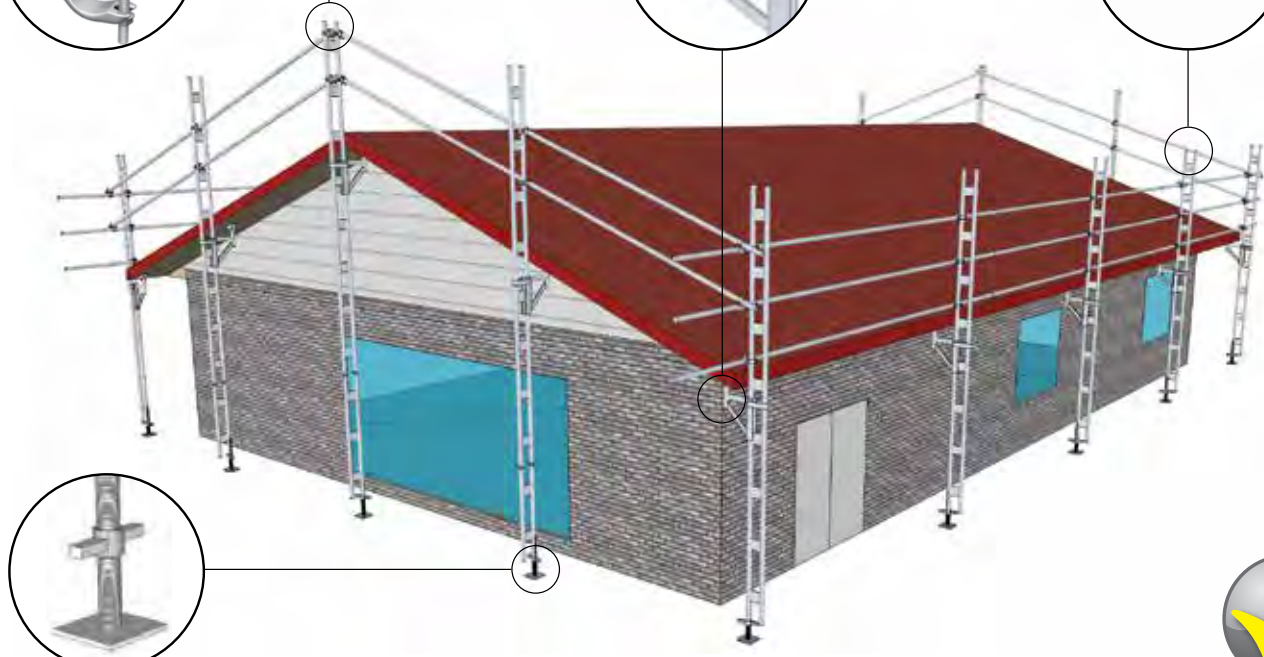
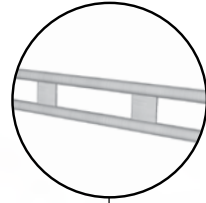

SCREW JACK



COMPLIES TO
AS/NZS
4994 : 2009

STEP UP GUIDE AND QUICK INSTALLATION TIPS



STEP 1

Measure the height to the underside of eaves and place the cantilever bracket at correct height on the easyrail post.



STEP 2

Place base of post over a screw jack and lean against the roof edge of the building. Repeat and space no more than 4m to desired length.



STEP 3

Adjust the screw jack until the cantilever bracket is held firm under the eaves. Ensure the post is vertical and the cantilever bracket is under a solid member if required, fix bracket to underside of eaves.

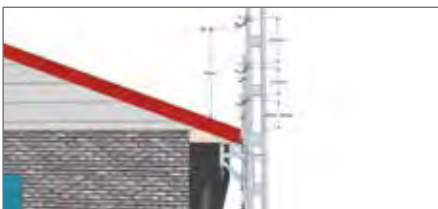

STEP 4

Using a ladder, place rail coupler at a point 200mm above the roof line. Fix 2 more couplers at 500mm and 1000mm above this same point. Ensure the coupler "tongues" are positioned facing upwards to hold handrail.

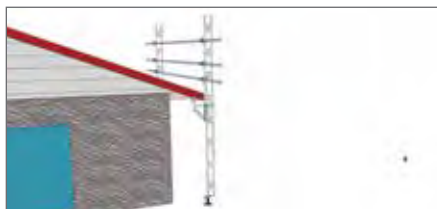

STEP 5

Using a ladder, place the aluminium tube rails in position, then tighten each coupler.

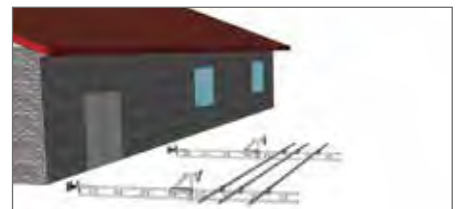

QUICK INSTALL TIP:

If 2 people are available then the horizontal rails can be fitted to the posts while on the ground. Lift the complete assembly into place and tighten screw jacks under the eaves.

ROOF EDGE / PLATFORM ACCESS SYSTEMS



EASYRAIL ALUMINIUM EDGE PROTECTION PACKS

HALF GABLE END & 6.0M OF STRAIGHT EDGE PROTECTION

PACK A	Description	Batch Qty
AER300.400	4.0m EasyRail Truss, Roof Post	4
AER300.200	2.0m EasyRail Truss, Roof Post	2
AER350.600	EasyRail Tube 6.0m length	5
AER610.300	0.30m EasyRail Cantilever Bracket	4
ER500.060	0.60m Base Jack - Adjustable	4
IN48	EasyRail Internal Joining Spigot	4
FX48	EasyRail Fixed Double Coupler	9
SW48	EasyRail Swivel Coupler	4

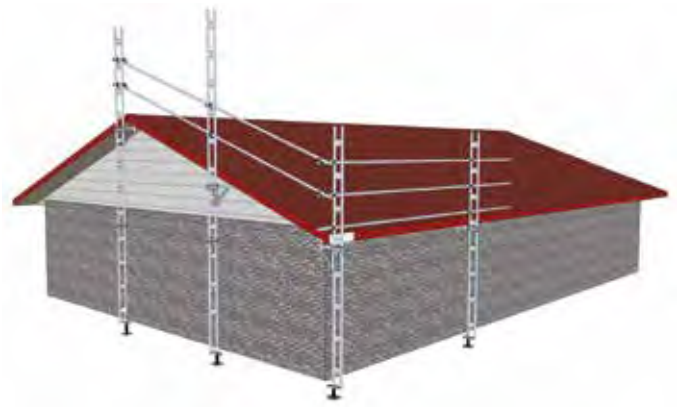

FULL GABLE END & 12.0M OF STRAIGHT EDGE PROTECTION

PACK B	Description	Batch Qty
AER300.400	4.0m EasyRail Truss, Roof Post	8
AER300.200	2.0m EasyRail Truss, Roof Post	1
AER300.100	1.0m EasyRail Truss, Roof Post	2
AER350.600	EasyRail Tube 6.0m length	10
AER610.300	0.30m EasyRail Cantilever Bracket	8
ER500.060	0.60m Base Jack - Adjustable	8
IN48	EasyRail Internal Joining Spigot	6
FX48	EasyRail Fixed Double Coupler	15
SW48	EasyRail Swivel Coupler	12

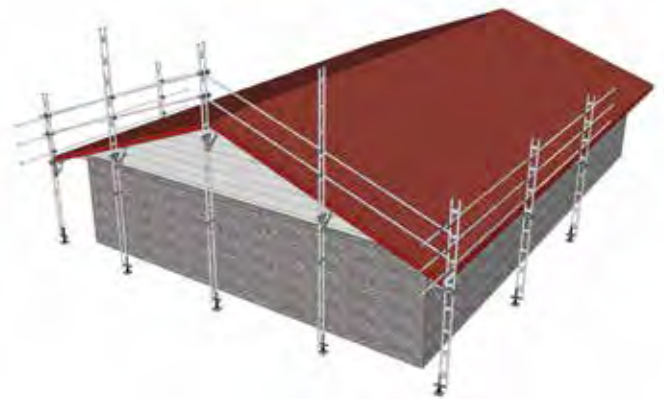

STRAIGHT EDGE PROTECTION 6.0M

PACK C	Description	Batch Qty
AER300.400	4.0m EasyRail Truss, Roof Post	2
AER350.600	EasyRail Tube 6.0m length	3
AER610.300	0.30m EasyRail Cantilever Bracket	2
ER500.060	0.60m Base Jack - Adjustable	2
FX48	EasyRail Fixed Double Coupler	6



GABLE END ONLY 12.0M

PACK D	Description	Batch Qty
AER300.400	4.0m EasyRail Truss, Roof Post	5
AER300.200	2.0m EasyRail Truss, Roof Post	1
AER300.100	1.0m EasyRail Truss, Roof Post	2
AER350.600	EasyRail Tube 6.0m length	4
AER610.300	0.30m EasyRail Cantilever Bracket	5
ER500.060	0.60m Base Jack - Adjustable	5
IN48	EasyRail Internal Joining Spigot	6
SW48	EasyRail Swivel Coupler	12

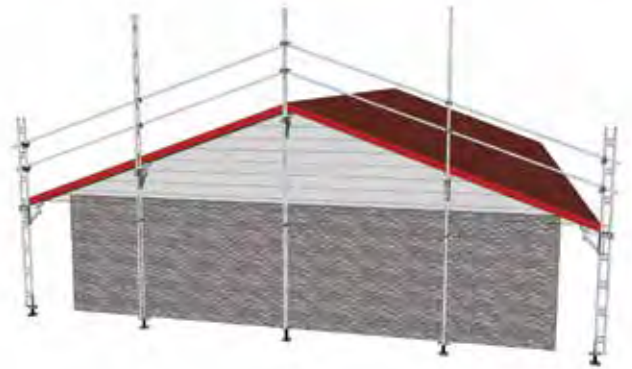

FULL HOUSE LOT 52 METRES

PACK E	Description	Batch Qty
AER300.400	4.0m EasyRail Truss, Roof Post	16
AER300.200	2.0m EasyRail Truss, Roof Post	6
AER350.600	EasyRail Tube 6.0m length	26
AER610.300	0.30m EasyRail Cantilever Bracket	16
ER500.060	0.60m Base Jack - Adjustable	16
IN48	EasyRail Internal Joining Spigot	24
FX48	EasyRail Fixed Double Coupler	38
SW48	EasyRail Swivel Coupler	16

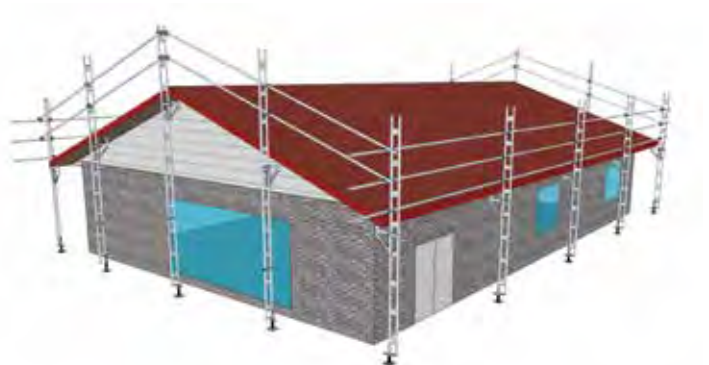

ROOF EDGE / PLATFORM ACCESS SYSTEMS

EASYDECK

THE EASYDECK ADVANTAGE

FEATURES & BENEFITS

- A high strength, lightweight welded aluminium structure
 - Protect from roof falls while working on the soffit and wall of the building
 - This is a multi use system combination
 - System is free standing, does not require any fixing to the building
 - Fast, two person set up, it reduces downtime on the job saving time and money
 - Unique combination of the easy rail edge protection system, Easy Access prefabricated platforms and cantilever support brackets
 - The system incorporates many standard Easy Access scaffold components including guardrails and platforms. You can save money by adding to the scaffold components you already have
- Certified aluminium or wooden planks can be used to create a work platform
 - Height adjustable screw jacks allow for uneven ground
 - The base frame can be located on the top of standard Easy Access H-Frames to enable quick and safe access and edge protection on two story homes
 - Platform height is totally adjustable along the length of the easy rail post



**LOAD
RATING**



**COMPLIES TO
AS/NZS 1576**

EASY INSTALL

1



2

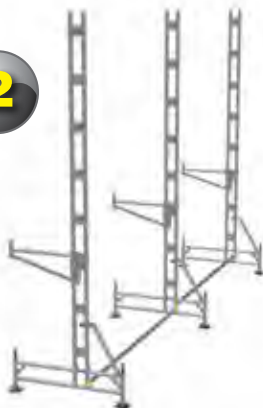

3



4



STANDARD DIMENSIONAL REQUIREMENTS

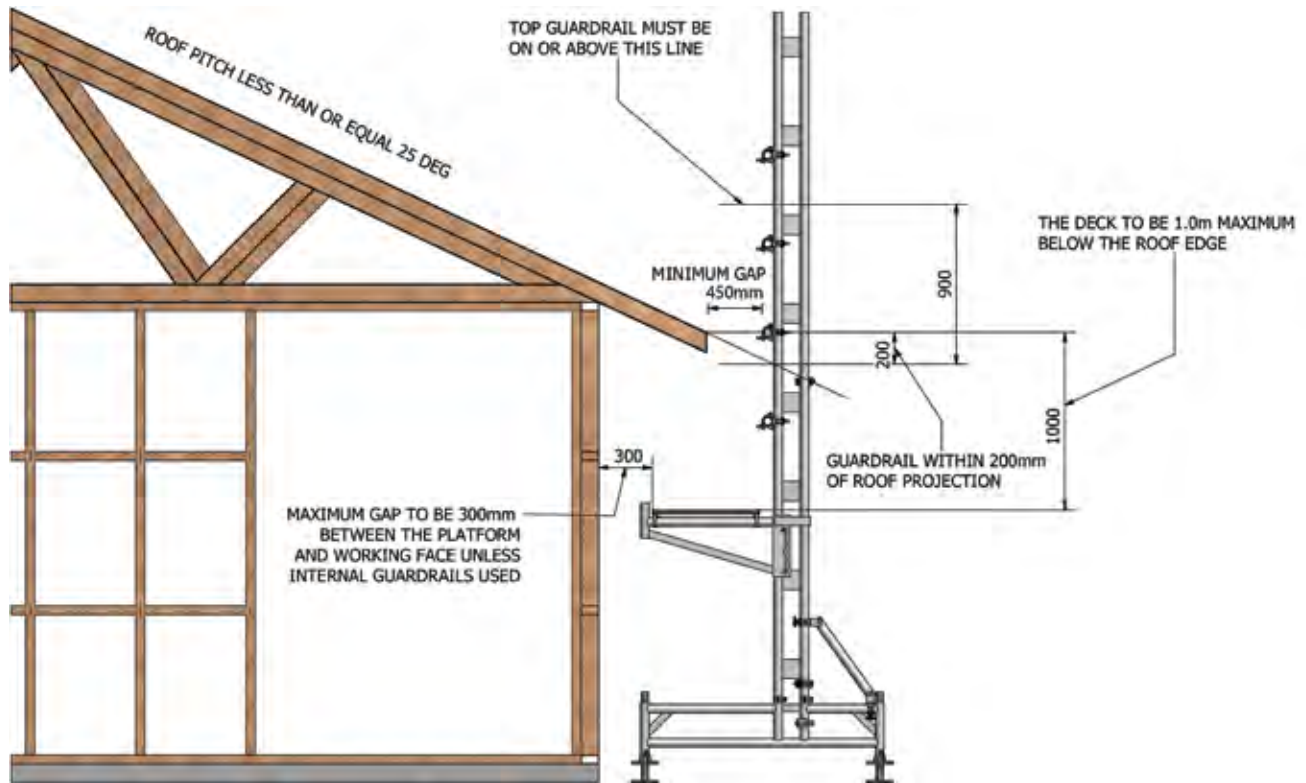

EASYDECK PACKS

PACK F - 3M STARTER BAY

PACK F	DESCRIPTION	BATCH QTY
IN48	Easyrail Internal Joining Spigot	4
BPA605	Adjust. Base Plate	4
AER FRAME	Alloy Easyrail Frame	2
AER610.650	0.65m Alloy Easyrail Cantilever Bracket	2
PFS440	3.0m Standard Platform	1
AER300.400	4.0m Alloy Easyrail Truss, Roof Post	2
AER100.300	3.0m Alloy Easyrail Diagonal Brace	1
GRB430	3.0m Grasper Guardrail	1
FX48	Easyrail Fixed Double Coupler	8

- Toe boards are required if the platform is over 2m high
- Timber scaffold planks can be used to create a toe board
- Additional Ladder Access Gates are available to close in corners



PACK G - 6M HANDRAIL PACK

PACK G	DESCRIPTION	BATCH QTY
AER350.600	Alloy Easyrail Tube	4
IN48	Easyrail Internal Joining Spigot	4
FX48	Easyrail Fixed Double Coupler	4

- Attach to easy rail roof post with fixed double castors
- Join together with expanding spigots

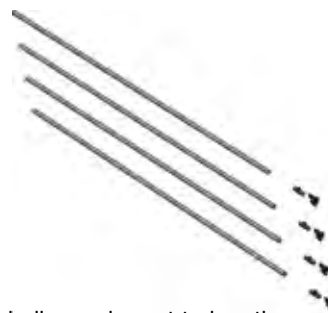

NOTE : Handrails can be cut to length

PACK H - 3M ADD ON BAY

PACK H	DESCRIPTION	BATCH QTY
GRB430	3.0m Grasper Guardrail	1
PFS440	3.0m Standard Platform	1
AER300.400	4.0m Alloy Easyrail Truss, Roof Post	1
IN48	Easyrail Internal Joining Spigot	2
BPA605	Adjust. Base Plate	2
AER FRAME	Alloy Easyrail Frame	1
FX48	Easyrail Fixed Double Coupler	4
AER610.650	0.65m Alloy Easyrail Cantilever Bracket	1

- Outriggers must be used every 3 bays minimum
- Diagonals must be used every 4 bays minimum
- 4.0m x 6.0m guardrails need to be added every second bay



REFER TO PAGES 107 - 108 EASY SYSTEM COMPONENTS LIST

PACK I - 2.4M ADD ON BAY

PACK I	DESCRIPTION	Batch Qty
GRB420	2.4m Grasper Guardrail	1
PFS435	2.4m Standard Platform	1
AER300.400	4.0m Alloy Easyrail Truss, Roof Post	1
IN48	Easyrail Internal Joining Spigot	2
BPA605	Adjust. Base Plate	2
AER FRAME	Alloy Easyrail Frame	1
FX48	Easyrail Fixed Double Coupler	4
AER610.650	0.65m Alloy Easyrail Cantilever Bracket	1

- Alternative to Pack H



PACK J - 21M STRAIGHT PLATFORM EDGE PROTECTION

PACK J	DESCRIPTION	Batch Qty
IN48	Easyrail Internal Joining Spigot	28
BPA605	Adjust. Base Plate	16
AER FRAME	Alloy Easyrail Frame	8
AER610.650	0.65m Alloy Easyrail Cantilever Bracket	8
PFS440	3.0m Standard Platform	7
AER300.400	4.0m Alloy Easyrail Truss, Roof Post	8
AER100.300	3.0m Alloy Easyrail Diagonal Brace	2
AER350.600	Alloy Easyrail Tube	14
GRB430	3.0m Grasper Guardrail	7
FX48	Easyrail Fixed Double Coupler	32
ORG705	Outrigger	2

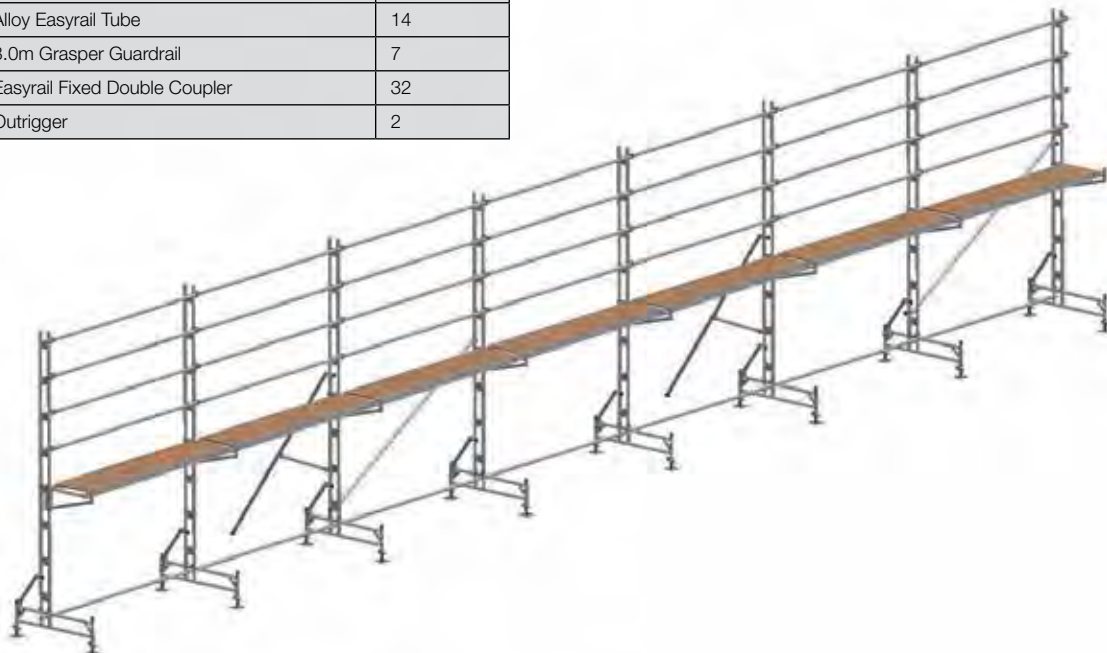

REFER TO PAGES 107 - 108 EASY SYSTEM COMPONENTS LIST

EASYDECK PACKS

PACK K - 70M HOUSELOT

PACK K	DESCRIPTION	BATCH QTY
GRB420	2.4m Grasper Guardrail	2
GRB430	3.0m Grasper Guardrail	23
GRL300	3.0m Reinforced Grasper Ledger	4
PFS410	1.0m Standard Platform	1
PFS415	1.5m Standard Platform	1
PFS435	2.4m Standard Platform	2
PFS440	3.0m Standard Platform	22
AER300.200	2.0m Alloy Easyrail Truss, Roof Post	2
AER300.400	4.0m Alloy Easyrail Truss, Roof Post	29
IN48	Easyrail Internal Joining Spigot	90
BPA605	Adjust. Base Plate	62
AER FRAME	Alloy Easyrail Frame	31
FX48	Easyrail Fixed Double Coupler	144
AER610.650	0.65m Alloy Easyrail Cantilever Bracket	31
AER100.300	3.0m Alloy Easyrail Diagonal Brace	9
LAG0.5	Ladder Access Gate	2
AER350.600	Alloy Easyrail Tube	330
ORG705	Outrigger	4





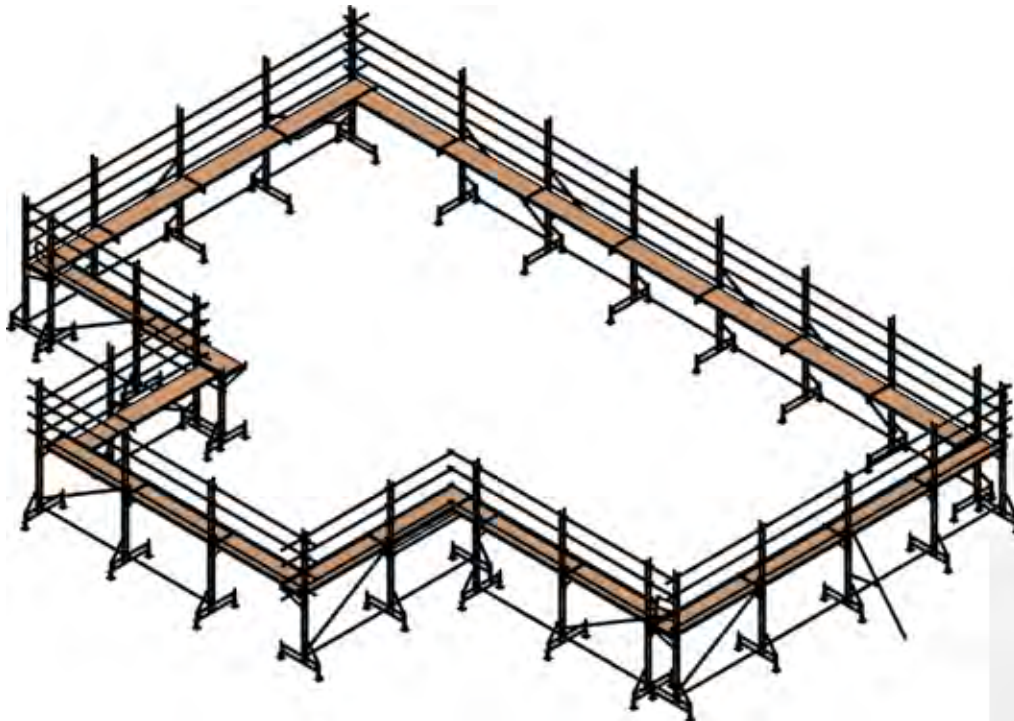



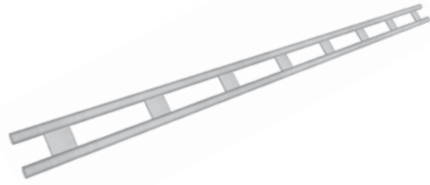

- A comprehensive pack of equipment that includes multiple internal and external corner kits as well as two gated access points.

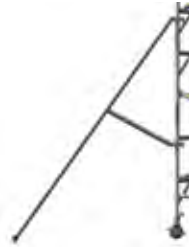









REFER TO PAGES 107 - 108 EASY SYSTEM COMPONENTS LIST

EASY SYSTEM COMPONENTS

PLATFORM SUPPORT BRACKET		EASYRAIL ROOF POST	
<ul style="list-style-type: none"> Attaches to the roof post and supports the work platform. Height adjustable. 		<ul style="list-style-type: none"> Strong and lightweight. Can be joined vertically. Custom length available. 	
			
AER610.650	0.65m Cantilever Bracket	AER300.200	2.0m
		AER300.300	3.0m
		AER300.400	4.0m
BASE FRAME		OUTRIGGERS	
<ul style="list-style-type: none"> Supports the roof post using two internal joining spigots and a brace. 		<ul style="list-style-type: none"> Connect to roof posts and provide extra stability to the system. Must be used every 3 bays minimum. 	
			
AER FRAME	1.37m	ORG705	Outrigger
SWIVEL COUPLER		90° FIXED COUPLERS	
<ul style="list-style-type: none"> Used for attaching guard rails to the posts that are not 90 degrees to it. E.g. gable ends. 		<ul style="list-style-type: none"> Used for attaching horizontal rails to the posts. 	
			
SW48	Swivel Coupler	FX48	Fixed Coupler
ALUMINIUM EASYRAIL TUBE	SCREW JACKS	INTERNAL JOINING SPIGOT	
<ul style="list-style-type: none"> Can be cut to specific lengths. Used for toerail, midrail and handrails. Up to 4m span between posts. 	<ul style="list-style-type: none"> Inserted into the sleeves on Base frames to support the system and compensate for uneven ground. 	<ul style="list-style-type: none"> Used for joining tubes together end to end by expanding inside them. 	
			
ER350.600	6.0m	ER500.060	0.60m
		IN48	Internal Joiner

ROOF EDGE / PLATFORM ACCESS SYSTEMS

EASY SYSTEM COMPONENTS

CANTILEVER BRACKET			DIAGONAL BRACE	
<ul style="list-style-type: none"> Fits under eaves. Includes swivel plate. 			<ul style="list-style-type: none"> Must be used every 4 bays minimum. 	
CODE	DESCRIPTION	LENGTH	CODE	DESCRIPTION
AER610.300	Cantilever Bracket	0.30m	AER100.240	2.4m
			AER100.300	3.0m
STANDARD PLATFORM			SNAPLOCK LEDGER	
<ul style="list-style-type: none"> Hook over the platform support bracket. 			<ul style="list-style-type: none"> Used to connect the base frames together longitudinally. Can also be used as a guardrail. 	
CODE	DESCRIPTION		CODE	DESCRIPTION
PFS410	1.0m		GRB410	1.0m
PFS415	1.5m		GRB415	1.5m
PFS435	2.4m		GRB420	2.4m
PFS440	3.0m		GRB430	3.0m
PROSCAF SWING GATE			REINFORCED GRASPER LEDGER	
<ul style="list-style-type: none"> Used where the ladder access is outside the Platform Easyrail system. 			<ul style="list-style-type: none"> Used to span across corners. 	
CODE	DESCRIPTION		CODE	DESCRIPTION
LAG0.5	Ladder Gate		GRL300	3.0m
HATCHED PLATFORM			HANDRAIL POST	
<ul style="list-style-type: none"> Ladder protrudes through the hatch lid for use when the ladder access is within the Platform Easyrail system.  <p>ALSO AVAILABLE IN CUSTOM SIZES TO ORDER</p>			<ul style="list-style-type: none"> Attaches to the inner sleeve on the platform support bracket where the platform edge is greater than 225mm away from the wall. 	
CODE	DESCRIPTION		CODE	DESCRIPTION
PFA465	2.4m		MHP	Handrail Post
PFA470	3.0m			



SAFE AND SIMPLE ACCESS FOR A PLATFORM HEIGHT OF 1-4 METRES

FEATURES & BENEFITS

- 300mm of baseplate adjustment makes it useable on rough terrain
- Minimal componentry makes it quick and easy to assemble
- 600mm wide platforms are rated to 225kg allowing access for 2 people at once
- Can be used with 3 standard scaffold planks
- Can be used with standard Easy Access 800mm wide H frames for extra height
- 2.4m and 3m bay lengths are available
- Bridging ledgers allow the system to go around a house
- Safety access gate available
- Additional midrails are required on platforms above 1m in height

**UTILISE
COMPONENTS
FROM EXISTING
EASY ACCESS
EQUIPMENT**



Note: Some sites require midrails on platforms regardless of height.



COMPLIES TO
AS/NZS
1576 : 2015



**LOAD
RATING**

ROOF EDGE / PLATFORM ACCESS SYSTEMS

EASYREACH



ADD EASY ACCESS
H-FRAMES FOR PLATFORM
HEIGHT UP TO 4M

**FAST
SET-UP TIMES
4 BAYS IN 10
MINUTES!**

CORNER CONFIGURATION
WITH SAFETY ACCESS GATE



EASYREACH PACKS

STARTER PACK

LLP01 - 2.4	DESCRIPTION	BATCH QTY
LLF800	800 Multi Cross L Frame	2
CBM110	Multi Frame Cross Brace 2.4m	1
PFS435	Standard Platform 2.4m	1
GRB420	Snaplock Guardrail 2.4m	1
BPA605	Adj Base Plate	4
LARG0.5	Ladder Access Gate	1

LLP02 - 3M	DESCRIPTION	BATCH QTY
LLF800	800 Multi Cross L Frame	2
CBM310	Multi Frame Cross Brace 3m	1
PFS440	Standard Platform 3m	1
GRB420	Snaplock Guardrail 2.4m	1
BPA605	Adj Base Plate	4
LARG0.5	Ladder Access Gate	1

- Toeboards are required if the platform is over 2m high
- Timber scaffold planks can be used to create a toe board
- Additional Ladder Access Gates are available to close in corners
- Midrails are required on cross braced bays with platforms above 1m high



ADD ON BAYS

LLP03 - 2.4	DESCRIPTION	BATCH QTY
LLF800	800 Multi Cross L Frame	1
CBM110	Multi Frame cross brace 2.4m	1
PFS435	Standard Platform 2.4m	1
GRB420	Snaplock Guardrail 2.4m	1
BPA 605	Adj Base Plate	2

LLP04 - 3M	DESCRIPTION	BATCH QTY
LLF800	800 Multi Cross L Frame	1
CBM310	Multi Frame Cross Brace 3m	1
PFS440	Standard Platform 3m	1
GRB430	Snaplock Guardrail 3m	1
BPA605	Adj Base Plate	2

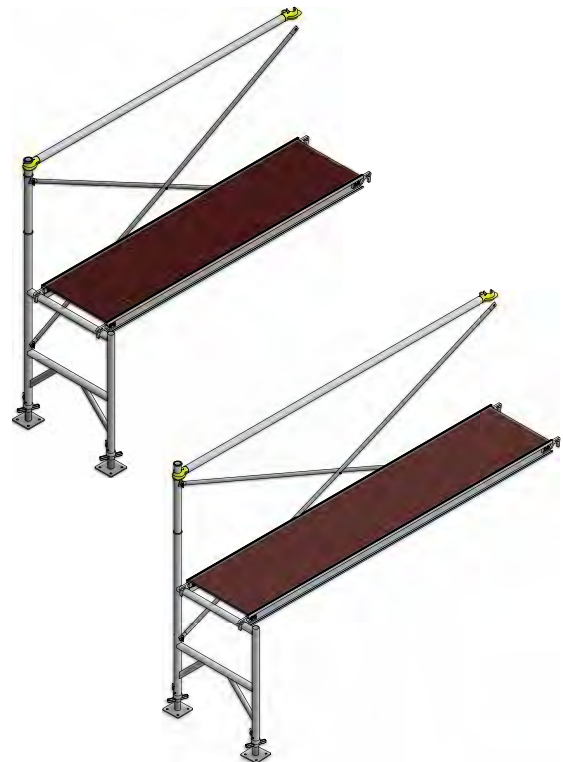

EASYREACH PACKS

14.4/18M STRAIGHT PACK

LLP05 - 14.4M	DESCRIPTION	BATCH QTY
LLF800	800 Multi Cross L Frame	7
CBM110	Multi Frame Cross Brace 2.4m	6
PFS435	Standard Platform 2.4m	6
GRB420	Snaplock Guardrail 2.4m	6
BPA605	Adj Base Plate	14

LLP06 - 18M	DESCRIPTION	BATCH QTY
LLF800	800 Multi Cross L Frame	7
CBM310	Multi Frame Cross Brace 3m	6
PFS440	Standard Platform 3m	6
GRB430	Snaplock Guardrail 3m	6
BPA605	Adj Base Plate	14



60M HOUSE-LOT

LLP07 - 60M	DESCRIPTION	BATCH QTY
LLF800	800 Multi Cross L Frame	20
CBM110	Multi Frame Cross Brace 2.4m	10
PFS435	Standard Platform 2.4	10
GRB420	Snaplock Guardrail 2.4	10
BPA605	Adj Base Plate	40
CBM310	Multi Frame Cross Brace 3m	6
PFS440	Standard Platform 3m	10
GRB430	Snaplock Guardrail 3m	14
IHP	Intermediate Handrail Post	4
LAG0.5	Self Closing Swing Gate	4
GRL300	3.0m Reinforced Grasper Ledger	2



EASYREACH COMPONENTS

ACCESS FRAME		BPA605 ADJUSTABLE BASE JACK		SNAPLOCK GUARDRAIL	
					
CODE	DESCRIPTION	CODE	DESCRIPTION	CODE	DESCRIPTION
LLF800	Access Frame	BPA605	Adjustable Base Jack	GRB410	Snaplock Guardrail 1.0m
				GRB415	Snaplock Guardrail 1.5m
				GRB420	Snaplock Guardrail 2.4m
				GRB430	Snaplock Guardrail 3.0m
REINFORCED SNAPLOCK LEDGER		SELF-CLOSING SWING GATE		PLATFORMS	
					
CODE	DESCRIPTION	CODE	DESCRIPTION	CODE	DESCRIPTION
GRL240	2.4m Reinforced Grasper Ledger	LAG0.5	Ladder Access Gate	PFS410	Standard Platform 1.0m
GRL300	3.0m Reinforced Grasper Ledger			PFS415	Standard Platform 1.5m
				PSF435	Standard Platform 2.4m
				PSF440	Standard Platform 3.0m
ALUMINIUM EASYRAIL TUBE		SCREW JACKS		INTERNAL JOINING SPIGOT	
					
CODE	DESCRIPTION	CODE	DESCRIPTION	CODE	DESCRIPTION
IHP	Intermediate Handrail Post	FHM800	800mm Wide Multi Cross Member Frame	CBM110	Multi Cross Member Cross Brace 2.4m
		HFF800	800mm Wide Multi Cross Member Half Frame	CBM310	Multi Cross Member Cross Brace 3.0m

EASY ACCESS CO SALES AND SERVICE POLICY FOR STORES

HOW CAN WE HELP YOU?

Our Customer Care team is available via phone or email during our regular office hours shown below.

We will answer any of your questions and help to make it easy for you sell Easy Access products to your customers.

Alternatively, you may find what you need on our website, where all of our products are profiled. Our website also provides you with:

- Downloadable Assembly Instructions
- Helpful Info Sheets
- Show-Me and How-To Product Videos

CUSTOMER SERVICE HOURS AND CONTACT DETAILS

MONDAY - FRIDAY (Excluding public holidays) - 7AM - 5PM

Phone: 0800 394 222 or +64 9 431 1055

Email: sales@easyaccess.co.nz

Web: www.easyaccess.co.nz

ENTERING ORDERS:

Here at Easy Access Co. we are delighted to offer you easy ordering; simply send in an order via the below method before 10am and we will aim to dispatch your goods the same day! This excludes products that are made to order, which will have a longer lead-time.

For prompt entry of your orders:

- Email to sales@easyaccess.co.nz
- Call us on 0800 394 222

You will receive a email back with an order confirmation when the order has been entered into our system.

If there is an item on back order this will be noted on the order confirmation along with an estimated due date. In the case that the due date changes again we will endeavor to keep you updated with a phone call.

RETURNS

Easy Access Co. is happy to accept product back if your customer changes their mind and cancels the order. Unless sent in error by Easy Access Co, goods returned for credit will incur a restocking fee of 5% of the product value or minimum \$10.00 charge, whichever is greater. In such cases, the return freight costs may also be on-charged. Note; this offer applies to stocked standard product only.

FREIGHT-DAMAGED PRODUCTS

In the event that you receive an item or items that have been damaged in transit, Easy Access Co. is happy to replace the affected item/s providing it has been signed for as damaged on the Proof of Delivery. It is the responsibility of the receiver to check all deliveries thoroughly, sign for them appropriately and to advise us within 24 hours of receipt of the damaged goods.

Should a damaged product be discovered after signing for delivery, please contact us as soon as possible. While we will be unable to claim with the freight company, we may be able to provide another suitable resolution such as a discount on replacement items.

CREDIT REQUESTS

Please contact us should you require a credit for any reason. After gathering details we will issue a credit if deemed justifiable, or advise otherwise. We will be happy to discuss alternative solutions at the time.

Credit requests for faulty items - we will look into and replace any still within their warranty free of charge.

Some products may require inspection before a replacement is sent or the product is repaired.

INVOICES AND STATEMENTS

If you are currently receiving invoices and statements by post and would prefer it to via email, simply email accounts@easyaccess.co.nz with your preferred email address and we will update our system.

BROCHURES AND PRICELISTS

We offer free marketing materials on our products. Contact us if you would like to receive these in either hard copy or email. Make sure you are on our mailing list for regular promotions that you can use to provide your customers with super special deals for Easy Access equipment.



RESOURCES AND ASSISTANCE

FOR TRADES, AND USERS OF HEIGHT ACCESS PRODUCTS

While we offer our height access products for sale exclusively through our network of trade stores throughout New Zealand, we love to talk directly to the end users of our products. Please contact us to offer your feedback, or ask us for advice or assistance.

WHAT PRODUCT IS BEST FOR ME?

We can help you to decide which of the vast range of Easy Access products may be best for you. **Contact Us** and we will talk you through it over the phone, or arrange a **FREE visit to your site**.

HOW DO I ASSEMBLE MY EASY ACCESS PRODUCT?

How-To Videos are available on our website. **Instruction sheets** can also be downloaded from there, or **Contact Us** to have them sent to you, or to arrange onsite installation training for you and your staff.

WHERE CAN I VIEW OR BUY EASY ACCESS PRODUCTS?

Our website has a **STORES** page. You can select your region to find where you can buy Easy Access products near you. Or **Contact Us** by **email** or **phone** if you would like us to provide you with the product code, where near you it is most likely to be in stock, and an indication of the price.

I HAVE A SUGGESTION

Great! We love feedback. If you have a suggested improvement to a product, or perhaps an idea for a new product, please **Contact Us**. If your suggestion solves a height access challenge not currently met - our NZ-based Design, Development and Production teams would love to know about it.

CAN I PURCHASE INDIVIDUAL COMPONENTS?

Most Easy Access products are part of a modular interchangeable system. Easy Access Components are profiled within the relevant sections in this catalogue. **Contact Us** if you need a replacement part on our products.

HEIGHT ACCESS SAFETY TRAINING

Keeping up with regulatory and site-specific safety standards can be complex - we are here to help. **Contact Us** if you would like us to arrange **FREE onsite height access training** or if you require clarification on **Safety standards and regulations**.

WHAT SPECIAL OFFERS ARE AVAILABLE FOR EASY ACCESS PRODUCTS RIGHT NOW?

Easy Access products are occasionally available on promotional deals which have been jointly arranged between Easy Access and our distributor network. **Contact Us** or visit our **website** to register for email updates on upcoming specials and product offers.

DOES EASY ACCESS MODIFY OR MANUFACTURE BESPOKE PLATFORMS TO SUIT MY EXACT HEIGHT ACCESS SITUATION?

We certainly do. **Contact Us** with your challenge and we will design, draw and fabricate a platform or product that will meet your requirements.

WE WOULD **LOVE** TO HEAR FROM **YOU!**

CALL US

0800 394 222

EMAIL US

sales@easyaccess.co.nz

VISIT OUR WEBSITE

www.easyaccess.co.nz

CONNECT WITH US ON
SOCIAL MEDIA





Reach it the **easy** way

**HEAD OFFICE MANUFACTURING
AND NORTHERN DISTRIBUTION**

334 Main Highway 12,
Maungaturoto, New Zealand
PO Box 62, Maungaturoto
Northland, New Zealand 0547

SOUTHERN DISTRIBUTION CENTRE

9 Venning Crescent, Cromwell 9310

FREEPHONE 0800 394 222

P +64 9 431 1055

F +64 9 431 8110

www.easyaccess.co.nz

