

Branch-2 Wardrobe Unit

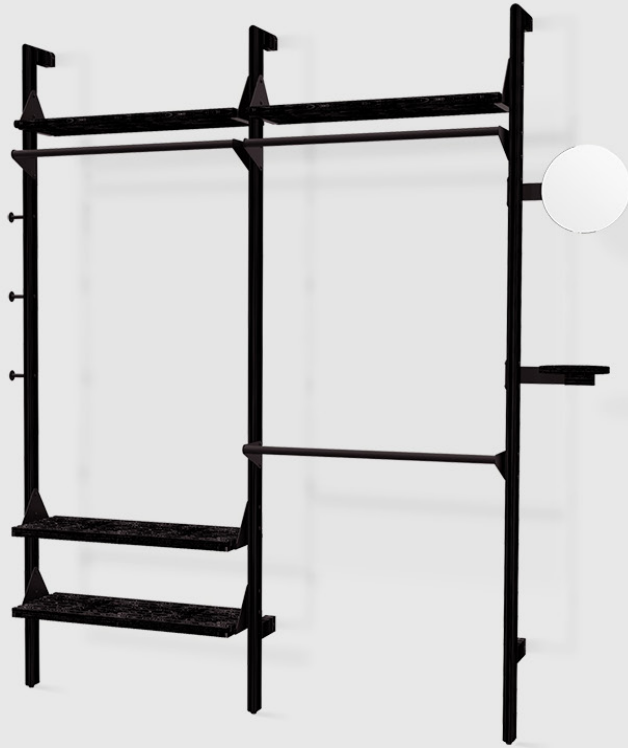

Blonde Uprights/
White Brackets/
Blonde Shelves



Black Uprights/
Black Brackets/
Black Shelves



Black Uprights/
Black Brackets/
Blonde Shelves

The Branch Shelving System blends mid-century style with modular components that give you an infinite number of elegant, open-storage options for home or office. The design features varying bookshelf configurations that can be transformed into a seamless workspace with the addition of a desk unit. Additional add-on units let you customize the size and layout of your shelving system to perfectly suit your space, and the shelves are height adjustable to suit any arrangement of decorative items or resources. Refined details, such as rounded edges on the shelves and uprights, soften Branch aesthetic and enhance its architectural style.

Straightforward installation means you can spend more time perfecting your vision and display.

Design Trade Professionals: We aim to keep our designs in stock and ready to ship quickly for projects on a tight timeline. Designs may be customized with COM and alternate finishes (minimum quantities may apply). Visit gusmodern.com for more information about our Trade & Contract programs.

Branch-2 Wardrobe Unit

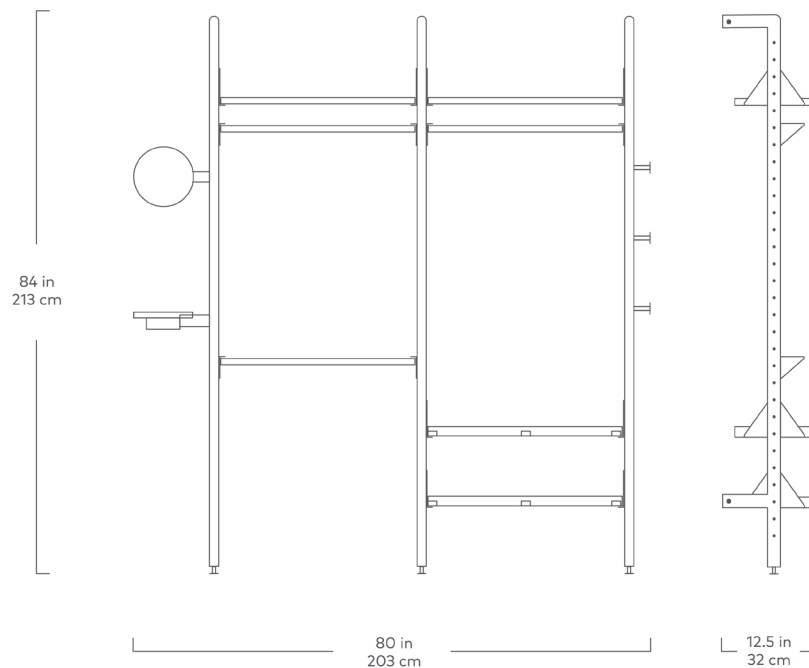

- Comprised of: 3 Branch Uprights, 2 Slatted Shelves, 2 Shelves, 3 Hangbars, 1 Side Mirror, 1 Side Tray and a set of 3 Single Hooks.
- Additional Add-Ons may be purchased to customize the configuration.
- Solid Ash Uprights and Side Tray are all FSC®-Certified in support of responsible forest management (FSC® 092551).
- Solid wood bullnose edge detail on Shelf.
- Side Mirror is 10" diameter.
- Side Tray features a CNC-routed recess detail.
- Powder-coated steel accents.
- Shelves and Add-ons are height-adjustable.
- Actual depth of Shelf is 11".
- Actual depth of Slatted Shelf is 12".
- Components can be adjusted vertically in 2.5" increments.
- Max. weight per shelf/hangbar is 50lbs. Max weight per side tray and single hook is 10 lbs. Max weight per bay is 250lbs.
- Assembly required. All hardware and instructions provided.
- CARB Phase II, ANSI-BIFMA, and TSCA Title VI Compliant.
- Wood is a natural material, with variations in grain pattern and colour that make each design unique.

