

AiM User Guide

EVO4S, SOLO 2/SOLO 2 DL kit
for BMW S1000RR (2010-2019)

Release 1.01



KIT





1

Models and years

This manual explains how to connect EVO4S and SOLO 2 DL to the bike engine control unit (ECU) and how to install AiM SOLO 2/SOLO 2 DL on the bike steering plate.

Compatible models are:

- BMW S1000RR 2009 – 2014
- BMW S1000RR 2015 – 2019
- BMW S1000RR HP4 2013 – 2014

Warning: for these models/years AiM recommends not to remove the stock dash. Doing so will disable some of the bike functions or safety controls. AiM Tech srl will not be held responsible for any consequences that may result from the replacement of the original instrumentation cluster.

2

Kit content and part numbers

AiM developed a specific installation bracket for SOLO 2/SOLO 2 DL and a connection cable to the ECU for EVO4S/SOLO 2 DL.

2.1

Bracket for SOLO 2/SOLO 2 DL

Part number for **SOLO 2/SOLO 2 DL** installation bracket for **BMW S1000RR** – shown below – is: **X46KSBMWS1**.

Installation kit contains:

- 1 bracket (1)
- 1 allen screw with rounded head M8x45mm (2)
- 1 toothed washer (3)
- 2 allen screws with flat head M4x10mm (4)
- 1 rubber dowel (5)
- 1 spacer (6)



2.2 AiM cable for SOLO 2 DL

Part number for **SOLO 2 DL** connection cable for **BMW S1000RR** – shown below – is: **V02569230**.



Following image shows the cable constructive scheme:

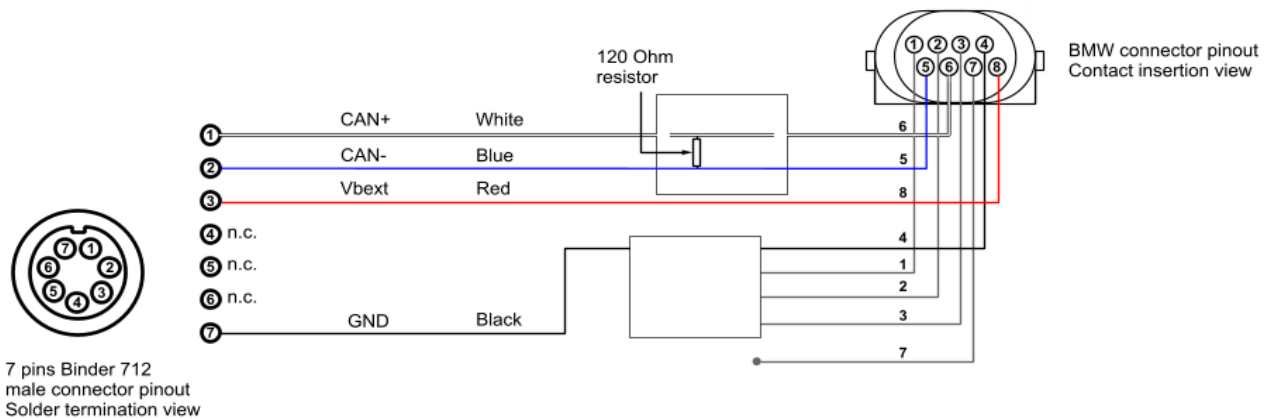

Installation bracket and connection cable for SOLO 2 DL for BMW S1000RR can be bought together. Part number: **V0256923CS**.

2.3 AiM cable for EVO4S

Part number for **EVO4S** connection cable for **BMW S1000RR** – shown below – is: **V02585140**.



Following image shows the cable constructive scheme:

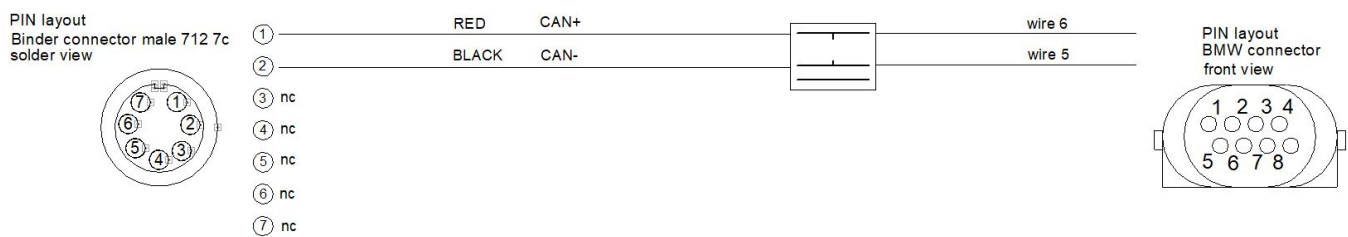

3

EVO4S/SOLO 2 DL connection

To connect EVO4S/SOLO 2 DL to the BMW S1000RR ECU use the connector placed under the bike tail and shown here below:

The image on the right shows the connector in detail.



4

Configuration with Race Studio 3

Before connecting EVO4S/SOLO 2 DL to the bike ECU, set all functions using the AiM software Race Studio 3. The parameters to set in the AiM device configuration section are (“ECU Stream” tab):

ECU Manufacturer: **BMW**

ECU Model:

- **BIKE_S1000RR** for BMW S1000RR 2009 - 2014 and BMW S1000RR HP4 2013 - 2014
- **BIKE_S1000RR_2015** for BMW S1000RR 2015 – 2019

After this first selection, enable/disable the 120Ohm resistor and the “Silent” mode on CAN Bus as follows, according to the used device:

EVO4S

<input checked="" type="checkbox"/>	Enable the CAN Bus 120 Ohm Resistor
<input checked="" type="checkbox"/>	Silent on CAN Bus

SOLO 2 DL

<input type="checkbox"/>	Enable the CAN Bus 120 Ohm Resistor
<input checked="" type="checkbox"/>	Silent on CAN Bus



5

BMW protocols

Available channels change according to the selected protocol.

5.1

"BMW - BIKE_S1000RR" protocol

Received channels by EVO4S/SOLO 2 DL configured with "BMW – BIKE_S1000RR" protocol are:

CHANNEL NAME	FUNCTION
RPM	RPM
HP4SpeedF2	Front wheel speed - HP4
HP4SpeedBike	Vehicle speed - HP4
HP4SpeedR2	Rear wheel speed - HP4
SpeedF	Front wheel speed
SpeedR	Rear wheel speed
TPS	Throttle position sensor
PPS	Accelerator handgrip position sensor
WaterTemp	Water temperature
Neutral	Neutral gear sensor
Clutch	Clutch switch
Side Stand Sw	Side stand switch
BrakeF	Front brake pressure
BrakeR	Rear brake pressure
RollRate	Roll rate
LatAcc	Lateral accelerometer
YawRate	Yaw rate
VertAcc	Vertical accelerometer



LongAcc	Longitudinal accelerometer
HP4LongAcc	Longitudinal accelerometer - HP4
ABSOff	ABS off status (alarm)
HP4PotF	Front suspension potentiometer - HP4
HP4PotR	Rear suspension potentiometer - HP4
HP4Banking	Banking angle - HP4
BrkFail	Brake failure (error)
TCact	Traction Control active status
HP4SelTC	Traction Control selection – HP4
TCOff	Traction Control OFF status (alarm)
IntakeAirTemp	Intake air temperature
ChkEngine	Engine status check (alarm)
OilPressSw	Oil pressure switch (alarm)
EWSCtrl	EWS control
SelMap	Engine map selection
MapMenu	Engine map menu

Technical note: not all data channels outlined in the ECU template are validated for each manufacturer model or variant; some of the outlined channels are model and year specific, and therefore may not be applicable; channels labelled “HP4” are only available on **BMW S1000RR HP4 2013-2014** bikes.



5.2

"BMW - BIKE_S1000RR_2015" protocol

Received channels by EVO4S/SOLO 2 DL configured with "BMW - BIKE_S1000RR_2015" protocol are:

CHANNEL NAME	FUNCTION
RPM	RPM
Gear	Gear
SpeedF	Front wheel speed
SpeedR	Rear wheel speed
LongAcc	Longitudinal accelerometer
LatAcc	Lateral accelerometer
VertAcc	Vertical accelerometer
RollRate	Roll rate
YawRate	Yaw rate
WaterTemp	Water temperature
IntakeAirTemp	Intake air temperature
BrakePressF	Front brake pressure
BrakePressR	Rear brake pressure
Banking	Banking angle
TPS	Throttle position sensor
HandTPS	Handgrip throttle position sensor
MomTotRedu	Total torque reduction
ASCTrqReduct	Torque reduction by Automatic Stability Control
ASCTyreGrip	Tyre grip by Automatic Stability Control
WheelMomAct	Actual wheel torque
LaunchCtrl	Launch control
TC Sel	Traction control level selection
ABSActive	ABS active status
LiftOff	Lift control



DamperFmm	Front dampers travel in mm
DamperRmm	Rear dampers travel in mm
InjFuelmL	Fuel injection (millilitres)
OilLevelLow	Low oil level switch (alarm)
ASCON	Automatic Stability Control ON status
MIL	Malfunctioning indicator lamp (alarm)
RRebound Set	Rear dampers rebound set
FRebound Set	Front dampers rebound set
RBump Set	Rear dampers bump set
FBump Set	Front dampers bump set

Technical note: note all data channels outlined in the ECU template are validated for each manufacturer model or variant; some of the outlined channels are model and year specific, and therefore may not be applicable.