

LKSm

Self-priming Peripheral Pump

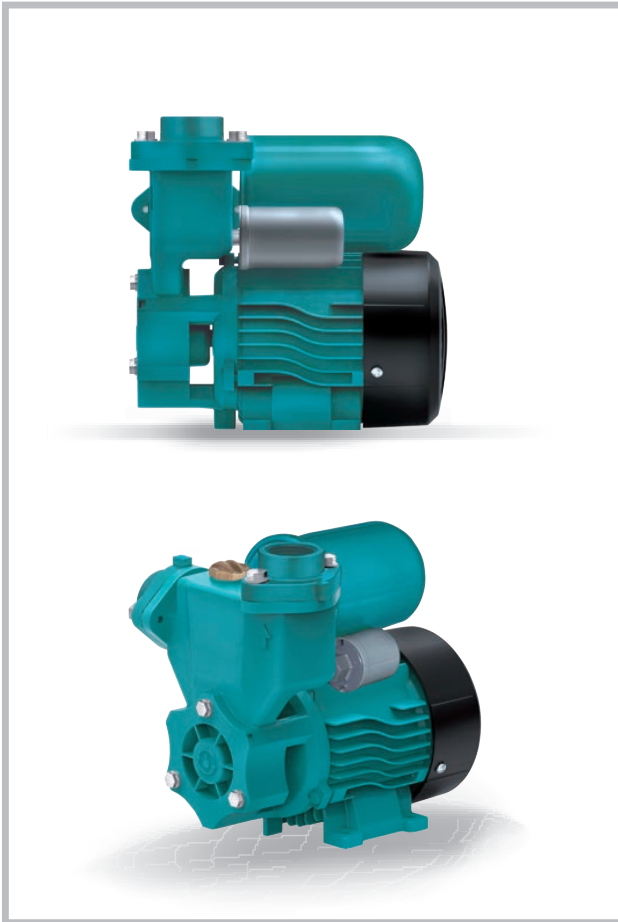

Application

- Can be used to transfer clean water or other liquids similar to water in physical and chemical properties
- Suitable for small living water supply, automatic water sprinkler system, small air conditioner system or supporting equipment etc.

Pump

- With 2 L pressure tank for automatic operation
- Special anti-rust treatment
- Brass impeller
- AISI 304 shaft
- Max. liquid temperature: +40°C
- Max. suction: +9 m

Motor

- C&U bearing
- Copper winding
- Built-in thermal protector
- Insulation class: F
- Protection class: IPX4
- Max. ambient temperature: +40°C

Identification Codes

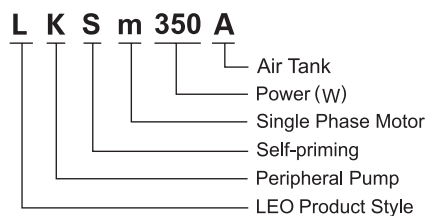

Technical Data

MODEL	POWER		Q (m ³ /h) Q (l/min)	0	0.3	0.6	0.9	1.2	1.5	1.8	2.1	2.4	2.7	3
	kW	HP		0	5	10	15	20	25	30	35	40	45	50
LKSm130	0.125	0.17	H (m)	30	25	20.5	16	12	8	4	-	-	-	-
LKSm350A	0.35	0.47		35	32	28	24	20	16	12	8	4	-	-
LKSm550A	0.55	0.75		45	40	35	30	25	20.5	16	12	8	4	-
LKSm750A	0.75	1		55	50	45	40	35	30	25	20	15	10	5

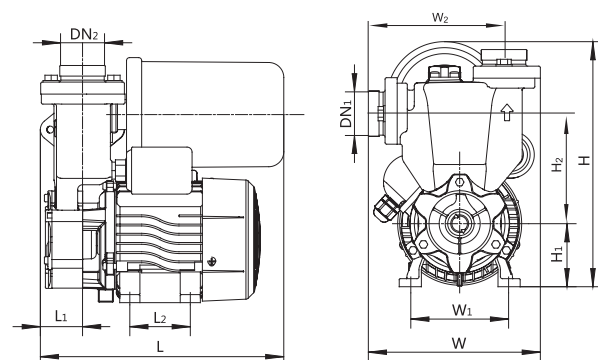

2 YEAR WARRANTY

Dimension

Model	DN1	DN2	L (mm)	W (mm)	H (mm)	L ₁ (mm)	W ₁ (mm)	W ₂ (mm)	H ₁ (mm)	H ₂ (mm)
LKSm130	1"	1"	265	165	245	60	97	140	63	107.5
LKSm350A			265	165	250	60	97	135	63	110
LKSm550A			265	176	260	90	112	146	75	113.5
LKSm750A			265	176	260	90	112	146	75	113.5



Hydraulic Performance Curves

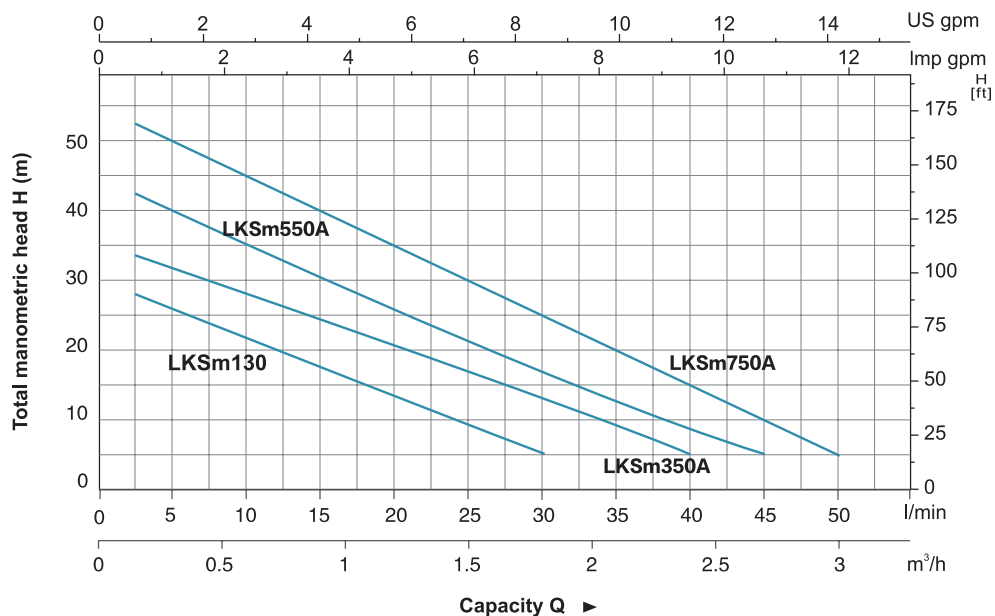

Materials Table

No.	Part	Material	No.	Part	Material
1	Pump bonnet	Brass/Cast iron	18	Capacitor	
2	Impeller	Brass	19	Cable holder	NBR
3	Mechanical seal	Carbon/Ceramic	20	Sealing ring	NBR
4	Pump body	HT200	21	Terminal box	ABS
5	Check valve	NBR			
6	Outlet connector	HT200			
7	Filling plug	Brass			
8	Front plate	HT200			
9	Bend	Iron			
10	Pressure switch				
11	Pressure tank	Iron			
12	Bearing				
13	Rotor				
14	Fan cover	PP			
15	Fan	PP			
16	Rear cover	ZL102			
17	Stator				

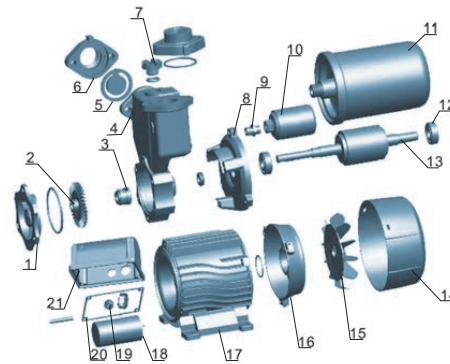

Package Information

Model	CW (Kgs)	L (mm)	W (mm)	H (mm)	Quantity (PCS/20 TEU)
LKSm130	7.8	285	195	290	1603
LKSm350A	8.6	285	195	290	1603
LKSm550A	11.6	290	215	305	1400
LKSm750A	13.5	290	215	310	1400



LKSm

16

2 YEAR WARRANTY