

AMS

Stainless Steel Centrifugal Pump



Application

- It is applicable to household water supply, equipment support, pipeline pressurization, garden watering, vegetable greenhouse watering, fish farming and poultry raising, industrial and mining, water supply and drainage of enterprises and high-rise buildings, central air conditioner and centralized heating circulation system, etc.

Pump

- AISI 304 pump body
- AISI 304 shaft
- Max. liquid temperature: +85°C
- Altitude: up to 1000 m

Motor

- C&U bearing
- Motor with copper winding
- Built-in thermal protector for single phase motor
- Insulation class: F
- Protection class: IPX4
- Max. temperature: +40°C

Identification Codes

A MS m 70 / 0.37

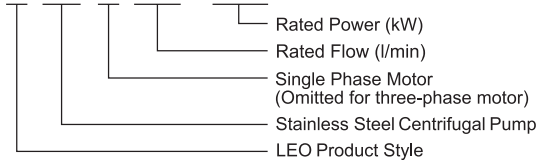

Technical Data

MODEL		POWER		Q (m ³ /h)	0	1.8	2.4	3.6	4.8	6	7.2	8.4	9.6	10.8
Single Phase	Three Phase	kW	HP	Q (l/min)	0	30	40	60	80	100	120	140	160	180
AMSm70/0.37	AMS70/0.37	0.37	0.5	H (m)	20.9	19.0	18.1	15.7	12.1	-	-	-	-	-
AMSm70/0.55	AMS70/0.55	0.55	0.75		29.5	27.3	26.3	23.4	19.1	-	-	-	-	-
AMSm70/0.75	AMS70/0.75	0.75	1.0		30.4	28.5	27.8	26.0	23.0	-	-	-	-	-
AMSm120/0.55	AMS120/0.55	0.55	0.75		20.2	-	-	17.9	16.6	15.1	13.3	11.2	8.7	-
AMSm120/1.1	AMS120/1.1	1.1	1.5		30.2	-	-	26.7	25.1	23.3	21.2	19.0	16.4	-

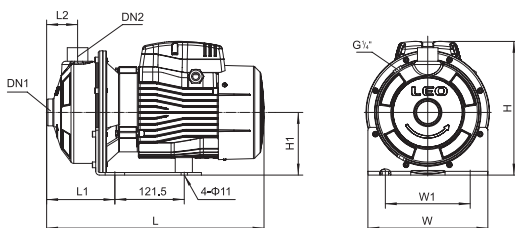

Dimension

Model	Ports		L (mm)	W (mm)	H (mm)	L ₁ (mm)	L ₂ (mm)	W ₁ (mm)	H ₁ (mm)
	DN1	DN2							
AMS70/0.37	1 1/4"	1"	332	210	224	119	55	149	110
AMS70/0.55	1 1/4"	1"	332	210	224	119	55	149	110
AMS70/0.75	1 1/4"	1"	381	210	234	119	55	149	110
AMS120/0.55	1 1/4"	1"	332	210	224	119	55	149	110
AMS120/1.1	1 1/4"	1"	381	210	234	119	55	149	110

2 YEAR WARRANTY

Hydraulic Performance Curves

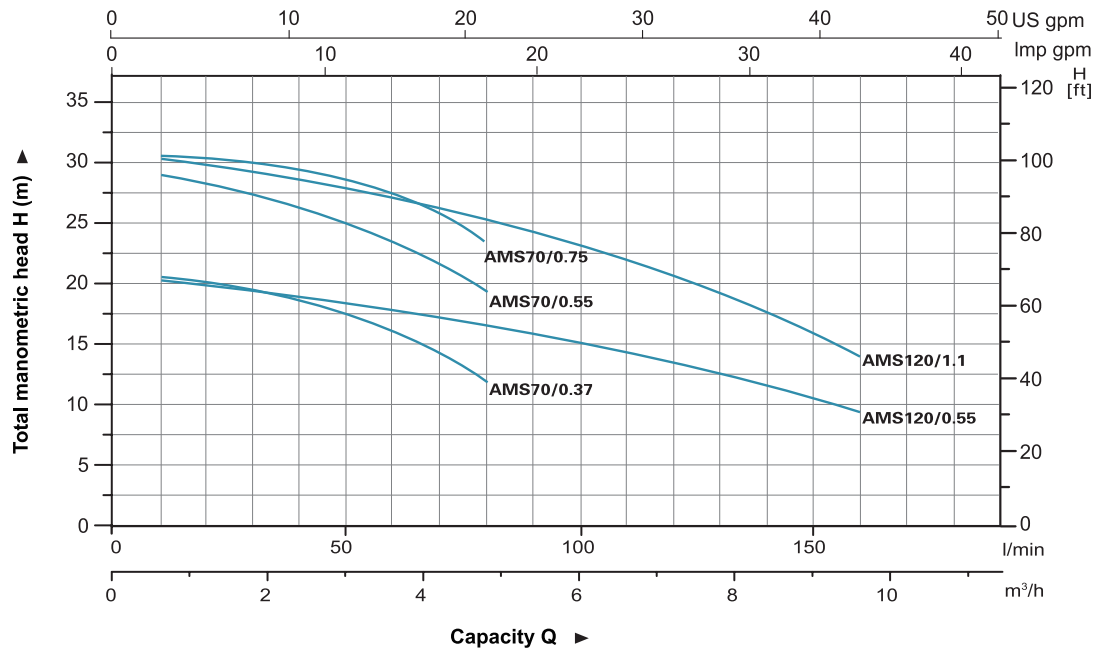

Materials Table

No.	Part	Material
1	Bottom support	Steel
2	Pump body	AISI 304
3	Diffuser	AISI 304
4	Impeller	AISI 304
5	O-ring	NBR
6	Airproof plate	AISI 304
7	Support	ZL102
8	Mechanical seal	Silicon/Carbon
9	Ball bearing	
10	Rotor	
11	Stator	
12	Fan	PP
13	Rear housing	ZL102
14	Fan cover	PP
15	Terminal box	ABS

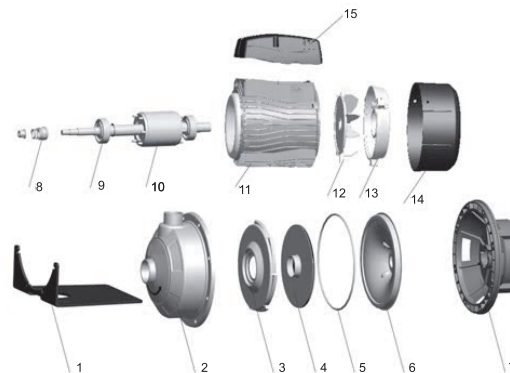

AMS

Package Information

Model	GW (Kgs)	L (mm)	W (mm)	H (mm)	Quantity (PCS/20 TEU)
AMS70/0.37	10	380	240	270	1200
AMS70/0.55	11	380	240	270	1200
AMS70/0.75	14	410	240	270	1104
AMS120/0.55	11	380	240	270	1200
AMS120/1.1	15	410	240	270	1104



2 YEAR WARRANTY