

PATENT N° US 11,274,451 GB 2563328 CA 3,001,5

SNAP'N LOCK®

BALUSTER KIT

INDOOR

INSTALLATION

- TOOLS REQUIRED -

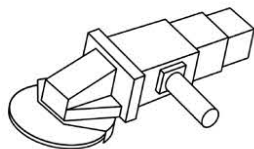

ELECTRIC GRINDER

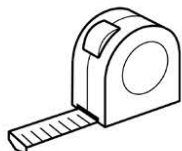

TAPE MEASURE



SCREW DRIVER

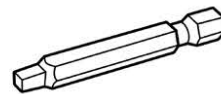

NO 2 PHILLIPS SQUARE DRIVER BIT

START

START

START

LANDINGS

(A)

36"

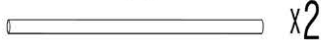

OR 42"

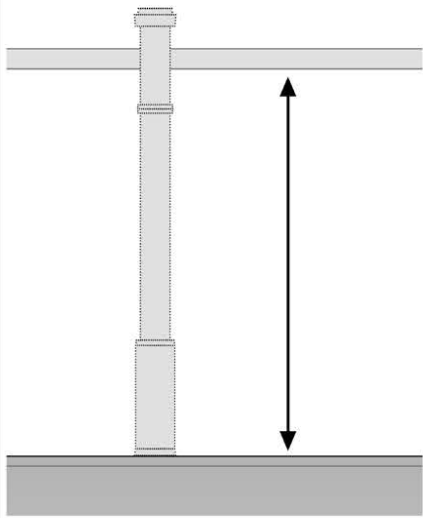

CLOSED STRINGERS

(B)

36"



OR 42"

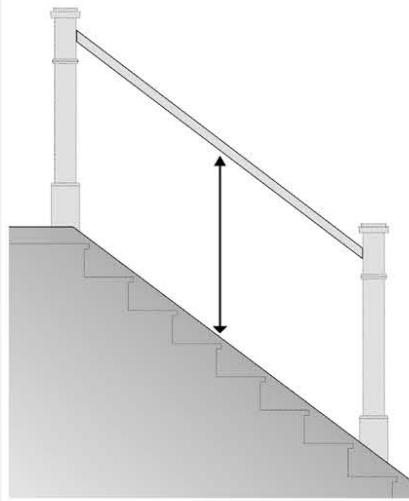

OPEN STRINGERS

(C)

38"

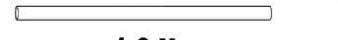

40"

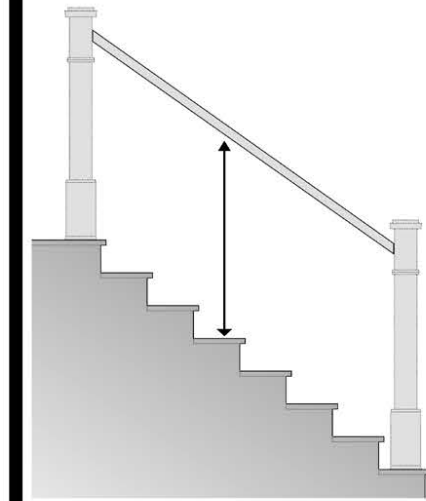
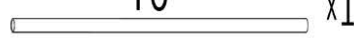

T 1-866-577-8868

TITAN BUILDING PRODUCTS®
THE ART OF BUILDING
More Outdoor Beauty... Real easy.



www.titanbp.com

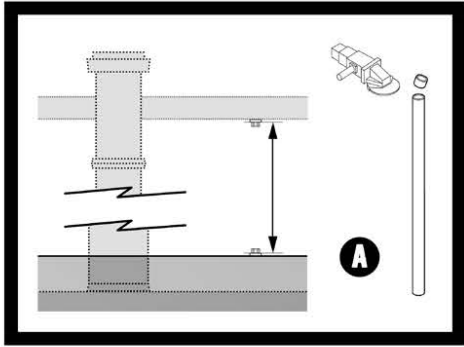

A

CONTINUE

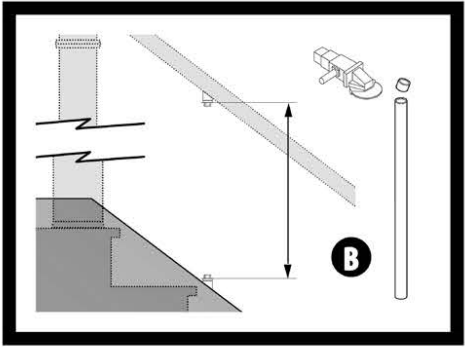

B

CONTINUE

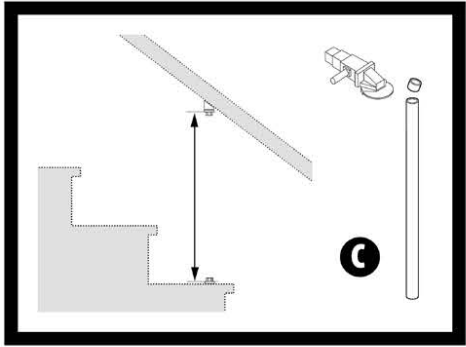

C

CONTINUE

LANDINGS **A**

1 STARTING FROM THE CENTER OF THE RAILS. MARK LINES AT 4-1/2" ON LOWER AND UPPER RAILS.

2 SCREW THE SHOE CONNECTORS TO UPPER/LOWER RAIL SURFACES.

UPPER SHOE	LOWER SHOE

3 CONNECT BALUSTERS AND COLLARS.

FINISH

CLOSED STRINGERS **B**

1 STARTING FROM THE CENTER OF THE RAILS. MARK LINES AT 5-1/2" ON LOWER AND UPPER RAILS.

2 ASSEMBLE SHOE AND STAIR ADAPTER.

SHOE & STAIR ADAPTER

	UPPER SHOE	UPPER ADAPTER
	LOWER SHOE	LOWER ADAPTER

7/8" x 2

TAP ADAPTER WITH HAMMER TO REGISTER GRIPPING CONES TO SUBSTRATE OR HANDRAIL.

FIT SHOE WITH ADAPTER.

DRILL HOLE FOR SCREW IF USING HARDWOOD RAILS. DRIVE SCREW TO SECURE CONNECTORS.

FINISH

OPEN STRINGERS **C**

1 ALLOW FOR TWO BALUSTERS PER TREAD.

2 SCREW THE SHOE CONNECTORS TO UPPER/LOWER RAIL SURFACES.

UPPER ADAPTER & SHOE	LOWER SHOE

3 SNAP IN BALUSTERS AND COLLARS.

FINISH