

JÜVTM

by ergotron®

Sit-Stand Panel Mounted Desk

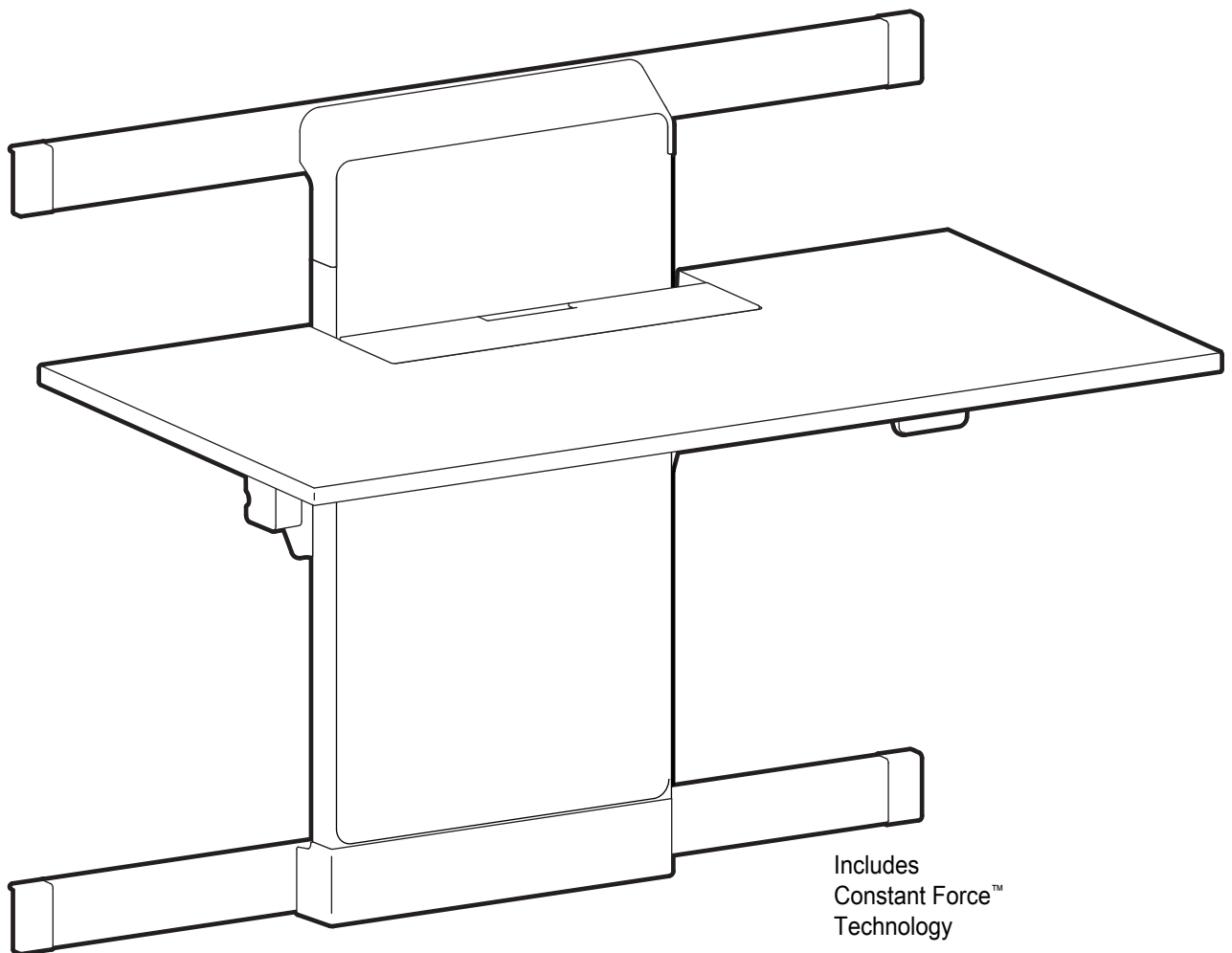

For the latest User Installation Guide please visit: www.ergotron.com

Para acceder a la última versión de la Guía de instalación para el usuario, ingrese a www.ergotron.com

Pour la dernière version du Guide d'installation de l'utilisateur, visitez : www.ergotron.com.



Warning: The panel system configuration that this product is installed on must conform to the panel manufacturer's Stability and Loading Guidelines. Failure to follow the guidelines may result in serious injury and/or property damage.

Caution: This Product Must be Mounted to a Vertical Surface. Failure to follow this instruction may result in serious injury and/or property damage.

The JUV Panel Worksurface can only be installed on the following Panel Systems in a "U" shaped configuration, with return panels on the worksurface mounted side: Hayworth Compose, Allsteel Terrace, Steelcase Answer, Herman Miller Canvas. No other items (shelves, stackers, etc) can be installed on these panels. The JUV Panel Worksurface configuration will have minimum and maximum requirements for the height and width of the rear panel and the return panels.

Rear panel height: min 50" (1270 mm), max 72" (1829 mm)

Rear panel width: min 36" (914 mm), max 60" (1524 mm)

Return panel height: min 30" (762 mm), max 72" (1829 mm)

Return panel depth: min = worksurface depth, no max

For Commercial Use Only.

Accessories (Ordered Separately)

1. JUV Single Electrical Kit for Sit-Stand Desk
2. JUV Laminate Insert

Advertencia: la configuración del sistema de paneles sobre el que se instala este producto debe cumplir con las Directrices de estabilidad y carga del fabricante del panel. El incumplimiento de estas directrices puede producir lesiones graves o daños materiales.

Precaución: este producto debe montarse sobre una superficie vertical. El incumplimiento de estas instrucciones puede producir lesiones graves o daños materiales.

The JUV Panel Worksurface can only be installed on the following Panel Systems in a "U" shaped configuration, with return panels on the worksurface mounted side: Hayworth Compose, Allsteel Terrace, Steelcase Answer, Herman Miller Canvas. No other items (shelves, stackers, etc) can be installed on these panels. The JUV Panel Worksurface configuration will have minimum and maximum requirements for the height and width of the rear panel and the return panels.

Rear panel height: min 50" (xx mm), max 72" (xx mm)

Rear panel width: min 36" (xx mm), max 60" (xx mm)

Return panel height: min 30" (xx mm), max 72" (xx mm)

Return panel depth: min = worksurface depth, no max

Solo para uso comercial.

Accesorios (se encargan por separado).

1. Kit eléctrico individual JUV de escritorio para trabajar de pie o sentado
2. JUV Laminate Insert

Avertissement : La configuration du système de panneaux sur lequel ce produit est installé doit être conforme aux directives de stabilité et de capacité de charge du fabricant du panneau. Le non-respect de ces directives peut entraîner des blessures graves et/ou des dommages matériels.

Attention : Ce produit doit être monté sur une surface verticale. Le non-respect de cette consigne peut entraîner des blessures graves et/ou des dommages matériels.

The JUV Panel Worksurface can only be installed on the following Panel Systems in a "U" shaped configuration, with return panels on the worksurface mounted side: Hayworth Compose, Allsteel Terrace, Steelcase Answer, Herman Miller Canvas. No other items (shelves, stackers, etc) can be installed on these panels. The JUV Panel Worksurface configuration will have minimum and maximum requirements for the height and width of the rear panel and the return panels.

Rear panel height: min 50" (xx mm), max 72" (xx mm)

Rear panel width: min 36" (xx mm), max 60" (xx mm)

Return panel height: min 30" (xx mm), max 72" (xx mm)

Return panel depth: min = worksurface depth, no max

Pour usage commercial seulement.

Accessoires (à commander séparément)

1. Kit électrique simple JUV pour bureau assis-debout
2. JUV Laminate Insert

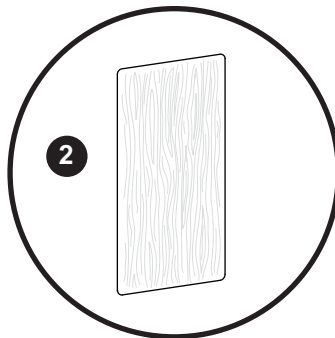
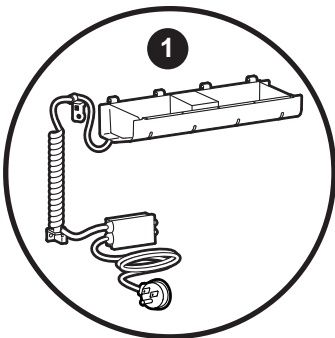

Tools Needed
Herramientas necesarias
Outillage requis

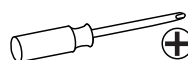

		A	B	C	D
1	1x		1x	2x	2x
			1x		
			1x	2x	14x
			1x		#10-9 x 1"
2				ST4.2 x 13mm	
3					
4					

		A	B	C
1	1x		1x	3x
				M5x14mm

		A	B	C	D	E
1	1x		1x	1x	1x	8x
						M4x14mm

		A
1	1x	

1

Attach bottom brackets to panel.
Fije las abrazaderas inferiores al panel.
Fixez les supports inférieurs au panneau.

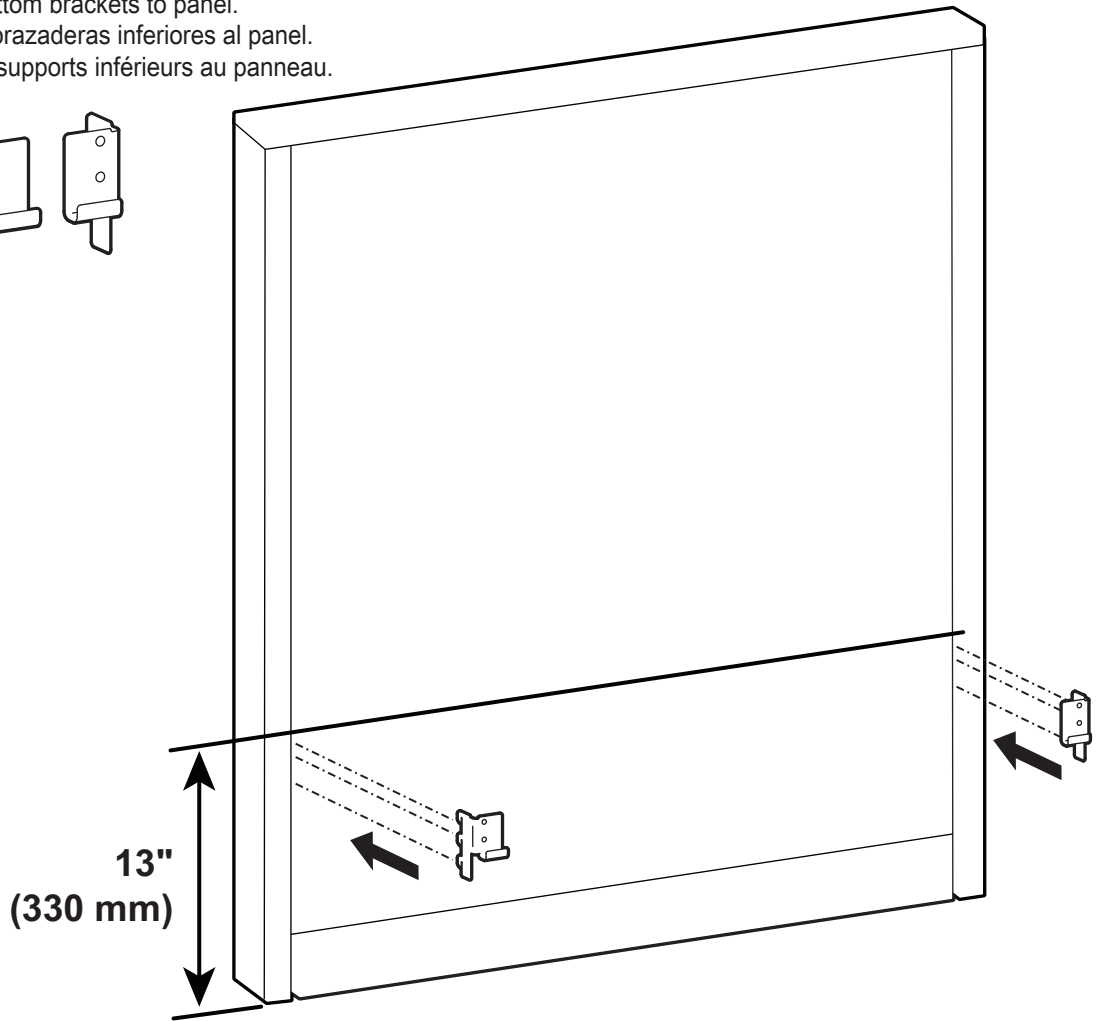
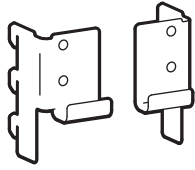

2

Attach Bottom bar to brackets.
Fije la barra inferior al panel.
Fixez la barre du bas aux supports.

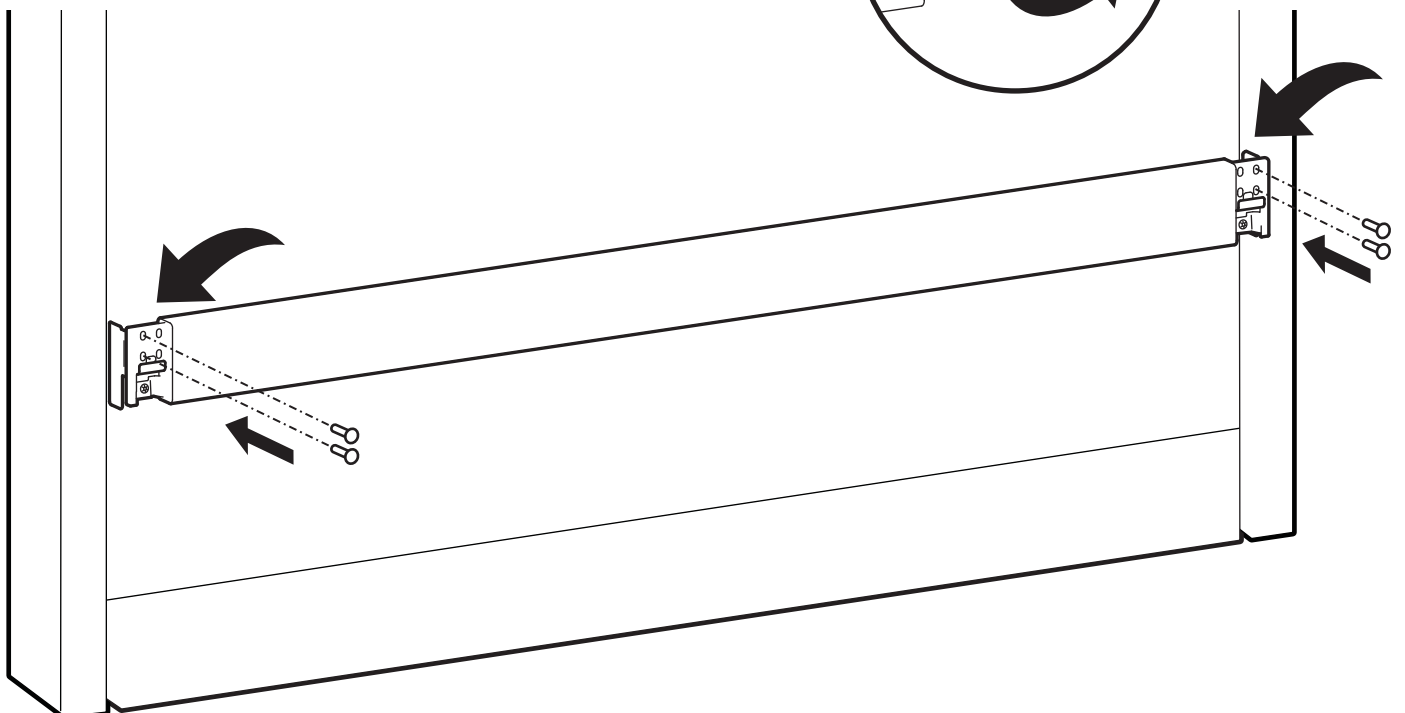
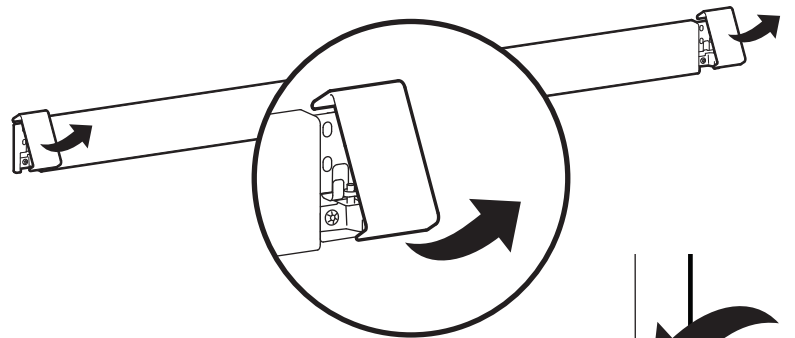

3

1. Loosen top brackets.
2. Attach brackets to panel.
3. Tighten brackets to secure.

1. Afloje las abrazaderas superiores.
2. Fije las abrazaderas al panel.
3. Apriete las abrazaderas para asegurarlas.

1. Desserrez les supports supérieurs.
2. Fixez les supports au panneau.
3. Serrer les supports pour bien les fixer.

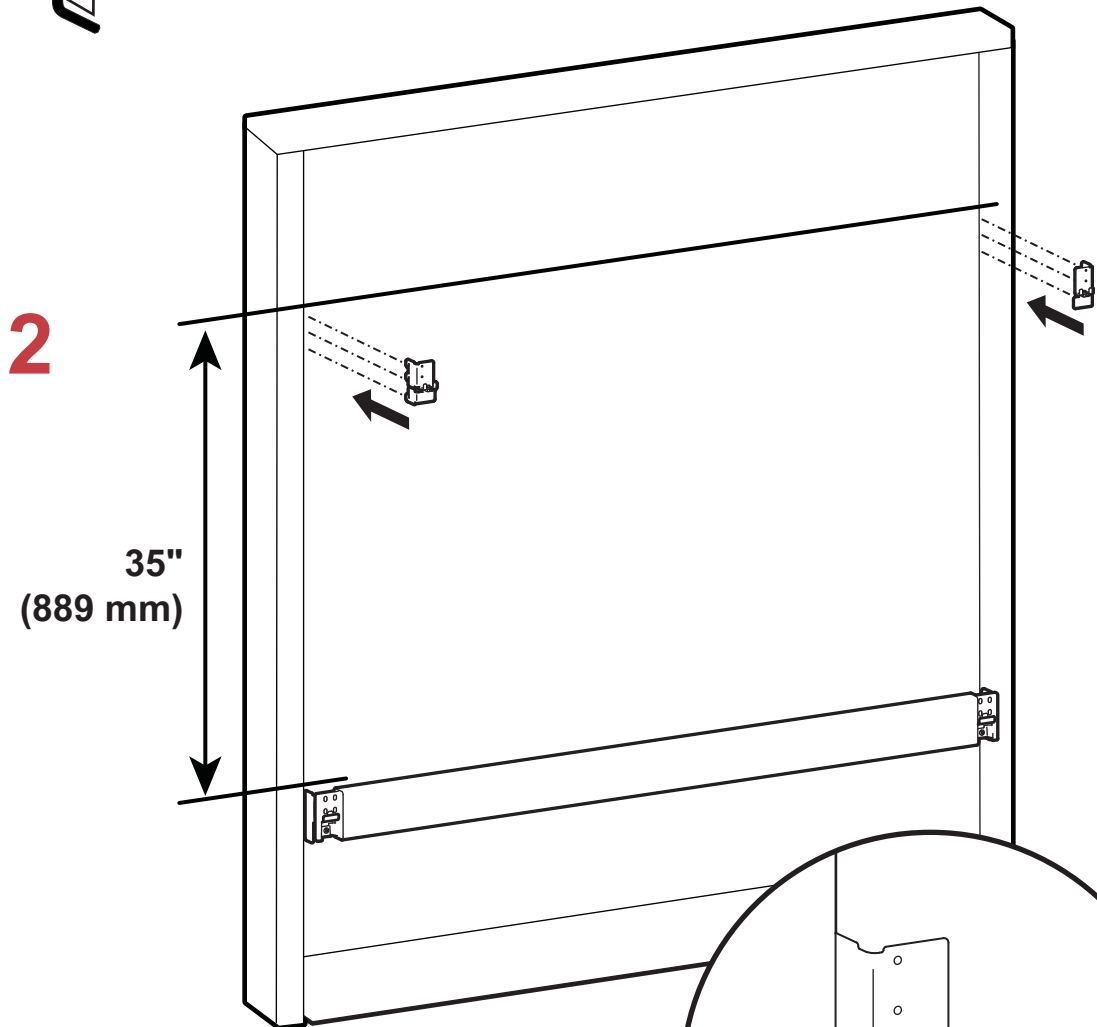
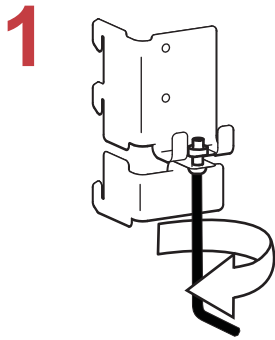
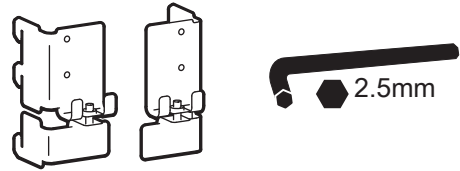

4

Attach top bar to lift engine.
Fije la barra superior al motor de elevación.
Fixez la barre supérieure au moteur de levage.

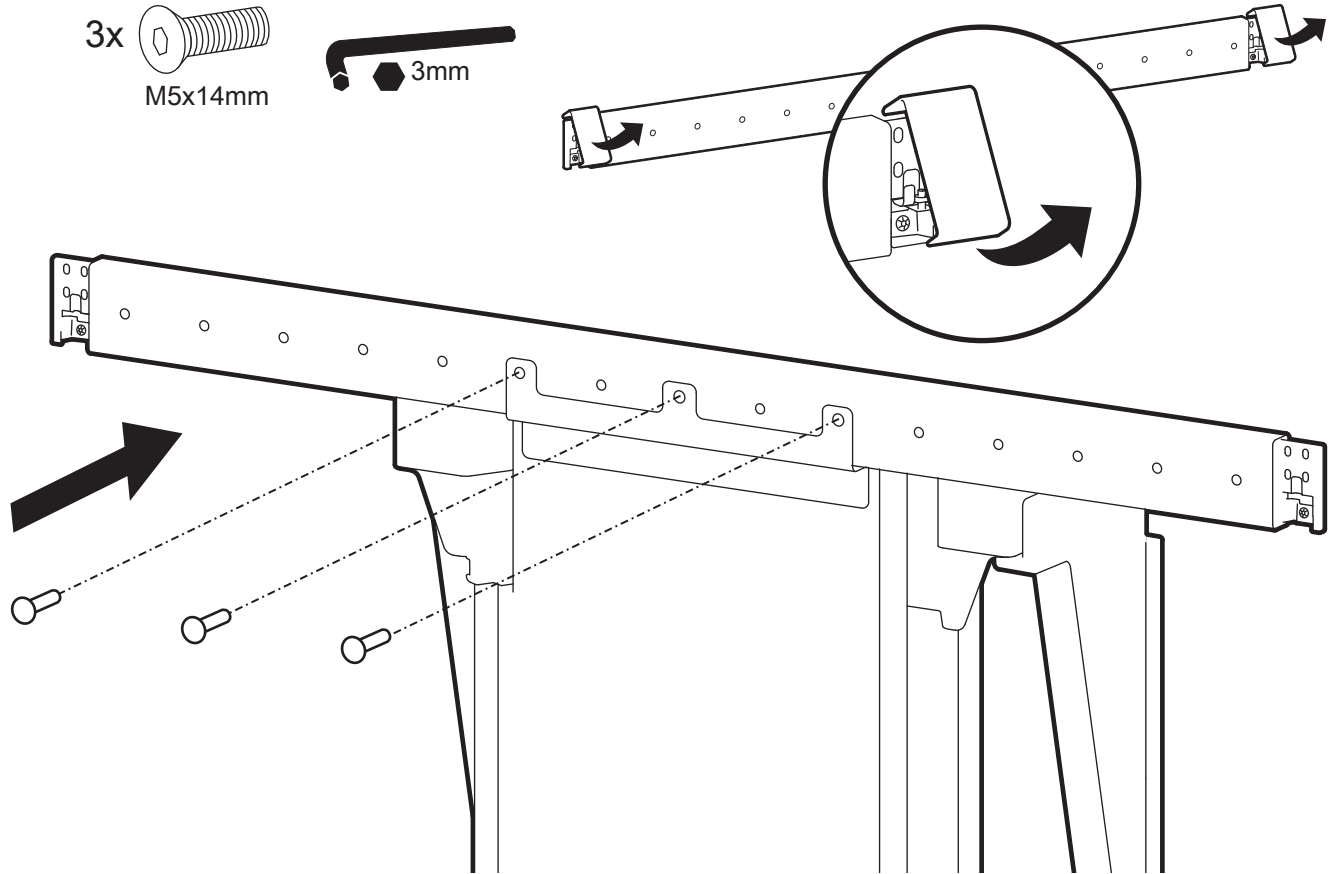

Attach lift engine to the appropriate set of holes on the top bar to achieve your desired horizontal location on the panel.

Conecte el motor de elevación al juego de orificios adecuado situado en la barra superior para lograr la ubicación horizontal deseada en el panel.

Fixez le moteur de levage à l'ensemble de trous de la barre supérieure afin d'obtenir le positionnement horizontal désiré sur le panneau.

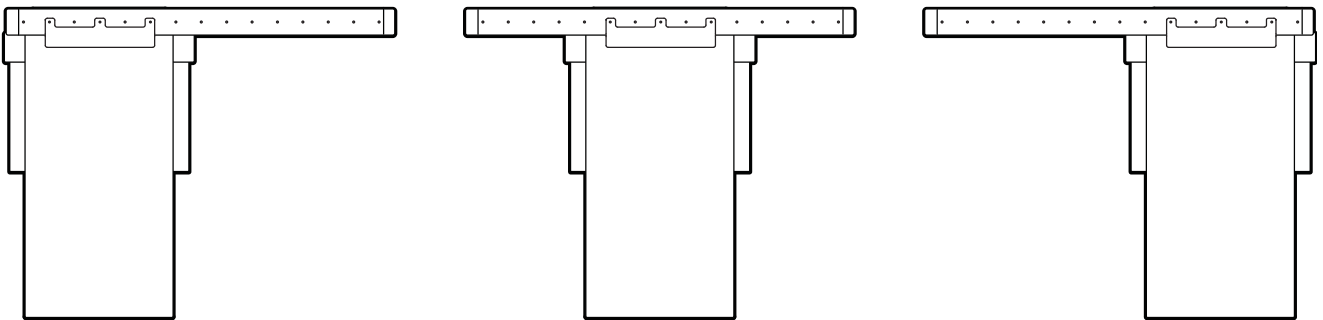

5

Hook lift engine onto bottom bar while top bar hooks onto top brackets (2 person lift).

Enganche el motor a la barra inferior mientras que la barra superior se engancha a las abrazaderas superiores (elevación para 2 personas).

Accrochez le moteur de levage à la barre inférieure tandis que la barre supérieure s'accroche aux supports supérieurs (levage par 2 personnes).



4x  M4x14mm  3mm

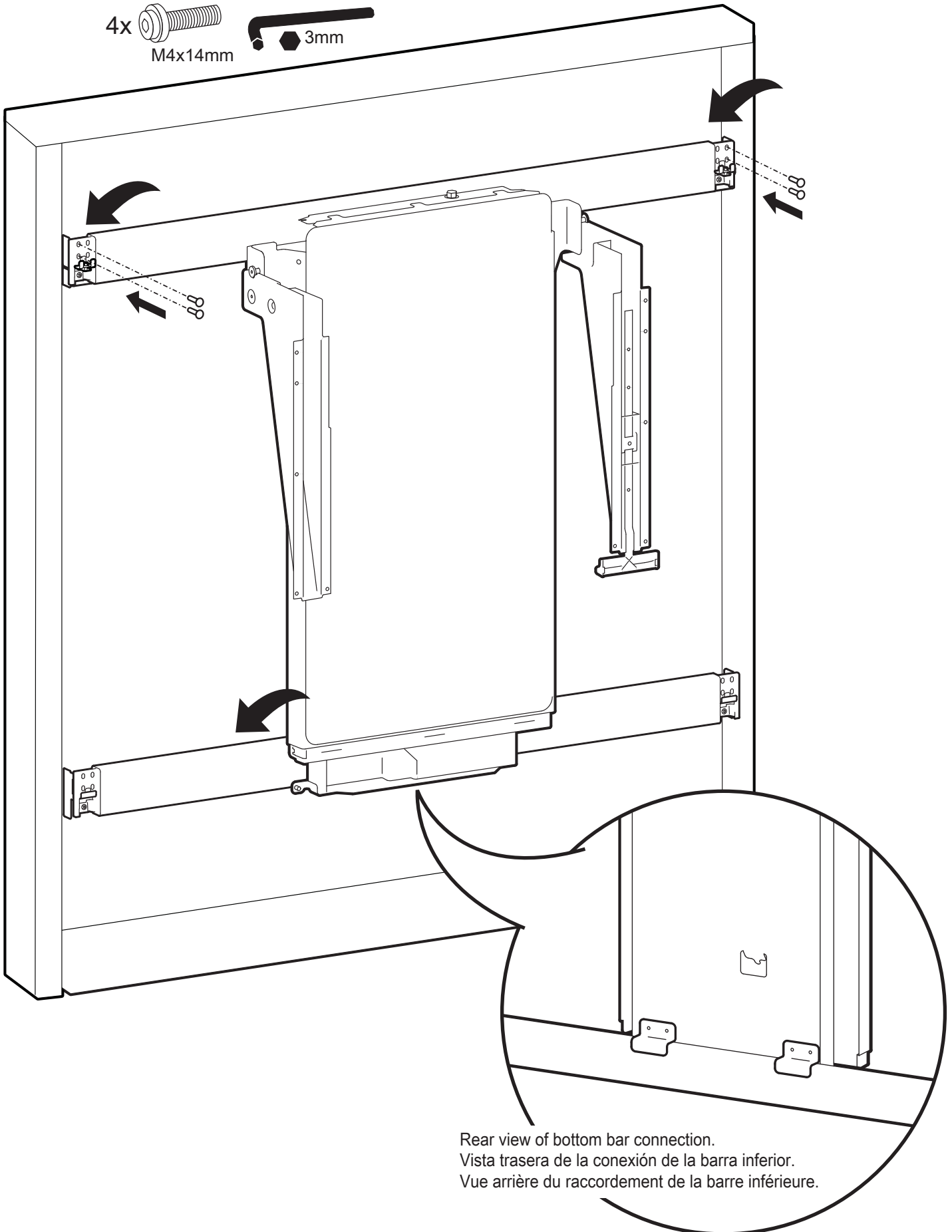

Rear view of bottom bar connection.
Vista trasera de la conexión de la barra inferior.
Vue arrière du raccordement de la barre inférieure.

6

Attach bracket covers.
Fije las cubiertas de las abrazaderas.
Fixez les protections des supports.

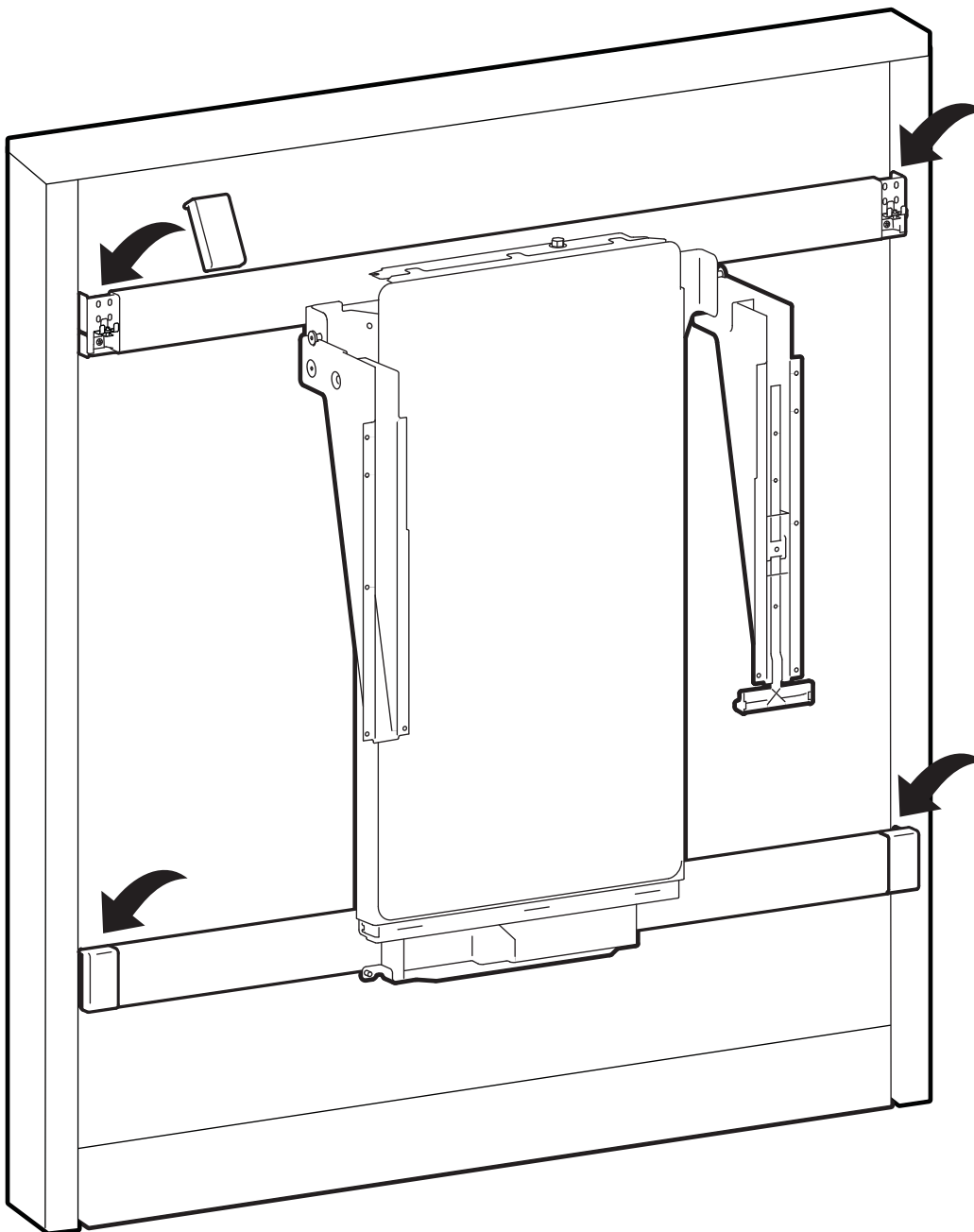
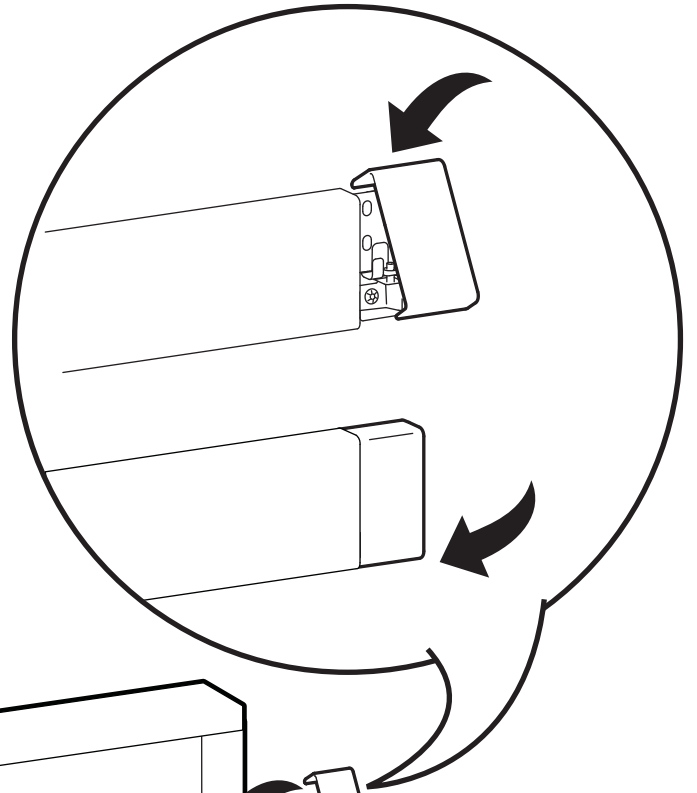
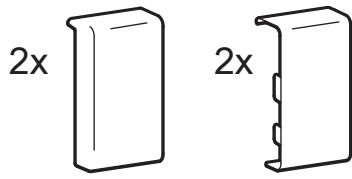

7

Raise the worksurface supports.
Suba los soportes de la superficie de trabajo.
Relevez les supports de la surface de travail.



1

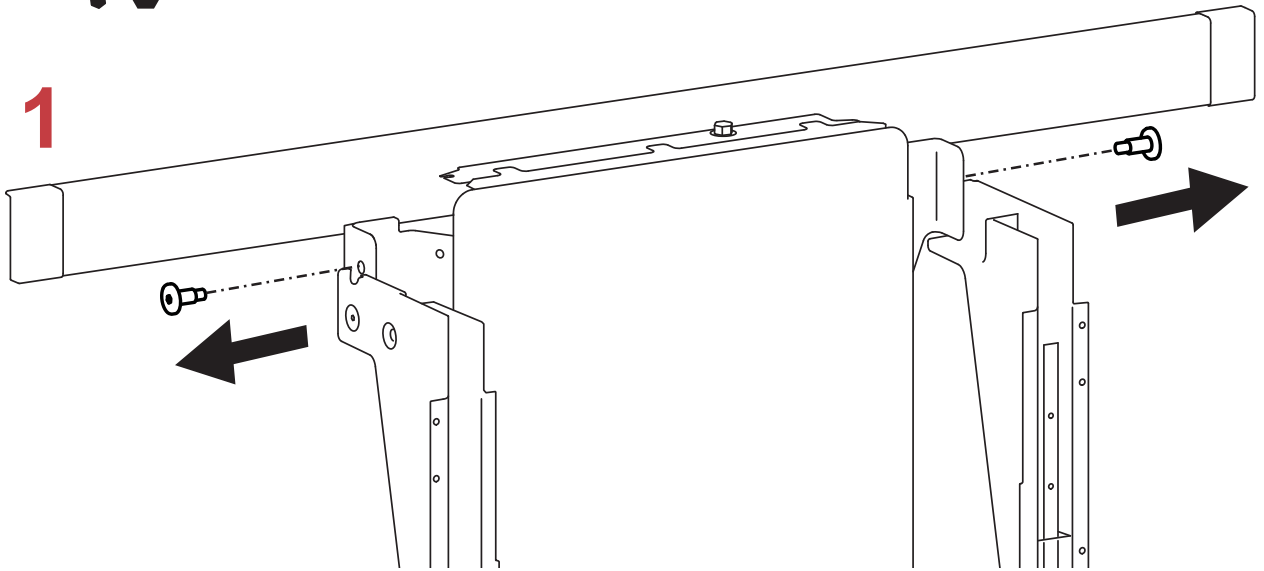

2

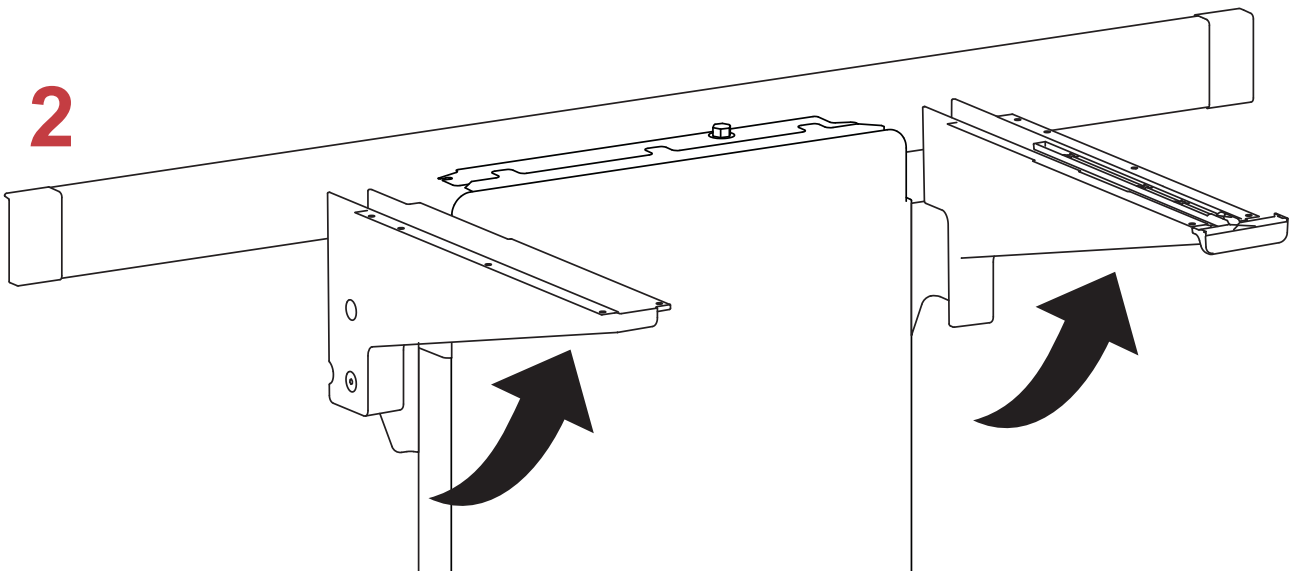

3

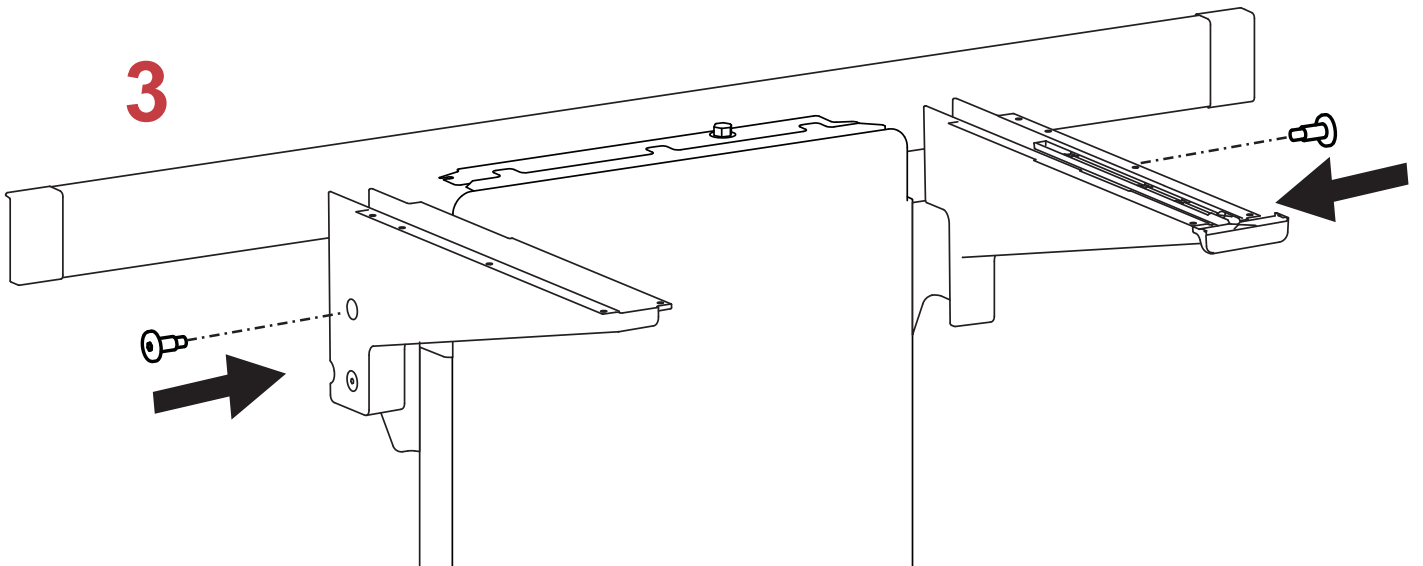

8

1. Attach guide to release handle.
 2. Adjust release handle depth to match the size of your Ergotron JUV worksurface.
1. Fije la guía a la manija de liberación.
 2. Ajuste la profundidad de la manija de liberación para que coincida con el tamaño de su superficie de trabajo JUV de Ergotron.
1. Fixez le guide à la poignée de déverrouillage.
 2. Ajustez la profondeur de la poignée de déverrouillage en fonction de la taille de votre surface de travail Ergotron JUV.

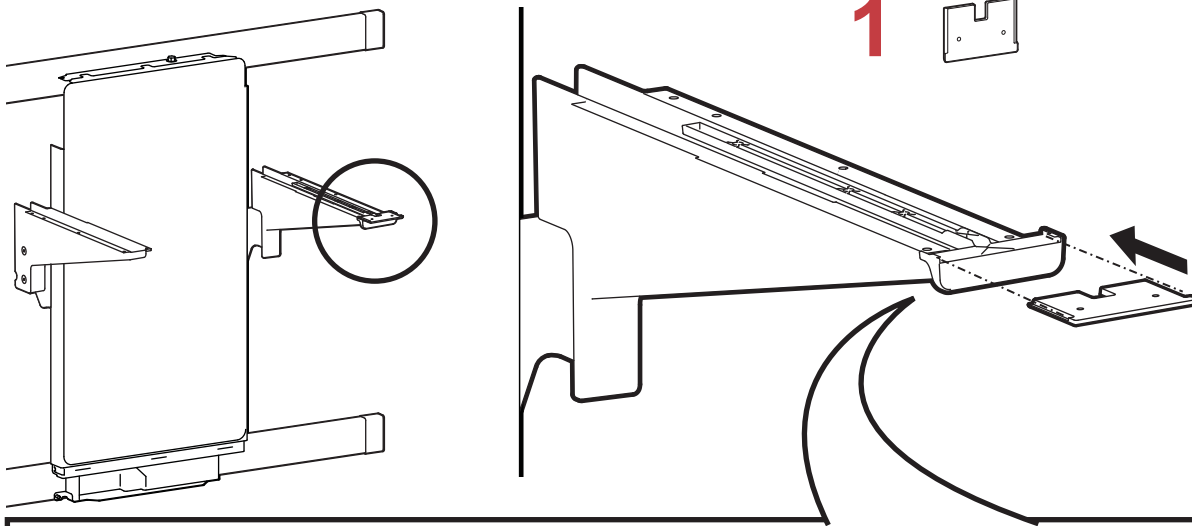

- 2 Remove Pin
Retire el pasador
Retirez la goupille.

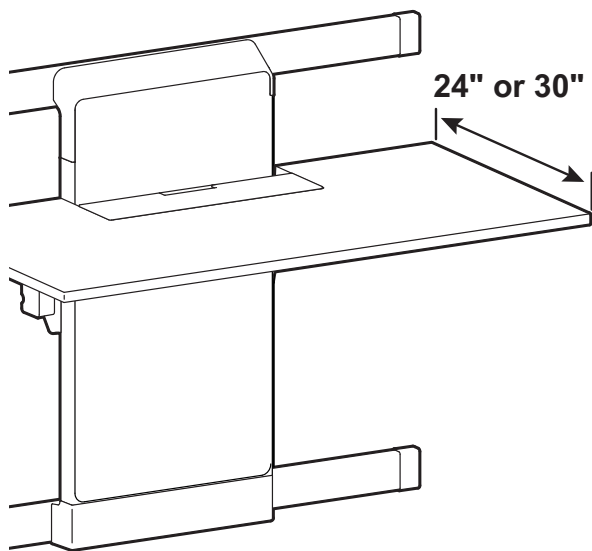

24"

30"

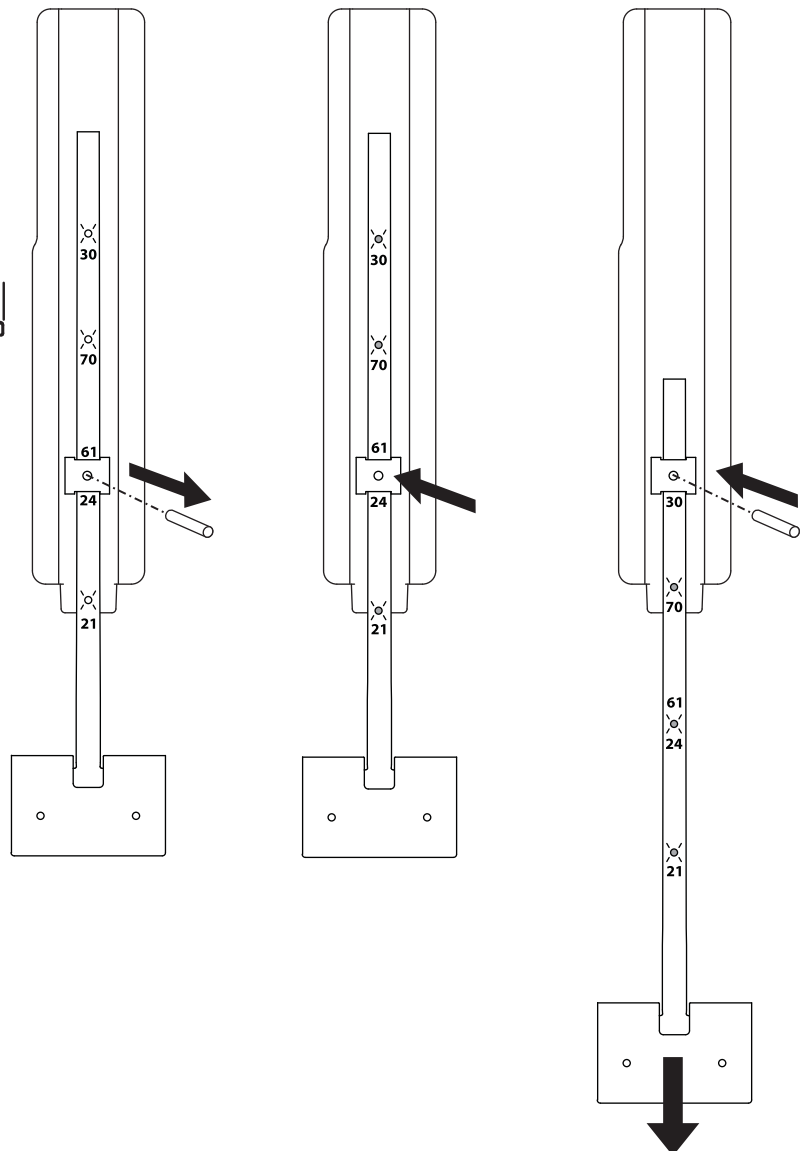

Ergotron JUV Worksurface ordered separately.

La superficie de trabajo JUV de Ergotron se encarga por separado.

Surface de travail Ergotron JUV à commander séparément.

9

Attach plate to worksurface, flip worksurface over and secure plate with brackets.

Fije la placa a la superficie de trabajo, gire la superficie de trabajo y asegure la placa con las abrazaderas.

Montez la plaque sur la surface de travail, retournez la surface de travail et fixez bien la plaque à l'aide de supports.

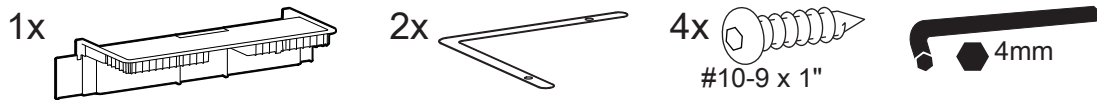

Ergotron JUV Worksurface ordered separately.

La superficie de trabajo JUV de Ergotron se encarga por separado.

Surface de travail Ergotron JUV à commander séparément.

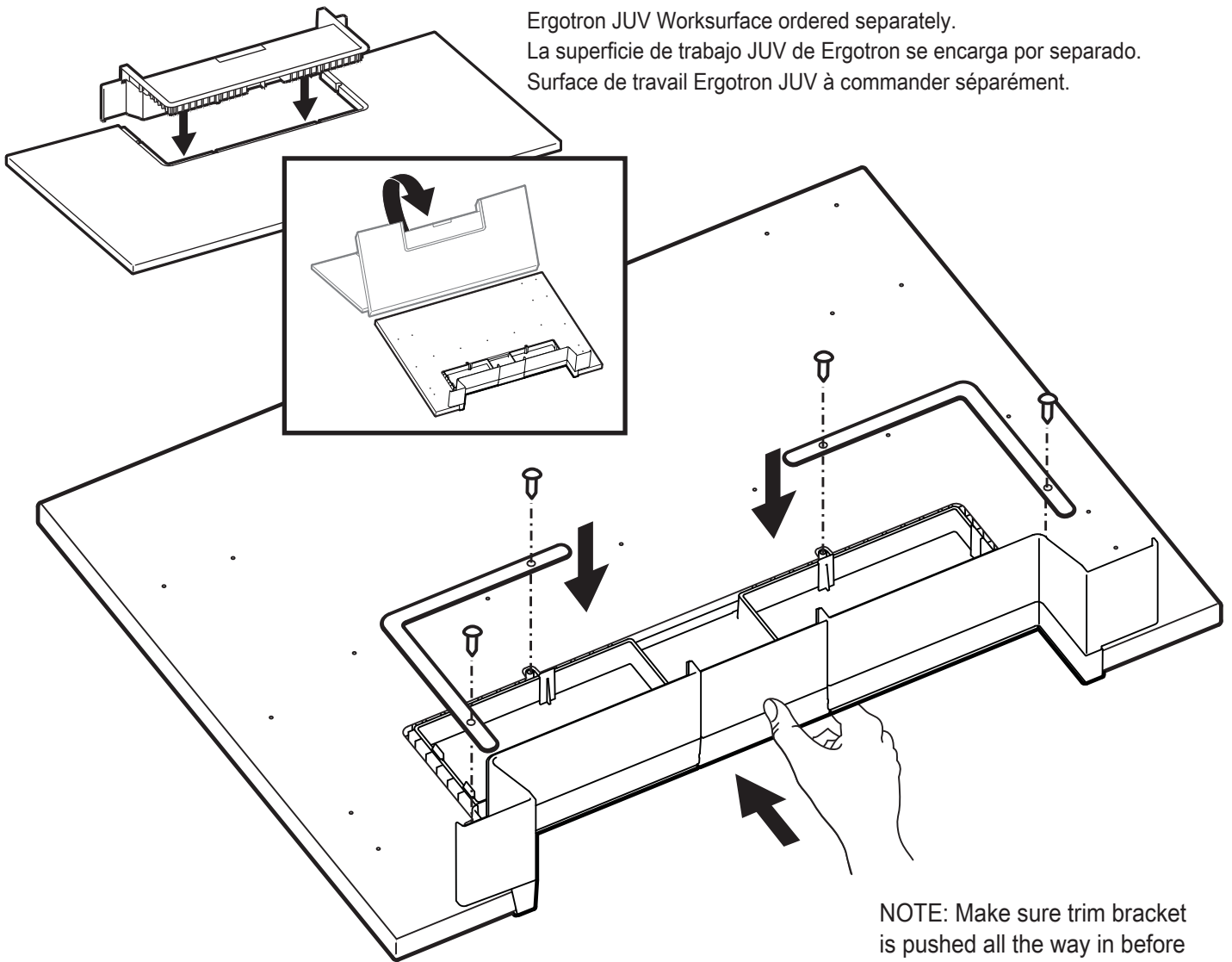

10

If you have the Electrical Kit, follow those instructions now before attaching worksurface.

If you are installing a non-powered unit, please continue with these instructions.

Si tiene el kit eléctrico, siga estas instrucciones ahora.

Si va a instalar una unidad sin alimentación eléctrica, continúe con estas instrucciones.

Si vous avez le kit électrique, suivez ces instructions maintenant.

Si vous installez une unité non alimentée, veuillez continuer avec ces instructions.

11

Attach your Ergotron JUV Worksurface (ordered separately).
Fije su superficie de trabajo JUV de Ergotron (se encarga por separado).
Fixez votre surface de travail Ergotron JUV (à commander séparément).

10x 
#10-9 x 1"

 4mm

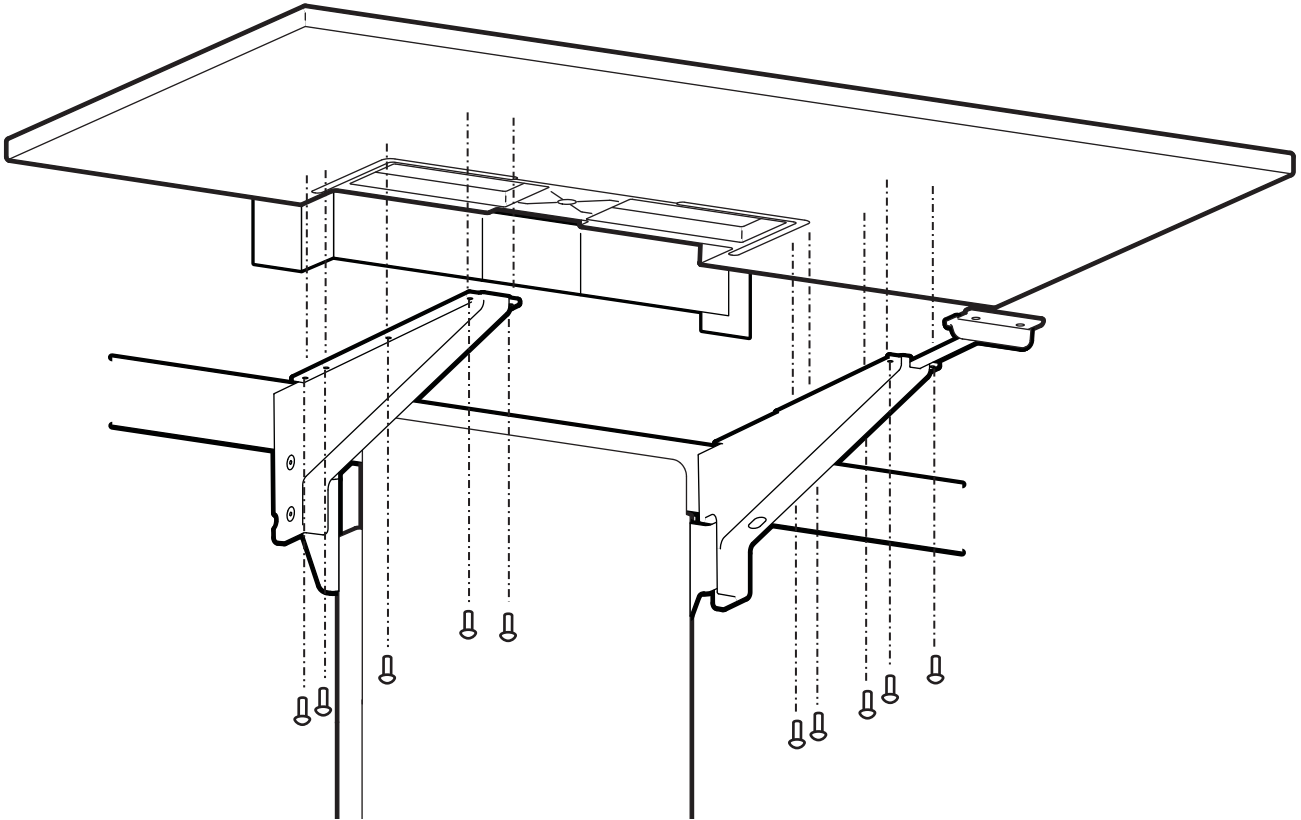

12

Secure guide to worksurface.
Asegure la guía a la superficie de trabajo.
Fixez bien le guide à la surface de travail.

2x 
ST4.2 x 13mm

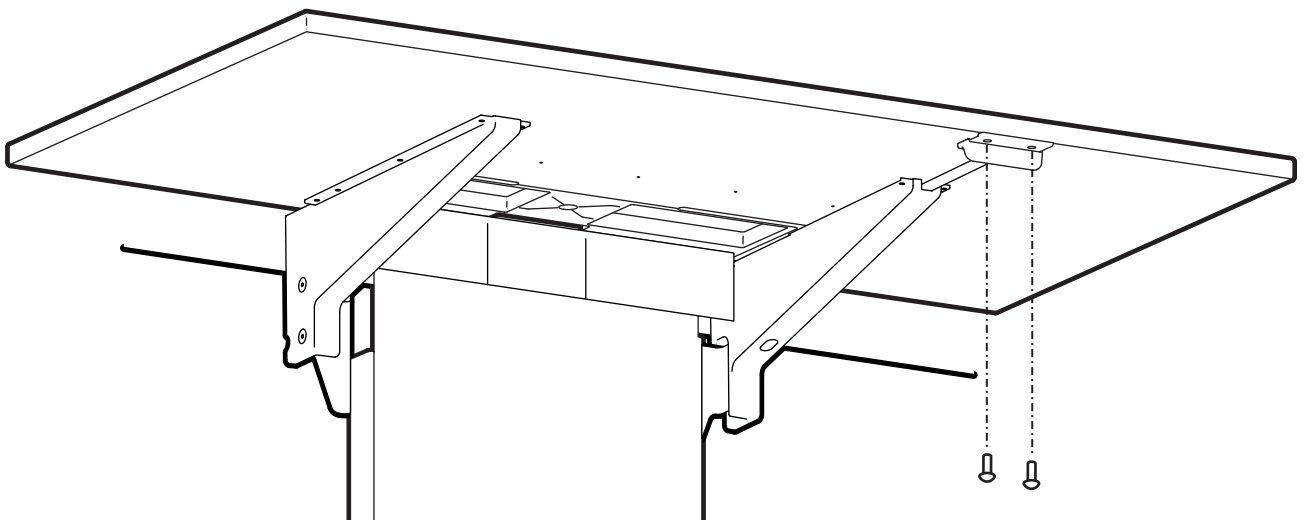

13

Attach clips at favorite worksurface heights for quick reference when moving from sitting to standing.

Fije los clips a la altura favorita de la superficie de trabajo para obtener una referencia rápida al pasar de estar sentado a estar de pie.

Fixez des clips aux hauteurs de surface de travail préférées afin de passer plus rapidement de la position assise à la position debout.

2x 

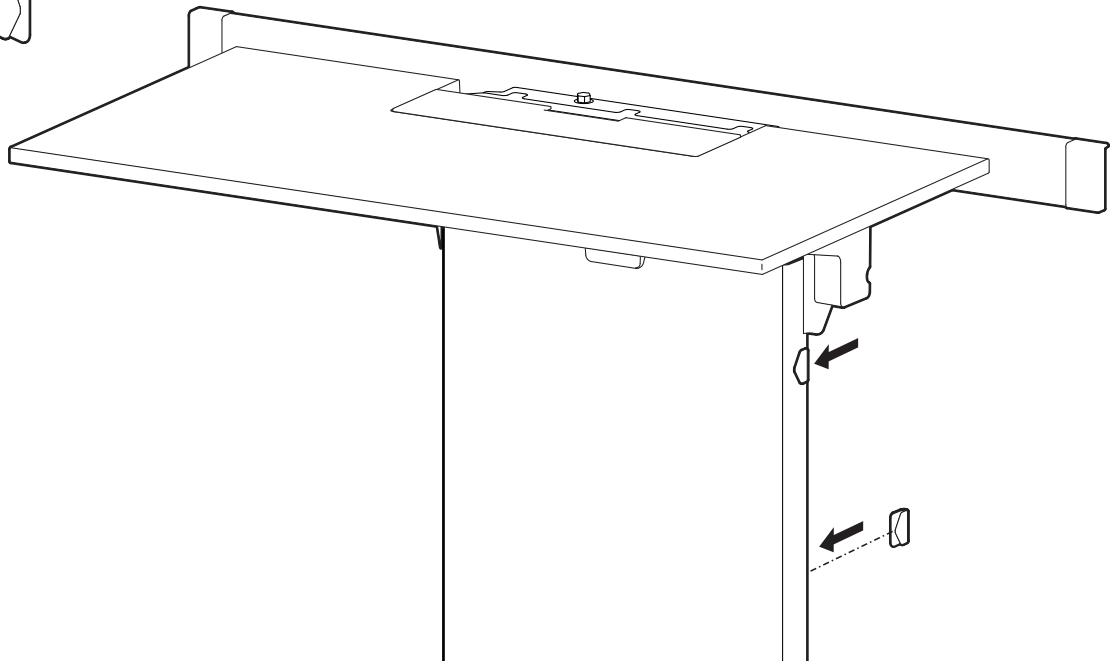

14

Attach bottom cover.

Fije la cubierta inferior.

Fixez la protection inférieure.

2x  M4 x 8mm
Plastite

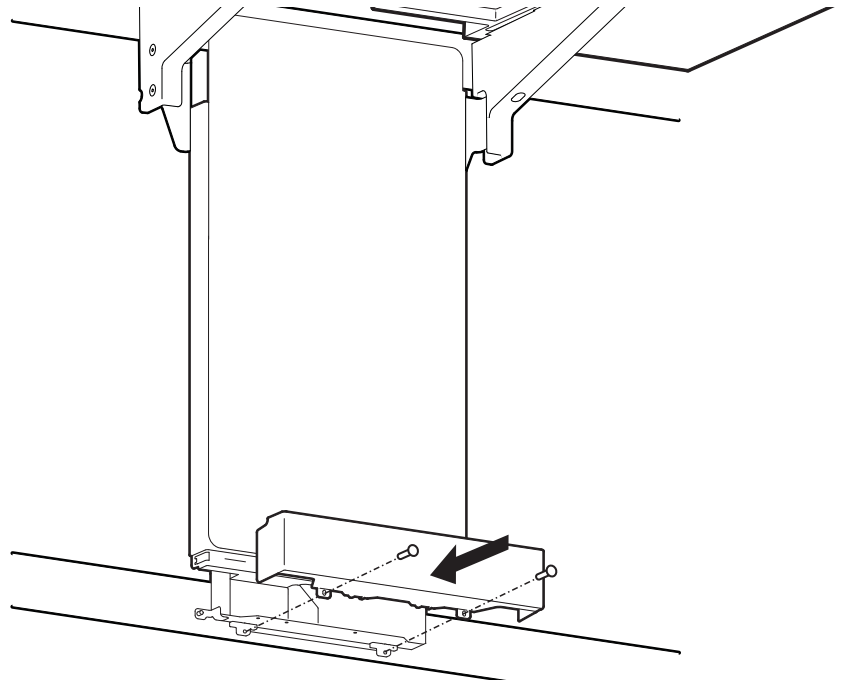

15



Adjustment Step Etapa de ajuste Étape de réglage

1

Lift – Up and down
Elevación (arriba y abajo)
Ajustement en hauteur : bas et haut

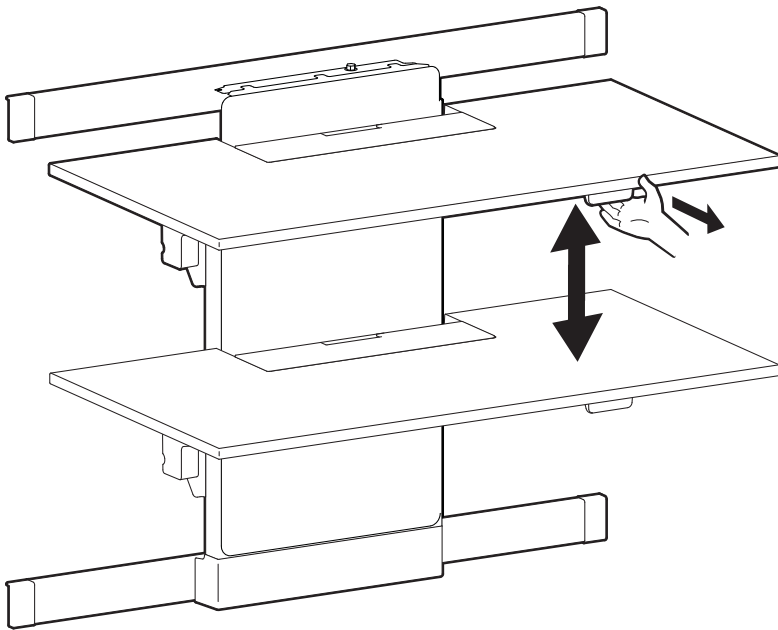

Important! You will need to adjust this product after installation is complete. Make sure all your equipment is properly installed on the product before attempting adjustments. This product should move smoothly and easily through the full range of motion and stay where you set it. If movements are too easy or difficult or if product does not stay in desired positions, follow the adjustment instructions to create smooth and easy movements. Depending on your product and the adjustment, it may take many turns to notice a difference. Any time equipment is added or removed from this product, resulting in a change in the weight of the mounted load, you should repeat these adjustment steps to ensure safe and optimum operation.

¡Importante! Tendrá que ajustar este producto una vez que haya terminado la instalación. Asegúrese de que todo su equipo esté instalado correctamente en el producto antes de intentar llevar a cabo algún ajuste. Este producto debe poder moverse de manera fácil y firme dentro de la amplitud de movimiento permitida y mantenerse donde usted lo fije. Si los movimientos son demasiado fáciles o difíciles o si el producto no se mantiene en las posiciones deseadas, siga las instrucciones de ajuste para conseguir movimientos suaves y fáciles. Dependiendo del producto y el ajuste, es posible que deba hacer muchos intentos hasta poder observar la diferencia. Cada vez que añada o retire equipos de este producto y que produzca un cambio en el peso de la carga, debe repetir estos pasos de ajuste para garantizar un funcionamiento seguro y óptimo.

Important ! Vous devez ajuster le produit une fois l'installation terminée. Assurez-vous que l'équipement est correctement installé sur le produit avant de procéder aux ajustements. Ce produit doit pouvoir être déplacé sans difficulté sur toute la plage de mouvement et rester immobilisé à l'endroit où il est réglé. Si le mouvement est trop facile ou trop difficile, ou si le produit ne reste pas dans les positions souhaitées, procédez selon les instructions de réglage pour harmoniser les mouvements. En fonction de votre produit et du réglage, plusieurs tours peuvent s'avérer nécessaire pour remarquer la différence. Chaque fois qu'une pièce d'équipement est ajoutée ou retirée de ce produit, affectant en conséquence le poids de la charge montée, vous devez répéter ces étapes de réglage afin de garantir une utilisation sécurisée et optimale du produit.

2

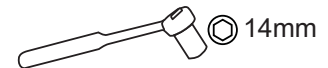

+ **LB kg**
Increase Lift Strength
If the mounted weight is too heavy or this product does not stay up when raised, then you'll need to increase Lift Strength:

- **LB kg**
Decrease Lift Strength
If the mounted weight is too light or this product does not stay down when lowered, then you'll need to decrease Lift Strength:

+ **LB kg**
Aumentar la fuerza de elevación
Si el peso colocado es demasiado o si el producto no se mantiene arriba cuando se eleva, debe aumentar la fuerza de elevación:

- **LB kg**
Reducir la fuerza de elevación
Si el peso colocado es muy poco o si el producto no se mantiene abajo cuando se baja, tendrá que disminuir la fuerza de elevación:

+ **LB kg**
Augmenter la force de levage
Si le poids installé est trop lourd ou si le produit ne reste pas en place une fois soulevé, vous devez augmenter la force de levage :

- **LB kg**
Réduire la force de levage
Si le poids installé est trop faible ou si le produit ne reste pas en place une fois abaissé, vous devez réduire la force de levage :

16

Attach top cover.
Fije la cubierta superior.
Fixez la protection supérieure.

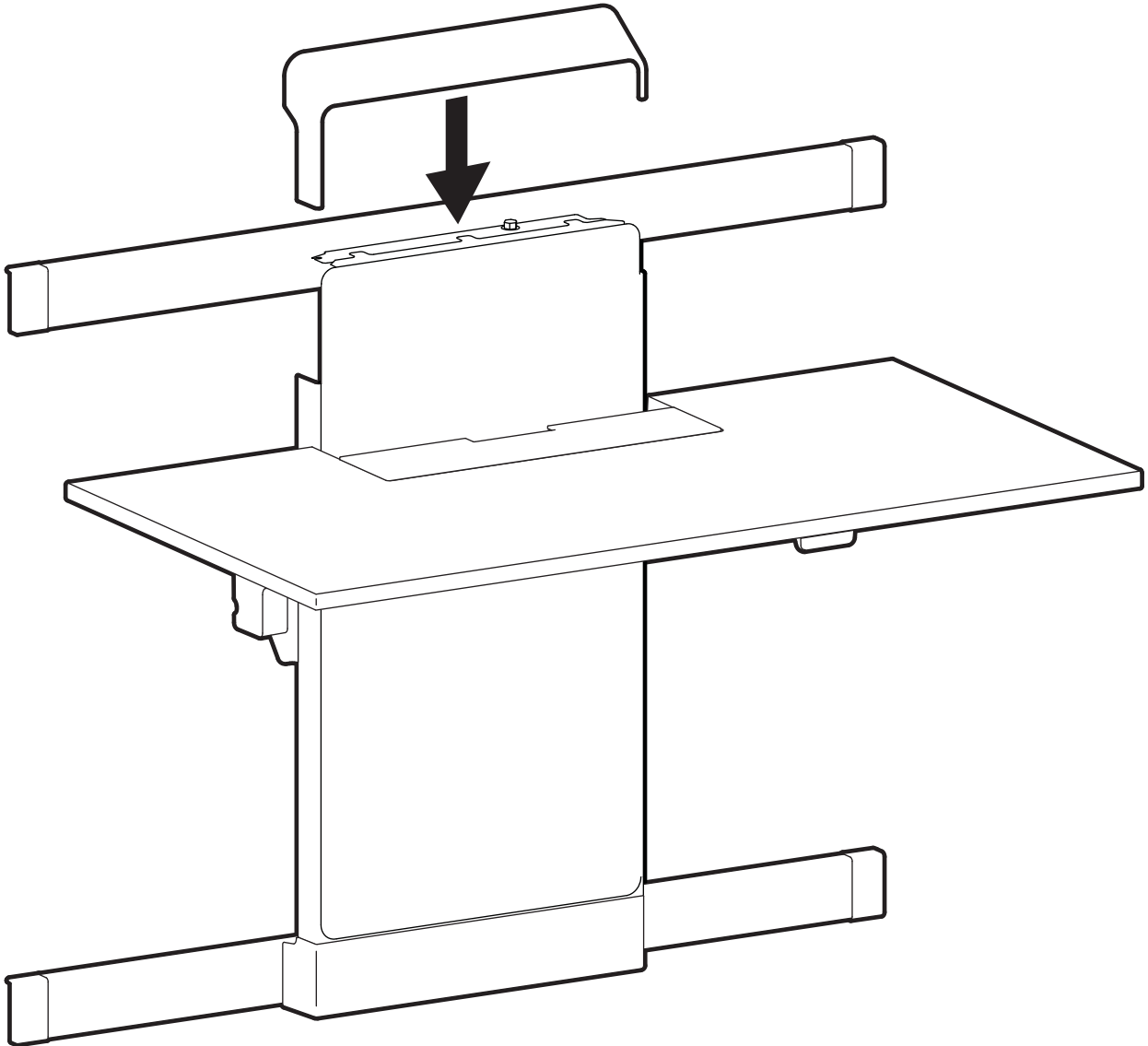

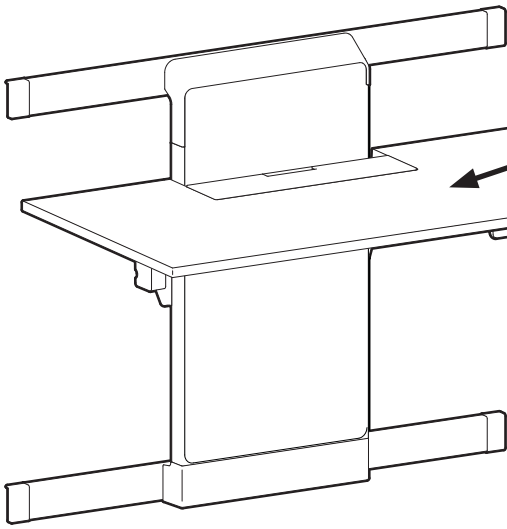

≤ 40 lbs. (18.14 kg)



CAUTION: DO NOT EXCEED MAXIMUM LISTED WEIGHT CAPACITY. SERIOUS INJURY OR PROPERTY DAMAGE MAY OCCUR!

PRECAUCIÓN: NO SUPERE LA CAPACIDAD DE PESO MÁXIMA INDICADA. PODRÍA OCURRIR DAÑOS MATERIALES GRAVES O LESIONES FÍSICAS.

ATTENTION : NE PAS DÉPASSER LA CAPACITÉ NOMINALE MAXIMALE MENTIONNÉE. DE SÉRIEUSES BLESSURES OU DES DOMMAGES MATÉRIELS POURRAIENT SE PRODUIRE !

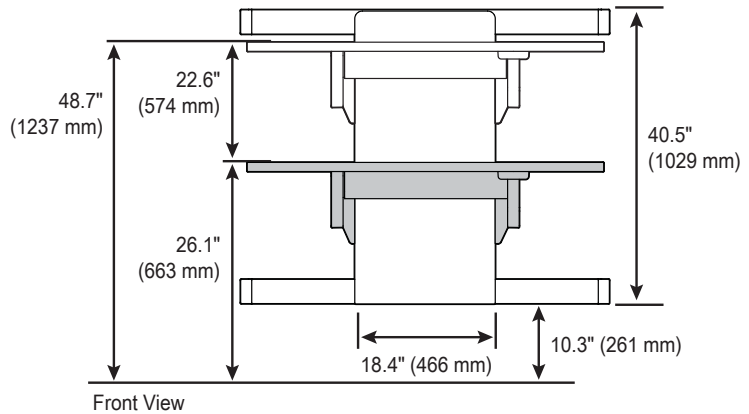
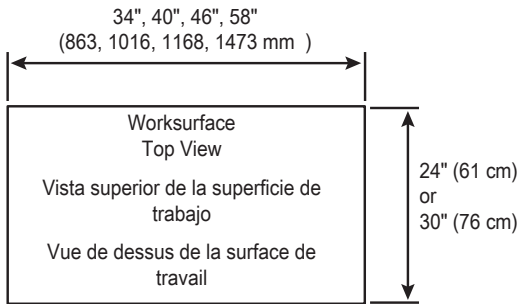

For Warranty visit: www.ergotron.com/warranty

For Service visit: www.ergotron.com

For local customer care phone numbers visit: <http://contact.ergotron.com>

NOTE: When contacting customer service, reference the serial number.

Para Garantía, visite: www.ergotron.com/warranty

Para servicio, visite: www.ergotron.com

Para conocer los números telefónicos locales de atención al cliente, visite: <http://contact.ergotron.com>

NOTA: Cuando se ponga en contacto con el servicio de atención al cliente, haga referencia al número de serie.

Pour la garantie, visitez: www.ergotron.com/warranty

Pour le service client, visitez: www.ergotron.com

Pour les numéros de téléphone du service client local, visitez : <http://contact.ergotron.com>

REMARQUE : Lorsque vous contactez le service à la clientèle, veuillez donner le numéro de série.

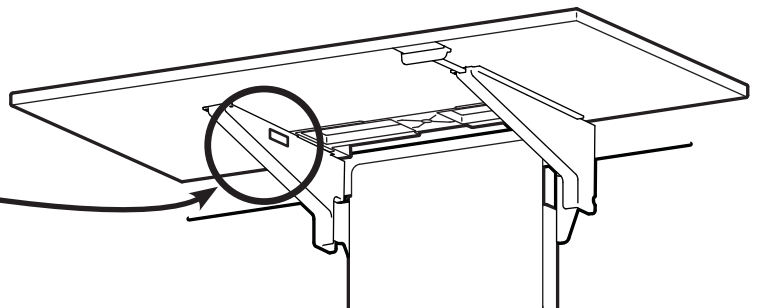

ergotron®

www.ergotron.com | USA: 1-800-888-8458

© 2018 Ergotron, Inc. All rights reserved. JUV™ and Constant Force are registered trademarks of Ergotron, Inc.

While Ergotron, Inc. makes every effort to provide accurate and complete information on the installation and use of its products, it will not be held liable for any editorial errors or omissions (including those made in the process of translation from English to another language), or for incidental, special or consequential damages of any nature resulting from furnishing this instruction and performance of equipment in connection with this instruction. Ergotron, Inc. reserves the right to make changes in the product design and/or product documentation without notification to its users. For the most current product information, or to know if this document is available in languages other than those herein, please contact Ergotron. No part of this publication may be reproduced, stored in a retrieval system, or transmitted in any form or by any means, electronic, mechanical, photocopying, recording or otherwise without the prior written consent of Ergotron, Inc., 1181 Trapp Road, Eagan, Minnesota, 55121, USA Patents Pending and Patented U.S. & Foreign. Ergotron is a registered trademark of Ergotron, Inc.