

## e-Spinner 3

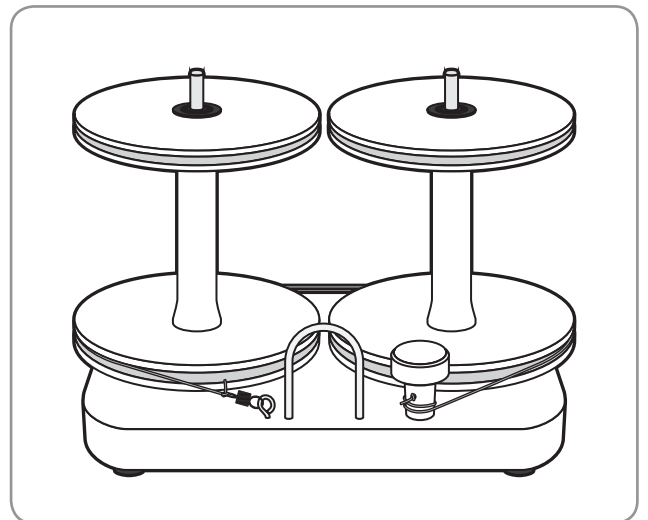
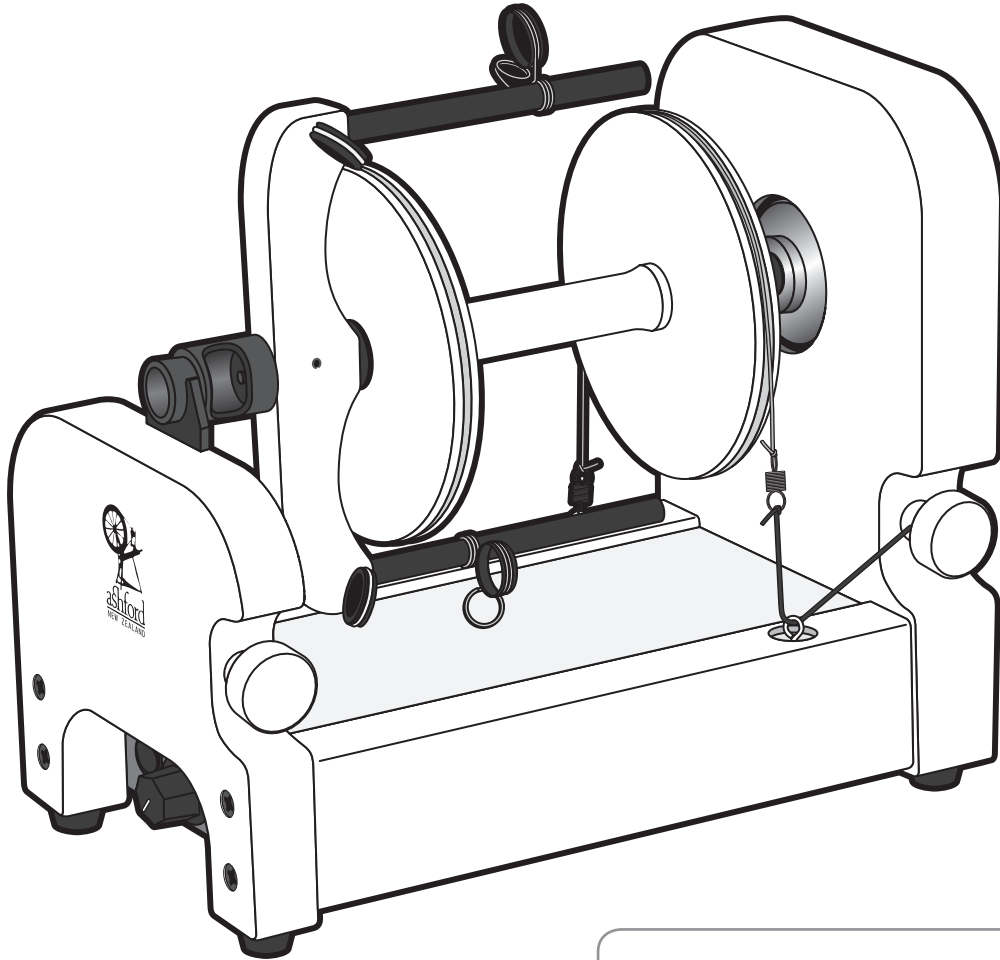

ESP151117V2

# ASSEMBLY INSTRUCTIONS FOR THE ASHFORD e-Spinner 3

Before commencing, please read these instructions completely, identify the parts and note the assembly sequence.

## Finish

Your e-Spinner 3 has been lacquered prior to assembly. If desired Ashford Wax Finish may be applied to further enhance its appearance.

## Tools Required



## Assembly

**1.** Squeeze and slide the stainless-steel yarn guides onto the flyer arms.  
Note the nylon eyes are on the same side.  
**NOTE:** when spinning at higher RPM it may be necessary to squeeze & rotate whichever yarn guide isn't being used to achieve perfect balance.

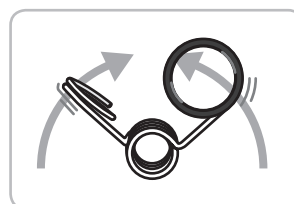

**2.** Cut the nylon brake band into 2 pieces, 35 cm for the brake band and 65 cm (14" and 25 1/2") for the lazy kate. Tie the 35 cm (14") piece to one of the springs attached to a screw eye. Then tie the spring to the brake band allowing approx. 270mm – 280mm (10 1/2 – 11") between the springs. See illustration. Thread the tail of the nylon brake band down the inside of the spring & trim off surplus.

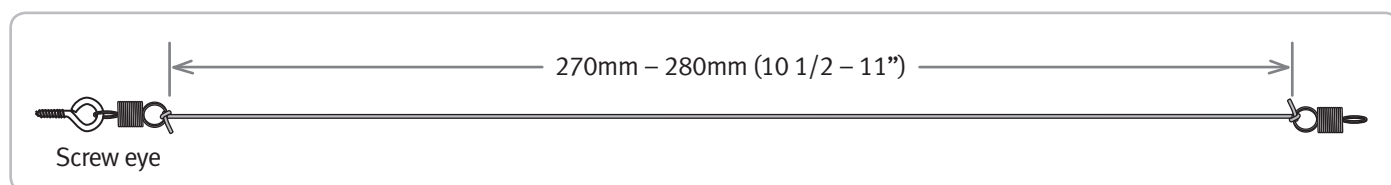
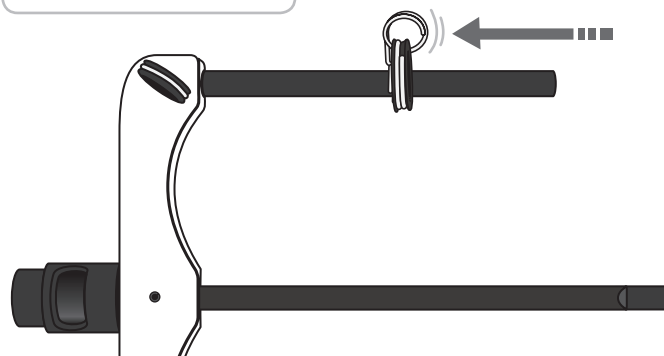

**3.** Thread the screw eye with the tension spring and brake band attached, into the pilot hole in the left-hand side.

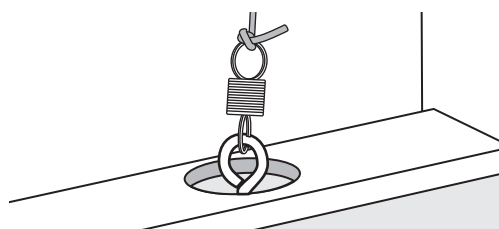

**4.** Thread the screw eye into the pilot hole in the right-hand side.

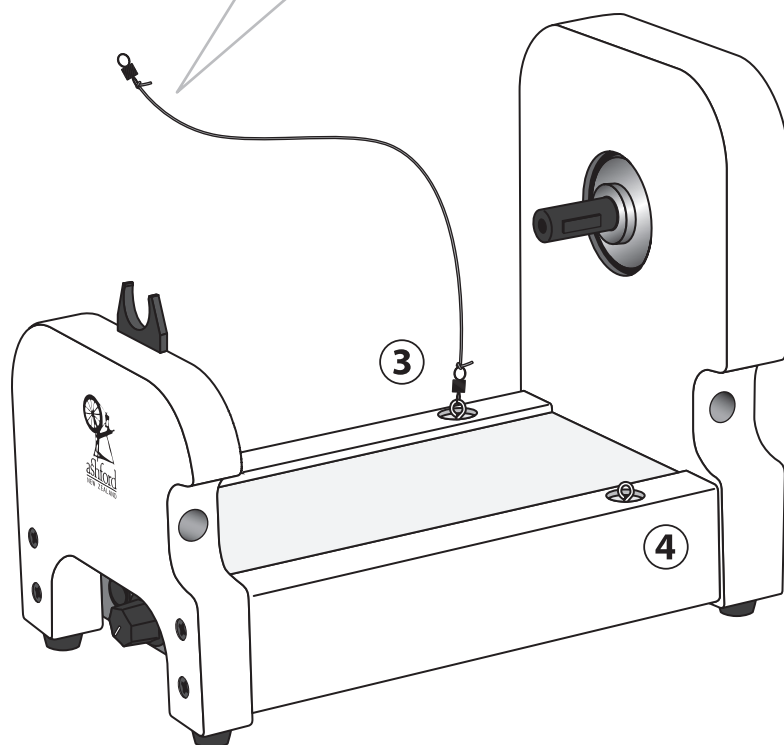
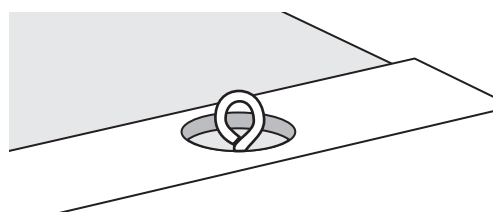

**5.** Apply a drop of oil to the flyer spindle and slide a bobbin on.

**6.** Apply a drop of oil to the end of the flyer shaft and feed it into the flexible motor drive. Note the flat on the shaft aligns with the raised line on the flexible drive. Snap the flyer down into the front flyer bearing. Apply a drop of oil to lubricate this bearing. Don't over oil.

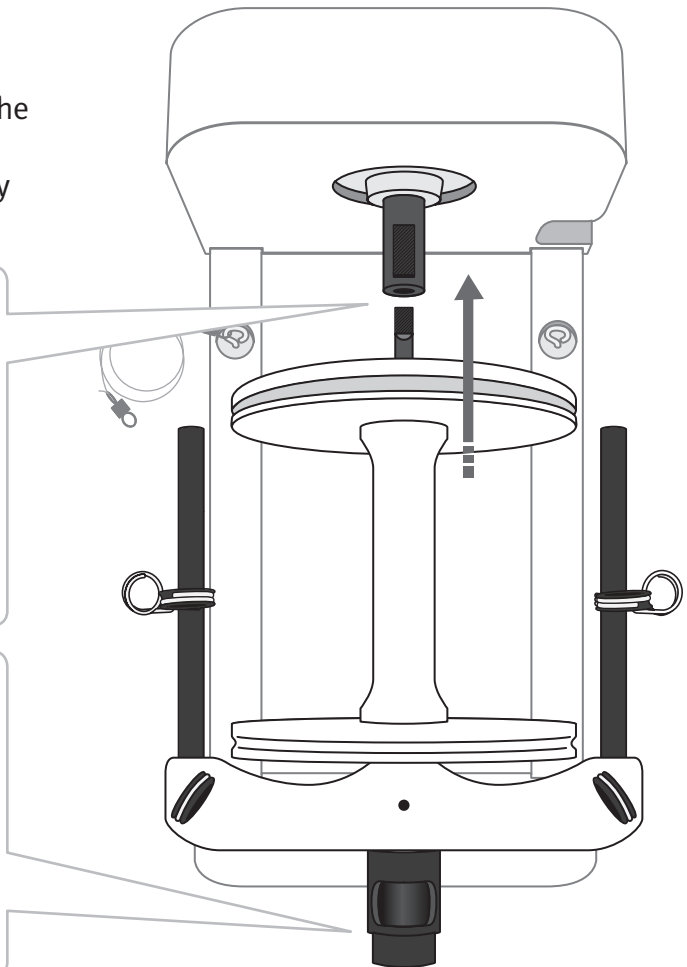
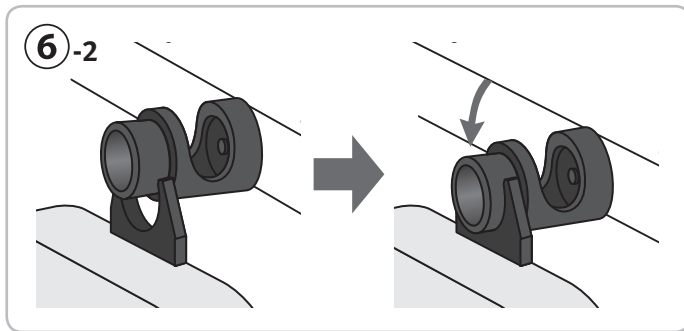
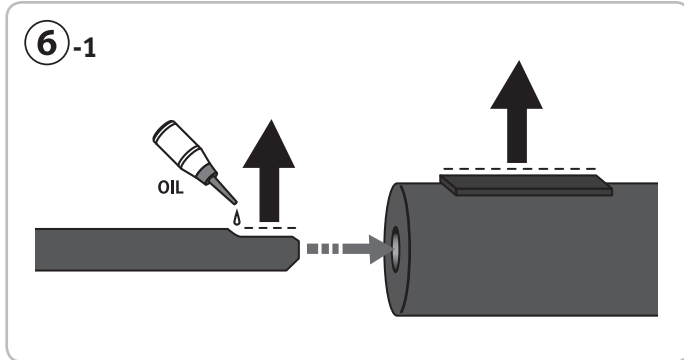

**7.** Tie one end of the black waxed thread to the end of the spring, thread through the screw eye and tension knob and tie a knot.

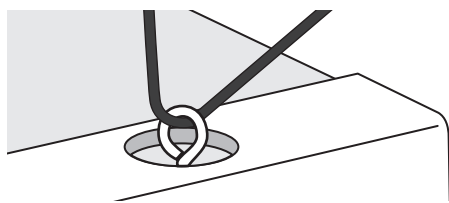

**8.** Place the nylon brake band around the bobbin whorl, place the tension knob in the tapered hole and tighten until the springs just start to extend. This is the normal amount of brake band tension required. Do not extend the springs more than 1 1/2 times their own length.

**9.** Locate the threading hook into the tapered hole in the front.

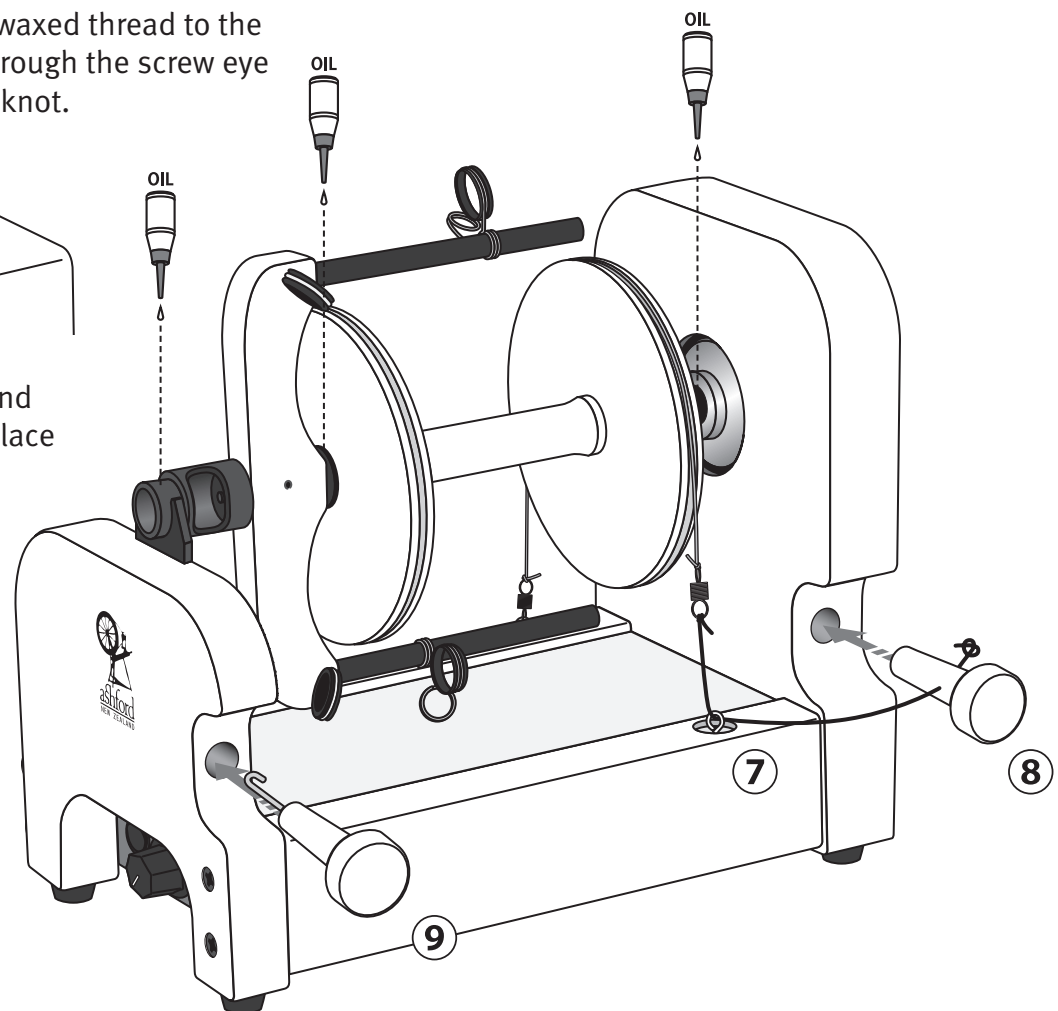

# Lazy kate

1. Tie the 65 cm (25 ½") piece of nylon brake band to the other spring attached to a screw eye. Thread the tail of the nylon brake band down the inside of the spring & trim off surplus.
  2. Thread the screw eye with the spring and brake band attached into the pilot hole in the lazy kate base.
  3. Gently tap the 2 bobbin pins into the holes in the lazy kate base.
  4. Gently squeeze the ends of the yarn guide together and push it into the 2 holes in the lazy kate base.
  5. Position the 2 bobbins onto the bobbin pins.
  6. Thread the nylon brake band through the hole in the tension knob and tie a knot.
  7. Place the tension knob in the tapered hole, wrap the nylon brake band around the 2 bobbin whorls and tighten until the spring just starts to extend. This is the normal amount of tension required. Do not extend the spring more than 1 ½ times its own length.
- When plying, feed the 2 ends of your yarn through the yarn guide.

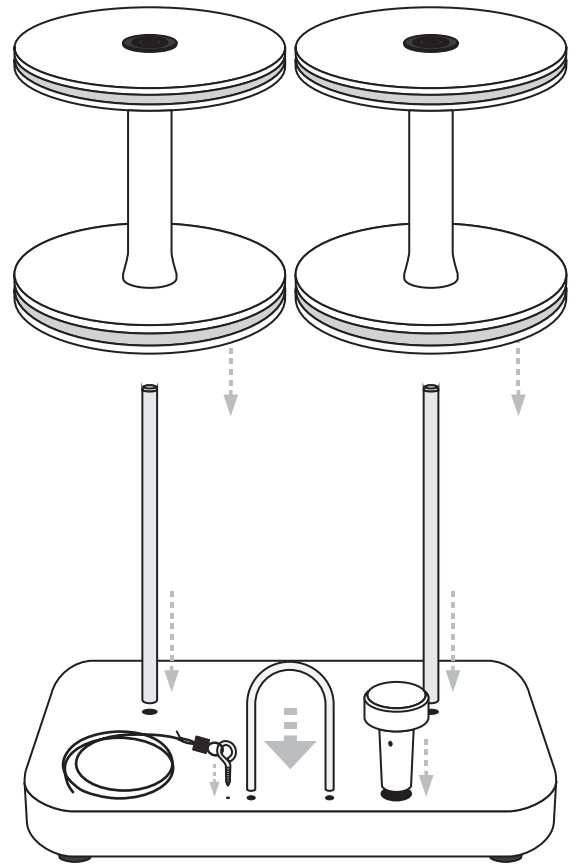

## Controls

1. SPIN/PLY (Clockwise/Anticlockwise): SPIN is for spinning, PLY is for plying. Do not reverse the direction without stopping the motor with the ON/OFF switch.
2. SPEED: Start on SLOW and turn the dial clockwise to gradually increase the speed until the correct RPM is achieved.
3. ON/OFF: The e-Spinner 3 is fitted with a soft start which results in the motor taking 2 – 3 seconds to reach the desired speed. This prevents the yarn being jerked out of your hands when starting. Always switch the e-Spinner 3 OFF rather than using the speed control when you want to stop. Check the red LED light is off before you leave your e-Spinner 3.

### Foot Switch

If you would like to START and STOP your e-Spinner 3 with the foot switch only, insert the foot switch plug into the FOOT SWITCH hole in the rear of the e-Spinner 3.

There are 2 operating modes.

- a) Turn the ON/OFF switch to ON. Lightly tap the foot switch to turn the e-Spinner 3 ON and lightly tap again to turn the e-Spinner 3 OFF.
- b) Lightly put your foot on the foot switch and turn the power ON. The e-Spinner 3 will operate only while your foot is on the foot switch. Lift your foot and the e-Spinner will stop.

**Note:** Ensure the e-Spinner 3 is switched off before removing the foot switch plug.

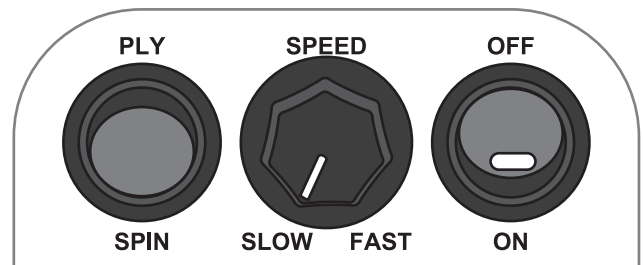

### LED Light

The Red LED light indicates the status of your e-Spinner.

#### Constant on.

The e-Spinner 3 is running normally.

#### Flashing short on/short off.

The e-Spinner 3 is on standby. The speed is set to ZERO or the foot switch is OFF.

#### Flashing long on/short off.

The power pack is under load. This is OK and you can't harm the e-Spinner 3. However, we recommend you either reduce the brake band tension, reduce speed or apply a drop of oil to the flyer and bobbin bearings until the flashing stops.

---

## Power Pack

---

Your e-Spinner 3 12v power pack is supplied with interchangeable wall plugs for Australia/New Zealand, Canada/Japan/USA, Europe/Scandinavia and the UK.

**1.** To change the wall plug to suit your country, push the locking pin down and forward and slide the wall plug off. Slide the correct wall plug onto the power supply until it is locked securely in position.

**2.** Check the ON/OFF switch is OFF and the SPEED dial on SLOW. Then insert the power cord into the INPUT hole in the rear of the e-Spinner 3, insert the power pack into a main power point and switch on.

**Note:** The power pack will accept an input from 100-240 volts.

## Spinning

---

**IMPORTANT:** Make sure the flyer has snapped fully into the bearing before starting spinning.

- Tie a piece of yarn, called a leader, about 1metre (1 yard) long to the bobbin, loop it through the sliding flyer hook nylon eye on the **right-hand side of the flyer**, through the nylon eye in the flyer base and out through the orifice.
- Have your prepared fibres ready to spin.
- Adjust the tension knob until both springs are only just beginning to stretch.
- Check the SPIN/PLY switch is on SPIN (down) and the SPEED control is on SLOW. Switch the ON/OFF switch to ON. Gradually turn the SPEED control clockwise until the flyer starts to turn slowly.
- Allow the leader to start feeding in and commence drafting the prepared fibres onto it.
- Adjust the SPEED control and tension knob to achieve a comfortable speed and take up. Use the ON/OFF switch

## Plying

---

- Thread the leader through the sliding flyer hook nylon eye on the **left-hand side of the flyer**, through the nylon eye in the flyer base and out through the orifice. Locate your 2 bobbins of spun yarn onto the lazy kate pins, thread the 2 strands of yarn through the yarn guide and tie them to the leader.
- Check the SPIN/PLY switch is on PLY (up) and the SPEED control is on SLOW. Switch the ON/OFF switch to ON. Gradually turn the SPEED control clockwise until the flyer starts to turn slowly.
- Allow the leader and your spun yarn to start feeding in. Use the least amount of brake band tension possible.

\* For further plying information refer to "The Ashford Book of Hand Spinning" by Jo Reeve, a 116-page book full of ideas and inspirations for spinners.

## Lubrication

---

- We recommend Ashford Spinning Wheel Oil be regularly applied to the front flyer and bobbin bearings.
- The bobbin and flyer must revolve freely and independently of each other.
- A drop of Vaseline or oil may be applied to the flexible motor drive to make bobbin changing easier and to minimize noise.
- The ball bearings in the motors may be noisy for the first 5-10 minutes as they "run-in" and the grease is dissipated evenly.

- or foot switch (rather than the speed control) to stop the motor when moving the position of the yarn guide. This will ensure you recommence at the same speed.
- To change the bobbin, turn the motor off using the ON/OFF switch or foot switch. Use 2 hands, one either side of the front bearing to lift and snap the flyer out of the bearing. Pull the flyer towards you out of the flexible drive.
- Change the bobbin, then hook the brake band back over the flyer whorl, slide the flyer back into the flexible drive and snap the flyer down into the front bearing.

\* For further spinning information refer to "The Ashford Book of Hand Spinning" by Jo Reeve, a 116 page book full of ideas and inspirations for spinners or visit our website [www.ashford.co.nz](http://www.ashford.co.nz)

### Orifice Reducer Bush

- The nylon bush may be inserted into the flyer orifice to reduce the diameter from 15mm (5/8") to 10mm (3/8").
- This is beneficial when spinning finer yarns as it will help prevent the yarn vibrating. By drafting the yarn at about a 45 degree angle to the orifice the vibration will almost be eliminated.
- When spinning or plying thicker yarns, remove the bush.

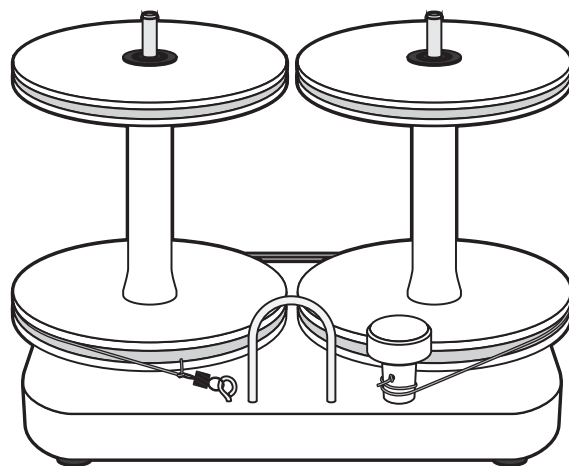
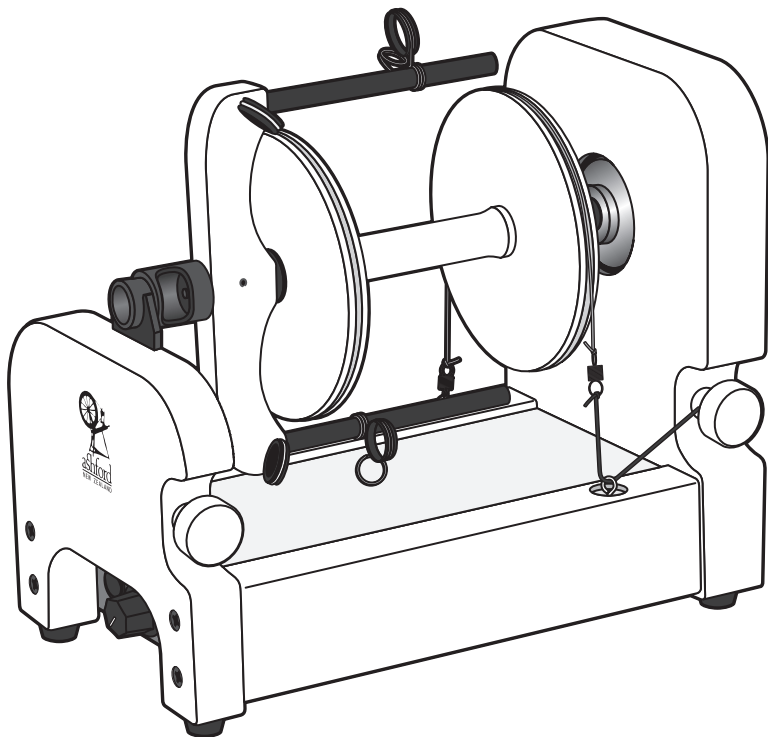

## Safety

1. Take care to ensure children and pets are always well clear of the e-Spinner when starting or while it is in use.
2. Always unplug the power pack from the wall when not in use.
3. Never leave the e-Spinner 3 without switching it OFF at the ON/OFF switch.
4. Ensure the e-Spinner 3 is switched off before removing the foot switch plug.
5. Do not use your e-Spinner 3 in damp or wet conditions.
6. Never open the electronic compartment without first disconnecting it from the power supply.

## Accessories - Available from your local Ashford Dealer.

### 12V cigarette cord

so you can spin away from home in your car, caravan, RV, boat or using a battery pack.



### Bobbins

Ashford Jumbo single drive bobbins.



## More Information



### How-to videos on You Tube

Watch our how-to videos on You Tube.  
[www.youtube.com/user/AshfordHandicrafts](http://www.youtube.com/user/AshfordHandicrafts)



### Facebook

Join us on facebook.  
[www.facebook.com/ashford.wheels.loom](http://www.facebook.com/ashford.wheels.loom)



### The Wheel Magazine

Ashford's annual fibrecraft magazine. Spinning, weaving, felting, dyeing and knitting projects, patterns and articles from around the world. To receive the premium version delivered to you, subscribe at: [www.ashford.co.nz/subscribe](http://www.ashford.co.nz/subscribe)

**ashford**  
WHEELS & LOOMS

Ashford Handicrafts Limited  
Factory and Showroom: 415 West Street  
PO Box 474, Ashburton 7700 New Zealand  
Telephone 64 3 308 9087 Facsimile 64 3 308 8664  
Email: [sales@ashford.co.nz](mailto:sales@ashford.co.nz) Internet: [www.ashford.co.nz](http://www.ashford.co.nz)