

ASHFORD DRUM CARDERS Coarse, Fine, Super Fine and Wide

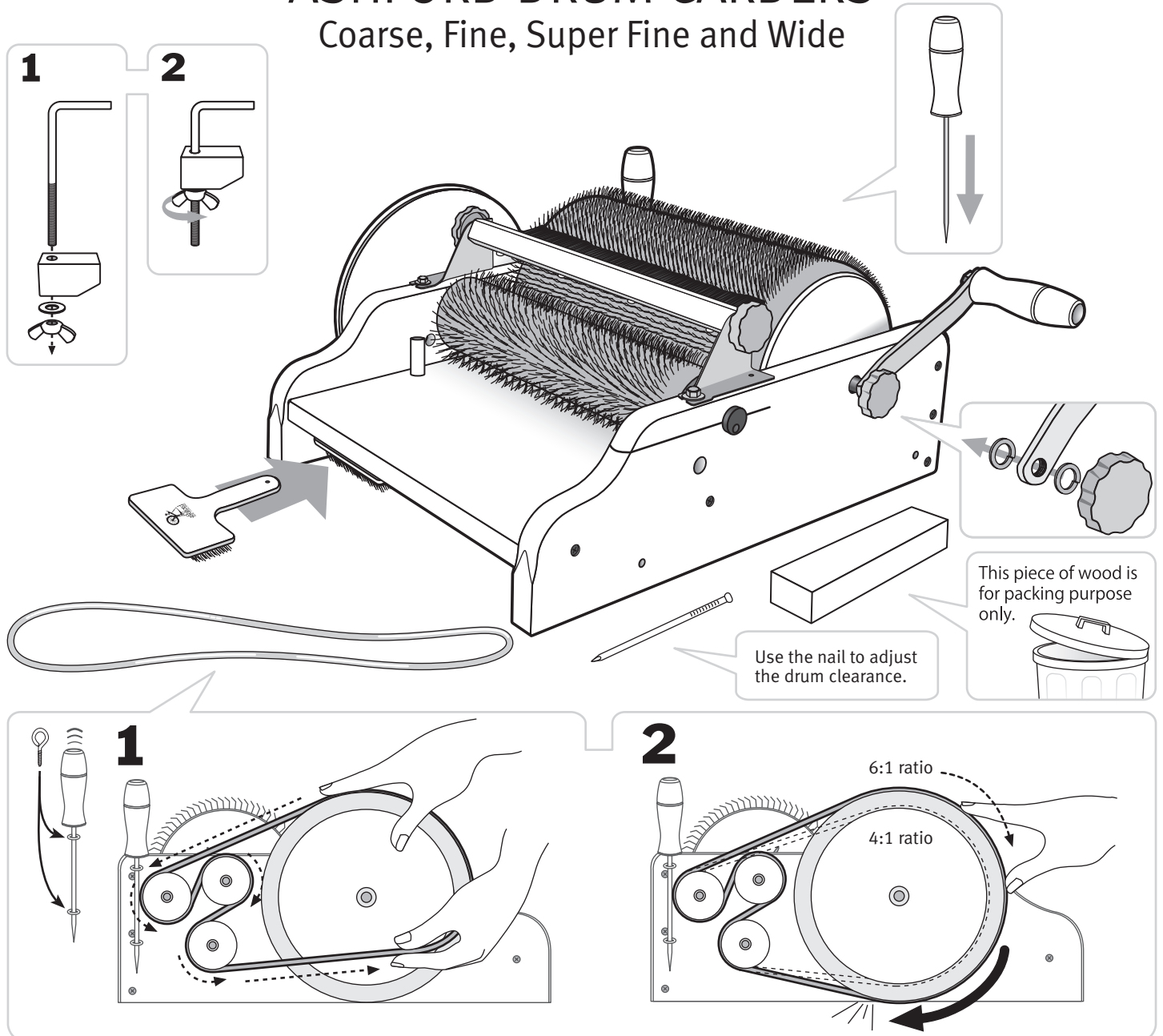

The Ashford Drum Carder

Prepare batts quickly and efficiently. Ideal for spinning or felting. The packer brush helps pack the carded fibres into the teeth of the large drum which allows more fibres to be carded and results in a thicker batt. It helps control fine low crimp fibres such as mohair, angora and alpaca. The two-speed ratios give flexibility and control when carding and blending. Use the 6:1 ratio to prepare your fleece. The controlled intake and carding will produce a smooth even batt ready for blending, spinning or felting. Use the 4:1 ratio to blend sliver, colours and different fibre types consistently into an open and airy batt.

Includes a cleaning brush for keeping the drums clean, doffer and clamps. The adjustable drum clearance allows you to set the teeth distance for total control of your fibre. All nylon bearings ensure it is light and easy to turn. The card cloth has wire teeth with a special protective coating and a flexible rubber backing for long life. The carder is strong and robust with the body made from Silver Beech hardwood. The carder has rubber feet to prevent it slipping. It comes assembled and lacquered ready to use. **NOTE:** To avoid the drive cord stretching, when not in use, please loosen the drive cord by moving it to a smaller pulley.

ADC160217V5

HOW TO USE

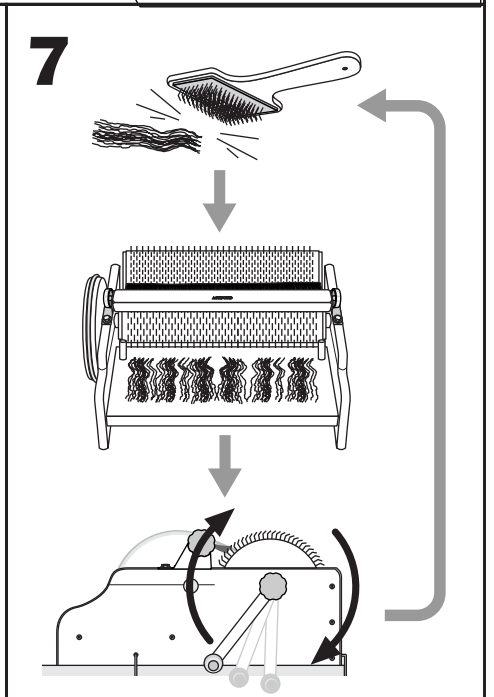
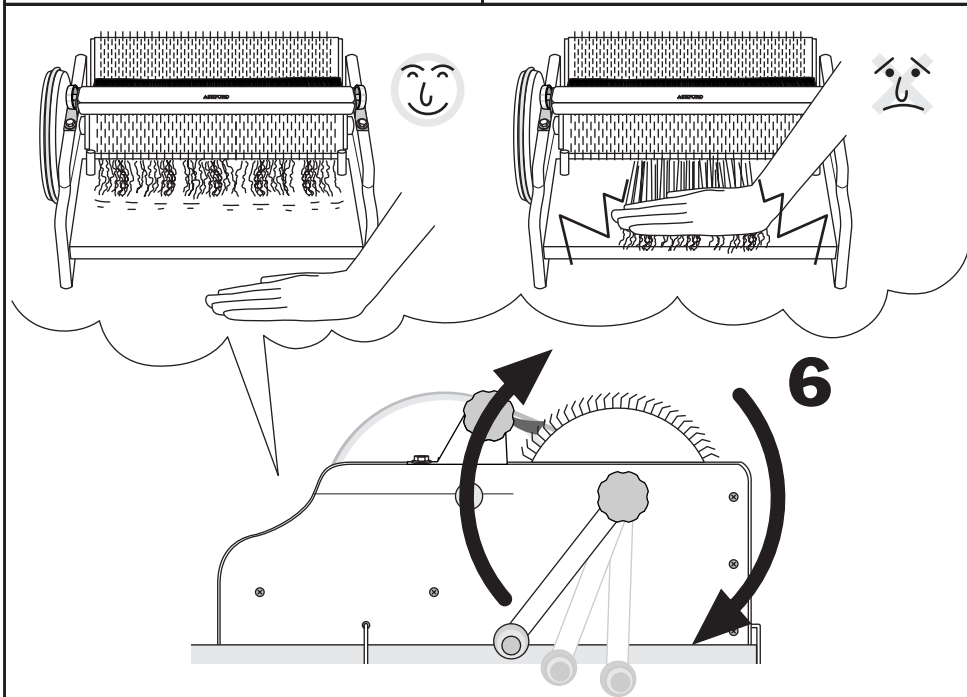
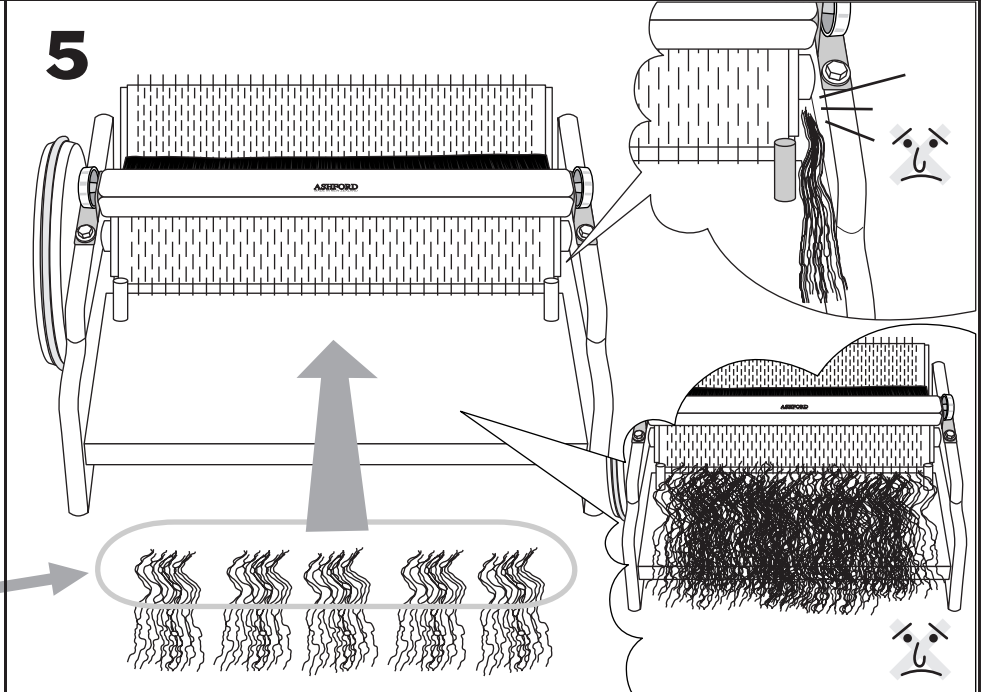
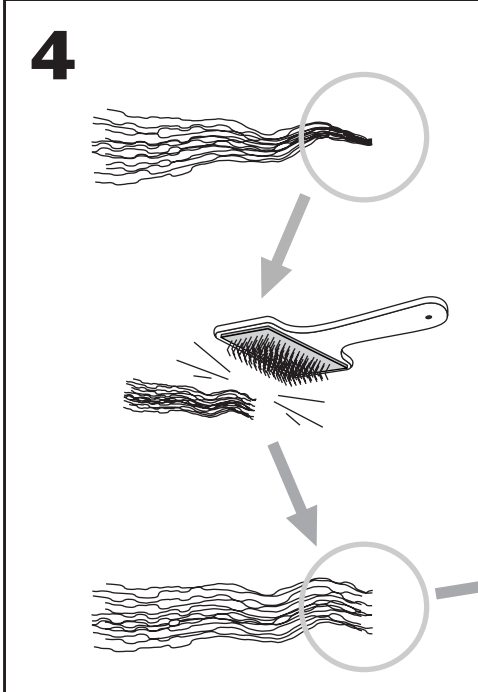
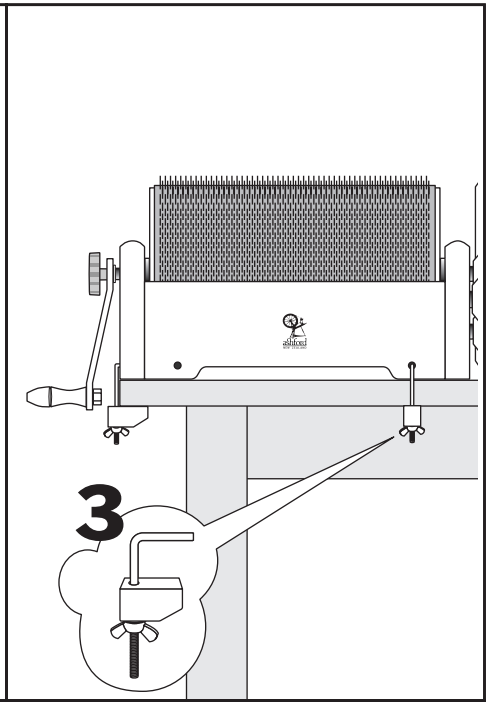
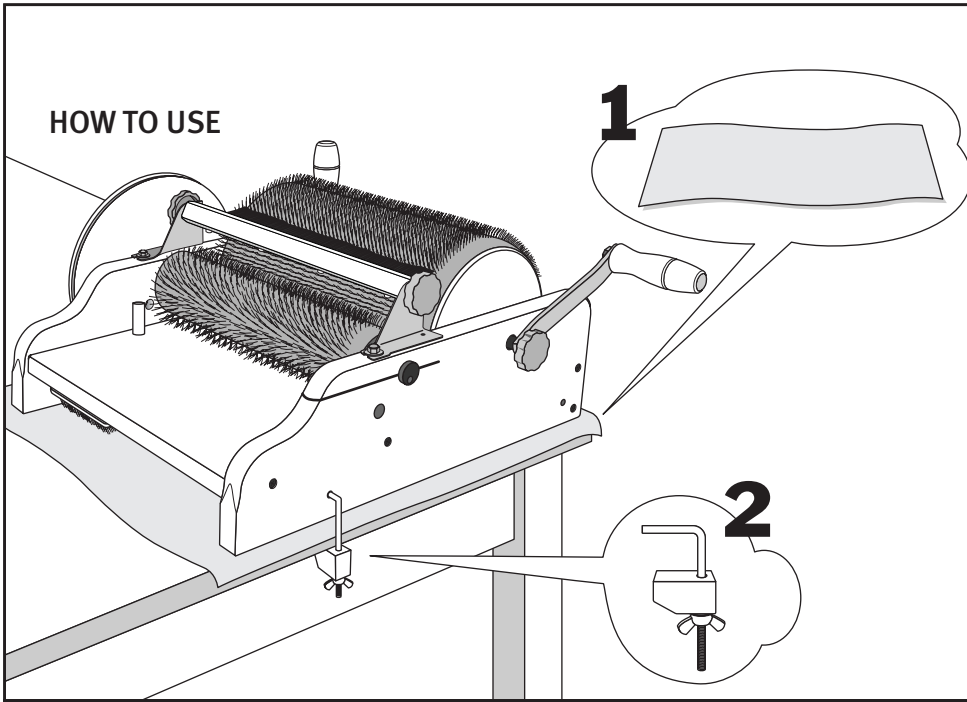

CHECK!

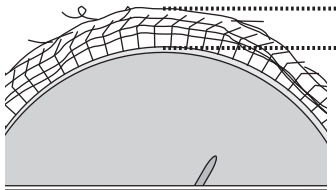
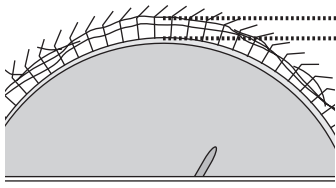

8

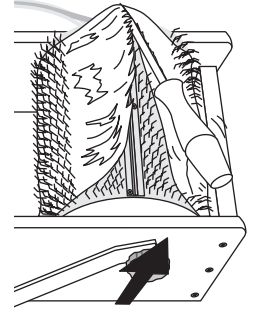
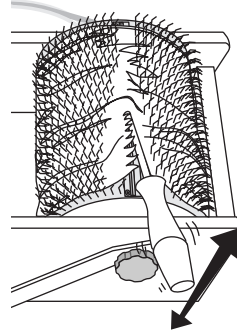
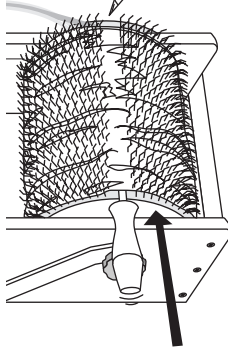
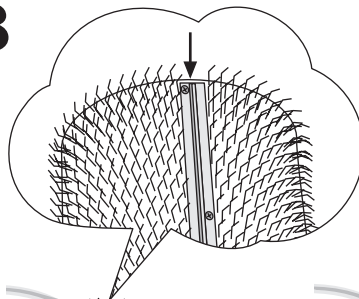

9

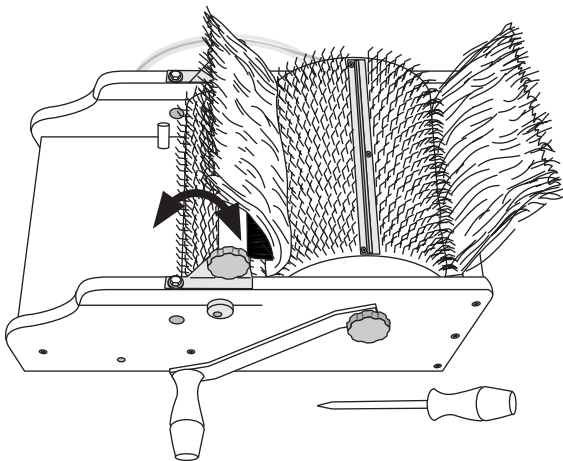

When the large drum is full or fibre starts collecting on the small drum, loosen the 2 knobs and twist the packer brush up out of the teeth.

10

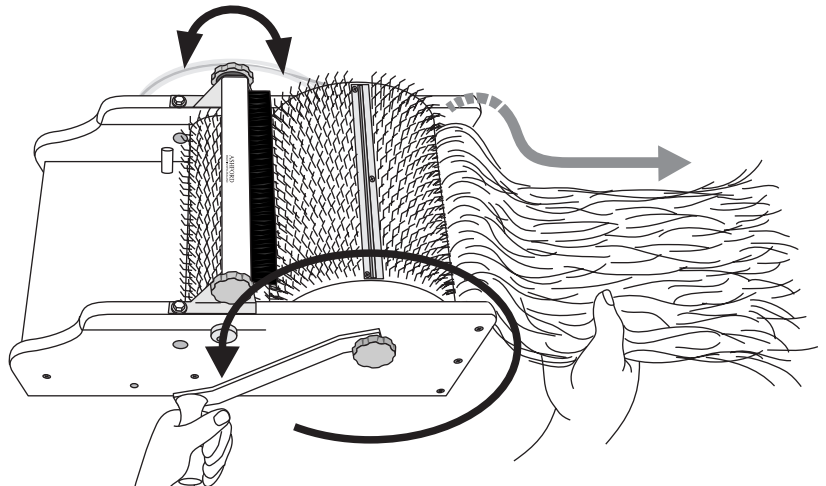

Remove the batt, clean the drums as necessary, reposition the brush into the carder teeth and tighten the 2 knobs. Experiment with the position of the packer brush to best suit the fibre you are carding.

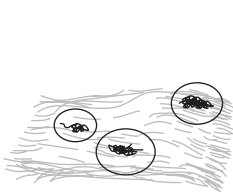

Second Carding

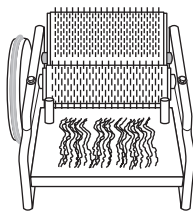

Hints!



Mixing Colours

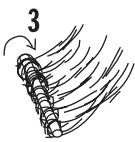
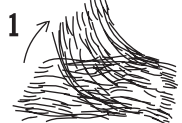
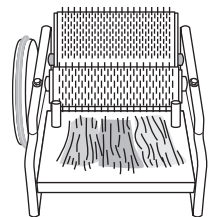

Rolags

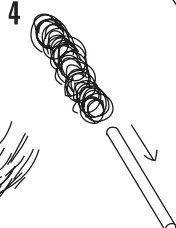

Felting

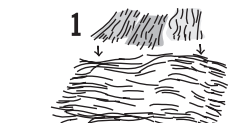
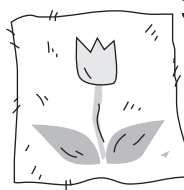

MAINTENANCE

Oil the bearings

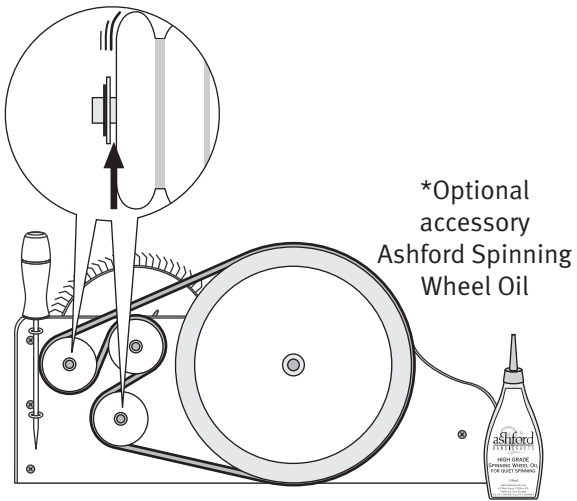

OIL

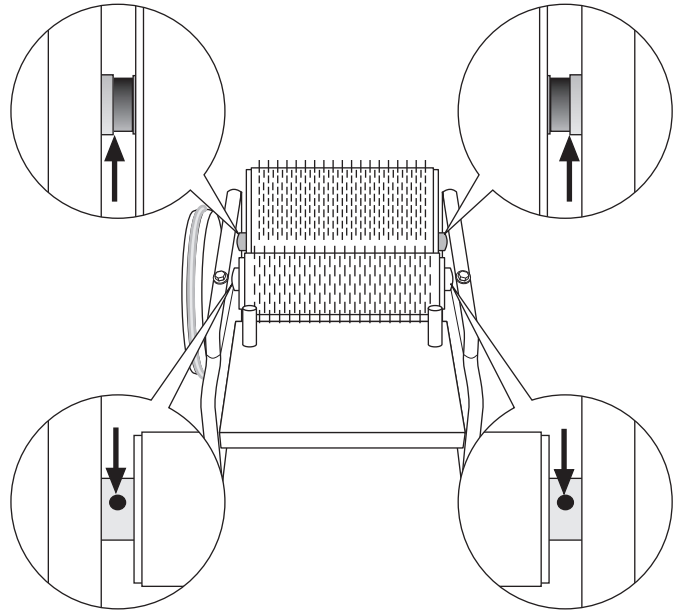

Cleaning

-Carding cloth-

Use the cleaning brush
to clean the drums.

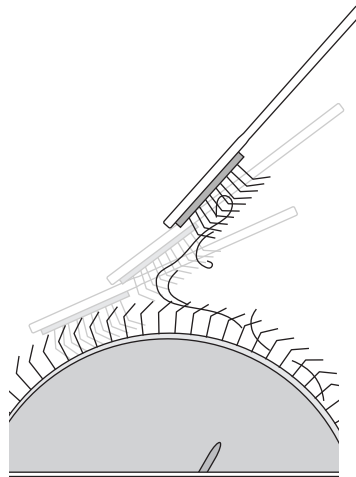
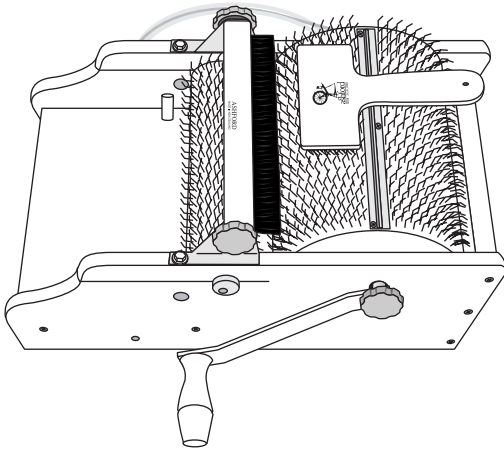

Cleaning

-Drum shafts-

If you find the handle hard
to turn...

You will need...

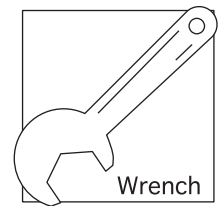

1

Remove the drive band

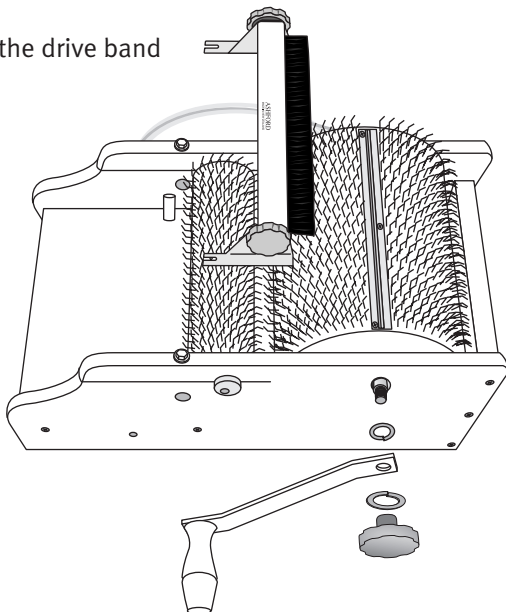

2

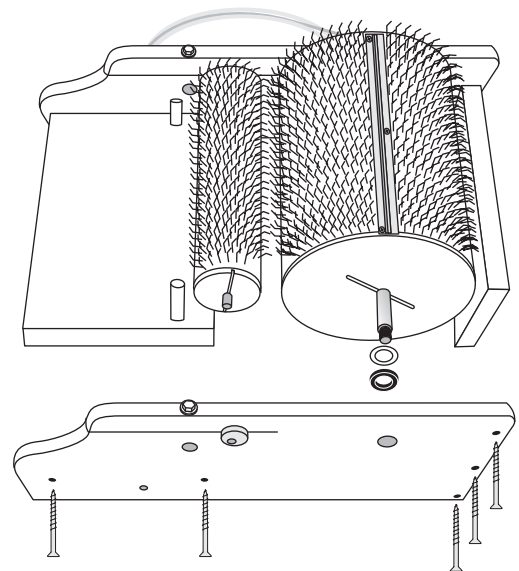

3

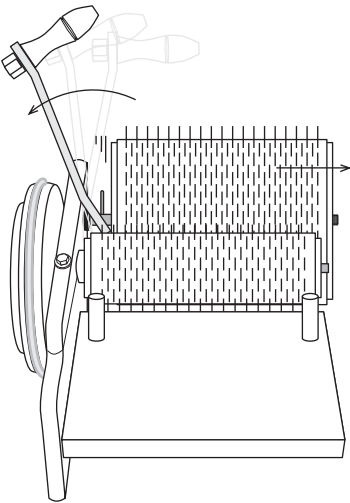

4

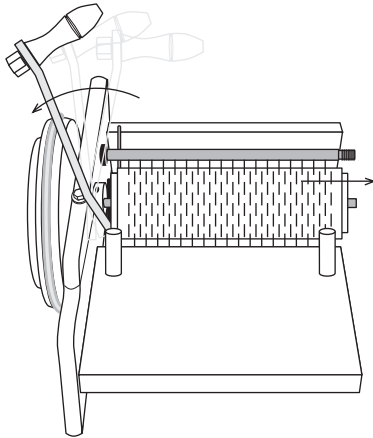

5

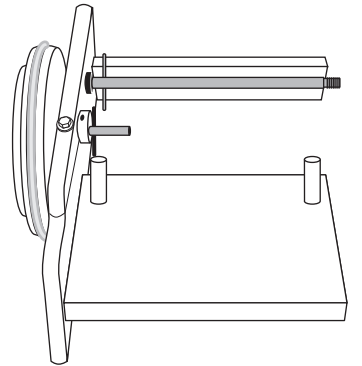

REASSEMBLING CHECK!

6

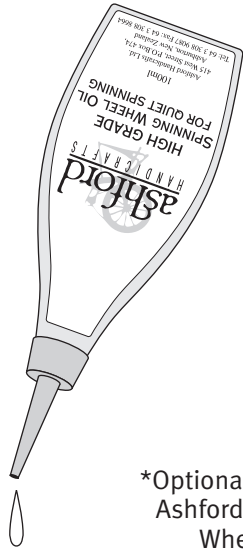

*Optional accessory
Ashford Spinning
Wheel Oil

7

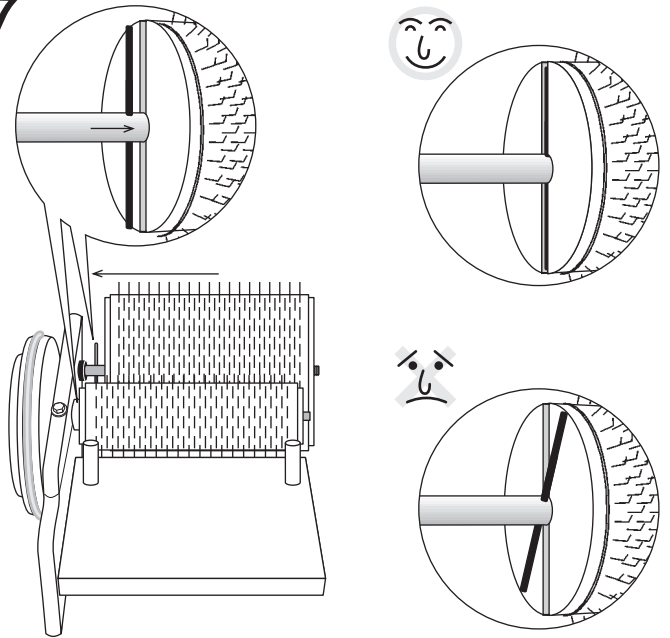

8

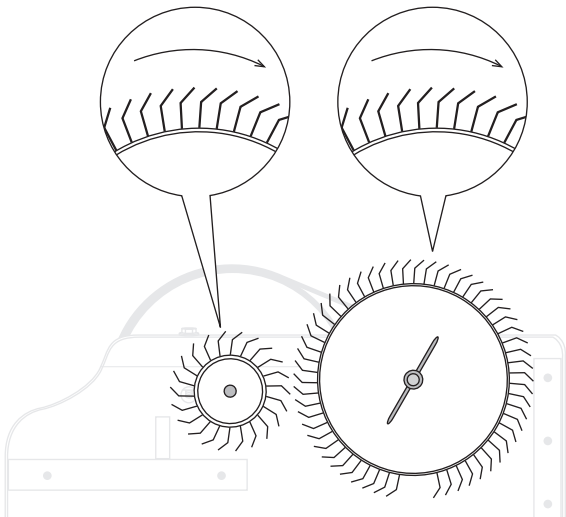

9

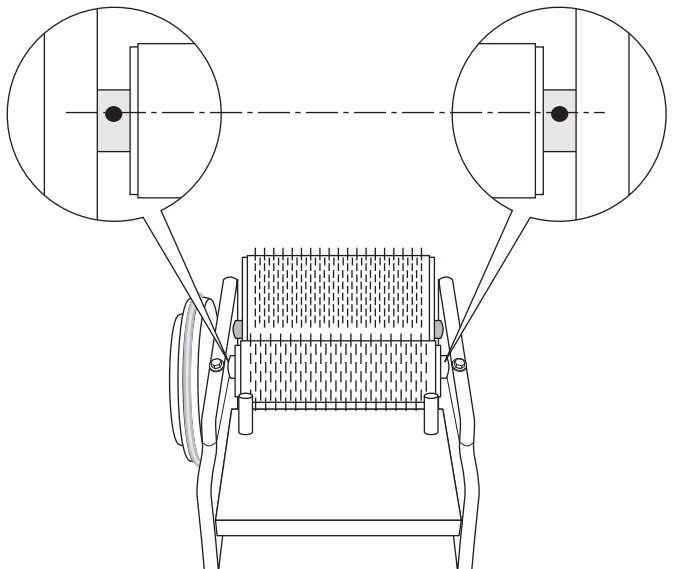

ADJUSTING

-Gap between teeth-

You will need...

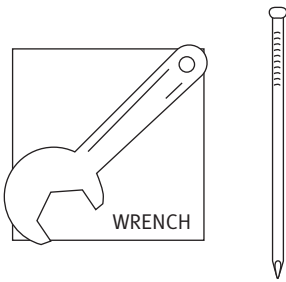

1 Remove the drive band.

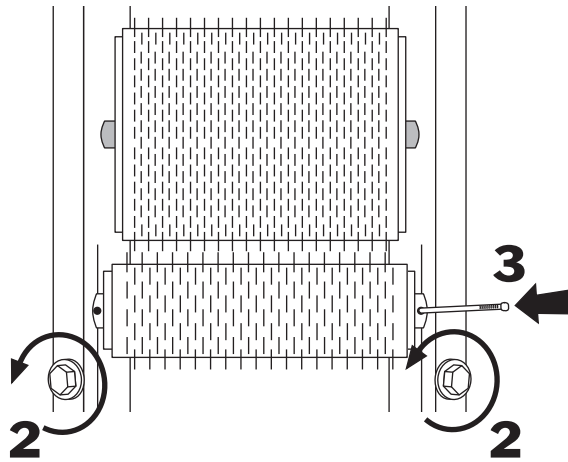

NOTE!

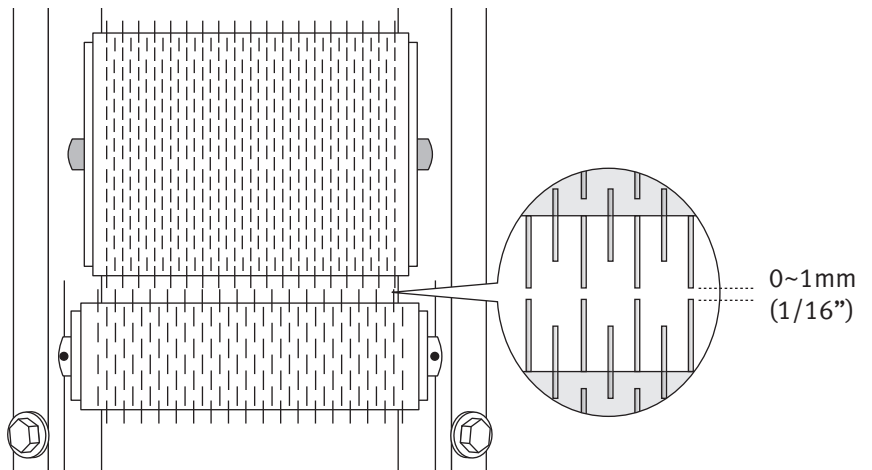
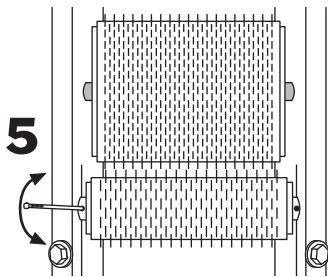
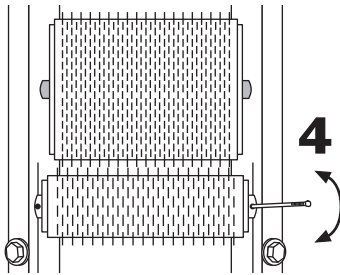
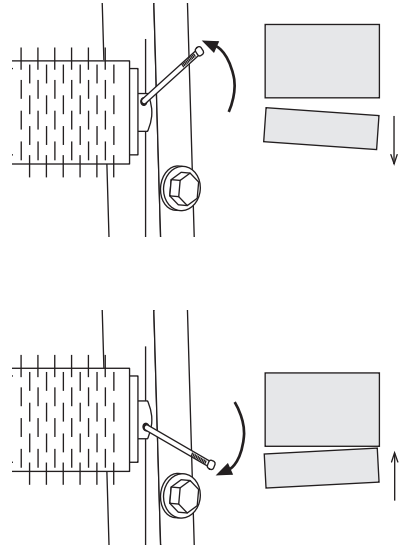

Hint!

To wash wool

The dirt and grease in unwashed wool can reduce the life of the carder.
Washed wool keep the carding cloth and teeth free from grease and grime.

