



By

Northern Fridge

TruckFridge

Built-in Manual



Model TF49



Model TFDR49



Model TF65



Model TF130

TruckFridge Built-in User Manual

TABLE OF CONTENTS

| | | | |
|------------|---------|--|--------------|
| 1.0 | | GENERAL INFORMATION | 4 |
| | 1.1 | Introduction | 4 |
| | 1.2 | Notice | 4-5 |
| 2.0 | | COMPONENTS | 5 |
| | 2.1 | Components/Refrigeration System Illustrations | 5 |
| | 2.1.1 | Compressor | 5 |
| | 2.1.2 | Electronic Control Unit (ECU) | 6 |
| | 2.1.2.1 | Replacing the ECU | 6 |
| | 2.1.3 | Condenser | 7 |
| | 2.1.4 | Evaporator | 7 |
| | 2.1.5 | Thermostat | 7 |
| | 2.1.6 | Fan | 7 |
| | 2.1.7 | Dehydration Filter (Dryer) | 7 |
| 3.0 | | INSTALLATION | 7-8 |
| | 3.1 | Installing the TF49 in Freightliner Cascadia | 8 |
| | 3.1.1 | Installing replacement TF49 with TF49-2PCAS-R Installation Kit | 8-9 |
| | 3.1.2 | Installing new TF49 with TF49-4PCAS-N Installation Kit | 10-11 |
| | 3.2 | TF130FK Installation Guide | 12 |
| | 3.3 | Ventillation | 13 |
| | 3.4 | Wiring System: Function and Features | 13 |
| | 3.4.1 | Wiring Connections | 13-14 |
| | 3.5 | Replacing the Door Panel | 14 |
| | 3.6 | Reversing the Door Opening | 15 |
| | 3.7 | Adjusting the Door Opening/Closing (TF49, TF65, TF86, TF130) | 16 |
| 4.0 | | FEATURES | 16 |
| | 4.1 | Setting the Inside Temperature | 16 |
| | 4.2 | Filling | 16 |
| | 4.3 | Defrosting | 16 |
| 5.0 | | MAINTENANCE | 16-17 |
| | 5.1 | Useful Advice | 17 |
| 6.0 | | TROUBLESHOOTING | 18 |
| | 6.1 | Troubleshooting Guide | 18 |
| | 6.2 | Self-Diagnostics | 18-19 |
| | 6.3 | Thermostat Test / Adjustment | 20 |
| | 6.3.1 | Thermostat Adjustment for TF49, TF65 and TF130 Models | 21-22 |
| 7.0 | | SPECIFICATIONS | 23 |
| | 7.1 | TruckFridge Model TF49 | 23 |
| | 7.2 | TruckFridge Model TFDR49 | 23 |
| | 7.3 | TruckFridge Model TF65 | 24 |
| | 7.4 | TruckFridge Model TF130 | 24 |

TruckFridge Built-in User Manual

| | | | |
|------------|-------|--|-----------|
| 8.0 | | ILLUSTRATIONS | 25 |
| | 8.1 | TF49 Fridge Parts Diagram | 25 |
| | 8.1.1 | TF49 Fridge Parts List/Description | 26 |
| | 8.1.2 | TF49 Cooling System Parts Diagram | 27 |
| | 8.1.3 | TF49 Cooling System Parts List/Description | 28 |
| | 8.2 | TFDR49 Fridge Parts Diagram | 29 |
| | 8.2.1 | TFDR49 Fridge Parts List/Description | 30 |
| | 8.2.2 | TFDR49 Cooling System Parts Diagram | 31 |
| | 8.2.3 | TFDR49 Cooling System Parts List/Description | 32 |
| | 8.3 | TF65 Fridge Parts Diagram | 33 |
| | 8.3.1 | TF65 Fridge Parts List/Description | 34 |
| | 8.3.2 | TF65 Cooling System Parts Diagram | 35 |
| | 8.3.3 | TF65 Cooling System Parts List/Description | 36 |
| | 8.4 | TF130 Fridge Parts Diagram | 37 |
| | 8.4.1 | TF130 Fridge Parts List/Description | 38 |
| | 8.4.2 | TF130 Cooling System Parts Diagram | 39 |
| | 8.4.3 | TF130 Cooling System Parts List/Description | 40 |
| | 8.5 | Danfoss/Secop BD35F-HD Compressor Specifications | 41-42 |
| | 8.6 | TruckFridge 101N0212 ECU 12VDC Specifications for BD35F-HD | 43 |
| | 8.6.1 | TruckFridge 101N0212 ECU 12VDC Wiring Diagram | 44 |
| | 8.7 | TruckFridge 101N0500 ECU 12VDC, 110VAC Specifications | 45 |
| | 8.7.1 | TruckFridge 101N0500 ECU 12VDC, 110VAC Wiring Diagram | 46 |
| | 8.8 | TF49 Dimensional Diagram | 47 |
| | 8.9 | TFDR49 Dimensional Diagram | 48 |
| | 8.10 | TF65 Dimensional Diagram | 49 |
| | 8.11 | TF130 Dimensional Diagram | 50 |
| | 8.12 | TruckFridge Installation Ventilation Diagram | 51 |

TruckFridge Built-in User Manual

1.0 GENERAL INFORMATION

1.1 Introduction

The TruckFridge Built-in refrigerator (TruckFridge) has been designed and tested to give many years of performance and reliability. The 12 and 24 Vdc power supply (110-220 Vac optional) makes them especially versatile. The power source can either be a battery, a transformer, a photo-voltaic (Solar) panel or common household 110Vac. Provided with a totally watertight compressor, they offer a minimal power consumption and noise level. All the models are extremely easy to install. They can work even if they are assembled at a slant of up to 30°. In order to make sure that your TruckFridge refrigerator works as efficiently as possible, please pay attention to the following general instructions:

- Never connect a battery charger directly to the refrigerator. A battery and in-line 15 amp fuse must be used to protect the compressor and Electronic Control Unit (ECU).
- Reduce opening the door of the refrigerator to reduce the waste of energy
- Proper ventilation of the compressor and of the condenser unit reduces the energy consumption and increases overall efficiency and performance.
- The wiring system of the vehicle is in proper condition. Routinely check the batteries and the charge level. Follow the instructions about the cable cross sections and the fuse connections strictly. See Section 3.5: *Wiring System: Function and Features* for details.
- Keep the inside of the refrigerator clean and dry. Remove any condensate water which might gather in the tray under the freezer compartment
- Keep the door of the refrigerator slightly open in order to air it out if you do not use it for a long time, for example in winter.

1.2 Notice

WARNING! Do not install the refrigerator near heat sources.

WARNING! Keep ventilation openings in the appliance enclosure or in the built-in structure, clear of obstruction.

WARNING! Do not use mechanical devices or other means to accelerate the defrosting process, other than those recommended by the manufacturer.

WARNING! Do not damage the refrigerant circuit during handling.

WARNING! Do not use electrical appliances inside the food storage compartments of the appliance, unless they are of the type recommended by the manufacturer.

WARNING! Do not store explosive substances such as aerosol cans with a flammable propellant in this appliance.

WARNING! Risk of fire and electrical shock or fire.

WARNING! Do not let hot items to touch the plastic parts of the appliance.

WARNING! Do not store flammable gas and liquid in the appliance.

WARNING! Do not put flammable products or items that are wet with flammable products in, near or on the appliance.

WARNING! Do not touch the compressor or the condenser. They may be hot.

TruckFridge Built-in User Manual

WARNING!

- The refrigerator is suitable for the preservation and/or storage of food items and maintaining already frozen food.
- Use the fridge exclusively for cooling and storing closed beverages and snacks.
- Food may only be stored in its original packaging or in suitable containers.
- The fridge is not intended to be brought into contact with food.
- The fridge is not intended for the proper storage of medicines. See the instructions in the package leaflet for the medicinal product.

2.0 COMPONENTS

2.1 Components/Refrigeration System Illustrations

Model TF49

See 8.1 TF49 Fridge Parts Diagram.

See 8.1.1 TF49 Fridge Parts List/Description.

See 8.1.2 TF49 Cooling System Parts Diagram.

See 8.1.3 TF49 Cooling System Parts List/Description.

Model TFDR49

See 8.2 TFDR49 Fridge Parts Diagram.

See 8.2.1 TFDR49 Fridge Parts List/Description.

See 8.2.2 TFDR49 Cooling System Parts Diagram.

See 8.2.3 TFDR49 Cooling System Parts List/Description.

Model TF65

See 8.3 TF65 Fridge Parts Diagram.

See 8.3.1 TF65 Fridge Parts List/Description.

See 8.3.2 TF65 Cooling System Parts Diagram.

See 8.3.3 TF65 Cooling System Parts List/Description.

Model TF130

See 8.4 TF130 Fridge Parts Diagram.

See 8.4.1 TF130 Fridge Parts List/Description.

See 8.4.2 TF130 Cooling System Parts Diagram.

See 8.4.3 TF130 Cooling System Parts List/Description.

2.1.1 Compressor

The TruckFridge refrigerator uses the Direct Current Danfoss/Secop BD35F-HD compressor that is specially designed for extraordinary performance at minimum power consumption, superbly silent-running and reliable operation even when tilted up to 30 degrees.

HD (Heavy Duty) version of the BD35F which can handle extreme vibrations.

2.1.2 Electronic Control Unit (ECU)

The Electronic control unit of the compressor is a piece of electronic equipment which carries out all the controls and electrical protection of the compressor system. Its main features include;

- a) Protection of the battery with automatic turning off of the compressor when the feeding voltage reaches the minimum threshold (cut out) typically 10 volts. The compressor will start up automatically again when the voltage goes back to normal values (cut in). Typically 11 volts. Must always be directly connected to the battery.
- b.) Thermal overload protection cut out. The compressor will shut down when temperatures exceed 125 deg F ambient to protect the compressor from overheating. It will cut in automatically when temperatures drop below this.
- c.) Cooling fan operation will begin automatically when compressor starts and stop when compressor shuts off in normal operation.

The main functions of the 101N0212 is to provide all controls for the BD35F-HD compressor systems including:

- Supports both 12VDC (max. 17VDC) and 24VDC (max. 31.5VDC)
- Maximum ambient temperature is 55°C with built-in thermal protection
- Motor / Compressor speed control
- Thermostat control (ON / OFF)
- Condenser fan control including speed setting
- Error codes
- Battery protection functions. Polarity inversion protection.

See 8.6.1 *TruckFridge 101N0212 ECU 12VDC Specifications for BD35F-HD.*

2.1.2.1 Replacing the ECU

The ECU can be simply removed and/or installed by removing a screw to release module for the side of the compressor to reveal the 3-pin plug that attaches the ECU to the compressor. Follow these simple steps;

1. Disconnect all terminals (22) from the control ECU and, while doing so, mark them adequately, so as not to connect them wrongly during reassembly. See *Figure 2.1.2.1.1*
2. Unscrew the screw (23). See *Figure 2.1.2.1.2.*
3. Disconnect the connector (24) from the ECU, from the compressor (25). See *Figure 2.1.2.1.3*
4. Replace the damaged ECU by first assembling the left hand side and afterwards press the right hand side on the screw head on the bracket. In this way the ECU gets locked on the bracket and is securely fastened to the compressor.

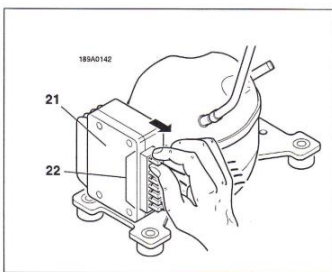

Figure 2.1.2.1.1

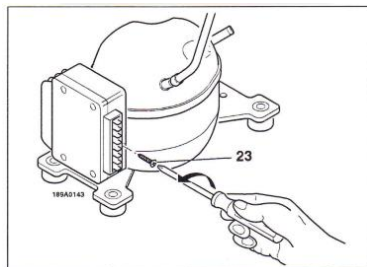

Figure 2.1.2.1.2

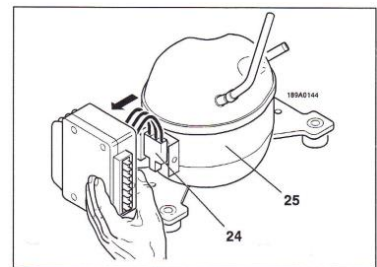

Figure 2.1.2.1.3

TruckFridge Built-in User Manual

2.1.3 Condenser

The condenser may be of static or ventilated type. Since its function is to dissipate heat, it must be placed in a zone allowing for the maximum heat exchange with the environment and must not be clogged with dust or other substances preventing the exchange of heat. See *8.12 TruckFridge Installation Ventilation*.

2.1.4 Evaporator

The evaporator is the element where the gas is expanded causing heat absorption thereby cooling the ambient air around it. The capillary pipe is an integral part of the evaporator that creates a narrow path for the gas causing a pressure difference between the circuit delivery and suction. If the capillary pipe gets obstructed, the entire evaporator must be replaced.

2.1.5 Thermostat

The *TruckFridge* is provided with a manual thermostat located inside the refrigerator on the upper right side next to the freezer. Turn the knob clockwise to lower (1) the temperature and turn counter-clockwise to raise (7) the temperature and activate the ON-OFF switch in its end (0) position.



In case of anomalies or fault, the thermostat cannot be repaired and must be replaced. See *Figure 2.1.5.1: TruckFridge Thermostat*

Figure 2.1.5.1: TruckFridge Thermostat

2.1.6 Fan

The electronic type fan, with brushless motor, for an almost unlimited lifespan. The fan is connected between the ECU (+) and "F" terminals. A 12VDC fan is always used for both 12VDC and 24VDC power sources. In case of damage, the fan must always be entirely replaced.

2.1.7 Dehydration Filter (Dryer)

The dryer has the double task of blocking any solid impurity through a metal mesh and of absorbing any possible humidity (moisture) present in the fluid by means of a highly hygroscopic molecular sieve. Always replace the sieve every time the circuit is opened for repair.

3.0 INSTALLATION

The refrigerators from TruckFridge are assembled to be installed in a standard factory cabinet. In some cases, if the truck was not equipped with a fridge from the truck factory, the cabinet may be slightly different and require a slight modification to install a fridge. Note any additional instructions included with the packing list when purchasing the fridge new. The fridge weight must always be sitting on its feet to support the weight. In some cases, a block may be needed under the bottom of the fridge to lift it off the floor of some cabinets to fill in gaps at the top. This allows air to enter the cabinet from the bottom. In other cases, a filler strip may be needed to make up gaps in the side of some truck cabinets that were not originally designed for fridge.

See the following dimensional diagrams listed below for further details.

See *8.8 "TF49 Dimensional Diagram"* for details.

See *8.9 "TFDR49 Dimensional Diagram"* for details.

See *8.10 "TF65 Dimensional Diagram"* for details.

See *8.11 "TF130 Dimensional Diagram"* for details.

TruckFridge Built-in User Manual

Most models from TruckFridge can be installed by attaching the applicable fridges installation kit(s) to the truck cabinet using the appropriate screws required for the material of the truck cabinet.

It is very important for the refrigerating unit, consisting of the compressor and the condenser, to be well ventilated, with the cool air typically coming in from the bottom and going out from the top. You must ensure proper ventilation of the refrigerating unit. The air inlets and outlets must have a free cross section of at least 10 square inches total. See *8.12 TruckFridge Installation Ventilation Diagram* for details.

WARNING !!

DO NOT POWER ON THE FRIDGE FOR A MINIMUM OF 4 HOURS AFTER INSTALLATION.

The compressor must normally stand in a vertical position. During shipping, the fridge may be turned on its side or upside down. This may cause the compressor oil to drain from the compressor into the capillary pipe thereby obstructing operation of the evaporator. You must allow time for the oil to drain back into the compressor for proper lubrication. FAILURE TO DO THIS MAY DAMAGE THE COMPRESSOR AND/OR EVAPORATOR AND VOID YOUR WARRANTY.

Take great care when handling the fridge and avoid handling the refrigeration tubes in order to prevent breakages. The compressor must normally stand in a vertical position.

3.1 Installing the TruckFridge Model TF49 in Freightliner Cascadia.

3.1.1 Installing a replacement Model TF49 with TF49-2PCAS-R Installation Kit

The *TF49-2PCAS-R* 2 piece Freightliner Cascadia replacement installation kit is used to replace an OEM refrigerator in a Freightliner Cascadia that previously had a factory installed refrigerator (black steel mounting plates are still mounted in the bottom of the truck cabinet). The *TF49-2PCAS-R* installation kit must be installed on the bottom of the TF49, then simply slide in the new refrigerator on the existing floor bracket, bolt it into place and the new refrigerator is installed.

Remember. This is ONLY for Freightliner Cascadia that already has the factory fridge black bottom mounting plate and top bracket already in the cabinet. If your Freightliner Cascadia cabinet does not have the factory bottom black mounting plate inside the cabinet, you will need to order the complete [TF49-4PCAS-N](#) installation kit.

WARNING !

- Insure thermostat is turned off inside the fridge before continuing.
- Insure fridge has been sitting upright for a minimum of 4 hours before turning on ! Failure to do so may destroy compressor and void warranty!

Remove the 3 sided trim flange from the fridge and discard. Reinstall the screws into the original holes.

The galvanized plate and top "L" brackets included in the kit must be attached to the bottom and top of the TF49 as described below.

Carefully turn the fridge upside down and set it on top of the Styrofoam shipping lid. Align the bottom bracket 1/2" from front of fridge cabinet, not the door, and centered side to side. (If silicone caulking is available, apply a small amount to each screw hole in bracket to minimize potential of screws loosening.) Install bracket using 3/4" long #10 sheet metal screws. See Figure 3.3.1.1: Attaching bracket to bottom of fridge.

TruckFridge Built-in User Manual

3.1.2 Installing a new Model TF49 with TF49-4PCAS-N Installation Kit

The TF49-4PCAS-N is a 4 piece Freightliner Cascadia Installation Kit required for installing the TF49 in Freightliner Cascadia cabinets that did not originally have a factory refrigerator installed. (Note. The *TF49-4PCAS-N* installation kit includes the TF49-2PCAS-R installation Kit).

Install and bolt in place the black “bottom” mounting plate to the floor of the cabinet using existing holes in cabinet. No drilling required. Refrigerator plugs into existing factory wiring harness from the REAR of lower cigarette type plug. (NEVER USE A CIGARETTE PLUG AS A PERMANENT CONNECTION.)

Next, install the TF49-2PCAS-R Installation Kit to the “bottom” of the TruckFridge TF49 as described in “3.3.1: Installing a replacement refrigerator with the TF49-2PCAS-R Installation Kit” above.

Installation time is also faster and typically takes about 1/2 hour for an average person. This kit contains all the hardware needed. Requires basic hand wrench and socket and possibly a drill. NOTE: If your cabinet has a door, this will need to be removed. Freightliner does sell a trim bezel for this cabinet when a fridge is installed. Freightliner Cascadia Fasica fridge cabinet trim frame without wood grain (#A18-62503-002).

Note: Some trucks vary depending on specification at time of manufacture. TruckFridge assumes no responsibility or liability as a result of variations on trucks specs.

Removing the trim frame on the truck cabinet:
Some models may be held in place with 4 screws from the back side. In this case, remove the clip nuts from the trim frame. These will need to be replaced with included plastic “trees” as screws cannot be reinstalled once the fridge is mounted. Some frames are held in place with push clips. These can be reused.



If your vehicle came without a factory installed fridge, locate 12v accessory power point plug at rear of shelf. Reach underneath to unlock and push power plug and wire up through hole in shelf.



TruckFridge Built-in User Manual

Align large black mounting plate with existing holes already in cabinet platform. They can be located from bottom, if shelf is covered with carpet, poke up through holes and through the carpet. (Carpet removed in picture for demonstration purpose only.)



Bolt mounting plate to bottom of cabinet with finger tabs along the back of the cabinet, pointed up and toward center of truck. Check to be sure fridge thermostat is turned off in case unit has been tilted during installation. Connect the fridge power plug to the truck power cord plug.

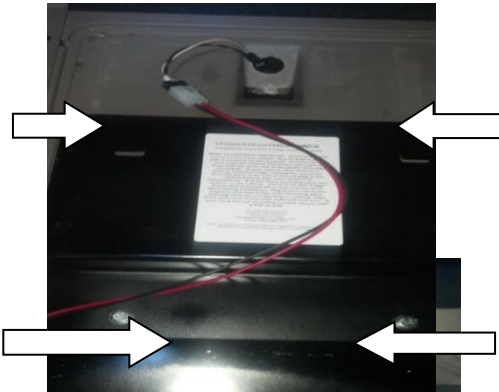

If your cabinet does not have a top mount bracket, use small black TF top bracket with black push clips and secure to bracket in the top of cabinet. This will bolt to TF top fridge bracket. If your truck already has top mounting bracket as shown here, the TF top bracket and push clips will not be needed.

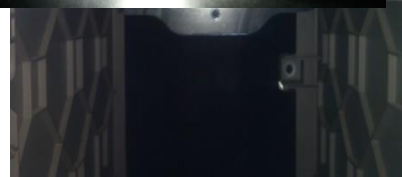

Slide fridge on to mounting plate, aligning rear finger tabs to fridge bottom plate. Insure wires are not pinched or rubbing. Align front holes and secure with included bolts and lock nuts.



Install cabinet trim frame using plastic "trees" as mentioned previously. Fridge light will be on when door is open even when thermostat is in "0" Off position. Do not turn fridge on until it has remained in upright position at least 4 hours prior to being installed.



3.2 TF130FK Installation Guide

TF130FK Flange Kit Installation

1. Place the vented upper flange on top of the fridge, remove the two existing screws, align upper flange with holes and reinstall the 2 screws.
2. Locate the (4) holes on the side flange as shown in the diagram. Align side flange with the upper flange. Using a marker, mark the position of the (4) holes.
3. Drill each mark with a 3/32" drill bit. Note. Drill only up to 1/2" deep into the side of the fridge.
4. Attach the side flange using the (4) screw provided. Note. Do not over tighten. Repeat for opposite side

indelB
INDEL B NORTH AMERICA
INC 100 TRIPORT CIRCLE
GEORGETOWN, KY 40324

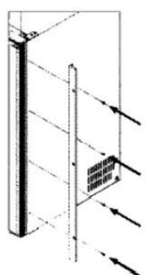
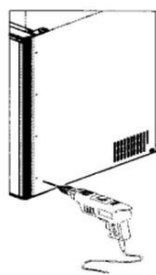
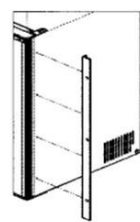
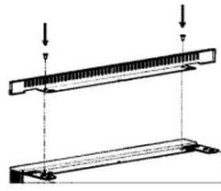

1. Place the vented upper flange on top of the fridge, remove the two existing screws, align upper flange with holes and reinstall the 2 screws.

2. Locate the (4) holes on the side flange as shown in the diagram. Align side flange with the upper flange. Using a marker, mark the position of the (4) holes.

3. Drill each mark with a 3/32" drill bit. Note. Drill only up to 1/2" deep into the side of the fridge.

4. Attach the side flange using the (4) screw provided. Note. Do not over tighten. Repeat for opposite side

Updated 7 September 2021

Version v2.4

Page 12

TruckFridge Built-in User Manual

3.3 Ventilation

It is very important for the refrigerating unit, consisting of the compressor and the condenser to be well ventilated with adequate air flow into and out of the cabinet housing the refrigerator. See *8.12 TruckFridge Installation Ventilation Diagram* for details. Do not install the refrigerator near heat sources

3.4 Wiring System: Function and Features

The Electronic Control Unit (ECU) is a piece of electronic equipment which controls the motor of the compressor and carries out all the controls and electrical protection of the system. The ECM provides protection of the battery with automatic turning off of the compressor when the feeding voltage reaches the minimum threshold level (cut out). The compressor will start up automatically again when the voltage goes back to normal values (cut in). See *Table 3.4: ECM Cut-Out / Cut-In Voltages*.

| FEEDING | CUT IN | CUT OUT |
|---------|--------|---------|
| 12 V | 11.7 V | 10.4 V |
| 24 V | 22.6 V | 21.3 V |

Table 3.4: ECU Cut-Out / Cut-In Voltages

3.4.1 Wiring Connections

Typically, your TruckFridge will have the correct gauge wire and connector installed on the fridge to connect to the standard truck factory wiring. If the truck was not equipped with a fridge from the factory, the manufacturer would often connect the fridge wire to a 12v cigarette type receptacle. In these cases, unplug the connector from the rear of this receptacle and plug this into the connector on the fridge wires. NOTE: There are proper wire connectors available from TruckFridge for most truck wiring installations.

When you connect the refrigerator, you must remember the following:

- 1) Use cables having the proper cross section to make the feeding lines. If possible, such cables should be without any joints on the leads which could lead to voltage falls. See “Table 3.4.1: 12VDC Wire Gauge Chart” below.
- 2) If the wiring system of the vehicle is insufficient or not properly sized for the refrigerator, we suggest you connect it directly to the battery. Note. The use of cables having an insufficient cross section may lead to the compressor stopping even when the battery is charged.
- 3) Any switches must have a breaking load not less than 20 A (10 A if powered at 24 Volt).

| Cross-section (mm ²) | AWG Section | Max 12V Cable Length m/ft | Max 24V Cable Length m/ft |
|----------------------------------|-------------|---------------------------|---------------------------|
| | | BD1.4F / BD35F / BD50F | |
| 2.5 | 12-14 | 2.5 / 8 | 5 / 16 |
| 4 | 10 | 4 / 12 | 8 / 26 |
| 6 | 8 | 6 / 20 | 12 / 40 |
| 10 | 6 | 10 / 32 | 20 / 65 |

Table 3.4.1: 12VDC Wire Gauge Chart

- 4) Make sure the polarity is right: connect the RED cable to the positive terminal (+) and the BLACK cable to the negative terminal (-).

TruckFridge Built-in User Manual

- 5) For system protection, the fuse must be installed in the RED positive wires (+) as close as possible to the battery. We recommend using 15 A fuses for 12 V and 7.5 A fuses for 24 V. If using a main switch, it must be able to withstand a minimum current of 20 A. Avoid extra junctions in wiring to prevent voltage drops that can influence battery protection settings.

WARNING!

Never connect bare electric wire(s) and use only connectors of a size suitable to the cross section of the cable being used.

Never connect the refrigerator power to a cigarette lighter plug. Always connect directly to the battery.

3.5 Replacing the Door Panel (TF49, TF65 and TF130 ONLY)

Warning

The front panel on the TFDR49 is solid and cannot be replaced. Front panel options include Black (TFDR49DC-BL) and stainless steel (TFDR49DC-SS).

You can replace the door panel on the TF49, TF65 and TF130 without having to dismantle the door of the refrigerator, by proceeding as follows:

1. Take out the two front screws (39) which hold the handle in place. Do not need to remove bottom screw.
2. Remove the profile strip which anchors the panel located at the bottom of the door using a screwdriver as a lever. Remove the profile strip by rotating the screw driver (do not apply downward pressure). See video at <https://www.northernfridge.ca/pages/door-panel-replacement>.
3. Pre-drill holes in the new panel to reattach the door latch.
4. Fit in the new panel, letting it slide, and put back the profile strip and door latch.

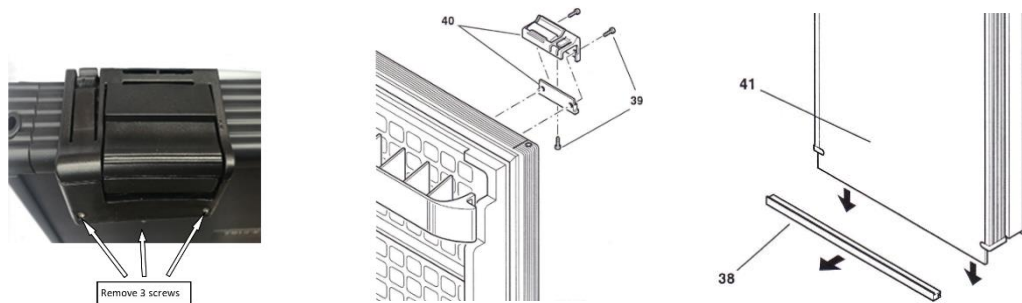

Figure 3.5: Replacing Door Panel

TruckFridge Built-in User Manual

3.6 Reversing the Door Opening (TF49, TF65 and TF130 Only)

The *TruckFridge* door can open from either the right or left. To change the side, move the hinges and door latch as shown in *Figure 3.6 "Reversing Door Opening"* below. Image of refrigerator shown is generic and may not represent your exact model, however the procedure is similar.

IMPORTANT WARNING.

Turn fridge OFF (disconnect 12V plug from battery). When finished reversing the door **DO NOT POWER ON THE FRIDGE FOR AT LEAST 4 HOURS**. Failure to do so can damage the compressor and void warranty.

- 1 Remove (3 x 3/4") screws from top black flange and remove.
- 2 Remove (4 x 3/4") screws holding top door bracket and remove. CAUTION. Remove rubber washer/"O" ring and put aside so as not to lose it.
- 3 Remove door.
- 4 Place fridge on its side and remove (4 x 3/4") screws holding bottom door bracket and remove. CAUTION. Remove rubber washer(s)/"O" ring and put aside so as not to lose it.
- 5 Remove (4 x 3/4") screws fastening the bottom flat kick bracket (no pin) from opposite side of bottom door bracket and replace on opposite side using same (4 x 3/4") screws. Do not over tighten.
- 6 Replace bottom door bracket to opposite side using (4 x 3/4") screws. Do not over tighten.
- 7 Turn fridge back upright.
- 8 Replace rubber washer/"O" ring onto bottom door bracket pin.
- 9 Replace door into bottom door bracket pin and then attach upper door bracket pin into door using the rubber washer/"O" ring.
- 10 Replace upper door bracket using (4 x 3/4") screws. Tighten only after the door has been aligned correctly to open and close easily. Do not over tighten.
- 11 Replace top flange using (3 x 3/4") screws. Do not over tighten.
- 12 Remove (2 x 7/8") screws from front of door latch and remove door latch. Note. Do not remove bottom screw.
- 13 Reposition door latch to opposite side. Using a 5/64" drill or sharp awl, drill or punch two new holes in front panel using door latch to located position of holes. Replace latch with (2 x 7/8") screw.
- 14 If applicable, carefully remove the front panel "TruckFridge" vinyl sticker using a sharp knife or use a glue type solvent to remove sticker). CAUTION. Do not scratch or damage the front panel.
- 15 **Contact Northern Fridge at support@northernfridge.ca or call (877) 322-7283 who will send you a replacement sticker to cover the two old holes.**

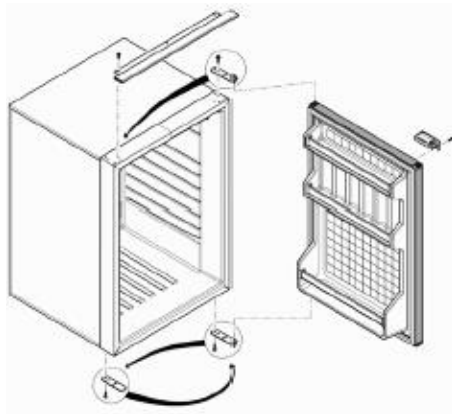

Figure 3.6: Reversing Door Opening

TruckFridge Built-in User Manual

3.6 Adjusting the Door Opening/Closing (TF49, TF65, TF86, TF130)

1. Determine which way the door needs to travel.
2. Barely loosen both the top and bottom hinge screws – all four on each hinge.
3. If the bottom of the door needs to go up and to the left, tap the bottom hinge to the left and the top hinge to the right. Then retighten the hinge screws starting with the top hinge first.
4. If the bottom of the door needs to go down and to the right, tap the bottom hinge to the right and the top hinge to the left. Then retighten the hinge screws starting with the top hinge first.

4.0 FEATURES

4.1 Setting the Inside Temperature

The TruckFridge refrigerators are provided with a manual thermostat. Turn it clockwise to lower (7 lowest) the temperature and turn it counter-clockwise (1 highest) to raise the temperature and activate the ON-OFF switch in its end position (0). The knob of the thermostat is located inside the refrigerator.



Figure 2.1.5.1: TruckFridge Thermostat

4.2 Filling

Do not put hot food into the refrigerator. Place the products in a position where they do not hit each other or break while the vehicle is moving. Make sure the door is always well closed and reduce opening time to a minimum to reduce power consumption.

4.3 Defrosting

Defrosting must be carried out when the ice layer is thicker than 3.2 mm (1/8"). Set the thermostat at the OFF position. While defrosting, keep food and beverages in a cool place. **DO NOT USE ANY SHARP METAL OBJECT TO REMOVE THE ICE OR FROST.** Do not start the refrigerator up again until it is completely defrosted and dry. Also empty the tray under the freezer compartment.

5.0 MAINTENANCE

The TruckFridge refrigerators have a completely watertight cooling system, and do not need any maintenance or reloading of the coolant. The compressor is of a domestic type, is highly efficient and has an extraordinarily long life. General maintenance merely consists of;

- routinely cleaning the condenser from dust, at least once a year. Use a soft brush and no hard object.
- regularly clean the inside and outside of the refrigerator using only warm water and a neutral detergent. Subsequent to washing, rinse with clean water and dry thoroughly using a soft cloth.
- Do not use the following: special glass and mirror cleaning products, liquid, powder, or spray detergents, alcohol, ammonia or abrasive products.

TruckFridge Built-in User Manual

- If you are not using the minibar, we suggest cleaning it well inside and leaving the door ajar to ventilate the interior. To do so, release the lock of the door using a coin or a small screwdriver.

5.1 Useful Advise

1. If the TruckFridge does not work properly, check the following before calling customer support;
 - a. make sure power is not missing.
 - b. the voltage which reaches the ECU is equal to the one shown on the plate (minimum 11 volts, maximum 14 volts) .
 - c. the connections have the proper polarity and are secure.
 - d. the condenser fan is not jammed or obstructed.
 - e. the refrigerating unit is not near a source of heat.
 - f. the in-line fuse mounted on the feeding line is not blown.
2. Heavy frost buildup can be caused by several factors:
 - 1 Warm foods introduced into the freezer or fridge section.
 - 2 Fridge door frequently opened and closed (especially in a high humidity environment).
 - 3 Fridge door not properly aligned with fridge body as to affect the rubber seals ability to seal as designed.
 - 4 Failure of the putty seal between the back wall of the fridge and the evaporator tube. Would need to be examined and resealed with existing putty.
 - 5 Certain foods, mainly leafy vegetables, have a tendency to cause ice to form faster due to their high moisture content.

Note: If the ice builds up more than 1/8 inch on either side, it can interfere with the freezer door opening and shutting properly and can cause the freezer door to pop loose and reduces the ability of the fridge to cool properly and the fridge will need to be defrosted. It goes without saying, the fridge needs to defrost naturally by turning off power and opening the door.

WARNING !

The user needs to be reminded to not use ANY object to pry ice loose or to use any heat source to speed up the defrost process as damage will occur. Make sure the fridge is thoroughly dry inside before restarting and remove excess moisture from any food and/or food packaging.

TruckFridge Built-in User Manual

6.0 TROUBLESHOOTING

6.1 Troubleshooting Guide

| Fault | Possible cause | Action |
|---|--|---|
| Fridge not cold, compressor will not start. | No power supply. Battery in poor condition. Faulty thermostat. Faulty electronic unit. | Check that power is present at electronic unit. Check fuse. Check polarity on connectors and cables. Bridge the thermostat over T-C, see wiring diagram. If compressor starts, this indicates a faulty thermostat. If the compressor does not start, this indicates a faulty electronic unit or compressor. Contact an authorized service agent. A possible leak in the cooling system, contact an authorized service agent. |
| Compressor makes only short start attempts. | Bad power supply, too low voltage or voltage drop at start attempts. Discharged batteries. | Check cables, terminals and other connections, possible verdigris or corrosion, Clean. Charge batteries, run the engine or connect a battery charger. Voltage must be kept above 11.0 V at start attempts. |
| Compressor runs but no refrigeration generated. | Loss of refrigerant. Leakage in pipes or evaporator. Pipes blocked. | Pressure and leak test. Check for pipe damages. Repair possible leak, evacuate and re-fill refrigerant. (All this to be made by refrigeration specialist). |
| Compressor runs long time but not generating enough cold. | Bad ventilation. Condenser too warm. Cooling fan not working Too much frost on evaporator. Door not closing well. Condenser blocked by dust. | Improve ventilation for compressor. Re-place fan. Defrost. Check/adjust door position and door seal. Clean condenser. |
| Fuse blows. | Wrong fuse size. Faulty electronic unit. | Check fuse, 15 A-12 V / 7,5 A-24 V Exchange electronic unit. |

6.2 Self-Diagnostics

LED (optional) See Figure 6.2 TruckFridge 12VDC 101N0212 ECU Electrical Schematic

A 10mA light emitting diode (LED) (6) can be connected between the terminals + and D. In case the electronic unit records an operational error, the diode will flash a number of times. The number of flashes depends on what kind of operational error was recorded. Each flash will last ¼ second. After the actual number of flashes there will be a delay with no flashes, so that the sequence for each error recording is repeated every 4 seconds.

Diagnostic Procedure

1. Disconnect thin black wire from terminal marked (-).
2. Reconnect to terminal marked (D).
3. Observe the number of flashes of the interior LED light bulb.
4. See Figure 6.2.2: Error Code Summary Table for error code description.
5. Reconnect thin black wire to terminal marked (-).

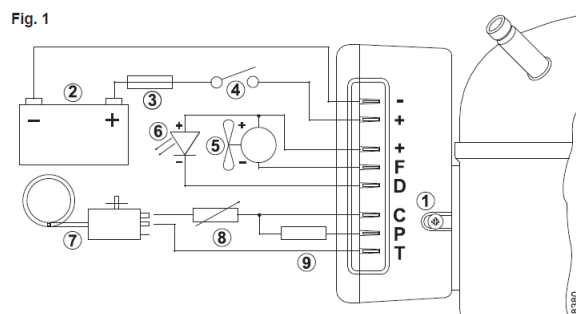

Figure 6.2.1: TruckFridge 12VDC 101N0212 ECU Electrical Schematic

| No. of flashes | Error Type |
|----------------|------------|
|----------------|------------|

TruckFridge Built-in User Manual

| | |
|----------|--|
| 5 | Thermal cut-out of electronic unit (If the refrigeration system has been too heavily loaded, or if the ambient temperature is high, the electronic unit will run too hot). |
| 4 | Minimum motor speed error (If the refrigeration system is too heavily loaded, the motor cannot maintain minimum speed 1,850 rpm). |
| 3 | Motor start error (The rotor is blocked or the differential pressure in the refrigeration system is too high (>5 bar)). |
| 2 | Fan over-current cut-out (The fan loads the electronic unit with more than 1A peak). |
| 1 | Battery protection cut-out (The voltage is outside the cut-out setting) |

Table 6.2.2: Error Code Summary Table

6.3 Thermostat Test / Adjustment

Overview

If the thermostat requires adjustment or is defective the refrigerator fan and compressor may not operate properly. To test the thermostat please follow the following test procedure

Thermostat Test Procedure

6. Disconnect the "Blue" wire from the "T" terminal.
7. Disconnect the single "Brown" wire from the "P" terminal.
8. Reconnect the single "Brown" wire to the "T" terminal
9. If the fan and compressor turn on, the thermostat is defective
10. If the fan and compressor do not turn on, contact Northern Fridge support for service
11. Reconnect the "Blue" wire to the "T" terminal and reconnect single "Brown" wire to the "P" terminal

Fig. 1

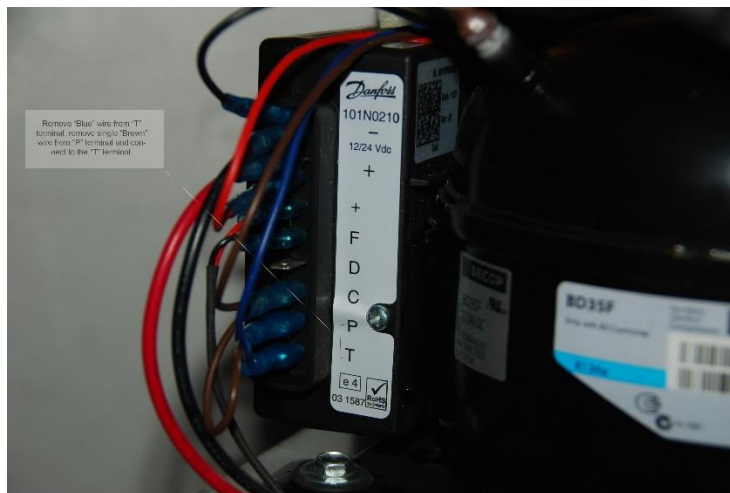
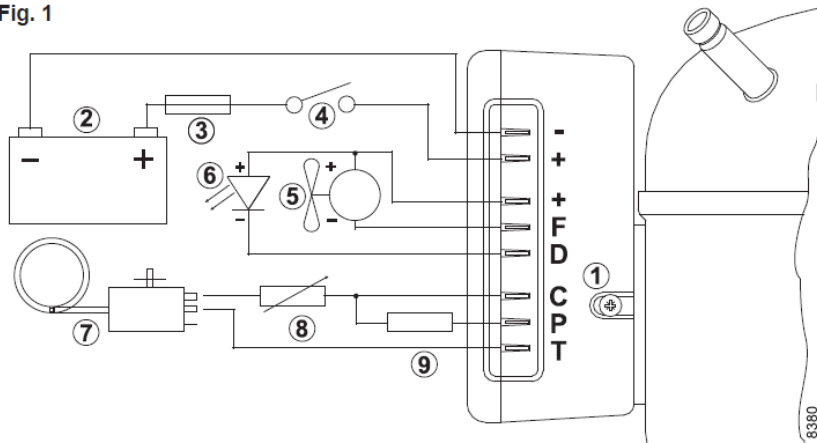

TruckFridge Built-in User Manual

6.3.1 Thermostat Adjustment for TF49, Tf65 and TF130 models

Before attempting to adjust the thermostat, insure that the thermostat is turned off and that power is disconnected from the fridge.

- 1) Remove thermostat knob and lock nut (9/16" deep socket or needle-nose pliers work well). See Fig. 4.
- 2) Open unit and turn thermostat to 0 (off). Unplug the fridge.
- 3) Remove the light assembly. Push down on grey light plunger to release light housing (figure 1). Unplug the two wires (red and black) from the back of the light assembly.
- 4) Remove the thermostat housing. Remove 3 screws under light using a Phillips screwdriver inside the light housing (figure 2).
- 5) Remove the 4th screw using a Phillips screwdriver from the thermostat housing in the back right corner (figure 3). NOTE. This screw is always a pain to remove.
- 6) Pull the thermostat from the housing (figure 5).
- 7) Locate the adjustment screw on the thermostat (figure 6).
- 8) With a sharpie or paint marker put a small mark on the head of the screw and thermostat body (Just so you know where you started).
- 9) Turn the adjustment screw one full turn counter-clockwise. This should allow the fridge to run longer so that it achieves a lower internal temperature.
- 10) Before putting everything back together it is recommended that you put the thermostat knob back on and turn the dial to 5, plug the fridge in and run it for about 24 hours to see if the temperature is where you would like to see it at. If not, you can adjust it safely another ½ turn counter-clockwise and run another 24 hours. If it is still not cooling properly, replace the thermostat (part No. L017). See website under "12V Truck/Van Fridge Accessories" for pricing and availability.
- 11) After completing the thermostat adjustment start at step 6 and do in reverse to reassemble.



Figure 1



Figure 2

TruckFridge Built-in User Manual



Figure 3



Figure 4



Figure 5



Figure 6

TruckFridge Built-in User Manual

7.0 SPECIFICATIONS

Note. If in doubt about the model for your truck, always confirm by measuring the height, width and depth of the cabinet opening before ordering.

Please note that models, prices, and availability is subject to change without obligation or notice.

7.1 Truckfridge Model TF49

| Description | TF49DC | TF49ACDC |
|-----------------------------|--|----------------------|
| Outside Dimensions (inches) | 20.5H x 15"W x 18"D | |
| Inside Dimensions (inches) | 17.5" H x 12.75"W x 16"D | |
| Freezer | 9"W x 3"H x 8.5"D | |
| Total Capacity | 49 litre / 1.73 cu. ft. | |
| Freezer | 8 Liter / .14 Cu.Ft. | |
| Nominal voltage | 12-24Vdc | 12-24Vdc, 110-220Vac |
| Nominal input power | 60 watt/hour (5 amp/hour) | |
| Average power consumption | 40 Amps/24h. (1.7 amp/hour) | |
| In-line fuse | 15A (12VDC), 7.5A (24VDC) | |
| Refrigerant | R134a | |
| Temperature Range | +2°C to -7°C (35°F to 18°F) | |
| Air cooling | Forced with fan | |
| Standard Features | Interior light, adjustable thermostat, (1) wire shelves, (2) door shelves and low voltage cut-out. | |
| Colour | Cabinet (Black); Interior (White); Door Panel (Black Plexiglass) | |
| EMC conformity | Yes | |
| Net weight (lbs) | 35 lbs | |
| Warranty | Two (2) year parts and labour | |

7.2 Truckfridge Model TFDR49DC-BL

| Description | TFDR49DC-BL |
|-----------------------------|---|
| Outside Dimensions (inches) | 20.5H x 15.375 "W x 20.5"D |
| Inside Dimensions (inches) | |
| Freezer | 6.5"H x 11"W x 6.5"D |
| Total Capacity | 49 litre / 1.73 cu. ft. |
| Freezer | 7.33 Liter / .26 Cu.Ft. |
| Nominal voltage | 12-24Vdc |
| Nominal input power | 60 watt/hour (5 amp/hour) |
| Average power consumption | 40 Amps/24h. (1.7 amp/hour) |
| In-line fuse | 15A (12VDC), 7.5A (24VDC) |
| Refrigerant | R134a |
| Temperature Range | +2°C to -7°C (35°F to 18°F) |
| Air cooling | Forced with fan |
| Standard Features | Sliding drawer top opening, separate fridge / freezer compartments, interior light, adjustable thermostat, (2) compartment dividers, low voltage cut-out and installation frame/kit |
| Colour | Cabinet (Black); Interior (White); Door Panel (Black Plexiglass) |
| EMC conformity | Yes |
| Net weight (lbs) | 55 lbs |
| Warranty | Two (2) year parts and labour |

TruckFridge Built-in User Manual

7.3 Truckfridge Model TF65

| Description | TF65DC | TF65ACDC |
|-----------------------------|---|----------------------|
| Outside Dimensions (inches) | 21H x 17.75"W x 18.375"D | |
| Inside Dimensions (inches) | 18" H x 15.675"W x 17"D | |
| Freezer | 9.5"W x 3"H x 8.5"D | |
| Total Capacity | 65 litre / 2.3 cu. ft. | |
| Freezer | 8 Liter / .14 Cu.Ft. | |
| Nominal voltage | 12-24Vdc | 12-24Vdc, 110-220Vac |
| Nominal input power | 60 watt/hour (5 amp/hour) | |
| Average power consumption | 40 Amps/24h. (1.7 amp/hour) | |
| In-line fuse | 15A (12VDC), 7.5A (24VDC) | |
| Refrigerant | R134a | |
| Temperature Range | +2°C to -7°C (35°F to 18°F) | |
| Air cooling | Forced with fan | |
| Standard Features | Interior light, adjustable thermostat, (1) wire shelves, (2) door shelves and low voltage cut-out and installation frame/kit. | |
| Colour | Cabinet (Black); Interior (White); Door Panel (Black Plexiglass) | |
| EMC conformity | Yes | |
| Net weight (lbs) | 40 lbs | |
| Warranty | Two (2) year parts and labour | |

7.4 Truckfridge Model TF130

| Description | TF130DC | TF130ACDC |
|-----------------------------|--|----------------------|
| Outside Dimensions (inches) | 29.5H x 20.25"W x 20.75"D | |
| Inside Dimensions (inches) | 26" H x 18"W x 13.75"D | |
| Freezer | 8"W x 3.5"H x 13.75"D | |
| Total Capacity | 119 litre / 4.2 cu. ft. | |
| Freezer | 6.3 Liter / .22 Cu.Ft. | |
| Nominal voltage | 12-24Vdc | 12-24Vdc, 110-220Vac |
| Nominal input power | 60 watt/hour (5 amp/hour) | |
| Average power consumption | 40 Amps/24h. (1.7 amp/hour) | |
| In-line fuse | 15A (12VDC), 7.5A (24VDC) | |
| Refrigerant | R134a | |
| Temperature Range | +2°C to -7°C (35°F to 18°F) | |
| Air cooling | Forced with fan | |
| Standard Features | Lower pull out drawer, interior light, adjustable thermostat, (3) wire shelves, (1) glass shelf, (3) door shelves, low voltage cut-out and installation frame/kit. | |
| Colour | Cabinet (Black); Interior (White); Door Panel (Black Plexiglass) | |
| EMC conformity | Yes | |
| Net weight (lbs) | 53 lbs | |
| Warranty | Two (2) year parts and labour | |

TruckFridge Built-in User Manual

8.1.1 TF49 Fridge Parts List/Description

| INDEL B P/N | DESCRIPTION |
|-------------|------------------------|
| D001 | Support for Drip Tray |
| D002 | Drip Tray |
| D003 | Frontal Differential |
| D004 | Rear Differential |
| D005 | Shim |
| D006 | Bolt |
| D007 | Evaporator Door |
| E162 | Bolt |
| E191 | Bolt |
| F005 | Handle |
| F008 | Ice Pan |
| F052 | Handle Cap |
| F065 | Pivot |
| F092 | Profile |
| F093 | Grid |
| F094 | Top |
| F100 | Door Panel |
| F134 | Refrigerator Door |
| K071 | Hinge |
| K075 | Pivot Support |
| K077 | Pivot |
| K080 | Upper Bottles Retainer |
| K093 | Lower Bottles Retainer |
| K094 | Metal Retainer |

8.1.2 TF49 Cooling System Parts Diagram

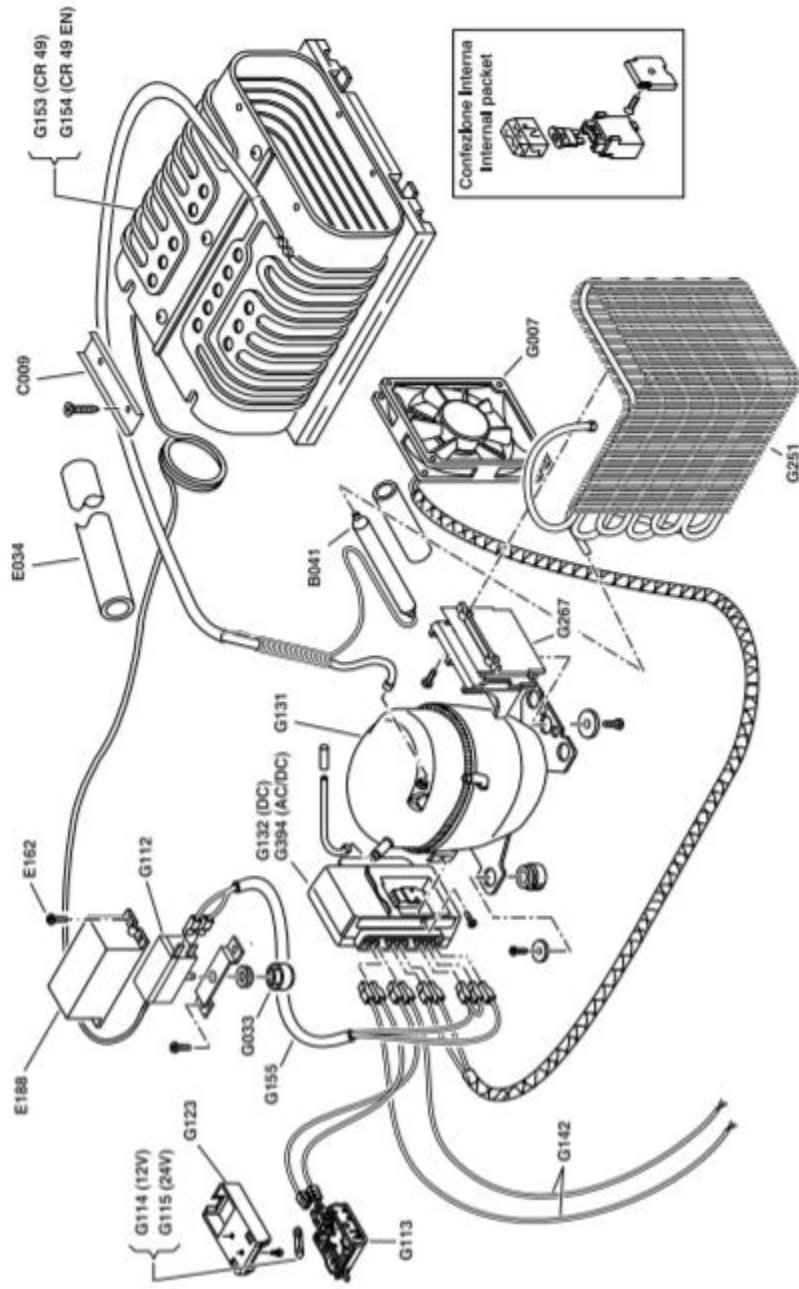

TruckFridge Built-in User Manual

8.1.3 TF49 Cooling System Parts List/Description

| INDEL B P/N | DESCRIPTION |
|-----------------|-----------------------------|
| B041 | Filter |
| C009 | Bracket of Thermostat Bulb |
| E034 | Pipe Protection |
| E162 | Bolt |
| E188 | Thermostat protection Box |
| G007 | Fan |
| G033 | Thermostat Knob |
| G112 | Thermostat |
| G113 | Light Fixture |
| G114 (12V) | Light Bulb |
| G115 (24V) | Light Bulb |
| G123 | Light Bulb Glass |
| G131 | Compressor |
| G132 (DC) | ECU |
| G142 | Thermostat Connection Wire |
| G153 (CR 49) | Evaporator |
| G154 (CR 49 EN) | Evaporator |
| G155 | Thermostat Wires Protection |
| G251 | Condenser |
| G267 | Condenser Support |
| G394 (AC/DC) | ECU |

8.2 TFDR49 Fridge Parts Diagram

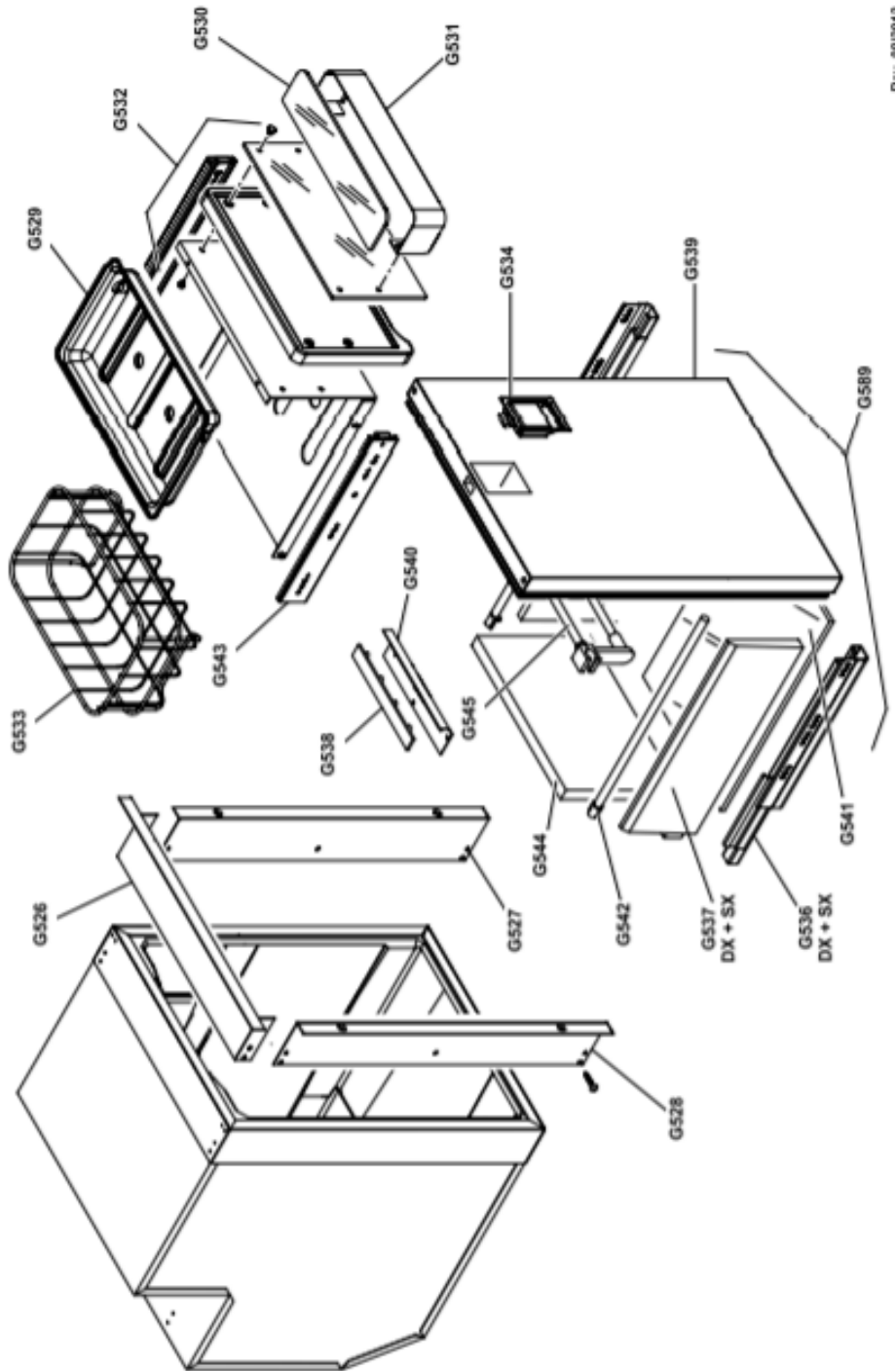

TruckFridge Built-in User Manual

8.2.1 TFDR49 Fridge Parts List/Description

| INDEL B P/N | DESCRIPTION |
|--------------------|-------------------------|
| E073 | Foot Kit |
| F008 | Ice Pan |
| F130 | Handle |
| F170 (INOX DOOR) | Door Flange |
| F235 (GLASS DOOR) | Door Flange |
| F236 (CUSTOM DOOR) | Door Flange |
| F237 | Inox Door |
| F238 | Glass Door |
| F239 | Glass Panel with Handle |
| G529 | DripTray |
| G530 | Balcony Glass |
| G531 | Balcony |
| G533 | Freezer Basket |
| G536 | Drawer Fixing Rail |
| G538 | Display |
| G540 | Escutcheon Display |
| G545 | PartitionElement |
| G585 | Cabinet Basket |
| G587 | Freezer Door |

8.2.2 TFDR49 Cooling System Parts Diagram

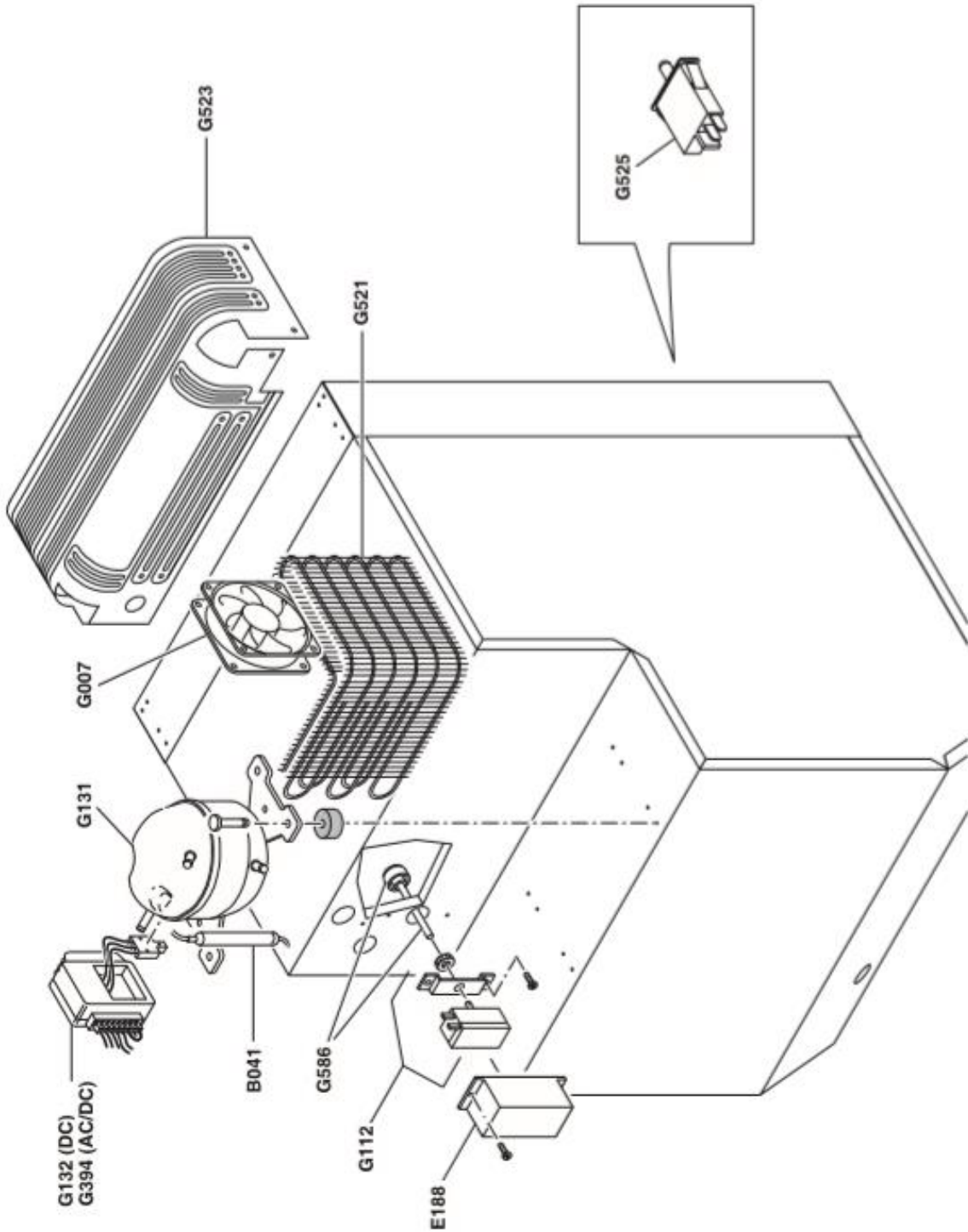

TruckFridge Built-in User Manual

8.2.3 TFDR49 Cooling System Parts List/Description

| INDEL B P/N | DESCRIPTION |
|-------------|----------------|
| B041 | Filter |
| E188 | Thermostat Box |
| G007 | Fan |
| G112 | Thermostat |
| G131 | Compressor |
| G132 | ECU (DC) |
| G251 | Condenser |
| G394 | ECU (AC/DC) |
| G521 | Condenser |
| G523 | Evaporator |
| G525 | Light Button |
| G586 | ThermostatKnob |

8.3 TF65 Fridge Parts Diagram

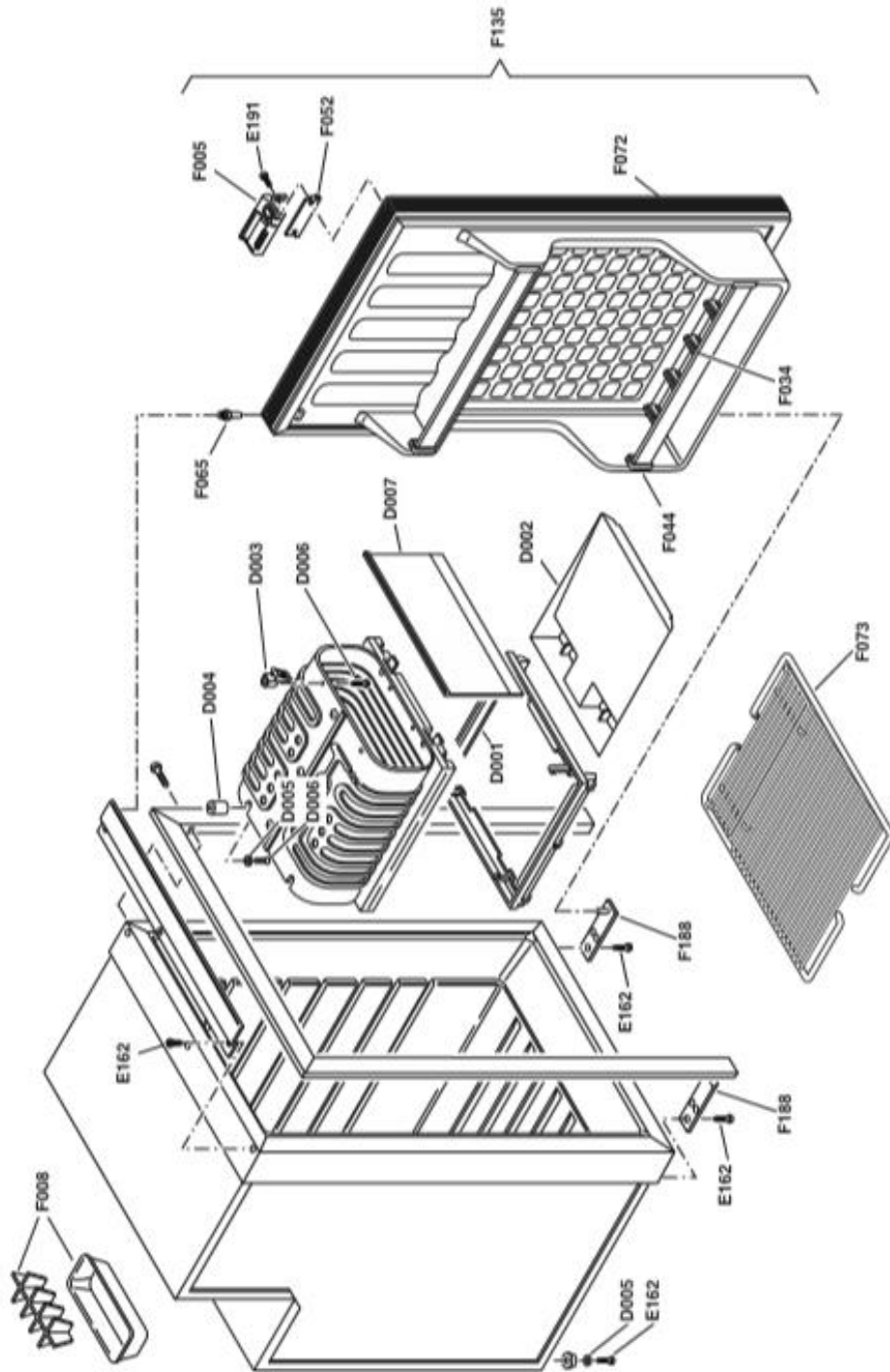

TruckFridge Built-in User Manual

8.3.1 TF65 Fridge Parts List/Description

| INDEL B P/N | DESCRIPTION |
|-------------|-----------------------|
| D001 | Support for Drip Tray |
| D002 | Drip Tray |
| D003 | Frontal Differential |
| D004 | Rear Differential |
| D005 | Shim |
| D006 | Bolt |
| D007 | Freezer Door |
| E162 | Bolt |
| E191 | Bolt |
| F005 | Handle |
| F008 | Ice Pan |
| F034 | Partition Element |
| F044 | Balcony Support |
| F052 | Handle Cap |
| F065 | Pivot |
| F072 | Profile |
| F073 | Grid |
| F188 | Hinge |

8.3.2 TF65 Cooling System Parts Diagram

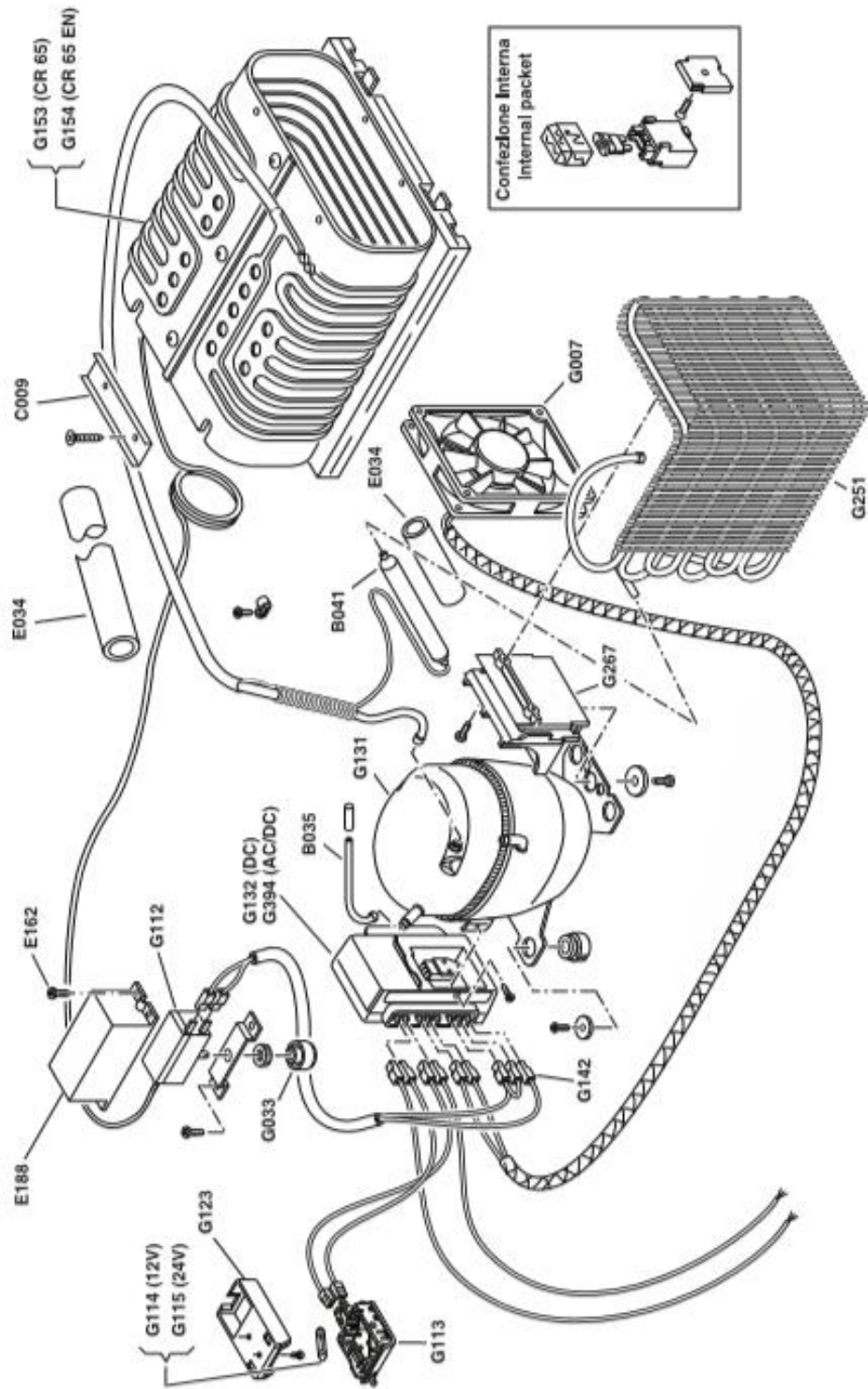

TruckFridge Built-in User Manual

8.3.3 TF65 Cooling System Parts List/Description

| INDEL B P/N | DESCRIPTION |
|-----------------|----------------------------|
| B035 | Compressor Pipe |
| B041 | Filter |
| C009 | Bracket of Thermostat Bulb |
| E034 | Pipe Protection |
| E162 | Bolt |
| E188 | Thermostat protection Box |
| G007 | Fan |
| G033 | Thermostat Knob |
| G112 | Thermostat |
| G113 | Light Fixture |
| G114 (12V) | Light Bulb |
| G115 (24V) | Light Bulb |
| G123 | Light Bulb Glass |
| G131 | Compressor |
| G132 (DC) | ECU |
| G142 | Thermostat Connection Wire |
| G153 (CR 65) | Evaporator |
| G154 (CR 65 EN) | Evaporator |
| G251 | Condenser |
| G267 | Condenser Support |
| G394 (AC/DC) | ECU |

8.4 TF130 Fridge Parts Diagram

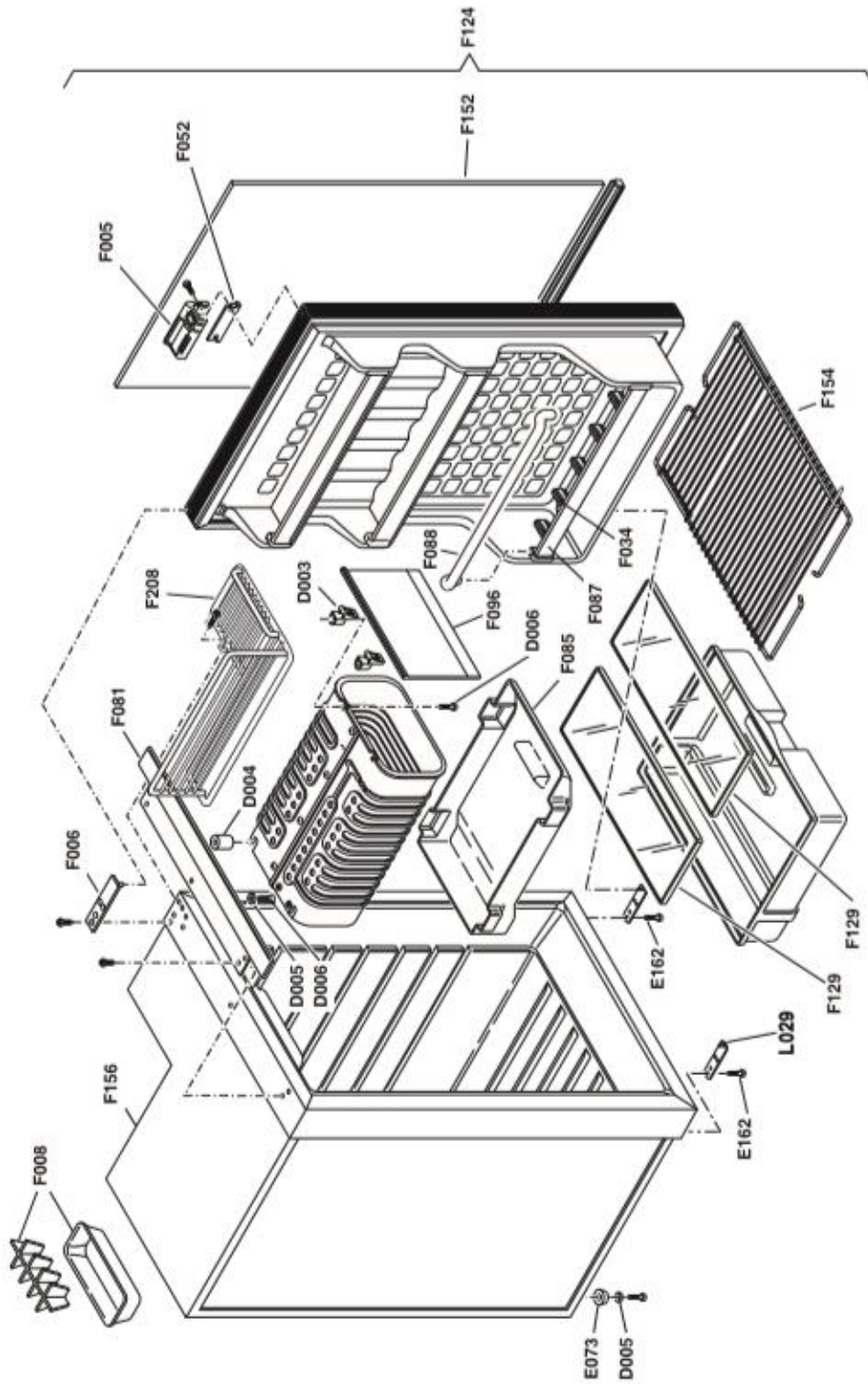

TruckFridge Built-in User Manual

8.4.1 TF130 Fridge Parts List/Description

| INDEL B P/N | DESCRIPTION |
|-------------|---------------------------|
| D003 | Frontal Differential |
| D004 | Rear Differential |
| D005 | Shim |
| D006 | Bolt |
| E073 | Feet |
| E162 | Bolt |
| F005 | Handle |
| F006 | Upper Hinge |
| F008 | Ice Pan |
| F034 | Bottles Partition Element |
| F052 | Handle Cap |
| F081 | Upper Pivot Support |
| F085 | Drip Tray |
| F087 | Bottles Retainer |
| F088 | Metal Retainer |
| F096 | Evaporator Door |
| F124 | Door (complete) |
| F129 | Glass Shelf |
| F152 | Door Panel |
| F156 | Cabinet |
| F208 | Grid |
| L029 | Hinge |
| L056 | Grid |

8.4.2 TF130 Cooling System Parts Diagram

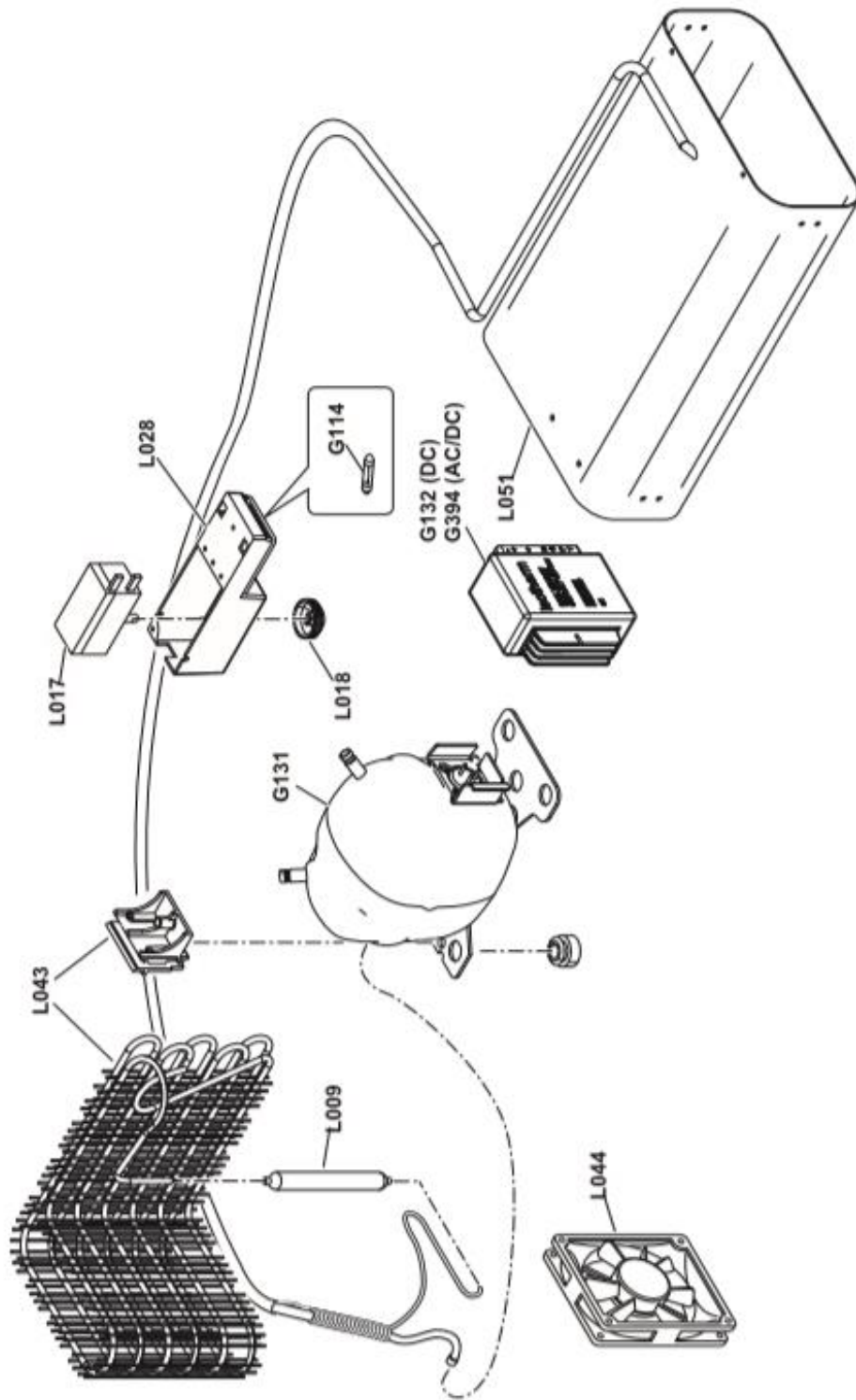

TruckFridge Built-in User Manual

8.4.3 TF130 Cooling System Parts List/Description

| INDEL B P/N | DESCRIPTION |
|--------------|----------------|
| G114 (12V) | Light Bulb |
| G115 (24V) | Light Bulb |
| G131 | Compressor |
| G132 (DC) | ECU |
| G394 (AC/DC) | ECU |
| L009 | Filter |
| L017 | Thermostat |
| L018 | ThermostatKnob |
| L028 | Ceiling Light |
| L043 | Condenser |
| L044 | Fan |
| L051 | Evaporator |

8.5 Danfoss/Secop BD35F-HD Compressor Specifications



**BD35F-HD
Heavy Duty
Direct Current Compressor
R134a, 12-24V DC**

General

| | |
|---|----------------------------|
| Code number (without electronic units) | 101Z0206 |
| Electronic unit - Standard | 101N0210, 30 pcs: 101N0211 |
| Approval for compressor - electronic unit combination | UL |
| Additional approvals | e4, C-Tick |
| Compressors on pallet | 150 |

Application

| | |
|---|------------------------|
| Application | LBP/MBP/HBP |
| Evaporating temperature °C | -30 to 0 (10) |
| Voltage range VDC | 9.6 - 17 / 21.3 - 31.5 |
| Max. condensing temperature continuous (short) °C | 60 (70) |
| Max. winding temperature continuous (short) °C | 125 (135) |

Cooling requirements

| Application | LBP | MBP | HBP |
|-------------|-----|-----|-----|
| 32°C | S | S | S |
| 38°C | S | S | S |
| 43°C | S | S | S |

Remarks on application:

HD (Heavy Duty) version of the BD35F which can handle extreme vibrations.

Fan cooling F₁ depending on application and speed.

For more info please contact: mobile@secop.com.

Motor

| | |
|-----------------------------------|----------------|
| Motor type | variable speed |
| Resistance, all 3 windings (25°C) | Ω 2.2 |

Design

| | | |
|-------------------------------------|-----------------|-----------------|
| Displacement | cm ³ | 2.00 |
| Oil quantity (type) | cm ³ | 150 (polyester) |
| Maximum refrigerant charge | g | 300 |
| Free gas volume in compressor | cm ³ | 870 |
| Weight - Compressor/Electronic unit | kg | 4.3/0.27 |

Standard battery protection settings (refer to 101N0xxx instructions for optional settings)

| | | |
|-------------|------|------|
| Voltage | 12V | 24V |
| Cut out VDC | 10.4 | 22.8 |
| Cut in VDC | 11.7 | 24.2 |

Dimensions

| | | | |
|---------------------|--------------------------|---------------------------|--------------------------|
| Height | mm | A | 137 |
| | | B | 135 |
| | | B1 | 128 |
| | | B2 | 73 |
| Suction connector | location/I.D. mm angle | C | 6.2 40° |
| | | material comment | Cu-plated steel Al cap |
| Process connector | location/I.D. mm angle | D | 6.2 45° |
| | | material comment | Cu-plated steel Al cap |
| Discharge connector | location/I.D. mm angle | E | 5.0 21° |
| | | material comment | Cu-plated steel Al cap |
| Connector tolerance | I.D. mm | ±0.09, on 5.0 +0.12/+0.20 | |
| Remarks: | | | |

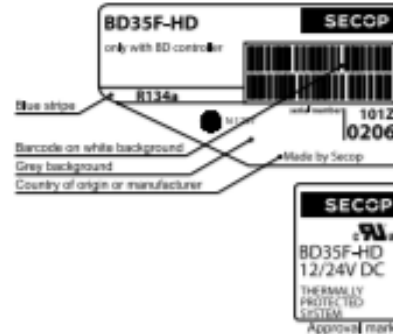

- S = Static cooling normally sufficient
- O = Oil cooling
- F₁ = Fan cooling 1.5 m/s
(compressor compartment temperature equal to ambient temperature)
- F₂ = Fan cooling 3.0 m/s necessary
- SG = Suction gas cooling normally sufficient
- = not applicable in this area

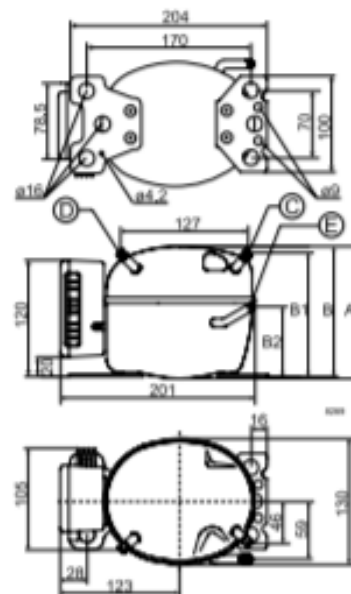

TruckFridge Built-in User Manual

8.5 (Cont'd): Danfoss/Secop BD35F-HD Compressor Specifications

| Capacity (EN 12900 Household/CECOMAF) | | | | | | | | | | 12V DC, static cooling | | watt |
|---------------------------------------|------|------|-------|------|------|------|------|------|-----|------------------------|-----|------|
| rpm \ °C | -30 | -25 | -23.3 | -20 | -15 | -10 | -5 | 0 | 5 | 7.2 | 10 | 15 |
| 2,000 | 16.0 | 23.8 | 26.7 | 32.9 | 43.7 | 56.5 | 71.8 | 89.8 | 111 | 121 | 136 | |
| 2,500 | 18.8 | 29.9 | 33.9 | 41.9 | 55.4 | 71.1 | 89.8 | 112 | 139 | 152 | | |
| 3,000 | 22.4 | 32.9 | 37.1 | 46.1 | 62.5 | 82.2 | 106 | 133 | | | | |
| 3,500 | 27.0 | 35.9 | 40.2 | 50.3 | 69.8 | 93.9 | 122 | | | | | |

| Capacity (ASHRAE LBP) | | | | | | | | | | 12V DC, static cooling | | watt |
|-----------------------|------|------|-------|------|------|------|------|-----|-----|------------------------|-----|------|
| rpm \ °C | -30 | -25 | -23.3 | -20 | -15 | -10 | -5 | 0 | 5 | 7.2 | 10 | 15 |
| 2,000 | 20.0 | 29.8 | 33.4 | 41.2 | 54.6 | 70.6 | 89.7 | 112 | 139 | 152 | 169 | |
| 2,500 | 23.6 | 37.5 | 42.4 | 52.4 | 69.2 | 88.8 | 112 | 140 | 173 | 190 | | |
| 3,000 | 28.1 | 41.3 | 46.5 | 57.9 | 78.2 | 103 | 132 | 166 | | | | |
| 3,500 | 33.9 | 45.1 | 50.5 | 63.1 | 87.3 | 117 | 153 | | | | | |

| Power consumption | | | | | | | | | | 12V DC, static cooling | | watt |
|-------------------|------|------|-------|------|------|------|------|------|------|------------------------|------|------|
| rpm \ °C | -30 | -25 | -23.3 | -20 | -15 | -10 | -5 | 0 | 5 | 7.2 | 10 | 15 |
| 2,000 | 17.7 | 22.9 | 24.6 | 27.7 | 32.2 | 36.7 | 41.3 | 46.2 | 51.6 | 54.3 | 57.8 | |
| 2,500 | 22.1 | 29.7 | 32.0 | 36.3 | 42.4 | 48.1 | 53.8 | 59.7 | 66.1 | 69.1 | | |
| 3,000 | 29.3 | 34.6 | 36.7 | 41.2 | 48.7 | 56.5 | 64.5 | 72.0 | | | | |
| 3,500 | 34.5 | 41.3 | 43.8 | 48.9 | 57.3 | 66.2 | 75.4 | | | | | |

| Current consumption (for 24V applications the following must be halved) | | | | | | | | | | | | A |
|---|-----|-----|-------|-----|-----|-----|-----|-----|-----|-----|-----|----|
| rpm \ °C | -30 | -25 | -23.3 | -20 | -15 | -10 | -5 | 0 | 5 | 7.2 | 10 | 15 |
| 2,000 | 1.4 | 1.9 | 2.0 | 2.3 | 2.7 | 3.1 | 3.4 | 3.8 | 4.3 | 4.5 | 4.8 | |
| 2,500 | 1.8 | 2.5 | 2.7 | 3.0 | 3.5 | 4.0 | 4.5 | 5.0 | 5.5 | 5.8 | | |
| 3,000 | 2.4 | 2.9 | 3.1 | 3.4 | 4.0 | 4.7 | 5.3 | 6.0 | | | | |
| 3,500 | 2.9 | 3.4 | 3.6 | 4.1 | 4.8 | 5.5 | 6.3 | | | | | |

| COP (EN 12900 Household/CECOMAF) | | | | | | | | | | 12V DC, static cooling | | W/W |
|----------------------------------|------|------|-------|------|------|------|------|------|------|------------------------|------|-----|
| rpm \ °C | -30 | -25 | -23.3 | -20 | -15 | -10 | -5 | 0 | 5 | 7.2 | 10 | 15 |
| 2,000 | 0.90 | 1.04 | 1.09 | 1.19 | 1.36 | 1.54 | 1.74 | 1.94 | 2.15 | 2.24 | 2.35 | |
| 2,500 | 0.85 | 1.01 | 1.06 | 1.15 | 1.31 | 1.48 | 1.67 | 1.88 | 2.10 | 2.20 | | |
| 3,000 | 0.76 | 0.95 | 1.01 | 1.12 | 1.28 | 1.45 | 1.64 | 1.85 | | | | |
| 3,500 | 0.78 | 0.87 | 0.92 | 1.03 | 1.22 | 1.42 | 1.62 | | | | | |

| COP (ASHRAE LBP) | | | | | | | | | | 12V DC, static cooling | | W/W |
|------------------|------|------|-------|------|------|------|------|------|------|------------------------|------|-----|
| rpm \ °C | -30 | -25 | -23.3 | -20 | -15 | -10 | -5 | 0 | 5 | 7.2 | 10 | 15 |
| 2,000 | 1.13 | 1.30 | 1.36 | 1.49 | 1.70 | 1.93 | 2.18 | 2.44 | 2.70 | 2.81 | 2.95 | |
| 2,500 | 1.07 | 1.26 | 1.33 | 1.45 | 1.64 | 1.86 | 2.10 | 2.36 | 2.64 | 2.77 | | |
| 3,000 | 0.96 | 1.19 | 1.27 | 1.41 | 1.61 | 1.83 | 2.06 | 2.32 | | | | |
| 3,500 | 0.98 | 1.09 | 1.15 | 1.29 | 1.53 | 1.78 | 2.03 | | | | | |

| Test conditions with electronic unit | | EN 12900/CECOMAF | ASHRAE LBP |
|--------------------------------------|----------------------|------------------|------------|
| Condensing temperature | 101N0212 101N0650 | 55°C | 54.4°C |
| Ambient temperature | | 32°C | 32°C |
| Suction gas temperature | | 32°C | 32°C |
| Liquid temperature | | no subcooling | 32°C |

| Accessories for BD35F-HD.2 | | Code number |
|----------------------------|-----------------------|-----------------|
| Bolt joint for one comp. | Ø:16 mm | 118-1917 |
| Bolt joint in quantities | Ø:16 mm | 118-1918 |
| Snap-on in quantities | Ø:16 mm | 118-1919 |
| Remote kit (without cable) | | 105N9210 |
| One Wire/LIN gateway | | 105N9501 |
| Automobile fuse, DIN 7258 | 12V: 15A 24V: 7.5 A | Not deliverable |
| Main switch | min. 20A | from Secop |

Compressor speed

| Electronit unit | Resistor (R1) [Ω] | Motor speed | Control circuit |
|-----------------|-------------------|-------------|-----------------|
| Code number | calculated values | [rpm] | current [mA] |
| 101N0210 | 0 | 2,000 | 5 |
| | 277 | 2,500 | 4 |
| | 692 | 3,000 | 3 |
| | 1523 | 3,500 | 2 |

wire Dimensions DC

| Size | | Max. length* 12V operation | | Max. length* 24V operation | |
|---------------|---------|----------------------------|-------|----------------------------|-------|
| Cross section | AWG | [m] | [ft.] | [m] | [ft.] |
| [mm²] | [Gauge] | | | | |
| 2.5 | 12 | 2.5 | 8 | 5 | 16 |
| 4 | 12 | 4 | 13 | 8 | 26 |
| 6 | 10 | 6 | 20 | 12 | 39 |
| 10 | 8 | 10 | 33 | 20 | 66 |

*Length between battery and electronic unit

8.6 101N0212 ECU 12VDC Specifications for BD35F-HD

ENGINEERING
TOMORROW



Instructions

Electronic unit BD35F/50F/35K compressors
101N0212 & 101N0650, 12-24V DC

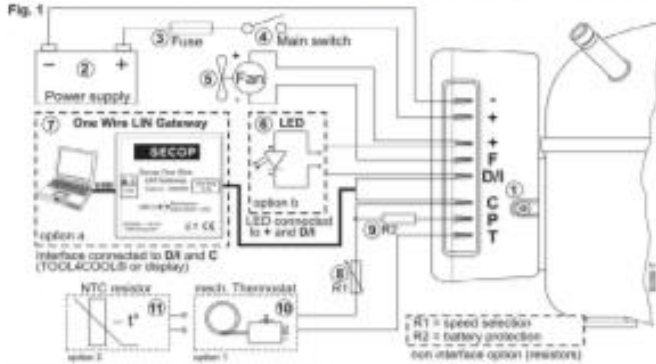

Wire Dimensions DC

| Cross section [mm ²] | Size AWG [Gauge] | Max. length* 12V operation | | Max. length* 24V operation | |
|-------------------------------------|------------------------|-------------------------------|------|-------------------------------|------|
| | | [m] | [ft] | [m] | [ft] |
| 2.5 | 13 | 2.5 | 8 | 5 | 16 |
| 4 | 12 | 4 | 13 | 8 | 26 |
| 6 | 10 | 6 | 20 | 12 | 39 |
| 10 | 8 | 10 | 33 | 20 | 66 |

Fig. 2 *Length between battery and electronic unit

Standard battery protection settings

| 12V cut-out [V] | 12V cut-in [V] | 24V cut-out [V] | 24V cut-in [V] |
|-----------------|----------------|-----------------|----------------|
| 10.4 | 11.7 | 22.8 | 24.2 |

Fig. 3

Optional battery protection settings Fig. 4

| Resistor (8) kΩ | 12V cut-out [V] | 12V cut-in [V] | 12V max. [V] | 24V cut-out [V] | 24V cut-in [V] | 24V max. [V] |
|-----------------|-----------------|----------------|--------------|-----------------|----------------|--------------|
| 0 | 9.6 | 10.9 | 17.0 | 21.3 | 22.7 | 31.5 |
| 1.6 | 9.7 | 11.0 | 17.0 | 21.5 | 22.9 | 31.5 |
| 2.4 | 9.9 | 11.1 | 17.0 | 21.6 | 23.2 | 31.5 |
| 3.6 | 10.0 | 11.3 | 17.0 | 22.0 | 23.4 | 31.5 |
| 4.7 | 10.1 | 11.4 | 17.0 | 22.3 | 23.7 | 31.5 |
| 6.2 | 10.2 | 11.5 | 17.0 | 22.5 | 23.9 | 31.5 |
| 11 | 10.5 | 11.8 | 17.0 | 23.0 | 24.5 | 31.5 |
| 14 | 10.6 | 11.9 | 17.0 | 23.3 | 24.7 | 31.5 |
| 16 | 10.8 | 12.0 | 17.0 | 23.6 | 25.0 | 31.5 |
| 24 | 10.9 | 12.2 | 17.0 | 23.8 | 25.2 | 31.5 |
| 33 | 11.0 | 12.3 | 17.0 | 24.1 | 25.5 | 31.0 |
| 47 | 11.1 | 12.4 | 17.0 | 24.3 | 25.7 | 31.5 |
| 82 | 11.3 | 12.5 | 17.0 | 24.6 | 26.0 | 31.5 |
| 220 | 9.8 | 10.9 | | | | 31.9 |

Compressor speed

| Electronic unit | Resistor (R1) [Ω] | Motor speed values [rpm] | Control circuit current [mA] |
|-----------------|-------------------|--------------------------|------------------------------|
| Code number | calculated values | | |
| | 0 | 2,000 | 5 |
| 101N0212 | 277 | 2,500 | 4 |
| | 692 | 3,000 | 3 |
| 101N0650 | 1523 | 3,500 | 2 |

Fig. 5

The electronic unit is a dual voltage device. This means that the same unit can be used in both 12V and 24V power supply systems. Maximum voltage is 17V for a 12V system and 31.5V for a 24V power supply system. Max. ambient temperature is 55°C. The electronic unit has a built-in thermal protection which is actuated and stops compressor operation if the electronic unit temperature gets too high.

Installation (Fig.1)

Connect the terminal plug from the electronic unit to the compressor terminal. Mount the electronic unit on the compressor by snapping the cover over the screw head (1).

Power supply

The electronic unit must always be connected directly to the battery poles (2). The electronic unit is protected against reverse battery connection. A fuse (3) must be mounted in the cable as close to the battery as possible. 15A fuse for 12V and 7.5A fuse for 24V circuits are recommended. If a main switch (4) is used, it should be rated to a current of min. 20A.

The wire dimensions in Fig. 2 must be observed. Avoid extra junctions in the power supply system to prevent voltage drop from affecting the battery protection setting.

Battery protection

The compressor stops and restarts according to the voltage measured on the + and - terminals of the electronic unit. The standard settings appear from Fig. 3. Other settings (Fig. 4) are optional if a R2 resistor (8) is connected between terminals C and P. In solar applications without a battery a 220 kΩ resistor is recommended.

Thermostat and speed selection

Either an NTC (electrical thermostat, 11) or a mechanical thermostat (10) can be connected between the terminals C and T.

If an NTC is used, the set point and speed can be set via a communication interface between terminals C and D/I.

If a mechanical thermostat is used without any R1 resistor (8), the compressor will run with a fixed speed of 2,000 rpm. Other fixed compressor speeds in the range between 2,000 and 3,500 rpm can be obtained when a resistor (8) is installed to adjust the current (mA) of the control circuit. Resistor values for various motor speeds appear from Fig. 5.

Fan (optional)

A fan (5) can be connected between the terminals + and F. A 12V fan must be used for both 12V and 24V power supply systems. The fan output can supply a continuous current of 0.5Aavg. A higher current draw is allowed for 2 seconds during start.

Communication interface (option a)

A PC can be connected through the manufactured by Secop for Danfoss One Wire/LIN Gateway (7) to the communication interface between terminal D/I and C. The software TOOL4CODE™ allows you to create different settings and reads out several measurements. Settings can be copied from one unit to another in mass production. Alternatively a customer specific controller (e.g. display) can be connected to adjust the settings like set point and speed during operation.

LED (option b)

A 10mA light emitting diode (LED) (6) can be connected between the terminals + and D/I.

In case the electronic unit records an operational error, the diode will flash a number of times. The number of flashes depends on what kind of operational error was recorded. Each flash will last 1/2 second. After the actual number of flashes there will be a delay with no flashes, so that the sequence for each error recording is repeated every 4 seconds.

Operational errors

| Error code or LED flashes | Error type |
|---------------------------|---|
| | Can be read out in the software TOOL4CODE |
| 6 | Thermostat failure (If the NTC thermostat is short circuit or has no connection) |
| 5 | Thermal cut-out of electronic unit (If the refrigeration system has been too heavily loaded, or if the ambient temperature is high, the electronic unit will run too hot) |
| 4 | Minimum motor speed error (If the refrigeration system is too heavily loaded, the motor cannot maintain minimum speed at approximately 1.850 rpm) |
| 3 | Motor start error (The rotor is blocked or the differential pressure in the refrigeration system is too high (>5 bar)) |
| 2 | Fan over-current cut-out (The fan loads the electronic unit with more than 0.5Aavg) |
| 1 | Battery protection cut-out (The voltage is outside the cut-out setting) |

TruckFridge Built-in User Manual

8.6.1 TruckFridge 101N0212 ECU 12VDC Wiring Diagram

TruckFridge 12VDC 101N0212 ECU Electrical

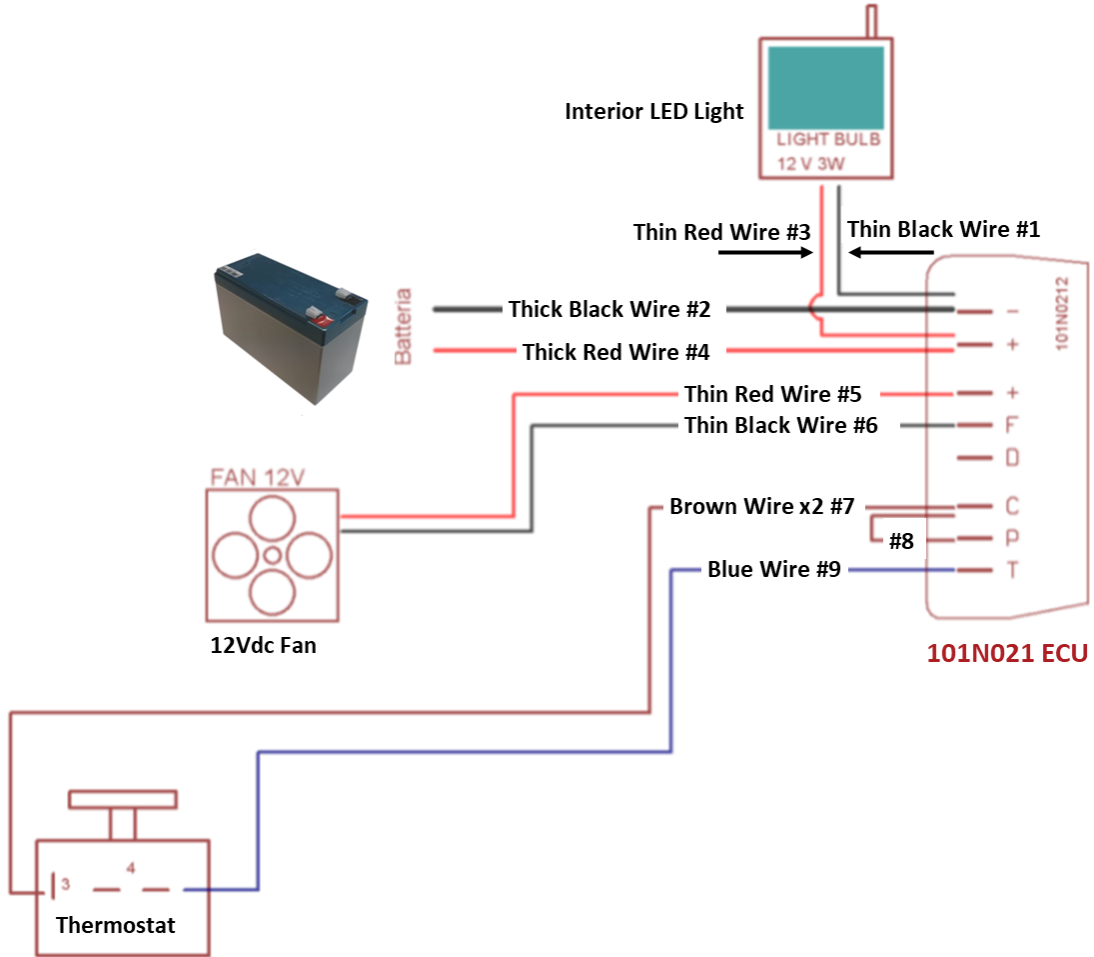

8.7 TruckFridge 101N0500 ECU 12VDC, 110VAC Specifications

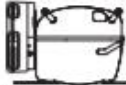

Instructions

Electronic Unit for BD35/BD50F Compressors,
101N0500, 12/24V DC & 100-240V AC 50/60Hz



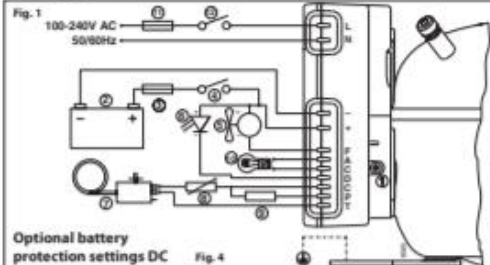

Optional battery protection settings DC Fig. 4

| Resistor (9) kΩ | 12V cut-out V | 12V cut-in V | 12V max. Voltage | 24V cut-out V | 24V cut-in V | 24V max. Voltage |
|-----------------|---------------|--------------|------------------|---------------|--------------|------------------|
| 0 | 9.6 | 10.9 | 17.0 | 21.3 | 22.7 | 31.5 |
| 1.6 | 9.7 | 11.0 | 17.0 | 21.5 | 22.9 | 31.5 |
| 2.4 | 9.9 | 11.1 | 17.0 | 21.8 | 23.2 | 31.5 |
| 3.6 | 10.0 | 11.3 | 17.0 | 22.0 | 23.4 | 31.5 |
| 4.7 | 10.1 | 11.4 | 17.0 | 22.3 | 23.7 | 31.5 |
| 6.2 | 10.2 | 11.5 | 17.0 | 22.5 | 23.9 | 31.5 |
| 8.2 | 10.4 | 11.7 | 17.0 | 22.8 | 24.2 | 31.5 |
| 11 | 10.5 | 11.8 | 17.0 | 23.0 | 24.5 | 31.5 |
| 14 | 10.6 | 11.9 | 17.0 | 23.3 | 24.7 | 31.5 |
| 18 | 10.8 | 12.0 | 17.0 | 23.6 | 25.0 | 31.5 |
| 24 | 10.9 | 12.2 | 17.0 | 23.8 | 25.2 | 31.5 |
| 33 | 11.0 | 12.3 | 17.0 | 24.1 | 25.5 | 31.5 |
| 47 | 11.1 | 12.4 | 17.0 | 24.3 | 25.7 | 31.5 |
| 82 | 11.3 | 12.5 | 17.0 | 24.6 | 26.0 | 31.5 |
| 220 | 9.6 | 10.9 | | | | 31.5 |

Wire dimensions DC

| Size AWG | Cross section mm ² | Max length* 12V DC operation | | Max length* 24V DC operation | |
|----------|-------------------------------|------------------------------|-----|------------------------------|----|
| | | ft. | m | ft. | m |
| 12 | 2.5 | 8 | 2.5 | 16 | 5 |
| 12 | 4 | 13 | 4 | 26 | 8 |
| 10 | 6 | 20 | 6 | 39 | 12 |
| 8 | 10 | 33 | 10 | 66 | 20 |

*Length between battery and electronic unit

Wire dimensions AC
Cross section min. 0.75 mm² or AWG 18

Standard battery protection settings DC

| 12V cut-out V | 12V cut-in V | 24V cut-out V | 24V cut-in V |
|---------------|--------------|---------------|--------------|
| 10.4 | 11.7 | 22.8 | 24.2 |

Compressor speed

| Electronic unit | Resistor (8) Ω (calculated) | Motor speed rpm | Contr. circ. current mA |
|-----------------|-----------------------------|-----------------|-------------------------|
| 101N0500 | 0 | 2,000 | 5 |
| | 277 | 2,500 | 4 |
| | 692 | 3,000 | 3 |
| | 1523 | 3,500 | 2 |

ENGLISH

The electronic unit is a multi voltage device. It can be used in both 12V/24V DC and 100-240V AC 50/60Hz power supply systems. Max. voltage is 17V DC for a 12V DC system and 31.5V DC for a 24V DC power supply system. Max. voltage is 265V AC and min. 85V AC for an AC power supply system. Max. ambient temperature is 55°C. The electronic unit has a built-in thermal protection which is actuated and stops the compressor operation if the electronic unit temperature becomes too high (100°C / 212°F on the PCB). **Power consumption is limited to 100W. See datasheet BD50F for details.**

Installation (Fig. 1)
Connect the terminal plug from the electronic unit to the compressor terminal. Mount the electronic unit on the compressor by snapping the cover over the screw head (1).

Power supply (Fig. 1)
DC: The electronic unit must always be connected directly to the battery poles (2). Connect the plus to + and the minus to -, otherwise the electronic unit will not work. The electronic unit is protected against reverse battery connection.
For protection of the installation, a fuse (3) must be mounted in the + cable as close to the battery as possible. It is recommended to use 15A fuses for 12V and 7.5A fuses for 24V circuits. If a main switch (4) is used, it should be rated to a current of min. 20A. The wire dimensions in Fig. 2 must be observed. Avoid extra junctions in the power supply system to prevent voltage drop from affecting the battery protection setting.
AC: The wires must be connected to the terminals marked L and N on the electronic unit. Nominal voltages from 100 to 240 VAC 50/60Hz. Upper safety cut-out limit = 270V AC and lower limit 80V AC. A 4A fuse (1) must be mounted in the live (L) cable to protect the installation.

if a main switch (12) is used, it should be rated to a current of min. 6A. The wire dimensions must be min. 0.75 mm² or AWG 18.
NB: Earth connection can be used if required.
General: Both the AC and the DC power supply can be connected to the electronic unit at the same time. In this case, AC will be preferred power supply source. If the AC power supply is disconnected or drop below 85V AC on a 12V DC supply system, a time delay of 1 min. will be activated before the compressor continues on DC power supply. If AC power supply is re-established there will be no delay in compressor operation.

Battery protection (Fig. 1)
The compressor is stopped and re-started again according to the decided voltage limits measured on the + and - terminals of the electronic unit. The standard settings for 12V and 24V power supply systems appear from Fig. 3.
Other settings are optional if a connection which includes a resistor (9) is established between terminals C and P. See manual.

Thermostat (Fig. 1)
The thermostat (7) is connected between the terminals C and T. Without any resistor in the control circuit, the compressor will run with a fixed speed of 2,000 rpm when the thermostat is switched on. Other fixed compressor speeds in the range between 2,000 and 3,500 rpm can be obtained when a resistor (8) is installed to adjust the current (mA) of the control circuit. Resistor values for various motor speeds appear from Fig. 5.

Fan (optional, Fig. 1)
A fan (5) can be connected between the terminals + and F. Connect the plus to + and the minus to F. Since the output voltage between the terminals + and F is always regulated to 12V, a 12V fan must be used for both 12V and 24V power supply systems. The fan output can supply a continuous current of 0.5A. A higher current draw is allowed for 2 seconds during start.

Lamp (optional, Fig. 1)
A 12V DC 5 Watt lamp (10) can be connected between the terminals A and C. The output voltage between the terminals A and C is always regulated to 12V DC. A 12V DC lamp must be used for both 12V and 24V power supply systems. The lamp output can supply a continuous current of 0.5A.

LED (optional, Fig. 1)
A 10mA light emitting diode (LED) (6) can be connected between the terminals + and D. If the electronic unit records an operational error, the diode will flash a number of times. The number of flashes depends on what kind of operational error was recorded. Each flash will last 1/4 second. After the actual number of flashes there will be a delay with no flashes, so that the sequence for each error recording is repeated every 4 seconds.

| Number of flashes | Error type |
|-------------------|---|
| 5 | Thermal cut-out of electronic unit (If the refrigeration system has been too heavily loaded or if the ambient temperature is high, the electronic unit will run too hot). |
| 4 | Minimum motor speed error (If the refrigeration system is too heavily loaded, the motor cannot maintain minimum speed 1,800 rpm). |
| 3 | Motor start error (The motor is blocked or the differential pressure in the refrigeration system is too high (>5 bar)). |
| 2 | Fan over-current cut-out (The fan loads the electronic unit with more than 1A). |
| 1 | Battery protection cut-out (The voltage is outside the cut-out setting). |

Visit our Homepage: compressors.danfoss.com

1/2 DEHC.E1.100.G3.02/520N0232 09-2008

TruckFridge Built-in User Manual

8.7.1 TruckFridge 101N0500 ECU 12VDC, 110VAC Wiring Diagram

TruckFridge 12VDC, 110VAC 101n0500 ECU

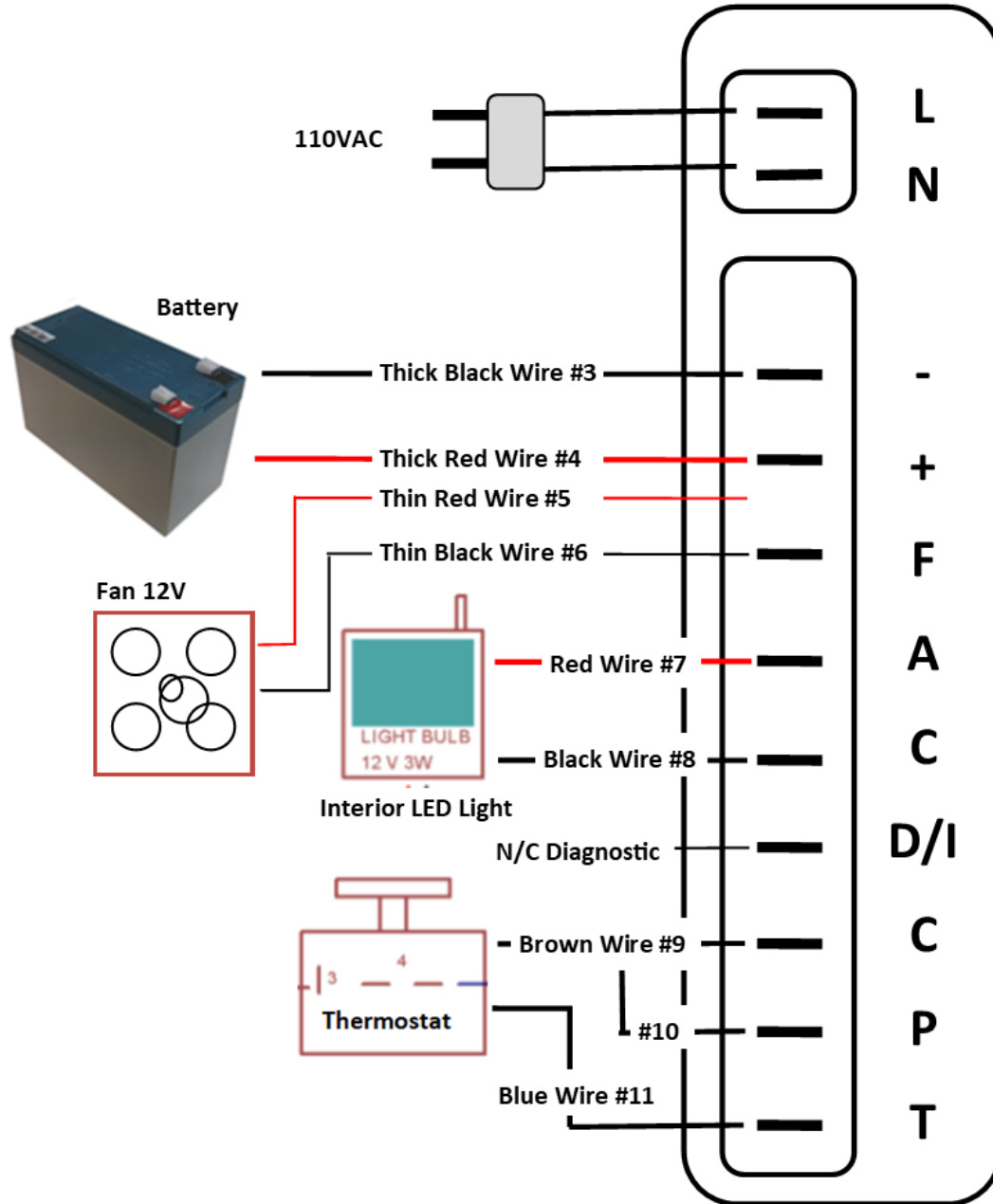

8.8 TF49 Dimensional Diagram

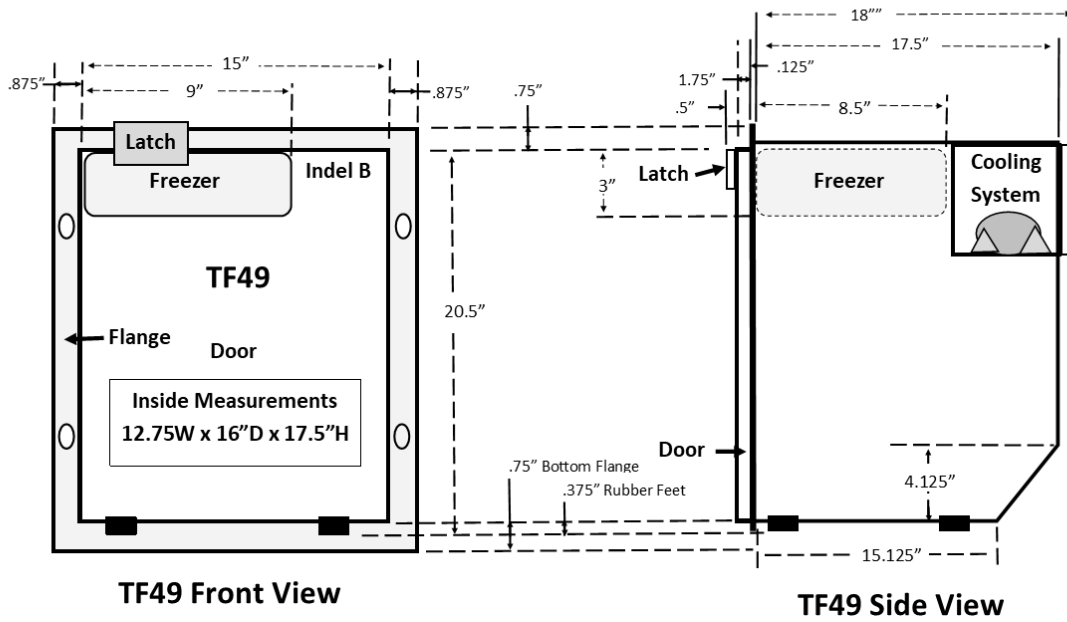

8.9 TFDR49 Dimensional Diagram

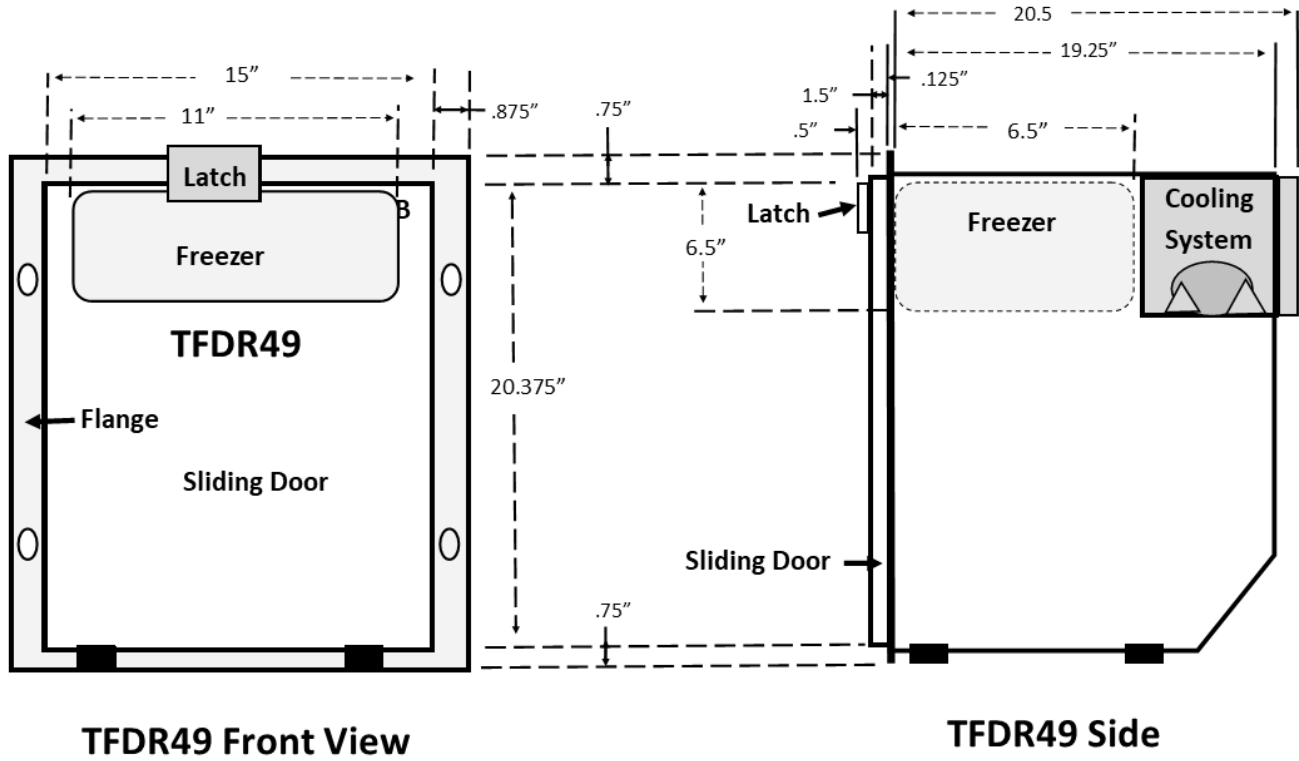

TruckFridge Built-in User Manual

8.10 TF65 Dimensional Diagram

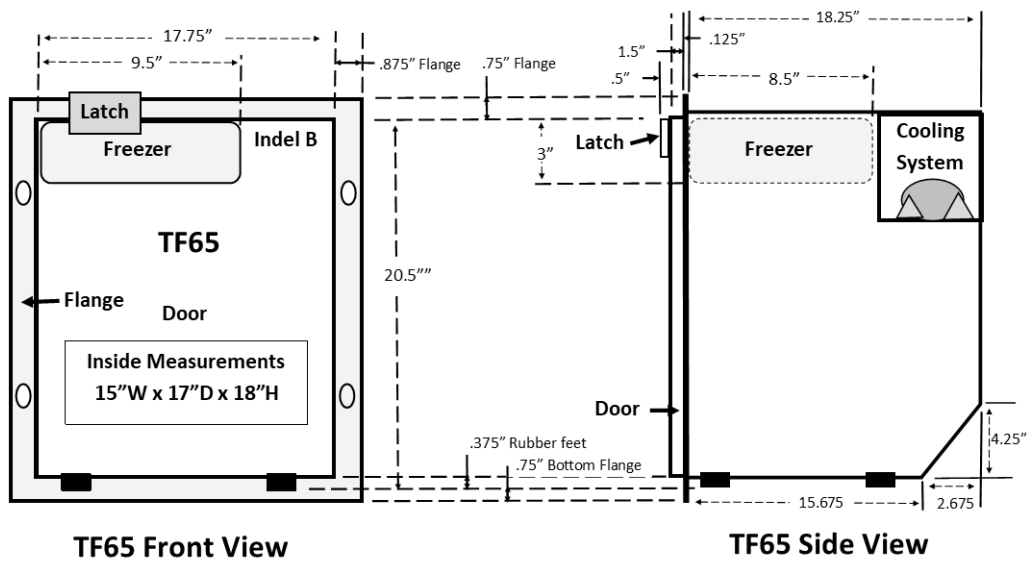

TruckFridge Built-in User Manual

8.11 TF130 Dimensional Diagram

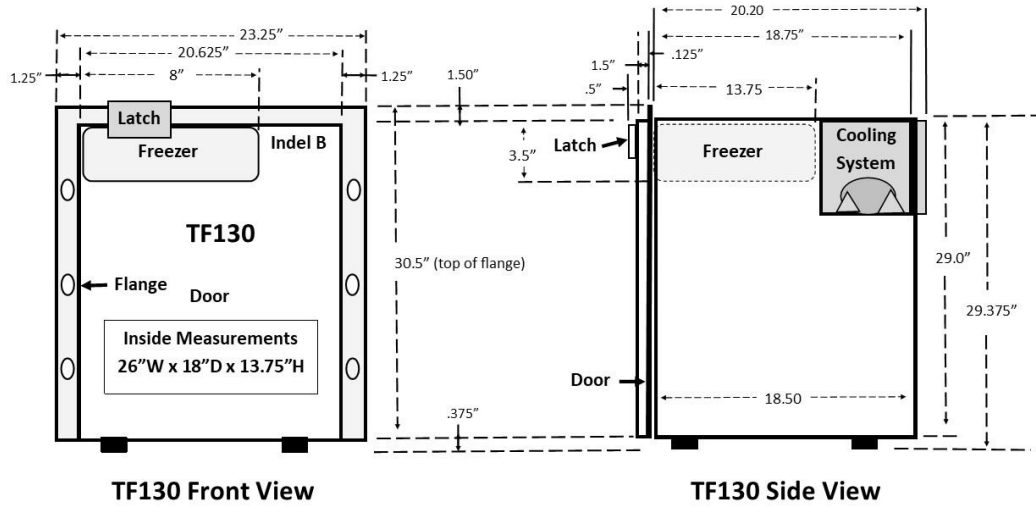

TF130 Front View

TF130 Side View

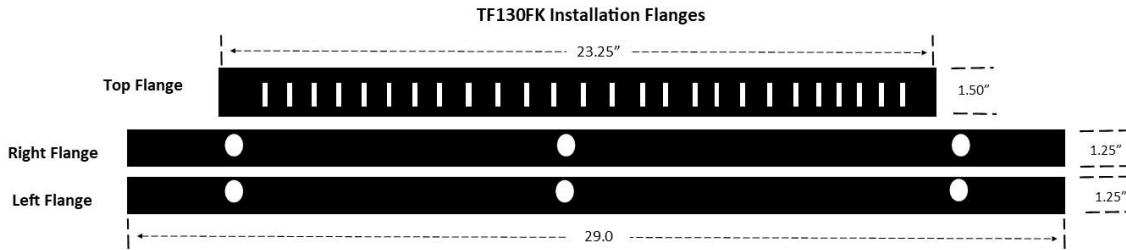

Disclaimer for custom installations As all good cabinet makers know, never make the first cut on cabinets until you have the appliances in front of you. Actual dimensions, screw heads, hinges, and door swings must always be taken into account. Failure to observe this information may result in ill fitting installations or additional costs to you. This is not considered a manufacturing or TruckFridge issue. Specifications may be subject to change without notice or obligation.*

8.12 TruckFridge Installation Ventilation Diagram

TruckFridge Front View

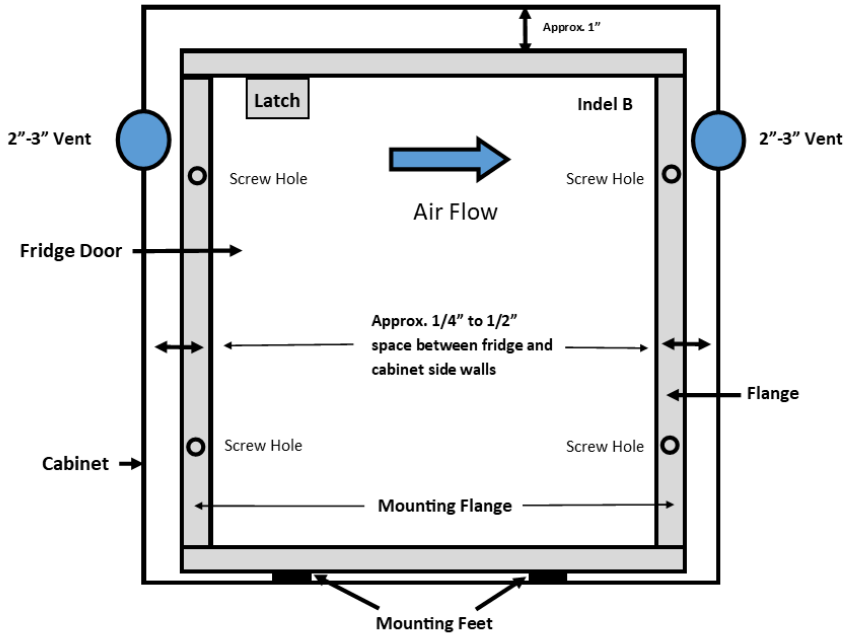

TruckFridge Side View

