

# INSTRUCTIONS

## ASTRAL SOLAR BOLLARD



4553.3030

Please read the instructions before commencing installation and retain for future reference.

### SPECIFICATIONS:

- **Fitting:** Body made in aluminium with clear polycarbonate diffuser.
- **Lamp types:** 2.2W / DC3.7V/ LED 3000K
- **Protection against electric shock:** CLASS III. Does not require earth connection.
- **Ingress Protection:** IP54. Protection against the entry of dust and water splashes.
- **Driver:** not required.
- **Quality/Corrosive rating:** Suitable for outdoor / indoor domestic and commercial use.
- **Ambient temperature range:** 0°C to +60°C.
- **Battery type:** lithium
- **Charge time:** 6-8hrs
- **Working time:** Full light (up to 3hrs), Micro-light (up to 25hrs).

### INSTALLATION INSTRUCTIONS:

**⚠** Electrical products can cause death, injury, damage to property. Installation of this product must be carried out by a qualified electrician, in accordance with SANS 10142. On completion of installation, ensure that the Certificate of Compliance is updated.

- Check the screws and other accessories. (Fig. 1)
- Remove the mounting plate. Drill two holes in the wall and insert the expansion anchors. Install this plate to the wall with the two screws provided. (Fig. 2-3)
- Secure the body to the mounting plate with the screws provided. Press the switch for 3 sec/s after installing. Switch button changes to blue. (Fig. 4)

When the blue light is on the fitting is lit up completely and lasts for 50s (Fig. 1-2) thereafter normal use continues.

### WARNING:

Ensure all items and screws are secure and fitted correctly.

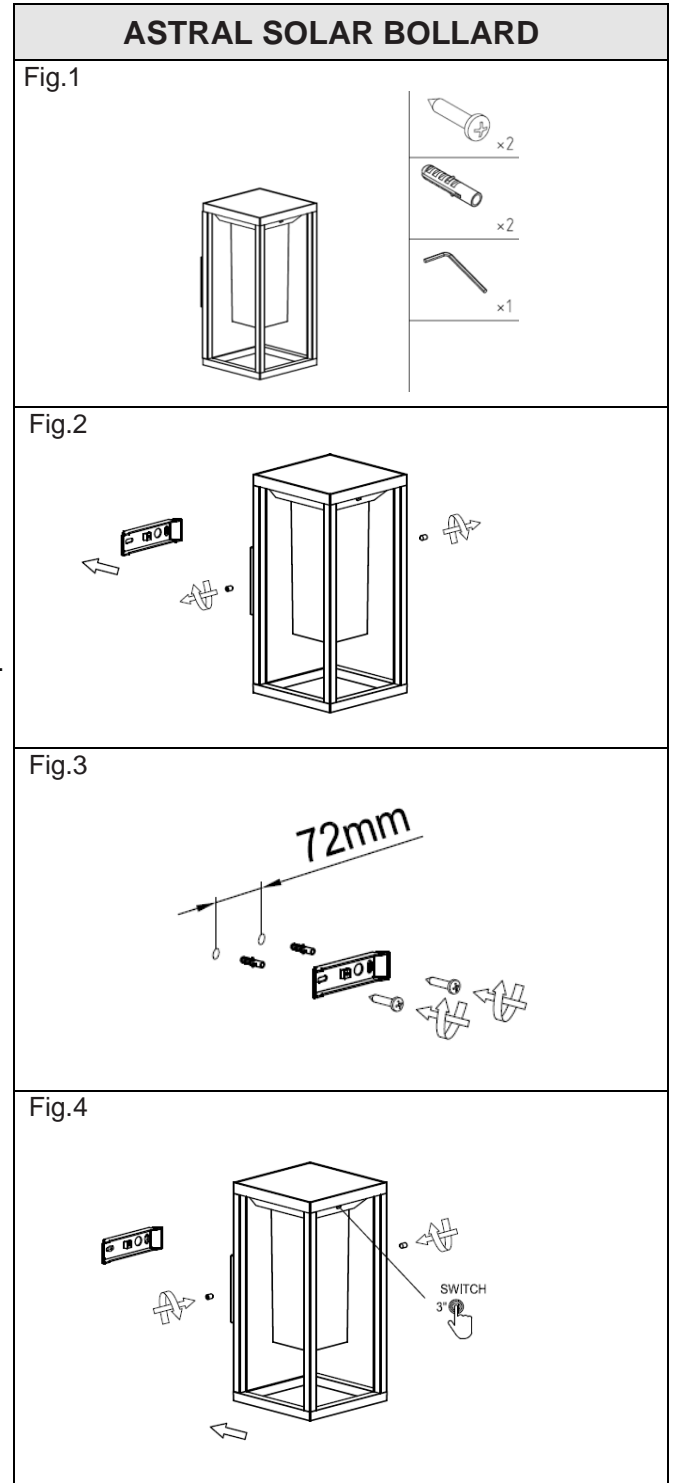

Spazio Lighting (Pty) LTD.

JOHANNESBURG OFFICE: 52 Andries Street | Wynberg/Sandton

CAPE TOWN OFFICE: 36 Milner Street | Paarden Eiland

DURBAN OFFICE: 31 Solstice Road | Umhlanga Ridge

011 555 5555 (Central Switchboard) | [info@spazio.co.za](mailto:info@spazio.co.za)