

〔POWER PACK LIGHT〕 LIGHT BIG BORE KIT 181cc No.1 /2

SPEC CODE	(POWER PACK LIGHT) φ 63 SILVER CYLINDER 230-1300020	(POWER PACK LIGHT) φ 63 BLACK CYLINDER 230-1451020
APPLICATION	MONKEY 125 (JB02)	GROM (JC75)

ATTENTION!

- Injection controller(i-map)(sold separately) and racing exhaust are required for maximum engine performance. Also, please change exhaust to racing, etc.
- Air/fuel setting is required for the parts combination that is not included in pre-installed map.
- Please use unleaded premium gasoline. Because of high compression, regular gasoline might cause of knocking, etc.

- Thank you for purchasing Kitaco product. Read and understand the instruction before installing.
- For installation, Various special tools are required.
- After installation, please use this instruction sheet for setting manual.
- ※ Keep this instruction sheet safe because repair parts do not have instruction sheet.

■ ATTENTION (MUST READ)

- This parts is made exclusive for racing use. Note that racing parts are not covered under warranty. Installed vehicles cannot ride the on general public road.
- We are not responsible for violation of law or damages and accidents caused by assembling mistake and improper setting.
- i-map setting may need if other manufacturer's product is installed.
- Follow the instructions and install correctly. Do not modify the way which is not listed or it will cause damage and trouble.
- Please ask authorized mechanic for assembling and setting. Ask a specialist at specialty shop if you do not understand the role of the surrounding parts.
- Change the engine oil to the new specified engine oil after you break in (about 100km).
KITACO Specified Oil : elf MOTO 4 PRO TECH /PANOLIN STREET 4T RACE)
- Bolts and nuts may get loosen by engine vibration. Make sure not to loosen any bolts and nuts before driving.
- Clean each parts by parts cleaner and use air duster to check whether the oil line is choked up.
- Oil the parts with engine oil when assembling.
- By installing this parts, the output characteristic is different from normal, please enhance the brake to match the power and improve steering stability. Please be careful of riding.
- Do not spark the plug out side of cylinder for spark check. It might cause of fire.
- Refer to the manufacturer service manual when installation.

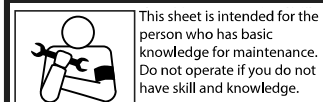

This sheet is intended for the person who has basic knowledge for maintenance. Do not operate if you do not have skill and knowledge.

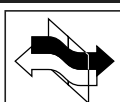

Toxic, highly-volatile gasoline is used during operating. Be sure to ventilate the room. Do not operate for hours in a hermetically closed room.



FLAMMABLES
Inflammable high gasoline is used during operation.



Do not touch the engine parts (cylinder, crankcase, muffler, engine oil, etc...) right after engine operation. Make sure to start the installation after the engine parts are completely cool.



Wear insulated glove when checking the sparking outside the cylinder.

SPECIFICATIONS

- DISPLACEMENT : 181cc [BORE] 63X [STROKE] 57.9 NORMAL SIZE
- COMPRESSION RATIO 11.1:1 (NORMAL 9.3:1)
- FUEL : UNLEADED PREMIUM GASOLINE
- VALVE CLEARANCE STANDARD NUMBER(COLD) IN VALVE : 0.10±0.02mm / EX VALVE : 0.17±0.02mm

REQUIRED TOOLS AND REPAIR PARTS

- VARIOUS GENERAL TOOLS
- THICKNESS GAUGE(COMMERCIALY SOLD)
- UNIVERSAL HOLDER [HONDA GENUINE PRODUCT CODE : 077725-0030000]



PACKING LIST () is 1SET QTY.

FIGURE	NAME	CODE	QTY	GROM	MONKEY	POWER PACK LIGHT 181cc
A	HIGH CAM SHAFT TYPE 2	300-1432010	x1	x1		No decompression feature ※Power pack included.
B	φ 63 CYLINDER	311-1444250	x1	-		
		SILVER 311-1444260	-	x1		
B1	OIL PASS GALLERY	771-9000450	x1	-		T4/28.5mm
		SILVER 771-9000460	-	x1		
B2	ALUMINUM SEALING WASHER 10mm	771-0500999	x4	x4		
B3	SEALING WASHER 6.5mm	70-092-14321	x1	x1		CAM CHAIN TENSIONER M6x18 BOLT
B4	SEALING WASHER 8mm	70-090-14321	x1	x1		CAM CHAIN GUIDE ROLLER BOLT
B5	UNION BOLT RED /M10xP1.25	771-0900900	x2	x2		
C	PISTON KIT LIGHT 181cc	350-1432600	x1	x1		
C1	φ 63 PISTON LIGHT181cc	351-1432600	(x1)	(x1)		
C2	φ 63 PISTON RING (0.8-0.8-1.5)	352-0006630	(x1)	(x1)		
C3	PISTON PIN 13x8x45	353-0001345	(x1)	(x1)		
C4	PISTON PIN CLIP 13mm	354-0000130	(x2)	(x2)		
D1	HEAD GASKET φ 63	961-1432320	(x1)	(x1)		
D2	BASE GASKET	962-1432300	(x1)	(x1)		
E	LARGE CAPACITY INJECTOR x1.6	403-9000020	x1	x1		Power pack included.
-	i-MapCOUPLER ON+FB CANCELLER MONKEY 125 (JB02)	763-1300200	-	x1		Refer to other paper.
		GROM (JC75) 763-1451200	x1	-		

OPTION PARTS

OP1	EX GASKET	H-06	70-963-11006	x1	x1	
OP2	TITANIUM NUT		303-1013711	x1	x1	

OTHER POWER PACK ATTACHED PRODUCTS (Please purchase products that sold separately.)

	NAME	CODE	REMARK
ELECTRICAL SYSTEM	PC INTERFACE CABLE (Sold separately.)	763-0500900	For connecting to PC to make user original map.
COOLER	SUPER OIL COOLER KIT 3/5 LOW (Sold separately.)	-	For GROM / MONKEY 125
RECOMMEND OIL	elf MOTO4 PRO TECH 5w40 1L (Sold separately.)	968-2000021	Recommend engine oil.
	PANOLIN STREET 4T RACE 10W50 1L (Sold separately.)	968-2996001	

ABOUT PRODUCT

- **ATTENTION TO INJECTION CONTROLER (i-map)**
- The pre-installed (set) i-map cannot deal with the processed intake/exhaust port and processed combustion chamber. Air/fuel setting is required for the parts combination that is not included in pre-installed map or combination with other manufacturer's product. In that case, please make original map on user setting map.
- ※ Computer, PC interface cable and facility for air fuel ratio is required to make original map.

ABOUT CYLINDER OIL LINE

The right side of this big bore kit, there is by-pass type oil line. Remove the oil gallery, then install the oil nipple, therefore it is going to be oil line for oil cooler, etc.

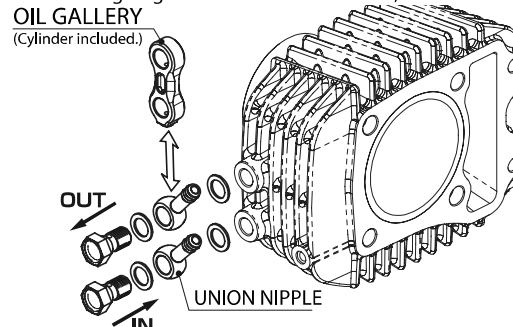

※ Arrow on the illustration is oil cooler line.

TORQUE N · m (1kgf · m :9.80665N · m)

FIGURE	NAME	QTY	N · m
B5	ALUMINIUM BANJO (UNION) BOLT	2	15
N1	CYLINDER HEAD CAP NUT 8mm	4	24
N2	FLANGE BOLT M6x90	2	10
N3	FLANGE NUT 8mm	2	27
N4	L SIDE COVER BOLT M6x20	2	10
N5	CAM SPROCKET BOLT M8x22	1	27
N6	LOCKER ARM SET PLATE BOLT M6 × 10	1	10
N7	CAM CHAIN GUIDE ROLLER PIN BOLT M8	1	10
N8	INTAKE PIPE BOLT M6 × 30	2	10
N9	INJECTOR MOUNTING BOLT	2	10
N10	OIL TEMPERATURE SENSOR M10	1	14.5
N11	FLANGE BOLT M6x14	1	10
N12	TAPPET CAP BOLT M6 × 20	4	10
N13	ADJUST SCREW LOCK NUT	2	9.0

[POWER PACK LIGHT] LIGHT BIG BORE KIT 181cc No.2/2

SPEC CODE	(POWER PACK LIGHT) φ 63 SILVER CYLINDER 230-1300020	(POWER PACK LIGHT) φ 63 BLACK CYLINDER 230-1451020
-----------	--	---

■CYLINDER HEAD & CYLINDER PARTS

Basically, reuse genuine parts if it is unattached.
If there is a hard degradation like a blem, fatigue and wear etc on the reuse parts, please change to new ones.
Please wash each parts before installation.

⚠ Refer to the remark on the table.
OIL — Apply engine oil.

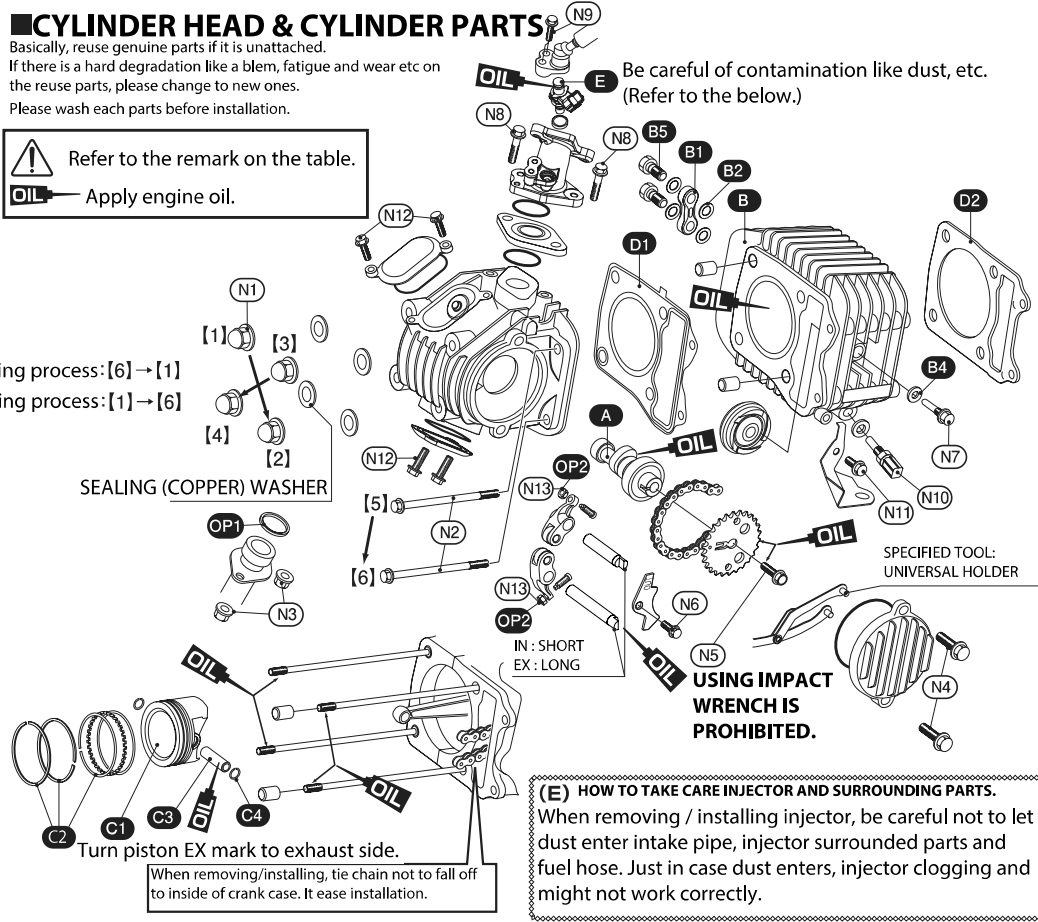

INSTALLING PISTON RING

Refer to the illustration to install.
"POINT"
● Distribute the gap of the ring as shown in the illustration.
● Turn top ring and second ring mark to upward (head).
● There is not up and down to expander and side rail.

Parts data on illustration. (Install in numerical order.)

FIGURE	NAME	QTY
1	EXPANDER	× 1
2/3	SIDE RAIL (same up and down.)	× 2
4	SECOND RING (BLACK)	× 1
5	TOP RING (WHITE)	× 1

※ Install piston turn EX mark to exhaust side.

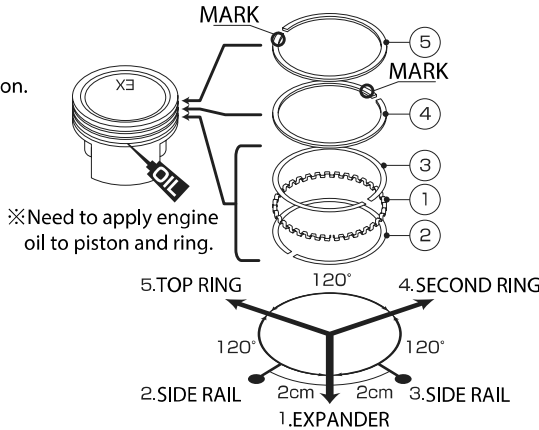

HOW TO REMOVE / INSTALL PISTON PIN CLIP

- 1) Sand pin clip by needle-nose pliers, then haul pin clip joint in piston joint.
- 2) Remove pin clip by sanding joint by needle-nose pliers and pull inside, then pull outside.
- 3) Rotate slowly to remove pin clip.

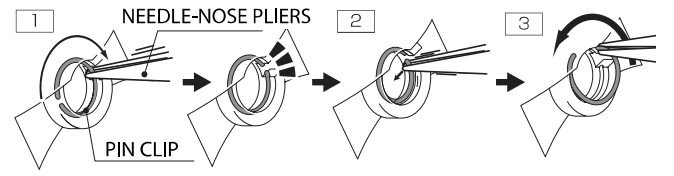

※ Pin clip might pop off, please work carefully.
● Pin clip installation is in reverse order to removing.

HOW TO INSTALL/REMOVE CAM SHAFT SPROCKET

REMOVE
Remove cam sprocket cover, O ring, crank shaft hole cap, timing hole cap and cam chain tensioner flange bolt(M6x18).

INSTALL
1) Make camshaft to compression top dead center position, hang chain to cam sprocket with O mark of the cam sprocket matches cylinder head matching mark, then install temporarily to camshaft.

2) Rotate crank shaft counterclockwise, match the fly wheel matching mark "T" and crank case matching mark, then check cam sprocket "O" mark matches cylinder head matching mark while compression top dead center position. If it does not match, install cam sprocket again.

3) Fix cam sprocket by using universal holder(specified tool), tighten cam sprocket bolt.

4) Inject 4.0cc engine oil from flange bolt(M6x18) hole to push rod, tighten with new sealing washer and bolt.

SETTING VALVE CLEARANCE

- 1) Rotate crankshaft counterclockwise, match fly wheel "T" mark to crank case matching mark. move locker arm to check piston position is compression top dead center position. (It can check by rocker arm sagging. If there is no play, rotate crank shaft again.)
- 2) Insert thickness gauge between adjust screw and valve stem, check out exhaust valve clearance.

● VALVE CLEARANCE STANDARD VALUE (COLD)
IN intake side : 0.10 ± 0.02mm
EX exhaust side : 0.17 ± 0.02mm

ADJUSTING
1) Loosen lock nut, rotate adjust screw to adjust specified valve clearance. After adjusting, tighten lock nut while fixing adjust nut screw. After tighten lock nut, check out valve clearance again. (TORQUE : 9.0N·m)

2) Check each hole cap O ring condition, please change if needed, apply engine oil to O ring, then install valve adjust hole cap, cam sprocket cover, crankshaft hole cap and timing hole cap.

(TORQUE/ crank shaft hole cap:8.0N·m / timing hole cap: 6.0N·m)

ADJUST COMPRESSION TOP DEAD CENTER / VALVE CLEARANCE.

Adjust valve clearance to compression top dead center position(matches each matching mark.)

