



Irene 3 shown in Textured Bronze



Irene

Designed in 2012



Irene 5 shown in Textured Bronze

Cutting a figure like no other, Irene is rustic, yet strikingly modern with either three or five neatly joined propeller-shaped, solid walnut-stained wooden blades. A spherical motor housing complements its minimal profile. Irene is streamline while still appearing warm and natural.

- Available in three sizes: 44"/112cm, 52"/132cm or 60"/152cm diameter with solid wood, walnut-stained machine-cut blades
- Energy efficient, ultra-quiet, six-speed, reversible DC motor with new, reliable technology.
- Constructed of cast aluminium and heavy stamped steel.
- Damp location: All standard finishes. Not recommended for salt water/ocean front applications.
- Limited Lifetime Warranty
- Standard equipment:
 - One 10"/25cm downrod. (18"/ 46cm, 36"/ 91cm & 72"/183cm downrods also available)
 - Vaulted ceiling mount canopy for up to 30 degrees
 - Reverse on six speed, hand-held and wall-mountable remote control.



Note: Overall drop for both fans is 10" / 25 cm plus downrod length



PRESTIGE
FANS

Comes standard with a 10"/25.4cm downrod. 18"/46cm, 36"/91cm & 72"/183cm also available.

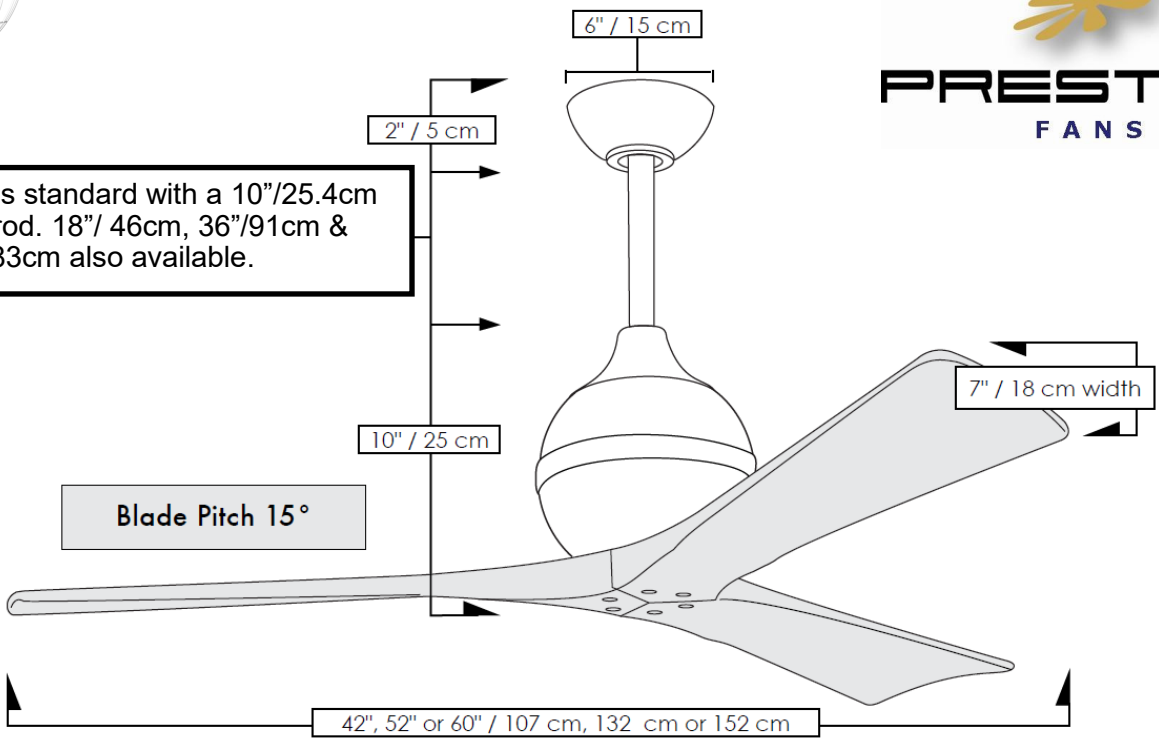

Comes standard with a 10"/25.4cm downrod. 18"/46cm, 36"/91cm & 72"/183cm also available.

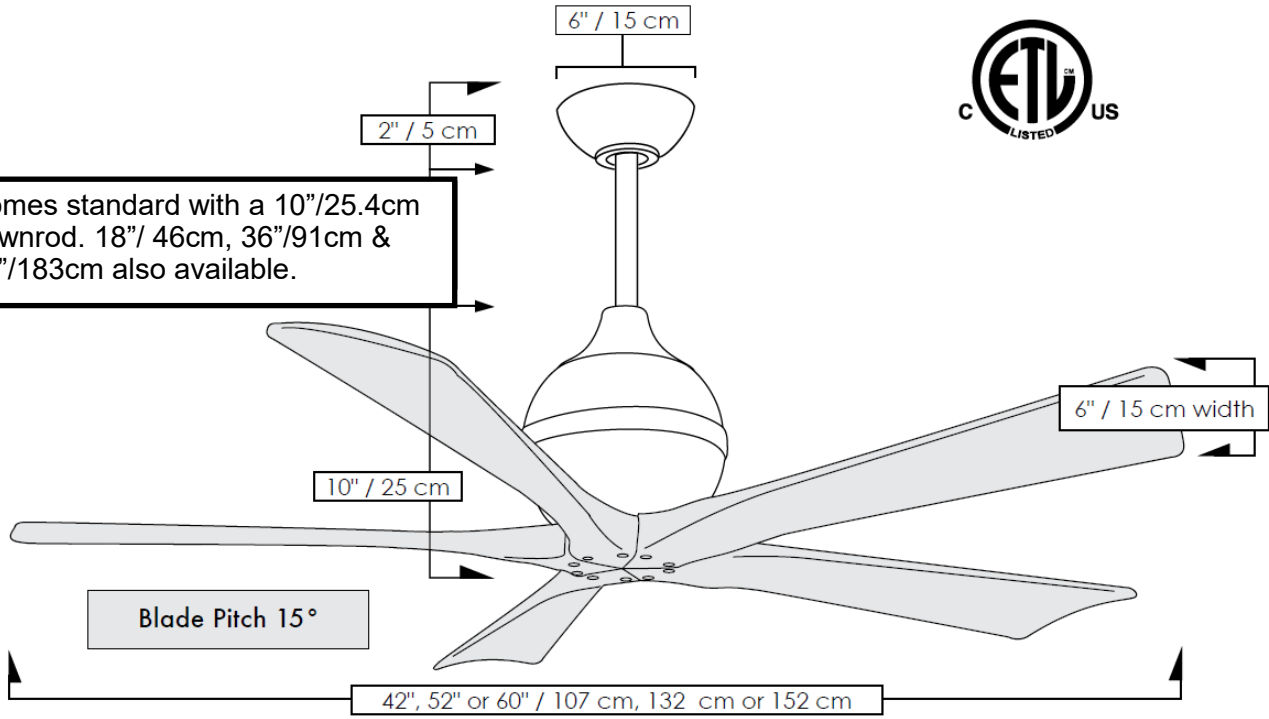

Irene

MOTOR EFFICIENCY DATA						
	42 inch / 107cm		52 inch / 132cm		60 inch / 152cm	
	IRENE 3	IRENE 5	IRENE 3	IRENE 5	IRENE 3	IRENE 5
RPM (Low / High)	52 / 231	51 / 229	51 / 196	51 / 156	52 / 160	52 / 77
CMH (Low / High)	919 / 5975	1447 / 7239	2601 / 10479	3031 / 9825	3547 / 11865	5654 / 8505
Watts (High)	17.08	25.33	32.12	32.18	31.67	31.38