

WOLVERLY 4 RAIL

WOLV-4-E-600-600-xx

12 July 2023

- | | |
|---------------------------|-----------------------------|
| UB - UNLACQUERED BRASS | BB - BRUSHED BRASS |
| CP - POLISHED CHROME | BC - BRUSHED CHROME |
| NP - POLISHED NICKEL | BN - BRUSHED NICKEL |
| LB - LIGHT ANTIQUE BRONZE | LAB - LIGHT ANTIQUE BRONZE |
| MB - MEDIUM BRONZE | MAB - MEDIUM ANTIQUE BRONZE |
| DB - DARK BRONZE | DAB - DARK ANTIQUE BRONZE |
| GP - GOLD PLATED | BG - BRUSHED GOLD |
| GM - GUN METAL | AG - ANTIQUE GOLD |
| MWP - MATT WHITE P.COAT | MBP - MATT BLACK P.COAT |

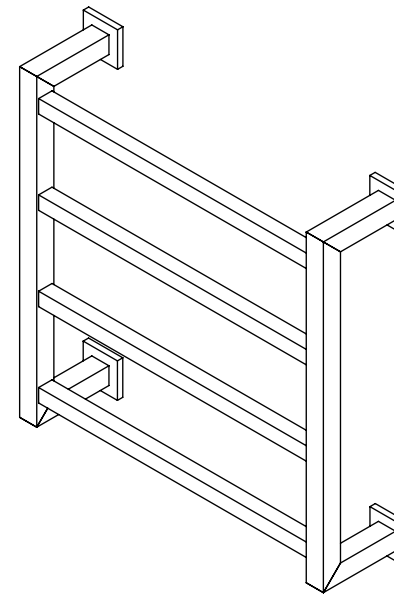

Cable Outlet
(Bottom Right)

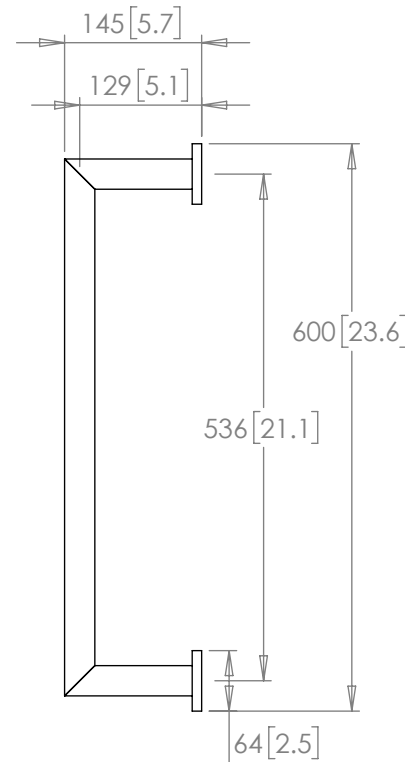
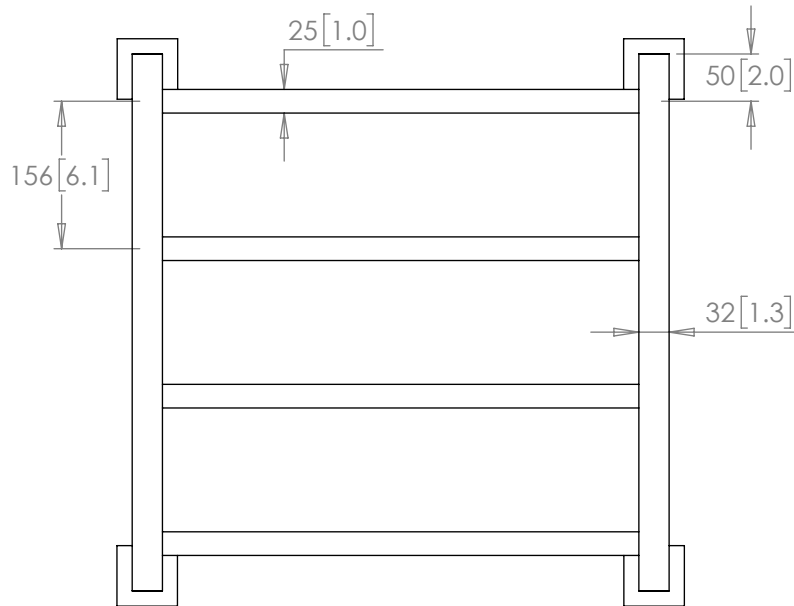
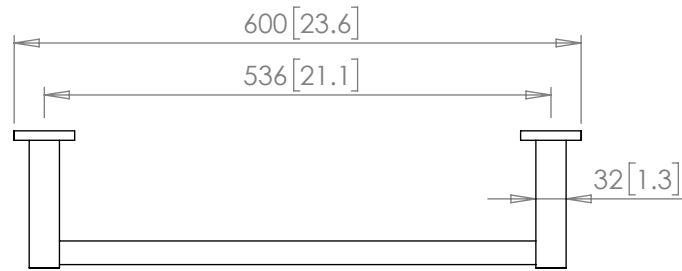

THE STERLINGHAM CO. LTD.

SCALE: 1:8 | APPROX WEIGHT 4.99KG

MANUFACTURED FROM BRASS

Units 2 & 2A Stamford Street
Amblecote, Stourbridge,
Worcestershire
England, DY8 4HR

Telephone : 01384 370901
Fax : 01384 880159
sales@sterlingham.co.uk
USsales@sterlingham.co.uk
www.sterlingham.co.uk



Handmade
in the heart of
BRITAIN