

Q-25907/1

Wollaston 3 Rail	
WOLL-3-E-991-559-145	
REF:	17 April 2024
UB - UNLACQUERED BRASS	CP - POLISHED CHROME
BB - BRUSHED BRASS	NP - POLISHED NICKEL
BN - BRUSHED NICKEL	LB - LIGHT BRONZE
LAB - LIGHT ANTIQUE BRONZE	MB - MEDIUM BRONZE
MAB - MEDIUM ANTIQUE BRONZE	DB - DARK BRONZE
DAB - DARK ANTIQUE BRONZE	GP - GOLD PLATED
AG - ANTIQUE GOLD	GM - GUN METAL
MWP - MATT WHITE P.COAT	MBP - MATT BLACK P.COAT

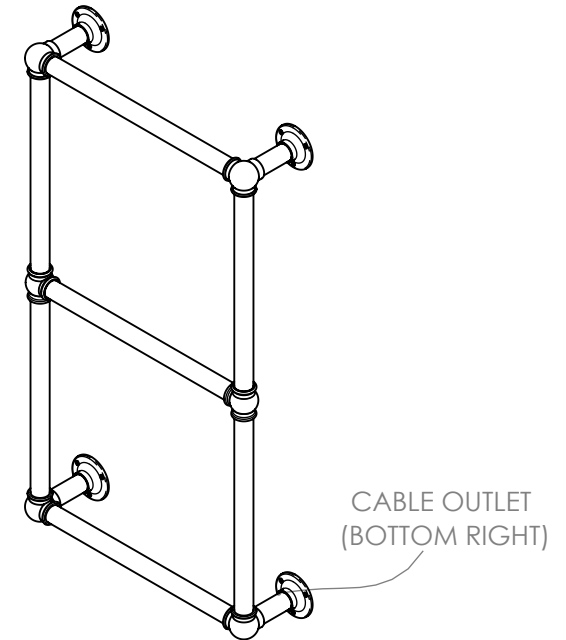
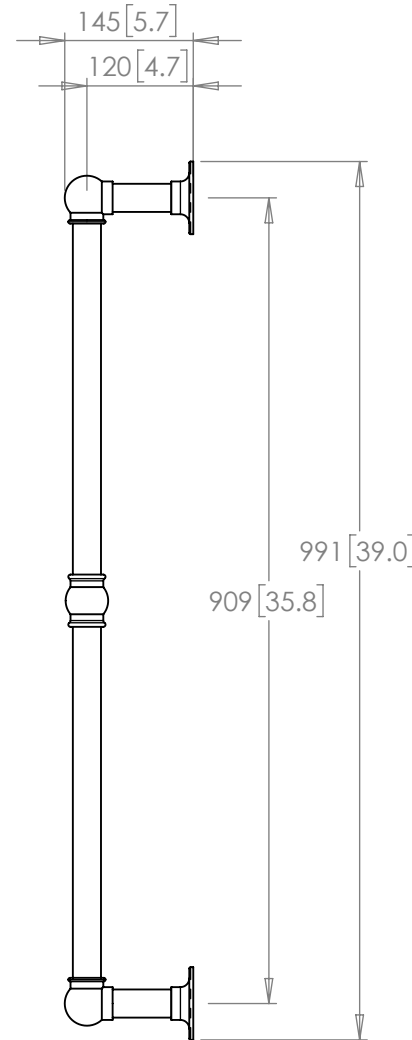
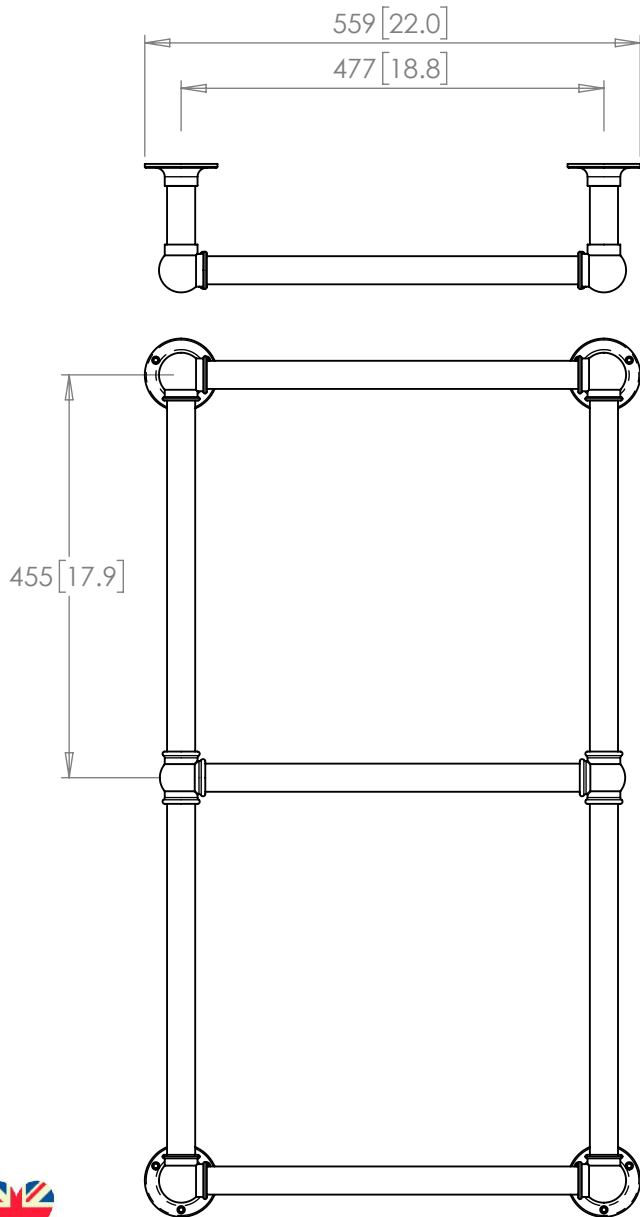

THE STERLINGHAM CO.
LTD.

SCALE: 1:10 | APPROX WEIGHT 5.23KG

MANUFACTURED FROM BRASS

Units 2 & 2A Stamford Street
Amblecote, Stourbridge,
Worcestershire
England, DY8 4HR

Telephone : 01384 370901
Fax : 01384 880159
sales@sterlingham.co.uk
USsales@sterlingham.co.uk
www.sterlingham.co.uk



Handmade
in the heart of
BRITAIN