

# MANUAL & COOKBOOK



*Moist, Tender Meat • No Flame-Ups • Low Cooking Maintenance*



Share the Orion  
Experience  
with friends.

Visit us online:  
[www.theorioncooker.com](http://www.theorioncooker.com)



**Orion Cooker**

[www.TheOrionCooker.com](http://www.TheOrionCooker.com)  
1 (866) 891-3663



**Orion Cooker**

[www.TheOrionCooker.com](http://www.TheOrionCooker.com)  
1 (866) 891-3663



**Orion Cooker**

[www.TheOrionCooker.com](http://www.TheOrionCooker.com)  
1 (866) 891-3663



**Orion Cooker**

[www.TheOrionCooker.com](http://www.TheOrionCooker.com)  
1 (866) 891-3663

## **WARNING**

**FOR OUTDOOR USE ONLY. Carbon Monoxide Hazard.**  
**Never use indoors (home, garage, enclosed porch, tent).**  
**While in use, keep the cooker away from buildings, garages, flammable materials, flammable fluids and automobiles.**

**Do not leave unit unattended at any time while in use.**

## **WARNING**

Failure to follow these instructions could result in death, serious injury and/ or property loss. Read and follow instructions carefully before using the Orion Cooker®! Always read the owners manual before using the Orion Cooker and follow specific usage, assembly and safety procedures. If you have any questions, contact Orion Cooker.

- The Orion Cooker is designed for OUTDOOR HOUSEHOLD USE only.
- Never use the Orion Cooker inside a house, trailer, tent, garage or any enclosed area because carbon monoxide may accumulate and cause death.
- Do not use the Orion Cooker as a space heater.
- Set up the Orion Cooker away from buildings, dry leaves, or any combustible materials. Avoid high traffic areas and always cook in a well-ventilated area. Be mindful of windblown sparks.
- Do not ever use the Orion Cooker unless all parts of the unit are firmly in place and the unit is stable.
- Do not wear loose clothing with hanging shirttails, frills, or apron strings around the cooker when lighting or cooking.
- Never allow children to operate the Orion Cooker or play near it. Keep animals and bystanders out of the cooker area.
- Do not allow anyone to conduct activities around the Orion Cooker when it is in use, or immediately following its use. Never operate the Orion Cooker near combustible surfaces.
- Once the Orion Cooker has been lit, do not touch the charcoals to see if they are hot.

- Allow coals to burn out completely and let the ashes cool for 48 hours before disposing of them.
- Dispose of cold ashes by wrapping them in heavy-duty aluminum foil and putting them in a non-combustible container. Be sure there are no other combustible materials in or near the container.
- If you must dispose of the ashes in less time than it takes for them to completely cool, remove the ashes from both coal rings keeping them in heavy duty foil and soak them completely with water before disposing in a non-combustible container.
- If you have any questions regarding the assembly or operation of the Orion Cooker, please contact us at [sales@orioncooker.com](mailto:sales@orioncooker.com) or **1-866-891-3663**.

## **CAUTION:**

Never move the unit while in use. If moving becomes necessary, do not touch body or the lid as they may be very hot.

## **GENERAL INSTRUCTIONS FOR SAFE USE OF COOKER:**

1. Do not burn trash, leaves, paper, cardboard or plywood in the cooker. The use of seasoned hardwood is recommended. Avoid using softwood such as pine or cedar because they are likely to throw sparks.
2. Keep all screws and nuts tight to be sure cooker is in safe working condition. Inspect on a regular basis to ensure that the cooker is operational.

**NOTE: After repeated use, a discoloration of the metal will occur.**

## **⚠ WARNING ⚠**

## **CARBON MONOXIDE HAZARD**

Burning charcoal produces carbon monoxide, which has no odor and can kill you. **DO NOT** burn charcoal inside homes, vehicles or tents. Use only in well ventilated areas.

## Dear Valued Customer:

Thank you for purchasing the Orion Cooker®. You will find the Orion Cooker will indeed make you a backyard BBQ King! Now, it is possible to have the moist, tender product you long for at a fraction of the time and effort. The Orion Cooker provides enough diversity to conquer any cooking situation. Hang six racks of baby back ribs on the rib hangers, cook a moist turkey on the poultry stand or cook a salmon filet on one of the three cooking grates. You and your guests will be in for a culinary treat!

We invite you to try any and all foods on the Orion Cooker and submit them to us on the recipe section of our web site at [www.theorioncooker.com](http://www.theorioncooker.com).

Again, many thanks for purchasing the Orion Cooker. If you have any questions, feel free to contact us at [sales@theorioncooker.com](mailto:sales@theorioncooker.com) or 1-866-891-3663.

*Best Regards,*

Orion Cooker



<b>Table of Contents</b>	<b>Page #</b>
Orion Cooker® Assembly . . . . .	6
Accessory Assembly Options . . . . .	9
Items Needed to Cook on the Orion Cooker . . . . .	10
General Cooking Instructions . . . . .	10
General Cooking Instructions Displayed . . . . .	11
General Cooking Guide . . . . .	13
Recipes . . . . .	14–23
Boston Butt	
Beef Brisket . . . . .	14
Wickers Whole Chicken . . . . .	15
Hush Yo’ Mouth Baby Back Ribs	
Grandpa Fitz’s Turkey . . . . .	16
Turkey	
Salmon Filet . . . . .	17
Standing Rib Roast	
“Mello” Boston Butt . . . . .	18
Tequila Chicken Wings	
Alder Chicken Halves . . . . .	19
White Wine Pork Chops	
Brats	
Boneless Leg of Lamb . . . . .	20
“DUSTY’S“ Smokehouse Pork Chops	
Porkaliscious Roulade . . . . .	21
Caribbean Jerk Shrimp	
Bru’s 2-Meat (Turkey ‘n Pork) . . . . .	22
Bru’s 3-Meat (Turkey ‘n Pork ‘n Rib Roast) . . . . .	23
Wood Chip Recommendations . . . . .	24
Meat Doneness Table . . . . .	24
Frequently Asked Questions . . . . .	25–26

# Orion Cooker® Assembly:

Please read all instructions and warnings before assembly.

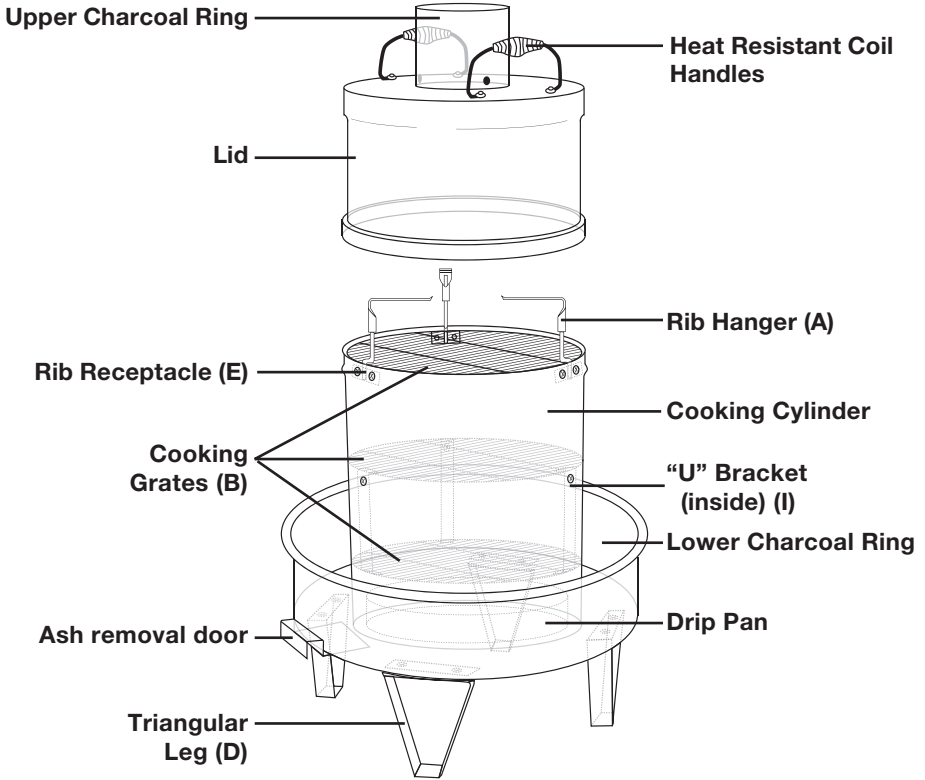

## Parts Included:

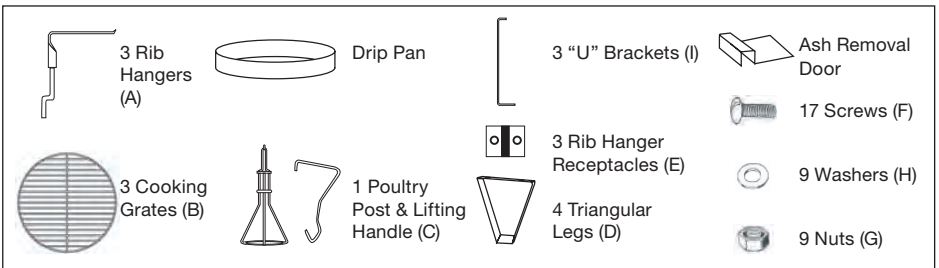

**Tools needed:** Phillips head screwdriver, Crescent wrench or socket wrench set.

## Step 1:

### Attach Legs

1. Align the two holes of the legs (D) with the two holes on the metal strips located underneath the lower charcoal ring.
2. Place screw (F) in aligned holes and tighten using a Phillips head screwdriver.
3. Repeat steps 1 and 2 for remaining legs.

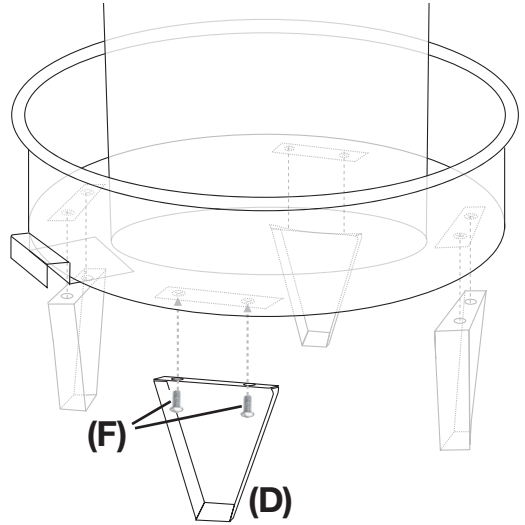

## Step 2:

### Attach "U" Brackets

1. Align the hole at the top of the "U" bracket (I) with the hole in the center of the cooking cylinder and slide one screw (F) through the aligned holes.
2. Place washer (H) and nut (G) over screw on the inside of the cooking cylinder. Tighten nut (G) using Crescent wrench and Phillips head screwdriver.
3. Repeat steps 1 and 2 for the remaining "U" brackets.

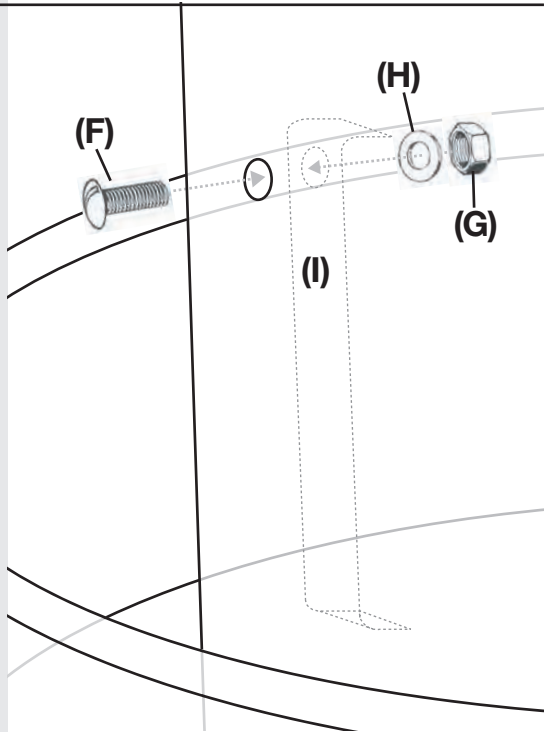



## Step 3:

### Attach Rib Receptacles

1. Align the two holes of the Rib Receptacle (A) with the top two holes in the cooking cylinder and slide two screws (F) through the aligned holes.
2. Place washer (H) and nut (G) over screw on the inside of the cooking cylinder. Tighten nut (G) using Crescent wrench and Phillips head screwdriver.
3. Repeat steps 1 and 2 for remaining Rib Receptacles.

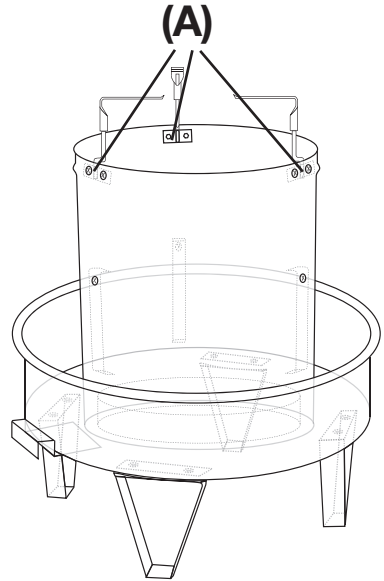

### Top View

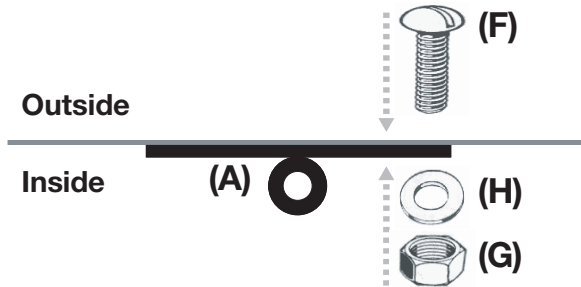

### Side View

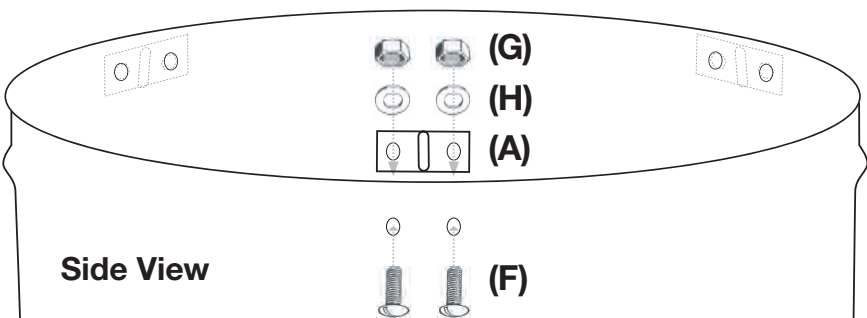

## Accessory Assembly Options

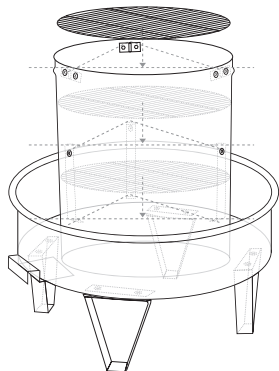

### 3 Cooking Grates:

Roasts, small chickens, pork tenderloins, pork chops, chicken wings, chicken halves/parts, fish filet and seafood—Grates are removable and can be used individually to accommodate larger cuts of meat or can be used together to accommodate large quantities.

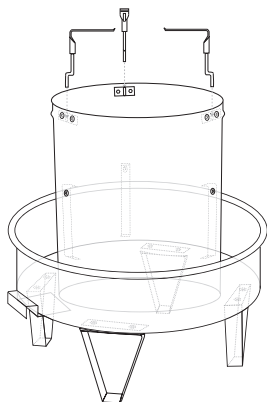

### 3 Rib Hangers:

Ribs—Remove all cooking grates. With a knife, pierce ribs between the 2nd and 3rd bone on the wide end of the rack. Hang ribs vertically by sliding rib hanger through the opening.

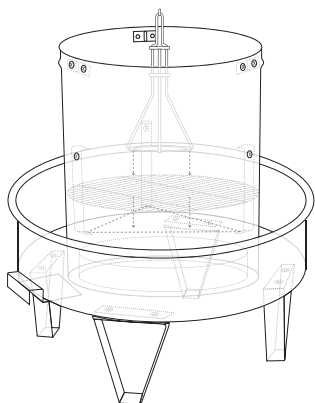

### Poultry Stand and Lifting Handle:

Whole turkeys and large roaster chickens—Ensure neck and giblets are removed from poultry product. Insert poultry stand into large cavity of the poultry product, ensuring the top of the poultry stand is exposed through the neck. Remove the top two cooking grates. Use lifting handle to place stand on the bottom cooking grate. Ensure stand is well balanced on cooking grate. When cooking is complete, use lifting handle to remove poultry stand.

## Items Needed to Cook on the Orion Cooker®

- 12.5 lb bag of instant light charcoal briquettes. Note: For smaller cuts of meat or smaller quantities of food, less charcoal can be used. When less charcoal is used, make sure that the briquettes in the lower charcoal ring are touching the cooking cylinder. When using less charcoal, cooking times will be extended.
- **Optional:** Wood chips. Wood chips add extra color and flavor to the meat product. When using wood chips, there is no need to soak them prior to cooking. A list of options for wood chips can be found after the recipe section in this Manual .
- **Note:** The majority of cooking applications do not require liquid in the drip pan. The only exceptions are beef briskets, fish and seafood.

## General Cooking Instructions

1. For easy clean up, line the drip pan with heavy duty tin foil.
2. Place the the drip pan in the cooking cylinder.
3. (Optional) Place wood chips between the side of the drip pan and the inside wall of the cooking cylinder. The heat from the outer charcoal ring will cause the chips to smolder when placed against the wall of the cooking cylinder. Note: Do not place wood chips underneath the drip pan.
4. Prepare food and choose appropriate accessory.
5. Affix food to appropriate cooking accessory and place in the cooking cylinder or place food on cooking grates in the cooking cylinder.
6. Secure the lid on the cooking cylinder.
7. Place a 12.5 lb bag of instant light charcoal around the lower charcoal ring, with the exception of 10-12 briquettes. Note: For smaller cuts of meat or smaller quantities of food, less charcoal can be used. When less charcoal is used, make sure that the briquettes in the lower charcoal ring are touching the cooking cylinder. When using less charcoal, cooking times will be extended.
8. Place the remaining 10-12 briquettes in the upper charcoal ring on the lid.
9. Light charcoal in both the upper and lower charcoal rings and return at the designated time!

Trust our general cook times. Do not check before designated time.

If the lid is removed the convection current will be lost and cook times will increase. Remember—LOAD, LIGHT, EAT!!

Always use a meat thermometer to check doneness.

## General Cooking Instructions Displayed

### STEP 1: LOAD

1. Load the Orion Cooker® with ribs, turkey, chicken, seafood, etc.
2. Place charcoal in both the top and bottom rings.
3. Wood chips can also be added to the cooking chamber if a smoke flavor is desired.

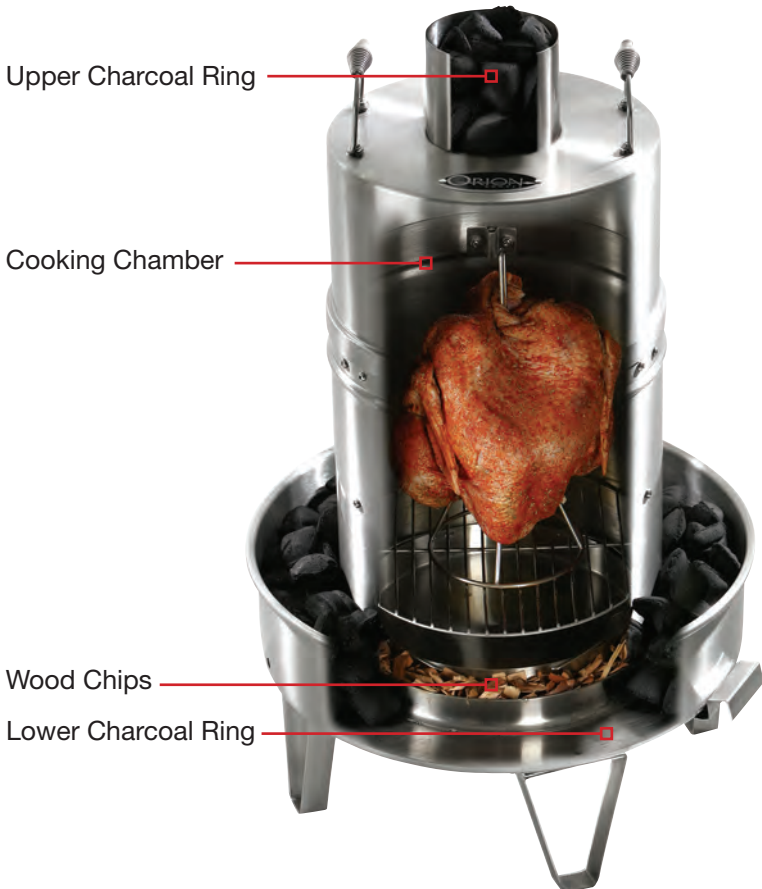

## STEP 2: LIGHT

1. Light the charcoal in both of the charcoal rings.
2. Since charcoal is the only heat source, you don't have to worry about any unhealthy fatty oils or hot, messy spills.
3. 100% indirect heat prevents carcinogens associated with direct charcoal heat.



## STEP 3: EAT

1. After lighting the charcoal, let the Orion Cooker do the rest of the work.
2. Indirect heat from the charcoal will create a constant convection current that circulates within the cooking cylinder, cooking your meat quickly and evenly.
3. It's hands-off and maintenance-free, with no flipping, basting or other troublesome tasks required.



# General Cooking Guide

Product	Weight	Cook Time*
Chicken	3-4 lb	7 min per pound
Whole Turkey	20 lb	2 hours 15 min (7 min per pound)
Whole Turkey	15 lb	1 hour 45 min (7 min per pound)
Prime Rib	7-8 lb	1 hour 30 min  (10-12 min per pound. 10 min per pound for boneless. 12 min per pound for bone-in, for medium rare or 145 degrees)
Beef Brisket	6-7 lb	30 min per pound. When cooking multiple flats, take the largest flat and multiply by 30 min per pound.
Beef Brisket	13-14 lb	5 hours
Baby Back Ribs	6 racks	1 hour 15 min
Baby Back Ribs	3 racks	45 min to 1 hour
Pork Roast (boneless and not a Boston Butt)	7 lb	45 min
Boston Butt	6-8 lb	3 hours 30 min
Boston Butts (2)	6-8 lb/each	5 hours
Pork Chops	1.5" cut	35-40 min
Salmon Filet	2-3 lb	30 min
Chicken Wings	20 wings	7 min per pound
Chicken Wings		7 min per pound
Turkey Breast		12 min per pound
Ham (Butt portion)	8.5 lb	2 hours (160 degrees—slicing temperature)

*\*Cook times are approximate*

# Recipes

Looking for mouth-watering ideas of what to make on your Orion Cooker®? Try out one of the recommended treats listed below! Or, if you have a recipe you would like to recommend to other Orion Cooker owners, submit them online to [sales@theorioncooker.com](mailto:sales@theorioncooker.com).

---

## **Boston Butt**

*6-8 lb Boston Butt*

*Salt*

*Orion's Pork and Poultry Rub*

Rub meat with Orion's Pork and Poultry Rub. Place the meat on the bottom cooking grate inside of the cooker. Then, fire up your Orion Cooker and cook for 3 hours and 30 minutes, or 195 degrees (pulling temperature). Check the meat temperature with a thermometer to make sure it is done. Best if cooked with hickory chips.

Tom Bourne

*Atlanta, GA*

---

## **Beef Brisket**

*12-13 lb Brisket*

*Seasoning*

*Apple Cider Vinegar*

Soak the brisket in apple cider vinegar for 6-10 hours prior to cooking.

Remove brisket from vinegar and pat dry with a paper towel. Then, cut the brisket in half and trim if needed. Apply dry rub to the meat. Fill drip pan full with an even mixture of apple cider vinegar and water. Place wood chips between the drip pan and the inside wall of the cooking cylinder. Place the larger cut brisket on the bottom cooking grate and the remaining piece on the middle cooking grate. Place 13 lb charcoal in the upper and lower charcoal rings. Light the coals and come back in 4 hours and 30 minutes.

Walter H McClanahan

*Humboldt, TN*

---

## **Beef Brisket**

*4-5 lb Brisket*

*Dr. Pepper (not diet)*

*Apple Cider Vinegar*

*4 Tbsp Brown Sugar*

*Garlic Powder*

*Worcestershire Sauce*

*Soy Sauce*

*4 Strips of Bacon*

Poke holes in the brisket with a meat tenderizer. Then, place brisket in a zip-lock bag, add a 3-1 ratio of Dr. Pepper to Apple Cider Vinegar (enough to cover the brisket), 4 Tbsp of Brown Sugar, a little Garlic Powder, Worcestershire Sauce, and Soy Sauce. Seal the zip-lock bag, check it for leaks, and place bag in the fridge for 4-5 days. Flip it on occasion. Take the brisket out of the marinade 45 minutes before cooking. Add hickory wood chips between the drip pan and the inside wall of the cooking cylinder and put about 28 oz. of water in the drip pan. Place the brisket on the middle rack, fat side up, and put the bacon strips on top of the brisket. Cook at 25-30 minutes per pound, to an internal temperature of 195-200 degrees.

When you take the brisket out of the Orion, double wrap it in aluminum foil. Let it rest for 90 minutes. Cut thinly against the grain and enjoy.

Tom Damoulakis

---

## **Wickers Whole Chicken**

*3-4 lb Whole Chicken*

*Wickers Marinade*

*Honey (to taste)*

*Salt & Pepper (to taste)*

Marinate chicken in Wickers for 2 hours. Remove chicken from marinade and inject it with more Wickers. Rub outside of chicken with a mixture of honey, salt and pepper. Place the chicken on the poultry stand and place inside the cooker. Then, fire up your Orion Cooker. Cook for 1 hour and 30 minutes, or until done. Use a meat thermometer placed in the middle of the breast to ensure the chicken is thoroughly cooked. Great if cooked with apple chips, which add a splendid flavor and crispiness to the skin!

Fargason Erb

*Memphis, TN*



## Hush Yo' Mouth Baby Back Ribs

<i>Baby Back Ribs (1-6 racks)</i>	<i>1 tsp Cayenne Pepper</i>
<i>1 c Apple Cider Vinegar</i>	<i>2 cloves Garlic</i>
<i>Orion's Dry Rub</i>	<i>Salt (to taste)</i>
<i>1 c Ketchup</i>	<i>Tabasco (to taste)</i>
<i>5 Tbsp Mustard</i>	

Remove the ribs from the package, rinse and pat dry. Apply Orion's Dry Rub evenly to the ribs. Affix the ribs to the rib hangers and place in the cooker. Then, fire up your Orion Cooker and cook for 1 hour and 15 minutes\*, or until done. Best if cooked with cherry chips.

Barbecue Sauce (optional): Mix vinegar, ketchup, and mustard until it's a light orange color. Add the cayenne pepper, garlic, salt and Tabasco sauce to taste. Apply before and after cooking.

\*This time is for six racks of ribs. For fewer ribs, the time will be less. 3 racks should cook for 1 hour and 10 minutes.

Lizzie Powell  
Atlanta, GA

---

## Grandpa Fitz's Turkey

<i>12-20 lb Fresh Turkey</i>	<i>1 tsp Garlic Salt</i>
<i>1 tsp Paprika</i>	<i>1/4 c Balsamic Vinegar</i>
<i>1/4 Stick of Butter</i>	<i>Salt &amp; Pepper (to taste)</i>
<i>1/4 c Olive Oil</i>	<i>1 tsp Tabasco</i>
<i>1 tsp Celery Salt</i>	<i>1 tsp Mustard Powder</i>
<i>1/4 c Lemon Juice</i>	

Slice butter into 4-5 pieces. Use a knife to make slits in the skin of the turkey breast and legs. Slide the butter slices under the skin and rub the outer skin with butter. Mix celery salt, garlic salt, mustard powder, table salt and pepper in a small bowl. Rub mixture on outside of turkey to season it. Rub the inside of the turkey cavity with the paprika. Stir the olive oil, lemon juice, balsamic vinegar, Tabasco sauce, salt and pepper together in another small mixing bowl and inject the resulting basting sauce into the breast and thighs of the turkey. Wedge cherry or apple chips between the drip pan and the inside wall of the cooking cylinder. Place the turkey on the poultry stand and place stand on the bottom grate using the lifting handle. Fire up the cooker and cook for 7 minutes per pound, or until it's done. Use a thermometer to check the temperature of the turkey by placing it in the breast.

Great if cooked with apple or cherry chips, which add a splendid flavor and crispiness to the skin!

Michael Fitzgerald  
*West Palm Beach, FL*

---

## **Turkey**

*12 -20 lb Fresh Turkey*                      *Olive oil*  
*Orion's Pork and Poultry Rub*

Wash turkey and pat dry. Rub skin with olive oil. Apply Orion's Pork and Poultry Rub to skin of turkey. Place cherry or apple chips between the drip pan and the inside wall of the cooking cylinder. Place the turkey on the poultry stand and place stand on the bottom grate using the lifting handle. Fire up the cooker and cook for 7 minutes per pound, or until it's done. Use a thermometer to check the temperature of the turkey by placing it in the breast.

Anthony Bogiatis  
*Atlanta, GA*

---

## **Salmon Filet**

*2-3 lb Salmon Filets*                      *1/4 cup Pepper*  
*1/4 cup Rosemary*                      *3 Lemons*  
*1/4 cup Salt*                      *Apple Wood Chips (3)*

Mix salt, pepper and rosemary together in small bowl. Cut 9 lemon slices 1/8 inch thick. Evenly spread the salt, pepper mix on the salmon filets. Place lemon slices on top of filets. Add apple chips between cooking cylinder and drip pan. Fill drip pan full with water. Place cooking grate on top level and place filet on cooking grate. Add charcoal to upper and lower charcoal rings. Light both upper and lower charcoal rings and check after 30 minutes. Filet will be cooked when meat is flaky.

*\*For more of a smokier flavor, place chips between drip pan and cooking cylinder. Without lid on cylinder, light coals in lower charcoal ring. Check cooking cylinder after about 15 minutes. When the chips begin to smoke, place filets on cooking grate. Place lid on cooking cylinder and light the unlit coals in the upper charcoal ring. The filets will be done when the meat is flaky—roughly 30 minutes.*

John Underwood  
*Highlands, NC*

---

## **Standing Rib Roast**

*7-8 lb Standing Rib Roast*  
*Lawry's Seasoning™*

*Garlic Powder*  
*Fresh Black Pepper*

Apply Lawry's™ evenly on all sides of the roast. Lightly sprinkle garlic powder on all sides. Use a pepper mill to distribute coarse fresh cracked pepper on all sides. Place drip pan in the bottom of the cooking cylinder. Place cooking grate on the middle level inside the cylinder. Place meat on the middle cooking grate. Place the lid on the cylinder. Add charcoal to the upper and lower charcoal rings and light the coals. Check after 1.5 hours for doneness. (Cooking time should be 12-15 minutes per pound depending on how rare you prefer your meat.)

Cam Long  
Macon, GA

---

## **“Mello” Boston Butt**

*5-8 lbs Boston Butt*  
*3 liters Mello Yellow™*  
*Orion's Dry Rub*

Pour 3 liters of Mellow Yellow in large pot. Place Boston Butt in the pot.

Using a fork, pierce all sides of the meat. Marinate for 24 hours in refrigerator.

After 24 hours, remove meat from pot and apply Orion's Dry Rub evenly over the meat. Add hickory or mesquite chips between cooking cylinder and drip pan. Place meat fat side up on the top level cooking grate. Add charcoal to both the upper and lower charcoal rings. Light and come back in approximately 3.5 hours. Check for doneness with thermometer. Depending on how much fat is in the meat, cook times may vary.

Adam Brasher  
Gainesville, GA

## **Tequila Chicken Wings**

*20-40 Chicken Wings*

*1 pint Tequila*

*2 c Lime Juice*

*2 c Lemon Juice*

*2 Tbsp Salt*

*1 Tbsp Tabasco sauce*

*Orion's Pork and Poultry Rub*

Take wings out of package and wash with water. Dry with paper towel. Place selected amount of wings in large zip lock bag. Add tequila, lime juice, lemon juice, salt and Tabasco sauce to the chicken in the bag. Marinate for 6 hours. Remove the wings from the bag, pat dry and apply Orion's Pork and Poultry Rub. Add apple chips between the cooking cylinder and drip pan. Place appropriate number of grates inside of cooking cylinder and place the chicken wings on the grates. Place charcoal in the upper and lower charcoal rings. Light and come back at designated time. Check meat for doneness. Cooking times should be approximately the total weight of the chicken multiplied by 7 minutes a pound.

Rob Howells

*Dublin, CA*

---

## **Alder Chicken Halves**

*3-4 lb Whole Chicken*

*Orion's Dry Rub*

*Salt*

Take whole chicken out of package. Rinse thoroughly. With cutlery shears, cut whole chicken in half so there will be a breast on each half. Place the two halves in a large pot. Fill with cold water and pour in a cup of salt. Add ice cubes to water (1 layer of ice cubes on top of water). Place in refrigerator for two hours prior to cooking. Remove chicken halves from water and pat dry with paper towel. Sprinkle Orion's Dry Rub evenly over each half. Place Alder chips between cooking cylinder and drip pan. Place cooking grate in cooking cylinder. Place chicken halves cut side down on cooking grate. Place instant light charcoal around upper and lower charcoal rings. Place the lid on the cooking cylinder. Light and come back in 1 hour and 10 minutes. Check meat for doneness.

David Dawkins

*Fayetteville, NC*

## White Wine Pork Chops

*Four 1.5" Cut Boneless Pork Chops*                      *2 tsp Salt*  
*2 tsp Garlic Powder*    *2 tsp Onion Powder*  
*4 c White Wine*

Place the 4 pork chops in a large zip lock bag. Pour white wine, salt, garlic powder and onion powder in bag with pork chops. Marinate in refrigerator for 3 hours prior to cooking. Remove pork chops from bag and place on plate. Drizzle marinade on either side of pork chop. Save half of marinade for drip pan. Place apple chips between drip pan and cooking cylinder. Pour half of the marinade in the drip pan (the drip pan will already be in the cooking cylinder). Place cooking grate inside of cooking cylinder. Place 4 pork chops on cooking grate. Add charcoal to both the top and bottom charcoal ring. Light and come back in 35-40 minutes. Check meat for doneness.

\*\*For more of a smoke flavor, place chips between the drip pan and cooking cylinder. Without lid on cylinder, light coals in lower charcoal ring. Check cooking cylinder after about 15 minutes. When the chips begin to smoke, place chops on cooking grate. Place lid on cooking cylinder and light the unlit coals in the upper charcoal ring. The chops will be done in 35-40 minutes. Check meat for doneness.

Chip Adair  
Atlanta, GA

---

## Brats

*15-20 Brats*  
*Cherry or Apple Wood Chips*

Place wood chips between drip pan and cooking cylinder. Load all 3 grates with brats. Place lid on cooker. Light both charcoal rings and come back in 1 hour and 15 minutes.

---

## Boneless Leg Of Lamb

*6-7 lb Leg of Lamb (deboned, rolled and tied)*                      *Rosemary*  
*Garlic*    *Salt*  
*Lemon Juice*

Cut 10-12 slits into outside of lamb and insert slivers of garlic under the slits. Rub the entire leg with lemon juice and season with rosemary and salt.

If using wood chips, use a mild wood such as apple. Place about 16 oz. of

liquid in the drip pan and cook to about 135 degrees internal temperature. This will be roughly 12 minutes per pound. Then, let the lamb rest about 25 minutes.

Tom Damoulakis

---

## **“DUSTY’S” Smokehouse – Pork Chops**

*Six 2-2-1/4” Thick Loin or Center Cut Bone-in Pork Chops*

*Preferred Wood Chips (such as apple)*

*Preferred Pork Dry Rub*

Dissolve 1/3 cup of pork rub in 1 gallon of water and brine chops for 2 hours. Remove chops and pat dry with paper towels. Rub chops all over with preferred pork rub, cover with plastic wrap, and bring to room temperature. In the meantime, fire up your Orion Cooker with your preferred wood chips, and wait until the chips are really smoking before adding the chops to the cooker. Place the chops bone side down on the racks and smoke to 135 to 140 degrees (check after 35 minutes). Remove, cover, let the chops rest for 20-25 minutes and ENJOY.

Wise Dusty

Bowie , MD

---

## **Porkaliscious Roulade**

*1 Pork Tenderloin*

*2 Slices Ham*

*4 Slices Swiss Cheese (scored)*

*9 Slices Bacon*

*Maple Dijon cream sauce (optional)*

Pound tenderloin flat. Lift and position bacon slices side by side under it. Layer 2 slices of Swiss cheese on the tenderloin, followed by 2 slices of ham, and then the remaining 2 slices Swiss cheese. Roll up tenderloin from long side (scoring the cheese lengthwise makes this easier, or use shredded cheese instead). Starting from the middle, wrap the bacon around the tenderloin and affix with skewers. Once wrapped, it will look somewhat like a spine. Then, cut the tenderloin in half to fit in the Orion Cooker. You may want to add a good homebrew beer in the drip pan and apple wood chips around the edge. Start cooking for about 45 minutes. You can cook up to 4 tenderloins like this at once. To serve, cut between each slice of bacon to have a nice thick roulade. Serve with a maple Dijon cream sauce (optional).

Cheri H

## **Caribbean Jerk Shrimp**

*25-50 Tail-on, Peeled/Deveined Shrimp (Colossal or extra large size works best for me)*

*1 bottle of KC Masterpiece Caribbean Jerk Marinade*

*Wood chips (Since the shrimp cook fast, mesquite is best to get a real smoky flavor, but any wood can be used with good results)*

Place thawed and rinsed shrimp into a gallon size food storage bag. Pour entire bottle of marinade into bag. Refrigerate for 2 hours. Place wood chips in the Orion Cooker. Light the cooker and wait for the wood chips to produce heavy smoke. Place the shrimp onto 2 grates. Use the middle and top locations for cooking, and the bottom grate to catch the ones that fall through. Place the grates in the cooker and close the lid. Lift the lid after 8 minutes to check for doneness. The shrimp are done when the tail turns pink and the body has changed from gray to white/pink. If overcooked, they become a little tough and rubbery, so check often. These are also great re-heated.

Larry Bradshaw  
Pontiac, Illinois

---

## **Bru's 2-Meat — Turkey n Pork**

*12 lb Turkey*

*5 lb Pork Loin (cut into 2 chunks)*

*Lawry's Seasoned Salt*

*Garlic Salt*

*Tony Chachere's Cajun Seasoning*

*Paprika*

Coat both the Turkey and the Pork Loin with all 3 seasonings. Sprinkle Paprika inside the Turkey cavity. Add wood chips between cooking cylinder and drip pan. (I used mesquite wood chips first time and on another occasion used apple wood chips. Both worked great.) Place the Turkey on the Poultry Post and stand it inside the Orion Cooker. Place 1 chunk of the Pork Loin on the middle rack and the other chunk on the top rack. Add charcoal to both the upper and lower charcoal rings. Light and come back in 2 hours. Check both meats for doneness with thermometer.

(I used a remote thermometer in the Pork Loin and fed it through one of the screw holes for the rib hanger receptacles. When I removed the meat at 2 hours, the temperature was 125 degrees. Before serving, I put both type of

meats in pre-warmed crock pots, sealed them with tin foil and let set for an hour on warm before carving.)

Jeff Brubaker  
Hamler, OH

---

### **Bru's 3-Meat (Turkey 'n Pork 'n Rib Roast)**

*Three 2 lb Turkey Breasts*  
*One 5 lb Pork Loin (cut into 2 chunks)*  
*One 8 lb Rib Roast (not completely thawed)*  
*Lawry's Seasoned Salt*  
*Garlic Salt*  
*Tony Chachere's Cajun Seasoning*

Coat the Turkey, Pork Loin, and Rib Roast with all 3 seasonings. Add wood chips between cooking cylinder and drip pan (I used apple wood chips). Place the Rib Roast inside the drip pan. Place 1 chunk of the Pork Loin on the lower rack and the other chunk on the middle rack. Place one Turkey Breast on each of the 3 Rib Hangers. Add charcoal to both the upper and lower charcoal rings. Light and come back in 2 hours. Check both meats for doneness with thermometer.

(I used a remote thermometer in the Rib Roast and fed it through one of the screw holes for the rib hanger receptacles. I placed the remote thermometer in the Rib Roast. The internal temperature was 27 degrees. (I had placed the Rib Roast in the refrigerator 2 days before to thaw but it was still frozen when I removed it. Worked out in the end) It took 1 hour for the temperature to go up one degree. From there on it shot up pretty quick, around a degree a minute at times. I removed the Turkey Breasts and Pork Loin at 2 hours. The temperature of the Pork Loin was 125 degrees. I removed the Pork Loin 40 minutes later at a temperature of 145 degrees. I put all three types of meats in pre-warmed crock pots and sealed with tin foil. I let them all set for an hour on warm before carving.)

Jeff Brubaker  
Hamler, OH



## Wood Chip Recommendations

- ALDER WOOD CHIPS . . . . . Use with salmon
- APPLE WOOD CHIPS . . . . . Use with poultry, pork sausage, pork and lamb
- APRICOT WOOD CHIPS . . . . Use with fish, shrimp, chicken, and pork
- CHERRY WOOD CHIPS . . . . Use with pork, chicken and turkey
- HICKORY WOOD CHIPS . . . . Use with pork, turkey, chicken for smoking  
brisket and ribs
- LEMON WOOD CHIPS . . . . . Use with salmon, turkey, chicken and pork
- MAPLE WOOD CHIPS . . . . . Use with turkey, chicken, pork when smoking  
brisket or ribs
- MESQUITE WOOD CHIPS . . . . Use with beef
- PEACH WOOD CHIPS . . . . . Use with, pork and chicken
- PEAR WOOD CHIPS . . . . . Use with pork, turkey and chicken
- PECAN WOOD CHIPS . . . . . Use with pork

## Meat Doneness Table

### Veal, lamb and beef

- Medium Rare . . . . . 145 degrees
- Medium. . . . . 160 degrees
- Well Done . . . . . 170 degrees

### Pork

- Medium. . . . . 145 degrees
- Well Done . . . . . 170 degrees

### Poultry

- . . . . . 180 degrees

## Frequently Asked Questions:

1. *Are there any flames on the inside of the Orion Cooker®?*

No, the heat source comes from coals located at two areas on the outside of the cooker.

2. *What does the fire on the top of the cooker accomplish?*

The fire on the top is part of the patent pending cooking technology that produces the convection current inside the cooking cylinder.

3. *Do the handles on the lid get hot?*

No, the handles are made out of coiled steel which dissipates heat. They are similar to handles found on a “Dutch oven”.

4. *Where are the chips placed that provide the smoke?*

The chips are placed between the drip pan and the inside wall of the cooking cylinder. The heat from the charcoal in the lower charcoal ring causes them to smoke when they are up against the inside wall of the cooking cylinder. Do not place wood chips underneath the drip pan.

5. *What are the attachments constructed out of—stainless steel or aluminum?*

The attachments are manufactured out of food grade stainless steel. They are dishwasher safe, will not rust and very sturdy.

6. *What comes with the Orion Cooker when it is purchased?*

The unit is delivered with three attachments: three rib hangers, three cooking grates and a turkey post and lifting handle. Along with the attachments, you will receive a cookbook and cooking manual that will walk you through all of the steps while cooking on the Orion Cooker.

7. *How do you remove the ashes from the cooker?*

To remove the ashes from the lower ring, simply slide the ash door out and start scraping the coals out with the door. We recommend that you purchase a tin pan to scrape the used ashes into.

8. *How do you know when the food is done?*

The cook times for the product will be listed in the cookbook/manual. These times are accurate; however, please check all meat with a thermometer to ensure that it is done.

9. *What type of steel is the Orion Cooker made out of?*

The Orion Cooker and all of the attachments are 100% food grade stainless steel. After using the Orion Cooker several times, the steel will begin to darken. This is due to the smoke on the inside of the cooking cylinder as well as the heat/ash from the coals on the outside. This will in no way diminish the quality or performance of the Orion Cooker.

10. *Do I need to soak wood chips prior to cooking/smoking?*

No the wood chips do not need to be soaked. The cooking cylinder is completely enclosed so very little smoke will escape from the cylinder. The chips will not need to be replaced, they will last the duration of the cook.

11. *Can you put liquid in the drip pan or does it have to stay dry?*

We only recommend adding liquid to the drip pan for beef briskets, fish and seafood. Because the meat is completely enclosed in the cooking cylinder, moisture from the meat drips down into the pan causing it to steam and preventing it from drying out.

12. *Do I need to cook on the Orion Cooker prior to cooking any product?*

It's not necessary, however, we do strongly recommend washing all accessories prior to cooking with them.

13. *Should I wash the attachments prior to the first cook on the Orion Cooker?*

Yes. We recommend that you wash all of the attachments prior to cooking any meat on the Orion Cooker. All of the attachments are dishwasher safe. So we recommend that prior to the first cook with meat, that you wash all of the attachments in the dishwasher.

14. *Do you recommend instant light charcoal or regular charcoal?*

We recommend that you use instant light charcoal. This will make the cooking process easier. Also, the cook times will be more accurate using instant light charcoal.

15. *If I remove the lid before the designated time, will this affect the cooking?*

Yes. If you remove the lid before the designated cook time the cook times will be affected. This will disrupt the convection current and allow the heat to escape the cooking cylinder.

16. *Does cold effect the cook times?*

Not to our knowledge. Orion Cooker has cooked in temperatures ranging from 35-40 degrees and there was no change in the cook time.

17. *Does wind effect cooking on the Orion Cooker?*

Yes. Substantial winds will cause the briquettes to burn faster then normal. In this situation, additional coals might be needed to complete the cook.

## **Remember—LOAD, LIGHT EAT!**

**NOTES:** \_\_\_\_\_

\_\_\_\_\_

\_\_\_\_\_

\_\_\_\_\_

\_\_\_\_\_

\_\_\_\_\_

\_\_\_\_\_

\_\_\_\_\_

\_\_\_\_\_

\_\_\_\_\_

\_\_\_\_\_

\_\_\_\_\_

\_\_\_\_\_

\_\_\_\_\_

\_\_\_\_\_

**NOTES:** \_\_\_\_\_

\_\_\_\_\_

\_\_\_\_\_

\_\_\_\_\_

\_\_\_\_\_

\_\_\_\_\_

\_\_\_\_\_

\_\_\_\_\_

\_\_\_\_\_

\_\_\_\_\_

\_\_\_\_\_

\_\_\_\_\_

\_\_\_\_\_

\_\_\_\_\_

\_\_\_\_\_

\_\_\_\_\_

\_\_\_\_\_

\_\_\_\_\_

\_\_\_\_\_

\_\_\_\_\_

\_\_\_\_\_

\_\_\_\_\_

\_\_\_\_\_

Share the Orion  
Experience  
with friends.

Visit us online:  
[www.theorioncooker.com](http://www.theorioncooker.com)



**Orion Cooker**

[www.TheOrionCooker.com](http://www.TheOrionCooker.com)

1 (866) 891-3663



**Orion Cooker**

[www.TheOrionCooker.com](http://www.TheOrionCooker.com)

1 (866) 891-3663



**Orion Cooker**

[www.TheOrionCooker.com](http://www.TheOrionCooker.com)

1 (866) 891-3663



**Orion Cooker**

[www.TheOrionCooker.com](http://www.TheOrionCooker.com)

1 (866) 891-3663

To find recipes, replacement parts and accessories,  
or participate in Orion's online community visit:

[www.theorioncooker.com](http://www.theorioncooker.com)



The Orion Cooker is a meat smoker and convection cooker that produces moist tender meat in less time than a traditional bbq smoker.



Orion Outdoors • PO BOX 250401 • Atlanta, GA 30325

[sales@theorioncooker.com](mailto:sales@theorioncooker.com)