

RADIODETECTION®

RD500

Water pipe locator kit

Operation Manual

90/RD500-OPMAN-MET/01



Before you start

Thank you for your interest in Radiodetection's RD500 Plastic Pipe Locator Kit

Please read this user manual in its entirety before attempting to use the RD500 system as it contains many important safety notices and warnings.

Radiodetection products, including this manual, are under continuous development. The information contained within is accurate at the time of publication; however the RD500, this manual and all its contents are subject to change.

Radiodetection Limited reserves the right to modify the product without notice and some product changes may have taken place after this user manual was published.

Contact your local Radiodetection dealer or visit www.radiodetection.com for the latest information about the RD500 product family, including this manual.

Read this manual in its entirety before attempting to operate the RD500. Note all safety notices in the preface and throughout this manual.

 **WARNING:** Failure to comply with safety warnings can cause serious injury or death.

CAUTION: Failure to comply with safety cautions can result in damage to equipment or property.

This equipment shall be used only by qualified and trained personnel, and only after fully reading this Operation Manual.

You are responsible for determining whether the conditions are suitable for using this device. Always carry out a risk assessment of the site to be inspected.

Follow your company and national safety procedures and or requirements when operating this equipment in any environment or workplace. If you are unsure what policies or procedures apply, contact your company or site's occupational health and safety officer or your local government for more information.

Do not use this equipment if you suspect that any component or accessory is damaged or faulty.

Use authorized accessories only. Incompatible accessories may damage the equipment or give inaccurate readings.

Keep this equipment clean and arrange for regular services with an authorized Radiodetection service center.

Headphone use: you need to remain alert to traffic and other hazards that are normally heard outdoors. Always turn the volume down before plugging headphones into an audio source and use only the minimum level, necessary to take your measurements. Excessive exposure to loud sounds can cause hearing damage.

Do not attempt to open or dismantle any part of this equipment unless directed specifically by this manual. Doing so may render the equipment faulty and may void the manufacturer's warranty.

You are responsible for determining whether you consider the measurement results to be valid and for any conclusions that are reached or any measures that are taken as a result thereof. Radiodetection can neither guarantee the validity of any measuring results nor can we accept liability for any such results. We are on no account able to accept liability for any damage which may be caused as a consequence of the use of these results. Please see the Standard Warranty Terms enclosed with the product for further information.

Training

Radiodetection provides training services for most Radiodetection products. Our qualified instructors will train equipment operators or other personnel at your preferred location or at a Radiodetection location.

For more information go to www.radiodetection.com or contact your local Radiodetection representative.

Section	Title	Page
	INTRODUCTION	
	PART 1 - OPERATING GUIDE	5
1.0	Unpacking and Setup	5
2.0	Fast Start Guide	5
3.0	Pulse Transmitter Application Techniques	6
4.0	Locator Application Techniques	7
5.0	Locator & Adapter Kit Details	8
5.1	Locator Kit Details	8
5.2	Sprinkler/Hose Bib Kit Details	9
5.3	Fire Hydrant Kit Details	9
5.4	RD500-Tx Electronic Pulse Transmitter	10
5.5	Water Meter Kit Details	10
	PART II - TROUBLESHOOTING GUIDE	
1.0	Introduction	11
2.0	Pulse Transmitter Repairs	11
2.1	Purpose of the Pulse Transmitter	11
2.2	Pulse Transmitter Fault Analysis	11
2.2.1	Pulse Transmitter Tests	13
2.2.1.1	Clogged Inlet Filter	13
2.2.1.2	Leak Tests	14
2.2.1.3	Spring Inspection	14
2.2.1.4	Operational Tests	14
2.2.1.5	Pulse transmitter failure symptoms	16
3.0	RD500 Locator Repairs	16
3.1	Purpose of the Locator	16
3.2	Locator Fault Analysis	16
3.2.1	Locator Tests	17
3.2.1.1	Battery Test	17
3.2.1.2	Locator Sensitivity Test	18
3.2.1.3	Operational Tests	19
3.3	Locator Cleaning, Inspection & Repair	20
	RD500 THEORY	21
1.0	Vibration	21
2.0	Stage I: Water Flowing	22
3.0	Stage II: Pressure Wave Created	23
4.0	Stage III: Pressure Wave is Reflected	24
5.0	Stage IV: Pulse Transmitter Flow is Re-established	25
6.0	Seismic Disturbance	26
7.0	RD8100 Response vs. RD500 Response	27
8.0	RD500 Operating Parameters	28
9.0	Expectations	28

List of Figures & Tables

Figure	Title	Page
PART 1 - FIGURES		
5.1	Locator Kit Details	8
5.2	Sprinkler/ Hose Bib Kit Details	9
5.3	Fire Hydrant Kit Details	9
5.4	RD500-TX kit details	10
5.5	Water Meter Standpipe Kit Details	10
PART II - FIGURES		
2.1	Pulse Transmitter Photograph	11
2.2	Pulse Transmitter Simplified Block Diagram	12
3.1	Locator Photograph	17
3.2	RD500 Theory and use	21
LIST OF TABLES		
Table 2.1	Pulse Transmitter Type Summary	13
Table 2.2	Pulse Transmitter Failure Symptoms & Causes	15
Table 2.3	RD500-Tx Failure symptoms & Causes	16
Table 3.1	Locator Failure Symptoms & Causes	19

INTRODUCTION

Thank you for purchasing the most cost-effective plastic pipe locator tool available. The purpose of this manual is to provide useful information that will help you get the best possible results from your new locator. This operating guide contains directions for unpacking, setting up and operating the RD500 system. It also contains a fast start guide that will enable users to quickly begin locating water pipes. This is followed by more detailed instructions for obtaining better results with the Pulse Transmitter and the Locator

PART I - OPERATING GUIDE

1.0 Unpacking and Set-up:

Your RD500 Locator comes packaged in a special carrying case that has compartments for the Locator with spike installed, a hard surface plate and the headphones. Each kit that you order is pre-assembled and ready for use. Please keep all packaging materials in case it becomes necessary for you to return any of your equipment. The following items should be checked as you unpack your system.

LOCATOR: The Locator is supplied with a 9-volt battery and ground spike installed. A hard surface plate and headphones are also included along with this operation manual. If any items are missing please contact your Radiodetection supplier immediately.

PULSE TRANSMITTER KITS: Each Pulse Transmitter adapter kit comes fully assembled and ready for use. A detailed drawing of each Adapter Kit is contained in Section 5.0 of the Operational Manual. . If any items are missing please contact your Radiodetection supplier immediately.

2.0 Fast Start Guide:

Detailed operating instructions are also included on the side of the Locator. These instructions are repeated her for your convenience:

Pulse Transmitter Operating Instructions:

1. Remove protective caps from Pulse Transmitter
2. Connect Pulse Transmitter to nearest water outlet using kit supplied with Pulse Transmitter
3. Turn on water and loosen adjustment lock nut near T-handle
4. Turn T-handle clockwise until water flows
5. Turn T-handle anticlockwise until water pulses several times per second; tighten lock nut

Locator Operating Instructions:

1. Turn ON/ OFF knob clockwise to activate
2. Initial meter reading indicates battery condition
3. To replace battery, loosen battery release button, move housing upward to expose battery

4. Begin initial tracing about 2 metres from Pulse Transmitter or any other area where pipe location is known
5. Push spike of Locator into ground near known pipe location and turn ON/ OFF knob clockwise for mid-range meter reading and adjust individual headphone controls for comfortable listening level
6. To pinpoint pipe position, use Locator to probe ground until you find peak (maximum) meter reading. You will also hear the pulsing sound (similar to a heartbeat) grow louder
7. Trace the pipe by establishing the direction of pipe route by probing every one to two meters to locate a peak meter reading. Adjust the ON/ OFF knob to maintain a mid-range meter reading

Notes and Precautions:

- The RD500 is for use on water pipes only
- It works best on water pressures in the range of 3 to 7 Bars; maximum pressure 10 Bars
- The Pulse Transmitter pulsating effect causes pipe movement. If used for extended periods or on substandard plumbing systems, leaks may result

Additional Notes and Precautions:

1. RD500 readings do not indicate depth and the RD500 does not detect buried electrical power lines, gas lines or other hazardous underground objects, so always dig carefully in the proximity of buried pipes or cables
2. Use caution while wearing headphones and be alert to traffic or other hazards that are normally heard outdoors
3. Always stand clear of all Pulse Transmitters, adapter kits and hoses while they are connected to water systems and operating
4. On all hose bib applications, within 15 metres of a building, the proper low-power Pulse Transmitter (GREEN) or RD500-Tx electronic Pulse Transmitter and Tap damper MUST be used

3.0 Pulse Transmitter Application Techniques:

Pulse Transmitters are connected at sprinkler heads, hose bibs, water meter bases, fire hydrants and clean-outs. Supplied Pulse Transmitters using the adapter kits are illustrated in Section 5.0 of the Operational Manual. Always flush any connection site until the water that flows is clear of all rust, silt, sealing compounds and foreign materials before connecting a Pulse Transmitter to the water line.

Refer to Section 5.0 for a detailed description of the Locator kit and the adapter kits that are available. All adapter kits are supplied with a Tap damper, tap, couplings and a 3 metre high-pressure drain hose that must be connected to the outlet of the Pulse Transmitter in order for the device to work properly. Always use a weight on the hose or tie the hose down to prevent the hose from whipping.

Check the water pressure before attempting to locate the water line and make sure that it is in the operating range of the Pulse Transmitter, which is 3 to 10 Bars (40 to 140 psi).

The Pulse Transmitters are color-coded to identify their intended usage: A color-coded ty-wrap is used along with a small square area that is painted on the side of the Pulse Transmitter to indicate the color. Green is the lowest power Pulse Transmitter and is intended for use on sprinkler and hose bib pipes that typically range in diameter between 1.3cm and 5cm. Green Pulse Transmitters may be used on larger diameter pipes where reduced operating range is acceptable. Yellow Pulse Transmitters are intended for use on water mains that range in diameter between 5cm and 15cm. They are typically connected at a water meter connection. Yellow Pulse Transmitters should never be used on smaller diameter pipes, but they may be used on larger diameter pipes. Red Pulse Transmitters are intended for use only on water mains that are 15cm in diameter or larger. The typical connection is via a fire hydrant.

Always start your adjustments by turning the T-handle clockwise until full water flow is attained at the Pulse Transmitter outlet. Then, slowly turn the T-handle anticlockwise until the Pulse Transmitter begins to pulse. Once the pulsing begins, turn the handle very slowly in each direction to fine tune the pulse to a regular beat of about two to five times per second. This adjustment range varies between less than one turn to several turns depending on the operating conditions. If you turn the T-handle too far in the clockwise direction, water will flow continuously without pulsing, and if you turn the T-handle too far in the anticlockwise direction, water flow will stop completely.

The best results are obtained with the slowest pulse possible. Range and signal strength are greatly improved with low pulse rates of a few pulses per second. Higher water pressures typically cause faster pulse rates. Pulse rates above 10 pulses per second are difficult to use and cause reduced location range.

The Pulse Transmitter contains a locking collar located directly below the T-handle. Tighten the hex-shaped collar to prevent the T-handle from moving (walking) while pulsating.

4.0 [Locator Application Techniques:](#)

Two devices are provided for probing the surface with the RD500 Locator. A 14cm ground spike is supplied for soft surfaces and a brass hard surface plate is included for hard surfaces such as concrete or tarmac (asphalt). The hard surface plate has concentric recessed channels in its surface that allow it to be positioned such that it lays flat against surfaces.

The RD500 is supplied with high quality headphones that have independent volume adjustments on each ear piece. Using non-standard headphones may reduce system performance, create oscillation in the audio output and cause mechanical damage to the headphone jack.

Pinpointing pipe location is difficult without using the meter to measure signal level. It is very difficult for the average person to discern slight variations in audio signal levels. Always adjust the sensitivity so as to maintain a mid-scale meter reading while locating. Typical location accuracy is plus or minus one pipe diameter. Always probe or expose the pipe to confirm the exact location before performing any excavation.

Best location results are obtained by beginning your tracing at least 3 metres from the location where the Pulse Transmitter is connected. The signal levels are normally too strong in the area immediately surrounding the Pulse Transmitter. Alternately, tracing may begin at a known pipe location that is not more than 75 metres down the pipe from the Pulse Transmitter.

The preferred method for tracing pipes is to locate at least two known pipe locations that indicate the heading or direction that the pipe is laid. Readings should be taken along an imaginary line that runs perpendicular to the pipeline. Confirm a peak signal reading by taking additional readings that are equal distances from the peak location. These readings should be lower than the peak reading and approximately equal.

Once the pipe direction is determined, it is possible to quickly trace the pipe along this heading and confirm any changes in direction by periodically taking readings.

Always transport and store your Locator in the carrying case to protect it from damage. If the Locator is allowed to fall over and strike a hard surface it may permanently damage the meter.

5.0 Locator and Adapter Kit Details:

The Locator kit, sprinkler/ hose bib kit, fire hydrant kit and water meter kit details are supplied for your reference in identifying and maintaining the equipment.

5.1 Locator Kit Details:



5.2 Sprinkler/ Hose Bib Kit Details:



5.3 Hydrant Standpipe Kit Details:



5.4 RD500-Tx Electronic Pulse Transmitter Kit

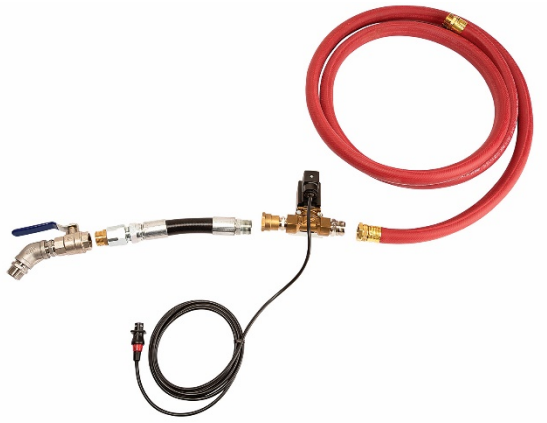

5.5 Water Meter Standpipe Kit details



PART II - TROUBLESHOOTING GUIDE

1.0 Introduction:

This part of the manual is divided into two major subjects. Section 2 covers the Pulse Transmitter and Section 3 covers the Locator. Each section is organized to first provide an overview of the equipment and its major components. This is followed by a set of tests that can be performed by the user to locate problems.

2.0 Mechanical Pulse Transmitter Repairs: (Red, Yellow or Green models)

2.1 Purpose of the Pulse Transmitter:

The Pulse Transmitter creates the signal that is picked up by the Locator. The Pulse Transmitter creates this signal by automatically opening and then rapidly closing a water valve, which allows water to alternately flow out of a pipe for a short period of time and then be quickly stopped for a short period of time. This rapid interruption of water flow, on a regular basis, creates pressure changes inside the water pipe. These pressure changes travel along the pipe as waves and cause slight motion in the walls of the water pipe. The Locator picks up this pipe motion at the ground surface and indicates signal levels to the user. The user locates the underground pipe by finding the maximum (peak) signal level on the surface.

2.2 Fault Analysis:

The Pulse Transmitter is a special water valve that operates in the fully open condition (water flowing from the outlet) or the fully closed condition (no water flow). Figure 2.1 (below) is a photograph that illustrates the location of the principal parts of the Pulse Transmitter. Externally, the Pulse Transmitter has two protective caps, a female thread (water inlet) a male water outlet and a T-handle adjustment, which allows the device to operate over a wide range of water pressures. The serial number for the Pulse Transmitter is located on a small tag on the side of the Pulse Transmitter.

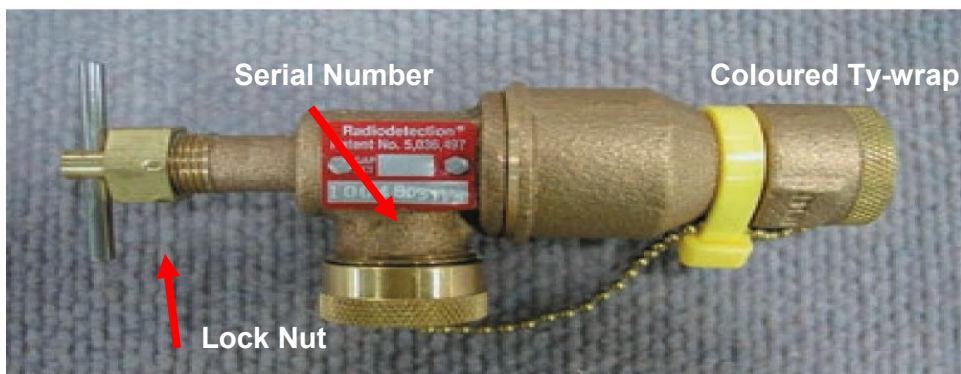
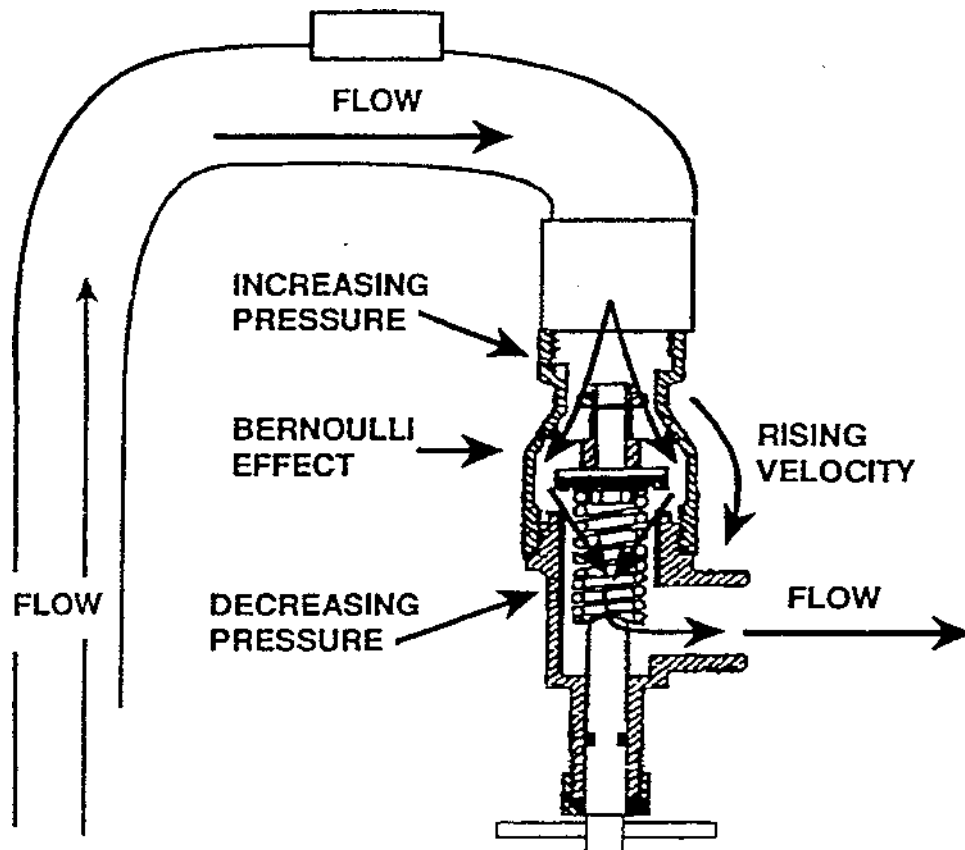

Figure 2.2 Pulse Transmitter Simplified Block Diagram

Figure 2.2 is a simplified block diagram of the Pulse Transmitter illustrating the operation of the valve. Valve opening and closing is controlled by the adjustable T-handle. Turning the handle clockwise increases the spring force and causes the valve to open (water starts flowing), while rotating it anticlockwise reduces the spring force allowing it to close (water stops flowing). A handle setting between these extremes will allow the valve to open and then close on a regular basis at a rate of about 2 to 5 pulses per second.

Pulse Transmitters are factory calibrated to provide specific water flow rates. Flow rates are generally expressed in liters per minute (or gallons per minute).

NOTE: Special test equipment is required to calibrate Pulse Transmitters. Internal Pulse Transmitter adjustments must not be attempted by users. Any such adjustments will void the equipment warranty and may result in damage to the attached pipe systems.



Larger diameter pipes require higher flow rates to produce a strong signal output. The three types of Pulse Transmitters currently offered are summarized in Table 2.1 below:

Table 2.1 - Pulse Transmitter Type Summary

Power/ Color Code	Diameter of Pipe	Service Type
Low / GREEN	≤ 5cm	Service and Sprinkler lines
Medium / YELLOW	> 5cm	Small Water Main
High / RED*	> 15cm	Large Water Mains

***CAUTION: RED PULSE TRANSMITTERS SHOULD ONLY BE USED ON FIRE HYDRANTS**

You can determine the type(s) of Pulse Transmitters you have by examining the color coding used on the cable tie that holds the dust caps onto the body and the color painted on the square area opposite the tag on the Pulse Transmitter body.

2.2.1 Pulse Transmitter Tests:

The following tests can be easily performed by a user to help determine if a problem(s) exists in a Pulse Transmitter. Please see Figure 2.1 to clarify the location of specific parts.

2.2.1.1 Clogged Inlet Filter:

Check the filter washer screen (located inside the inlet of the Pulse Transmitter) for debris. Remove and clean if dirty. Replace filter washer if screen is damaged in any way. Be sure to only use filter washers approved by Radiodetection and to install the screen with the cone pointing outward as shown in Figure 2.3.

CAUTION: Do not substitute a washer with a coarser filter screen or no filter screen at all as this will likely cause your Pulse Transmitter to become contaminated internally and result in premature failure of the valve seats.

2.2.1.2 Leak Tests:

1. Connect the Pulse Transmitter to the appropriate water pipe using all of the adapter kit provided. DO NOT connect the water hose to the Pulse Transmitter outlet during this test.
2. Turn the water fully on and turn the T-handle on the Pulse Transmitter anticlockwise until water stops flowing completely.
3. Observe the area around the inlet of the Pulse Transmitter. If any leaks occur, check the inlet filter screen washer for cracks or damage and replace if necessary. The Pulse Transmitter will not operate properly if leaks exist around the inlet. If the inlet has been crushed or bent, the Pulse Transmitter must be returned to Radiodetection for repair.
4. Examine the upper Pulse Transmitter body and make sure no leaks are occurring in the body or around the seal between the upper and lower Pulse Transmitter bodies. If leaks appear around the "O" Ring seal or if the body is leaking, return the Pulse Transmitter to Radiodetection for repair.
5. Look at the Pulse Transmitter outlet and make sure no water leaks occur at the outlet. A few drops per minute from the outlet is acceptable. If a steady leak occurs, return the Pulse Transmitter to Radiodetection for repair.
6. If no leaks are present in any of the tests described above, proceed to the tests described below.

2.2.1.3 Spring Inspection:

1. Disconnect the Pulse Transmitter from the water pipe and rotate T-handle anticlockwise until the spring located inside the Pulse Transmitter is loose. The spring should rattle when the Pulse Transmitter is shaken. The spring can be observed by looking into the outlet of the Pulse Transmitter.
2. Look into the outlet and examine the spring for signs of wear or breakage. If worn or broken, return the Pulse Transmitter to Radiodetection for repair.
3. Rotate the T-handle clockwise, watch the spring through the outlet as it is compressed and look for wear or breakage. Look at the brass spring button on the end of the spring that rides on the threaded handle shaft and make sure it is in place. If any problems are found, return the Pulse Transmitter to Radiodetection for repair.

2.2.1.4 Operational Tests:

1. Connect the Pulse Transmitter to the appropriate water pipe using all of the adapter kit provided. Connect the supplied, high pressure water hose to the Pulse Transmitter outlet during this test and remember to restrain the hose so that the pulsing does not cause it to whip.

2. Turn the water fully on (open valve completely).
 3. Loosen the T-handle collar (knurled ring or hex-shaped collar just above T-handle). Turn the T-handle on the Pulse Transmitter clockwise until water starts flowing through the water hose on the outlet.
 4. Slowly turn the T-handle anticlockwise until the Pulse Transmitter starts to pulse.
 5. Turn the T-handle clockwise until the pulsing stops and observe its position (rotational location) and then turn the T-handle anticlockwise again until you observe the slowest pulse rate. The target rate is about 2 to 5 pulses per second and the rate should increase slightly as you turn the T-handle clockwise. Observe the Pulse Transmitter operation for a few minutes to make sure that it runs smoothly and then lock the T-handle by tightening the T-handle collar with pliers or a wrench.
- The collar puts friction on the T-handle shaft, to prevent it from turning (walking) due to the vibration, which will cause the Pulse Transmitter to stop pulsing. Continue to watching the Pulse Transmitter to make sure the T-handle does not turn and that the Pulse Transmitter continues to pulse at a regular rate. Re-tighten the collar if the T-handle moves.
6. If the Pulse Transmitter does not run smoothly at about 2 to 5 pulses per second, compare the results with the following table:

Table 2.2 – Mechanical Pulse Transmitter Failure Symptoms and Causes

SYMPTOM OBSERVED	LIKELY CAUSE (S)
Water runs continuously and Pulse Transmitter will not pulse regardless of T Handle position	Pulse Transmitter is being held open by a foreign object or is damaged
Water runs, the Pulse Transmitter operates for a few seconds as T-Handle is turned , then water stops flowing	T-Handle is being turned anticlockwise too quickly. Try turning it clockwise until water starts flowing, then start turning the T-Handle slowly anticlockwise until the Pulse Transmitter starts operating.
Pulse transmitter operates too quickly	Make sure the High pressure hose is connected to the outlet of the Pulse transmitter and that the adaptors and tap damper hose are all connected tightly
Pulse Transmitter stops operating after running for a few minutes	Make sure the locking nut on the Spring housing is tight enough to stop the T-Handle from vibrating loose and turning.
Pulse Transmitter operation in interrupted periodically by continuous water flow	This is caused by water pressure variations in the plastic pipe being located. Try turning the T-Handle slowly anticlockwise until a continuous pulse is achieved.

Table 2.3 RD500-Tx. Electronic Pulse transmitter failure symptoms and causes

SYMPTOM OBSERVED	LIKELY CAUSE (S)
No pulse from electronic Pulse transmitter when Power is switched on	Battery flat , Check indicator on RD500-Tx power Control unit Check 12v DC supply is connected

3.0 RD500 Locator Repairs

3.1 Purpose of the RD500 Locator:

The RD500 Locator picks up the signal created inside the pipe by the Pulse Transmitter. The Pulse Transmitter creates this signal by automatically opening and then rapidly closing a water valve. This allows water to alternately flow out of a pipe for a short period of time and then be quickly stopped for a short period of time. This rapid interruption of water flow, on a regular basis, creates pressure changes inside the water pipe. These pressure changes travel along the water pipe as waves and cause slight motion in the walls of the pipe. This pipe motion travels through the ground and causes similar motion at the surface of the earth. The Locator uses a motion sensor to pick up this pipe movement at the surface and indicates signal level to the user. The user locates the underground pipe by finding the maximum (peak) signal level on the surface of the ground.

3.2 RD500 Locator Fault Analysis:

Figure 3.2 is a photograph of the Locator illustrating the location of principal parts. The motion sensor is located inside the pole in the area just above the spike. The Sensor is sealed inside the pole and can only be serviced by Radiodetection. The Sensor is connected to the electronics by a cable that runs through a foam insert to a connector located directly below the battery. This connector allows the lower pole assembly to be separated from the movable upper control housing assembly, which contains the meter, the electronic cards and the controls. The battery housing is permanently attached to the lower pole assembly just above the handle grip. It contains "O" Rings, which slide inside the control housing to seal the unit. The serial number of the RD500 Locator is located on the Locator pole decal.

Located inside the control housing on the rear side are the ON/ OFF Sensitivity Switch and the BATTERY COMPARTMENT knob. A knob lock mechanism is contained directly below the ON/ OFF Sensitivity Switch. Located on the front side of the housing is the HEADPHONE JACK and a black plastic rivet which keeps the control housing attached to the pole assembly. Two electronic cards are mounted on the back side of the meter and the meter assembly is held inside the control housing by four self-tapping screws. A rubber gasket is located under the meter to

seal the upper control housing and a decorative black bezel is installed over the face of the meter. The meter assembly is connected to the control housing by a single 8-pin connector.

3.2.1 RD500 Locator Tests:

The following tests can be easily performed by a user to help determine if a problem(s) exists in the RD500 Locator. Please see Figure 3.2 to clarify the location of specific parts.

3.2.1.1 Battery Tests:

The RD500 Locator battery may be tested by turning the ON/ OFF Sensitivity Switch clockwise until the needle on the meter moves and indicates the battery condition. The needle should register the GREEN battery zone. If the battery test fails, turn the RD500 back to off and open the battery compartment by turning the battery button anticlockwise until it pops up. The button is located just above the handle grip on the back side of the pole. Slowly slide the control housing upward to expose the battery as shown in Figure 3.3. Pull the 9-volt battery out of the compartment, disconnect the battery from the connector and replace the battery with a new alkaline 9-volt battery. **Make sure that the battery cable and the sensor cable are located on the right side of the battery when viewed from the front and not located underneath the battery. The battery will not fit properly into the housing if any of the cables are located under the battery.**

1. If battery was replaced, repeat the battery test described above and confirm that the needle registers in the green zone. If it does not, check the battery connections and make sure they are installed properly.
2. If the needle does not move at all when the ON/ OFF switch is activated, turn the Sensitivity Switch fully clockwise and tap the pole with your finger. The meter should register in the green zone when you tap the pole.
3. If the meter still does not move, turn the ON/ OFF Switch to OFF and shake the upper control housing assembly while watching the meter needle. If the meter needle will not move when shaken, then the meter movement is damaged and will have to be returned to Radiodetection for repair.



3.2.1.2 Locator Sensitivity Tests:

Each RD500 Locator Assembly is calibrated at the factory to produce specific meter signal levels when the complete assembly is tested with a platform that produces controlled levels of motion. The following test can be conducted without special equipment to determine if your Locator has sensitivity problems and should be returned to Radiodetection for repair.

NOTE: the ON/ OFF SENSITIVITY Switch (located directly above the battery compartment button) controls power application to the Locator and the signal level displayed on the meter and heard on the headphones.

CAUTION: It is very important that only the headphones supplied and approved by Radio-detection be used with the RD500 Locator. Certain low-cost headphones produce lower audio outputs and cause the Locator electronics to malfunction. These headphones will reduce the listening level and may cause the electronics to oscillate at high sensitivity levels.

1. Plug the APPROVED headphones into the jack on the front of the Locator and turn the ON/ OFF Sensitivity Switch to the ON position. Observe the battery check and make sure the meter registers in the green zone as described in Section 3.2.1.1. If the battery test fails, replace the battery and re-test the Locator before proceeding with the sensitivity test.
2. Make sure the spike is attached tightly to the lower portion of the pole as a loose spike will reduce the sensitivity of the Locator.
3. Find a “quiet” location to perform these tests that is protected from strong winds and away from roads, sidewalks, railroad tracks, power transformers and moving machinery. The location chosen should allow the Locator spike to be pushed into the ground so it will stand up without being held.
4. Turn the Locator on and increase the sensitivity level to its maximum position.
5. Take your hands off of the Locator, stand completely still and listen to the headphones and look at the meter. If the headphones supplied have an adjustable listening level, adjust to a comfortable level.
6. The Locator meter should indicate a level below 10% and the headphones should be quiet. If the meter registers above 10%, you should hear the signal on the headphones. Try and identify the source of the signal and move to an alternate test site if the level is above 10%.
7. While standing still, carefully tap the Locator on the peak of the bezel (just above the meter) with one finger while watching the meter and listening to the headphones. When tapped gently, the meter should move quickly to a mid-range level and you should hear the tapping sound in the headphones. If you tap the Locator a little harder, the meter should easily read full scale (top of the green zone) and be heard loudly.
8. If you cannot easily make the meter read half scale and hear the signal clearly when it is tapped, then the Locator should be returned to Radiodetection for testing.

9. If the meter does not return below 10% quickly after being tapped, and you hear a tone, then the Locator is breaking into oscillation and may need to be returned to Radiodetection for repair.

10. If a tone (oscillation) is heard, try reducing the sensitivity by turning the knob anticlockwise about 1/4 turn. If this does not help, watch the meter and observe its response when oscillating, then try disconnecting the headphones and repeating the test. If the Locator continues to oscillate, then it must be returned to Radiodetection for repair.

3.2.1.3 Operational Tests:

11. Connect the proper Pulse Transmitter to the water pipe as directed in the Operating Guide and adjust it to produce a good signal as directed in Section 2.2.1.5, Pulse Transmitter Operational Tests.

12. Move a few feet away from the Pulse Transmitter and probe the ground with the Locator. You should be able to pick up the signal easily with the sensitivity level at a low setting (less than 1/4 urn).

13. If the Locator does not operate properly, compare the results with the following table:

Table 3.1 - Locator Failure Symptoms and Causes

SYMPTOM OBSERVED	LIKELY CAUSE (S)
Meter does not move on battery test or during operation, but signal is heard on headphones	Meter movement is damaged and stuck in one position. Return it to Radiodetection for repair
Meter moves but no sound is heard from the headphones	Check headphones with another device. If headphones are good, then the most probable cause is a broken phone jack or damaged cabling internally. Return it to Radiodetection for repair
At high sensitivity levels, a continuous tone is heard and this tone ceases when the sensitivity is reduced.	The Locator electronics are breaking into oscillation. Make sure the headphones in use are the ones supplied and approved for use with the RD500
The Locator does not seem to have adequate location range and it fails the sensitivity test described above	Observe battery test at Power up and replace battery if required. Otherwise, return it to Radiodetection for repair.
Control Housing or other plastic parts have become loose or disconnected	Return to Radiodetection for repair

3.3 Locator Cleaning, Inspection and Repair:

Use a soft sponge in a mild solution of soap and water to clean the exterior of the Locator assembly. Make sure the battery compartment is closed while cleaning the Locator and open it up to dry afterwards.

Inspect the following items and make any necessary repairs as directed below:

1. Examine the handle grip and make sure that it touches the lower edge of the control housing when it is closed. If the handle has slipped down, wet it thoroughly with a wet sponge and extend its length until it touches the coupling directly below it and the edge of the control housing above it. Let the handle dry in this position. Installation of a new handle grip requires removal of the control housing from the lower pole assembly and a special tool to enable the handle grip to be installed over the battery housing. The Locator must be returned to Radiodetection for this repair.
2. Check all of the mechanical joints used to form the Locator case and make sure that they are not loose or separated. **CAUTION: If the lower cap becomes cracked, loose or separated from the pole, then the complete Locator must be returned to Radiodetection for repair. This end of the pole contains the sensor, which is potted inside the pole and special techniques are required to repair the assembly.**
3. Examine the ON/ OFF Sensitivity knob to make sure that it is attached tightly to the shaft and the two Allen head screws are both tight. Use a 0.05 inch Allen Wrench.
4. Check to make sure the headphone jack is tight in the control housing and gently tightened as required.
5. Look at the BATTERY Compartment Change Button and make sure it is not loose in the control housing. If it is loose, tighten the two mounting screws.
6. Check the black plastic rivet located directly below the "MADE IN USA" decal and make sure that it is held down firmly against the surface of the control housing. If it can be pulled out, it must be returned to Radiodetection for repair.

If you have problems that require further assistance, please call your local Radiodetection Sales Office or use our Customer Support Portal <http://support.radiodetection.com>

RD500 THEORY

1.0 Vibration:

Vibration is applied at a single point and attenuates rapidly as the soil absorbs the movement.

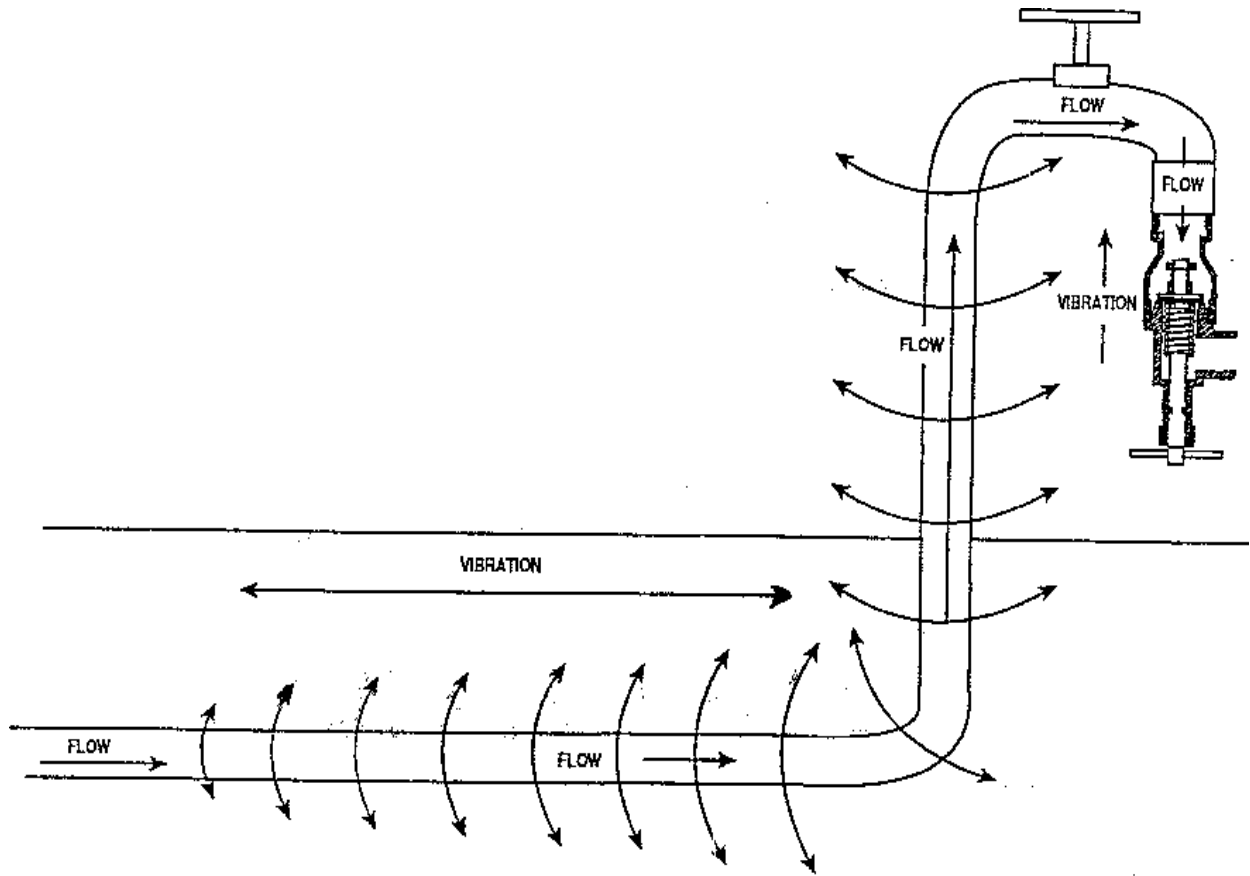

2.0 Stage 1: Water Flowing

- ✓ Water Flows
- ✓ Velocity increases as it passes through narrow valve aperture
- ✓ Pressure to close the Pulse Transmitter builds
- ✓ Pressure behind Pulse Transmitter "T" seat reduces
- ✓ Pressure builds to a point at which it closes the Pulse Transmitter
- ✓ Flow stops

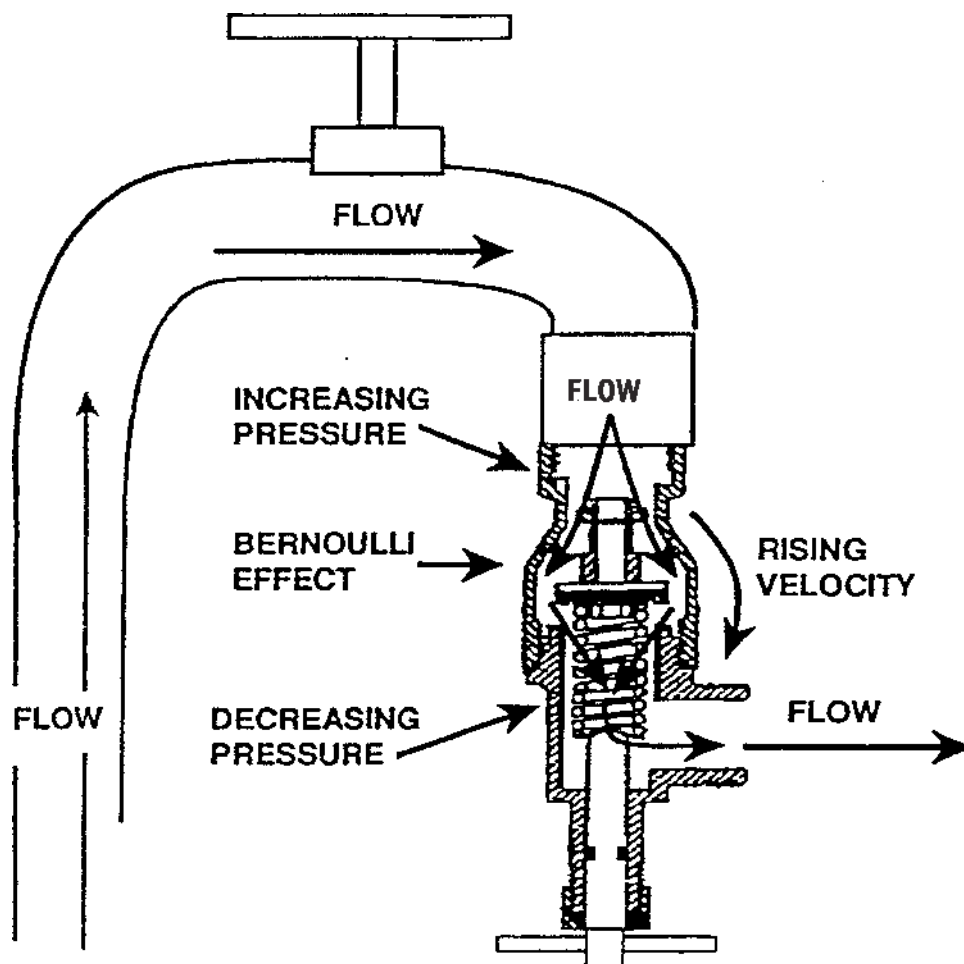

3.0 Stage 2: Pressure Wave Created

- ✓ Pulse Transmitter is closed
- ✓ Flow ceases
- ✓ Pressure continues to build
- ✓ Pressure has nowhere to go and returns in the form of a pressure wave back along the pipe

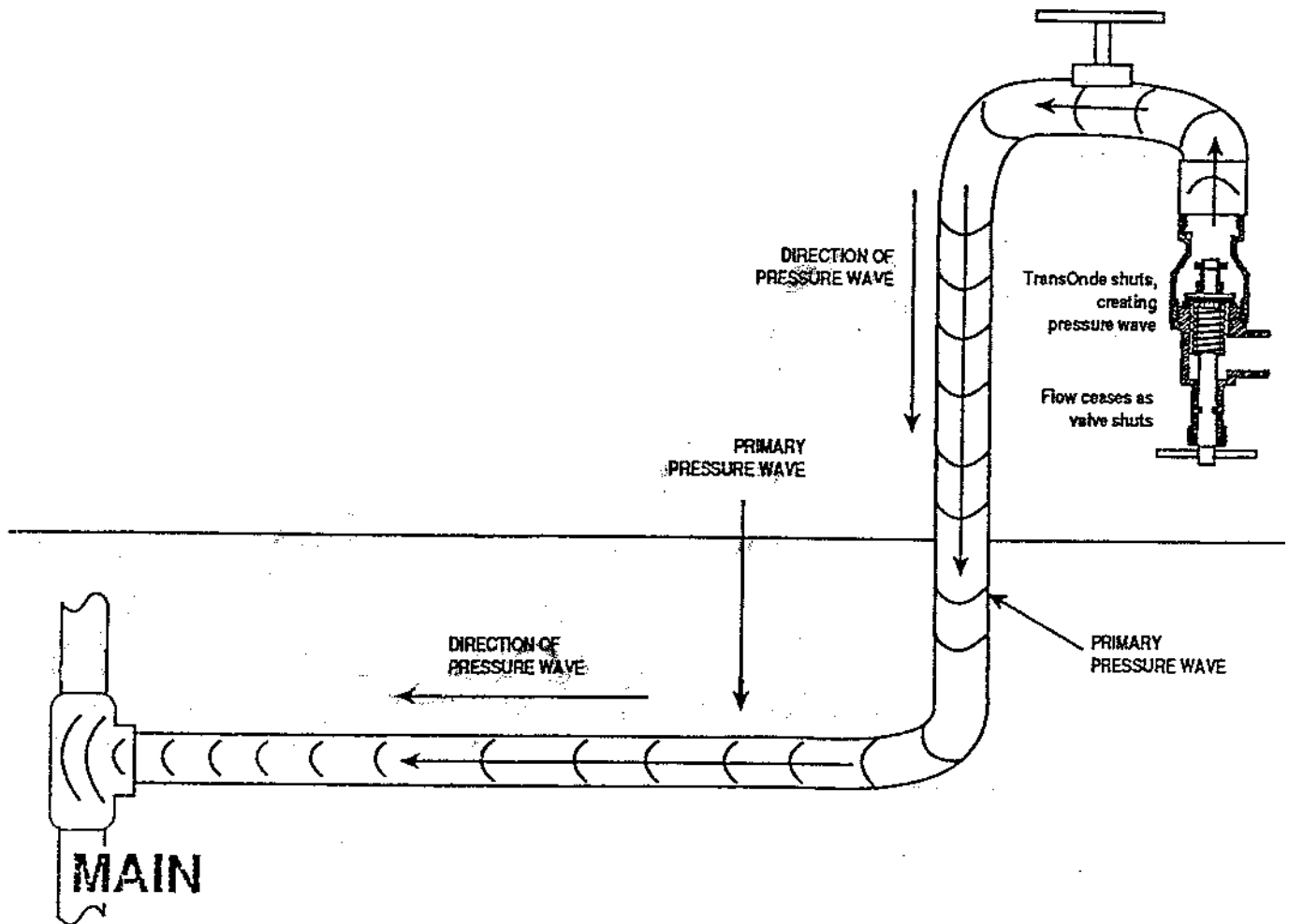

4.0 Stage 3: Pressure Wave Is Reflected

- ✓ The pressure wave meets the reservoir (main)
- ✓ The pressure wave continues at reduced intensity in both directions along the run
- ✓ Some of the pressure wave reflects back towards the Pulse Transmitter

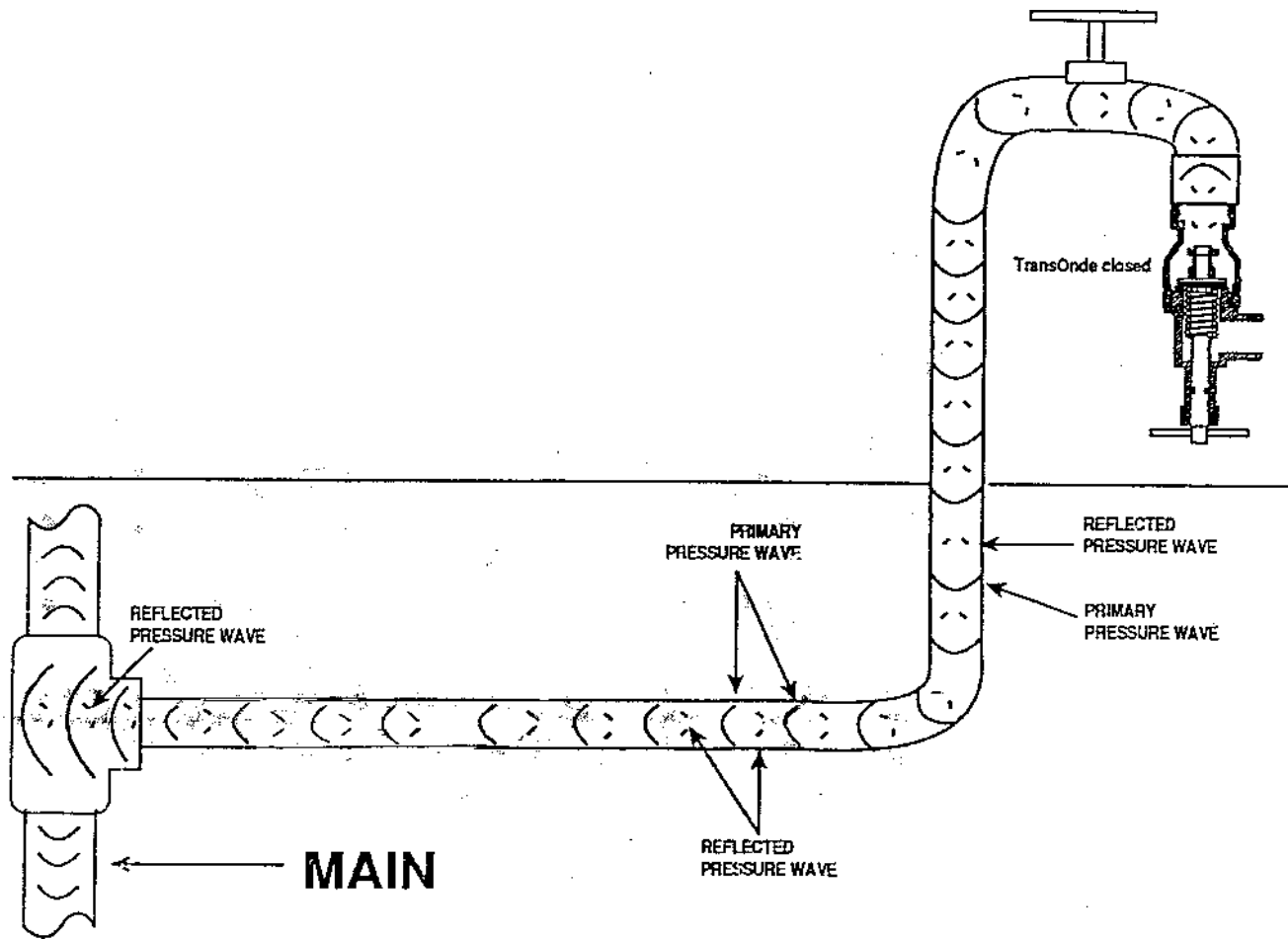

5.0 Stage 4: Pulse Transmitter Flow is Re-established

- ✓ As a result of the T-Seat being closed, the flow ceases
- ✓ The pressure wave creates a trough of reduced pressure in its wake
- ✓ Combination of first two steps allows the spring to reopen the Pulse Transmitter
- ✓ Flow resumes
- ✓ Cycle restarts immediately as water flows again.

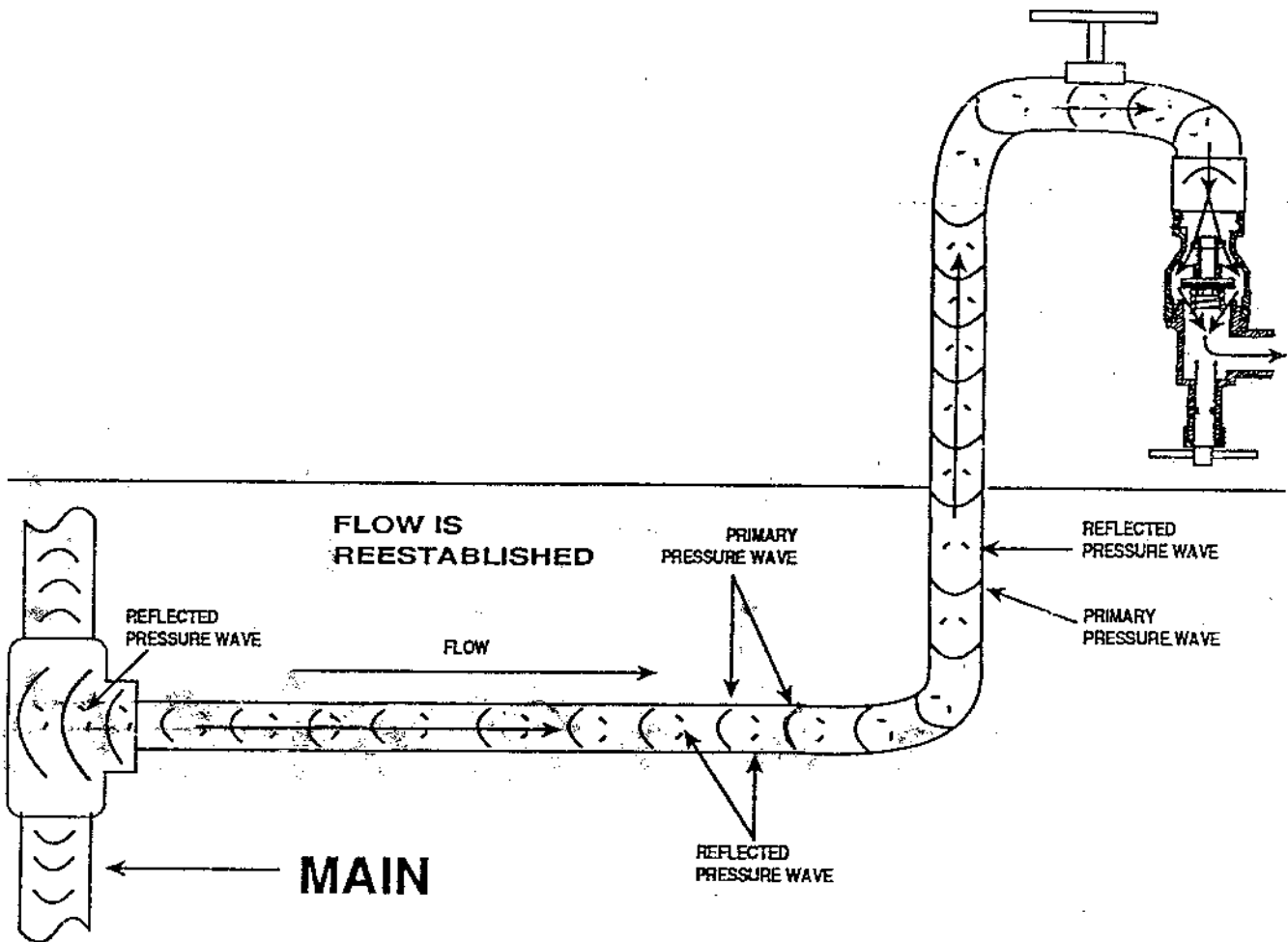

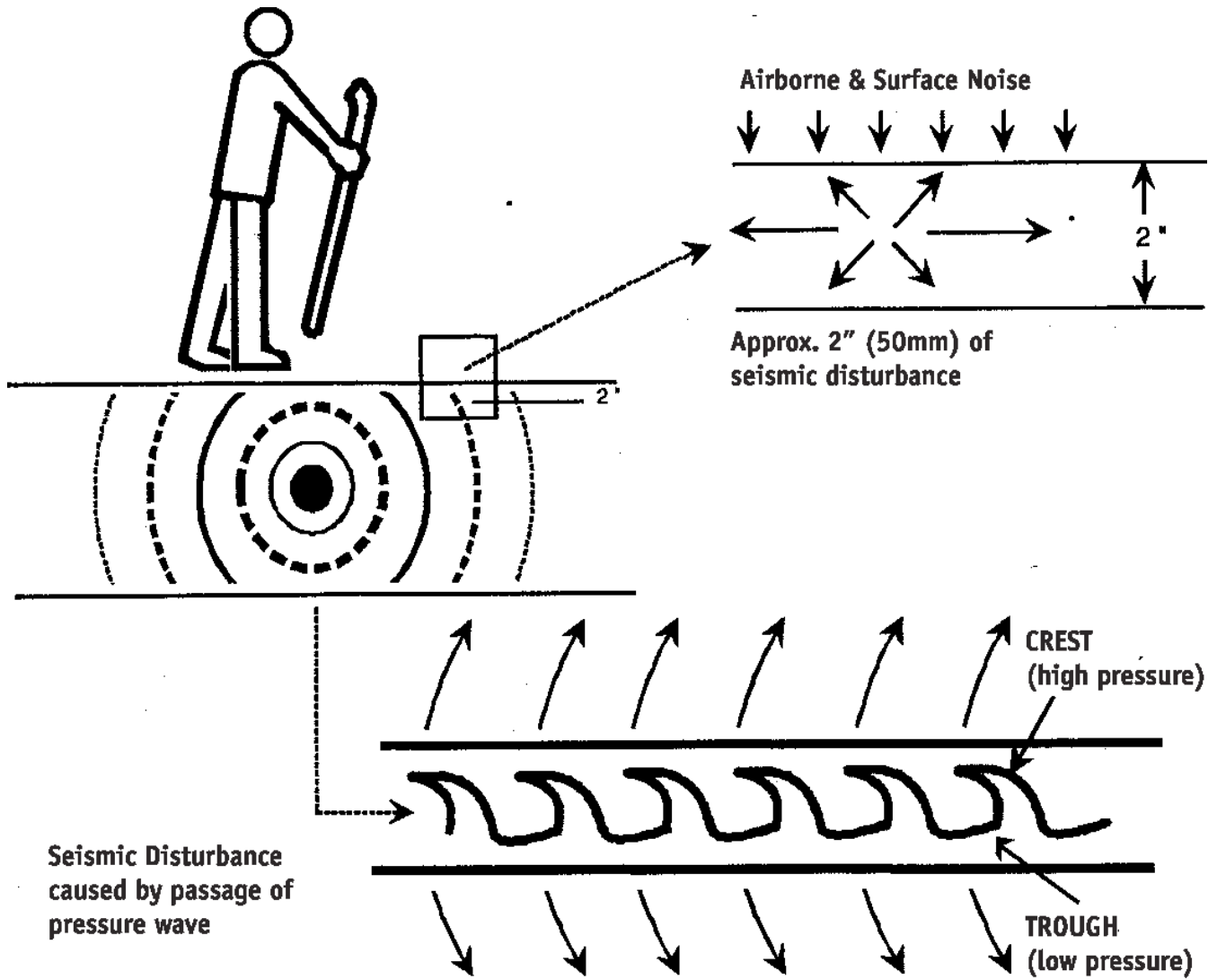

7.0 RD8100 Response vs. RD500 Response

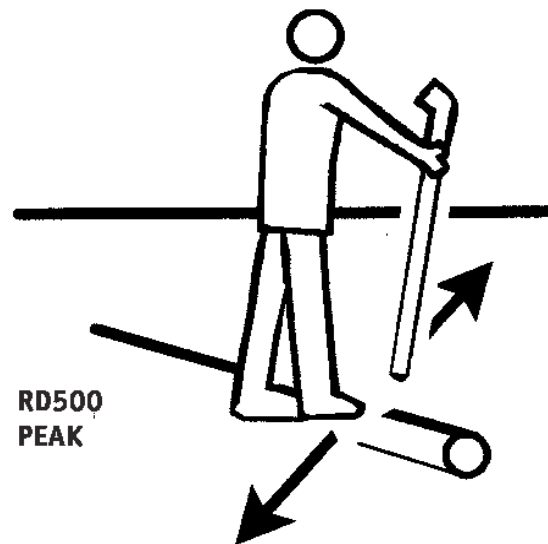
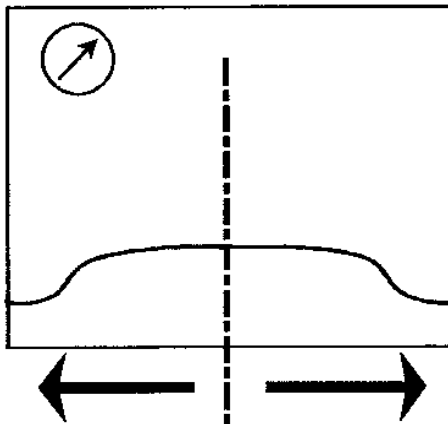
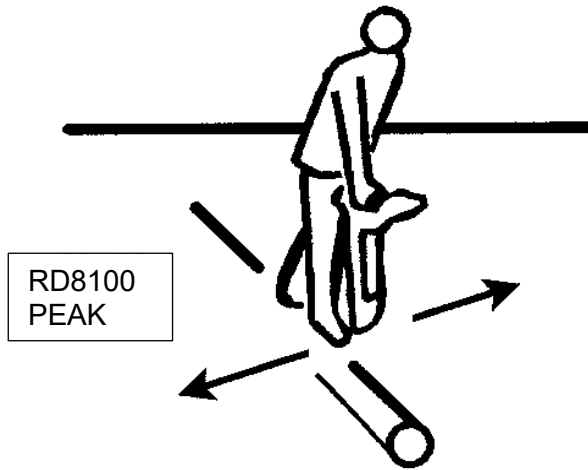
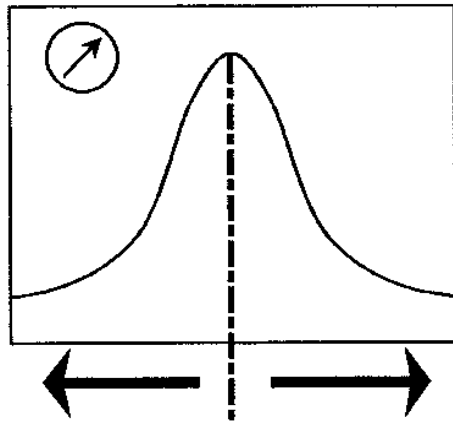
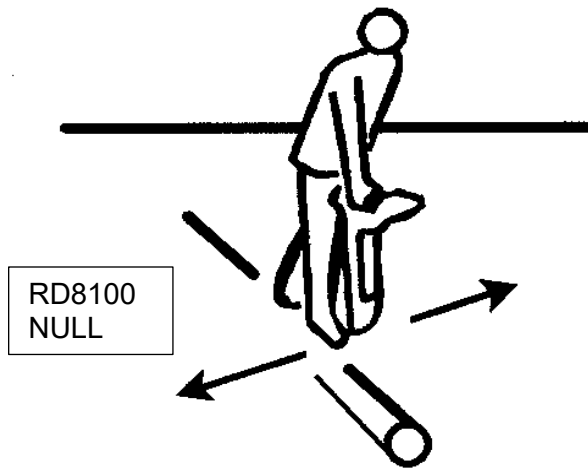
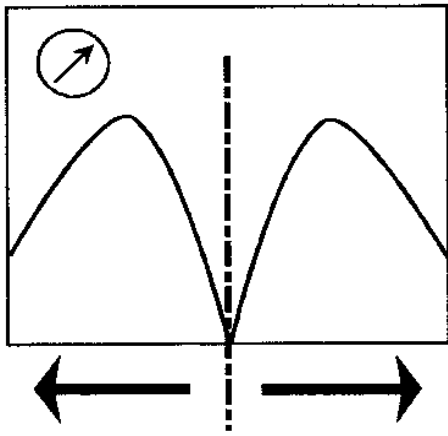

8.0 RD500 Operating Parameters

The RD500 will locate plastic/concrete transit non-metallic pipe, provided:

- Access point to water column is within 100-150 metres of target site (sometimes more)
- Correct adaption is available to fit Pulse Transmitter to water column
- Standing water pressure of 20 psi(g) – 150 psi(g) is available with flow of (5-10 litres) per minute
- Water pressure is reasonably stable
- Pipe system is in relatively good condition
- Pipe is less than 205cm deep
- No 'in-line" pressure regulator
- Soil/ ground conditions do not include strata of seismically absorbent material (i.e., soft sand, saturated "bog-type" soil, hardpan).
- Spike can penetrate beyond the 50mm surface vibration zone.

9.0 Expectations

There are crucial differences between using a "Precision" Radiodetection locator and the RD500. There are also some important similarities.

SIGNAL APPLICATION

Differences:

1. Messy to apply signal (mud, water flowing, etc.)
2. Mechanical hardware
3. Hysteresis in value
4. Takes longer to produce an acceptable signal

Similarities:

5. Time spent carefully applying the signal is crucial to a good locate
6. Pre-trace investigations (using visual clues and customer knowledge help to obtain a successful locate

TRACING & PINPOINTING

Differences:

1. Much flatter peak locate
2. Less precise pinpoint. Generally, the peak extends 15cm either side of the pipe
3. Your movement and grip on the Locator (plus local movement) may register on the Locator
4. No bleed-off to adjacent services
5. 50/ 60Hz interference will not influence locate
6. Performance is reduced under concrete or tarmac

Similarities:

1. The lower the frequency (of pulse), the farther the tracing distance
2. Position of Locator is important
3. Locate to the edge of the peak (both sides) to ensure a correct locate
4. Starting the trace from the Pulse Transmitter (Pulse Transmitter) and working away makes the locate easier

GENERAL POINTS

Distance:

The RD500 works for shorter distances - generally 150 metres and seldom more than 500 metres

Damage:

The Pulse Transmitter will not harm services that meet utility code (in USA, pipes are rated to 50% over local maximum pressure). HOWEVER, Pulse Transmitters will find weak points in plumbing systems and will aggravate existing leaks, always use a tap damper as supplied between the Pulse Transmitter and the water outlet.

Acceptance:

The RD500 is frequently appreciated more by the customer who is not as familiar with precision locators.

Copyright © 2020 Radiodetection Ltd. All rights reserved. Radiodetection is a subsidiary of SPX Corporation. Radiodetection is a trademark of Radiodetection Ltd. Due to a policy of continued development, we reserve the right to alter or amend any published specification without notice. This document may not be copied, reproduced, transmitted, modified or used, in whole or in part, without the prior written consent of Radiodetection Ltd. The RD500 is manufactured by Heitman Laboratories, Inc., Plano, Texas, USA and is protected by national patents.

Visit www.laserman.com.au

Global locations

Radiodetection (USA)

28 Tower Road, Raymond, Maine 04071, USA

Toll Free: +1 (877) 247 3797 Tel: +1 (207) 655 8525 rd.sales.us@spx.com

Schonstedt Instrument Company (USA)

100 Edmond Road, Kearneysville, WV 25430 USA

Toll Free: +1 888 367 7014 Tel: +1 304 724 4722 schonstedt.info@spx.com www.schonstedt.com

Radiodetection (Canada)

Unit 34, 34-344 Edgeley Blvd. Concord, Ontario, ON L4K 4B7, Canada

Toll Free: +1 (800) 665 7953 Tel: +1 (905) 660 9995 rd.sales.ca@spx.com

Radiodetection Ltd. (UK)

Western Drive, Bristol, BS14 0AF, UK

Tel: +44 (0) 117 976 7776 rd.sales.uk@spx.com

Radiodetection (France)

13 Grande Rue, 76220, Neuf Marché, France

Tel: +33 (0) 2 32 89 93 60 rd.sales.fr@spx.com

Radiodetection (Benelux)

Industriestraat 11, 7041 GD 's-Heerenberg, Netherlands

Tel: +31 (0) 314 66 47 00 rd.sales.nl@spx.com

Radiodetection (Germany)

Groendahlscher Weg 118, 46446 Emmerich am Rhein, Germany

Tel: +49 (0) 28 51 92 37 20 rd.sales.de@spx.com

Radiodetection (Asia-Pacific)

Room 708, CC Wu Building, 302-308 Hennessy Road, Wan Chai, Hong Kong SAR, China

Tel: +852 2110 8160 rd.sales.asiapacific@spx.com

Radiodetection (China)

13 Fuqiangyi Street, Minghao Building D304, Tianzhu Town, Shunyi District, Beijing 101312, China

Tel: +86 (0) 10 8146 3372 rd.service.cn@spx.com

Radiodetection (Australia)

Unit H1, 101 Rookwood Road, Yagoona NSW 2199, Australia

Tel: +61 (0) 2 9707 3222 rd.sales.au@spx.com



60 Knutsford Street Fremantle WA 6160

info@laserman.com.au | team@laserman.com.au ☎ 08 9335 1718

Copyright © 2020 Radiodetection Ltd. All rights reserved. Radiodetection is a subsidiary of SPX Corporation. Radiodetection is a trademark of Radiodetection Ltd. Due to a policy of continued development, we reserve the right to alter or amend any published specification without notice. This document may not be copied, reproduced, transmitted, modified or used, in whole or in part, without the prior written consent of Radiodetection Ltd. The RD500 is manufactured by Heitman Laboratories, Inc., Plano, Texas, USA and is protected by national patents.