



MOBA-MATIC & BIG SONIC-SKI

MOBA[®]
MOBILE AUTOMATION

HOW TO GET RID OF ROAD WAVES - A MAJOR PROBLEM WHEN RECONSTRUCTION OR RENOVATING ROADS

In road construction, particularly in road reconstruction and renovation, a major problem occurs after having milled the surface. Significant unevenness evokes road waves in large areas of the road, which increasingly impairs road quality. The solution, however, is a system that considers large sections of the ground to monitor bumpy passages and perfectly level them out, such as the unique combination of the two leveling systems MOBA-matic II and Big Sonic-Ski.

4 ultrasonic sensors enables you to sense nearly all surfaces, irrespective of their condition. Even irregularities within a ground section of up to 6 meters will be reliably smoothed. The more Sonic-Skis are integrated into the system, the more precise the leveling gets.

BIG SONIC-SKI
SMOOTHNESS
X-TENDED





**NEW ASPHALT
SURFACE WITH
PERFECT SMOOTHNESS**

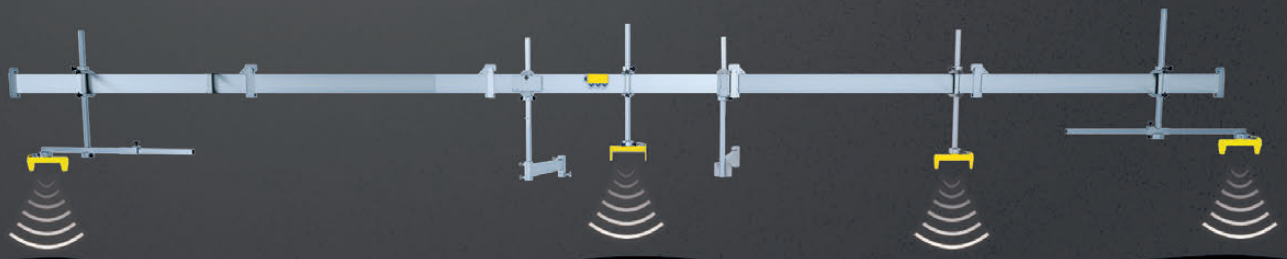

MOBA-MATIC - THE MOST VERSATILE CONTROL SYSTEM IN THE WORLD

SYSTEM - BENEFITS

- » Largest selection of sensors anywhere
- » Modular system allows multiple combinations
- » Easy to install
- » High-precision, dependable results
- » 3D-capable (GNSS and Total Station positioning solutions)
- » CAN communication technology
- » One system can be used on many machines



Thanks to the extreme modularity of the system you can flexibly combine a wide range of sensors to achieve optimum results for your specific project. The system always adapts perfectly to your personal needs and can be time- as well as cost-efficiently be adjusted or upgraded anytime! With the practical two-in-one control panel, which includes a controller as well as operating unit in one housing, operation is not only easy but also time-efficient.

For more than 30 years, the MOBA-matic thus has proven itself as the first choice in road construction when precision, usability and efficiency matter.

MOBA-MATIC II CONTROLLER THE “HEART” OF THE SYSTEM

GRADE SENSOR SONIC-SKI

- » Five ultrasonic contact-free sensors scan the reference surface
- » Extremely precise distance measurement by means of averaging
- » CAN-interface

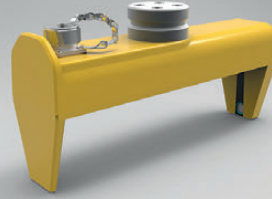

01

DIGI SLOPE SENSOR

- » Especially designed for high vibration screeds
- » Slope angle display available simultaneously with level information
- » Simple and easy to recalibratable



02

LACER RECEIVER LS-3000

- » Compatible with all common rotating laser transmitters for machine control
- » Digital linear detection of the laser beam
- » No electrical mast required for height adjustment
- » Reference point user selectable with a single button press



03

DIGI ROTARY SENSOR

- » Can be used under all climatic conditions
- » Operates in stringline and ground sensing modes



04

WIRE ROPE SENSOR

- » Very precise height position measurement for milling applications
- » The user can easily replace the steel wire (wearing part)
- » Measuring range: 500 mm

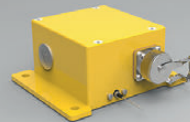

05

IR TEMPERATURE SENSOR

- » Measurement of material temperature
- » Installation in the hopper or behind the screed
- » Temperature information in real time at MOBA-matic II

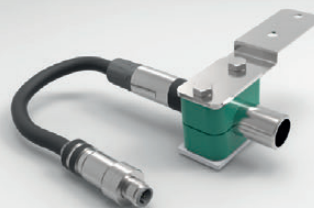

06

BIG SONIC-SKI - EASY MOUNTING FOR FASTER RESULTS

The Big Sonic-Ski is a unique 4-sensor solution on the paving market and guarantees extraordinary results in paving quality. Unevenness that fails to be detected by only three sensors are easily leveled out with the Big Sonic-Ski. Not only does it increase smoothness and road quality but also is it easily installable, user-friendly and extendable to up to 13 meters.

The flexible mounting and quickly adjustable positions of the four sensors additionally increase maneuverability of the paver and guarantee the perfect surface in curved roads. It is thus always perfectly equipped even in troublesome environments.

SYSTEM BENEFITS

- » High precision thanks to constant averaging of measurements of 4 independent sensors
- » Time saving due to user-friendly mounting and operation possibilities
- » Increased smoothness by monitoring large sections of the ground

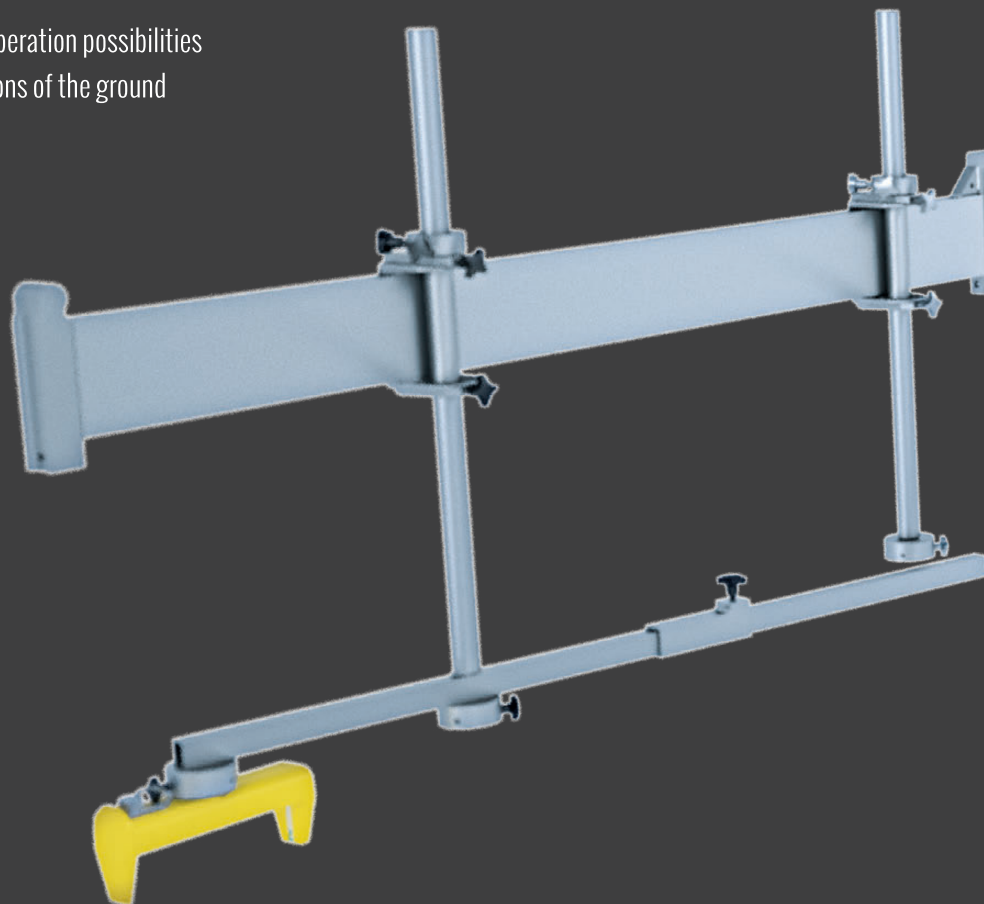

BIG SONIC-SKI - LONG-RANGE AVERAGING VIA

SKI1+SKI2+SKI3+SKI4

4

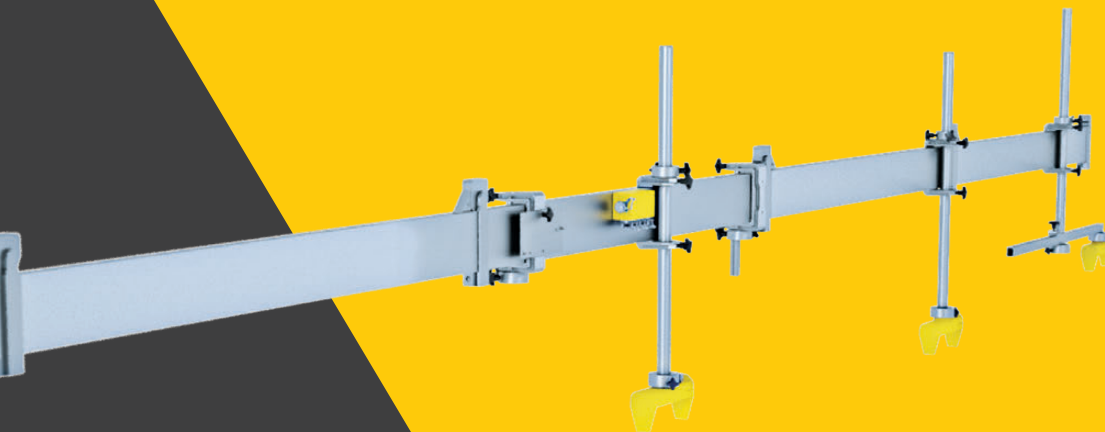
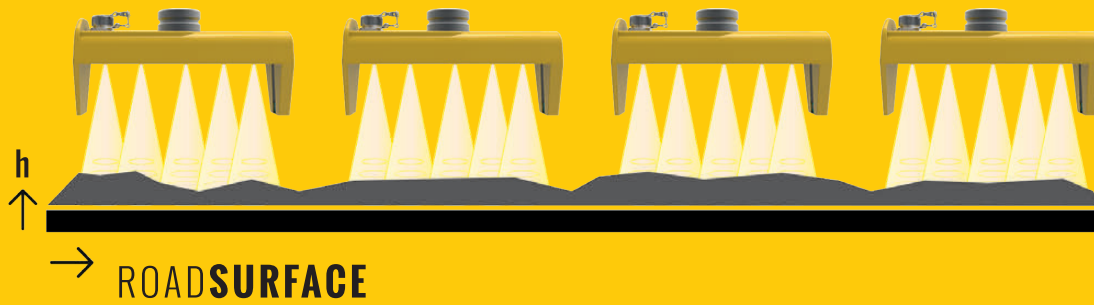

LONG-RANGE AVERAGING VIA

- » Combines the positive effects of four Sonic-Ski plus sensors
- » Multiple integrated scanning across the whole reference
- » Provides a long range continuous virtual level reference
- » Unevenness over longer stretches is also corrected

ONE GROUP - ONE RESPONSIBILITY



◆ HEADQUARTERS

● SUBSIDIARIES

● DEALERS

MOBA GROUP

The **MOBA GROUP** is a leading global player in the world of mobile automation. Close collaborations between the headquarter in Limburg an der Lahn and subsidiaries all over Europe, Asia, North and South America create new perspectives for recent and future developments.

Superior technical knowhow and more than 40 years of experience combined with an international dealer network guarantee a premium support - **worldwide. INSPIRING MOBILE AUTOMATION** - this is what the **MOBA GROUP** stands for.

MOBA GERMANY

65555 Limburg / Deutschland
Tel.: +49 6431 9577-0
E-Mail: sales@moba.de

MOBA ITALY

37069 Villafranca die Verona / Italien
Tel.: +39 045 630-0761
E-Mail: mobaitalia@moba.it

MOBA FRANCE

77164 Ferrières en Brie
Tel.: +33 (0) 1 64 26 61 90
E-Mail: infos@mobafrance.com

MOBA UK

HP178LJ Haddanham / Great Britain
Tel.: +44 184 429 3220
E-Mail: ilewis@moba.de

MOBA SPAIN

08211 Barcelona / Spain
Tel.: +34 93 715 87 93
E-Mail: moba-ise@moba-ise.com

MOBA USA

Fayetteville GA 30214 / USA
Phone: +1 678 8179646
E-mail: mobacorp@moba.de

MOBA BRASIL

Belo Horizonte - MG / Brasil
Phone: +55 31 7513-4959
E-mail: mobadobrasil@moba.de

NOVATRON FINLAND

33960 Pirkkala / Finland
Phone: +358 (0) 3 357 26 00
E-mail: sales@novatron.fi

NOVATRON SWEDEN

192 79 Sollentuna / Sweden
Phone: +46 (0) 8 660 52 00
E-mail: sverige@novatron.eu

MOBA INDIA

Gujarat - 382044 / India
Tel.: +91 989 855 6608
E-Mail: sdesai@moba.de

MOBA CHINA

116600 Dalian / China
Phone: +86 411 39269311
E-mail: ysun@moba.de

www.moba-automation.com
www.mobacommunity.de

MOBA[®]
MOBILE AUTOMATION