

# 830 Laser Alignment Tool

Quick Reference Guide

### Warning

To prevent possible electrical shock, fire, or personal injury, read the "830 Safety Sheet" before you use this Product.

Go to [www.fluke.com](http://www.fluke.com) to register your product, download manuals, and find more information.

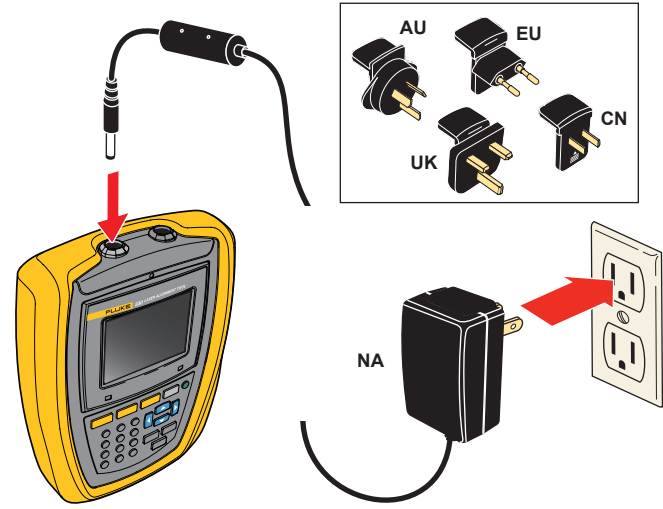

## Preparation

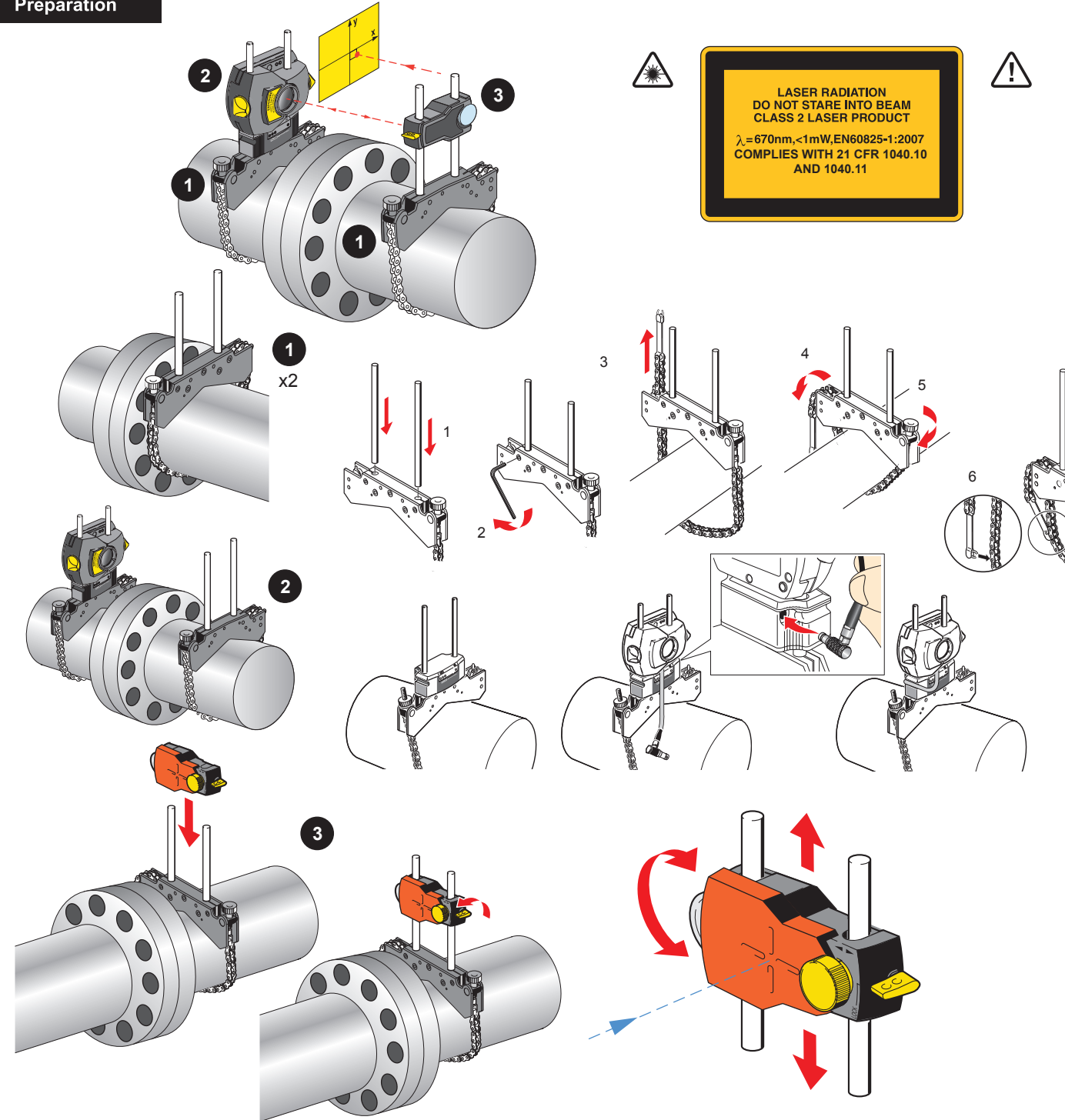

## Step 1 Setup: Enter Machine Dimensions

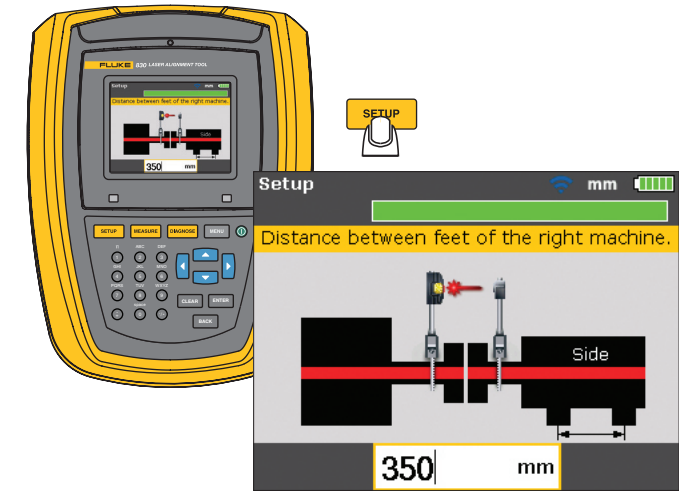

### 1 Take dimensions

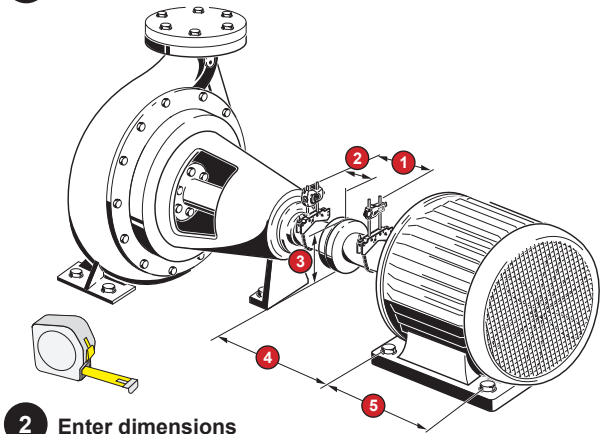

### 2 Enter dimensions

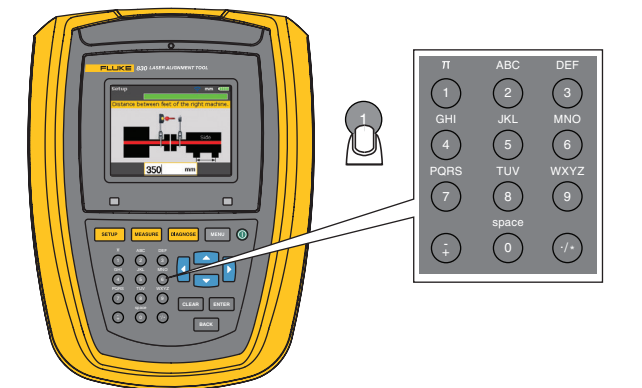

## Overview of 830



## Step 2 Measure: Take 3 Readings

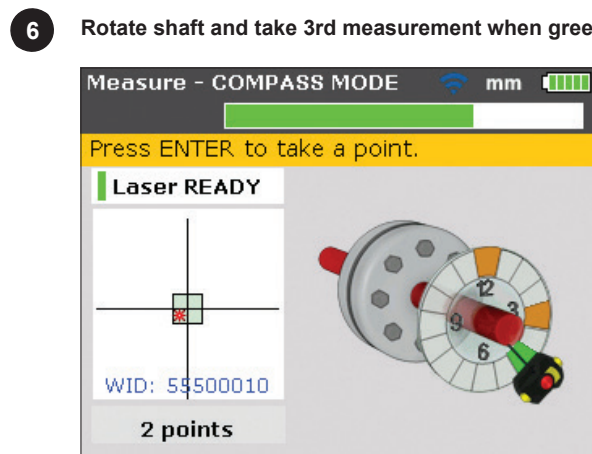
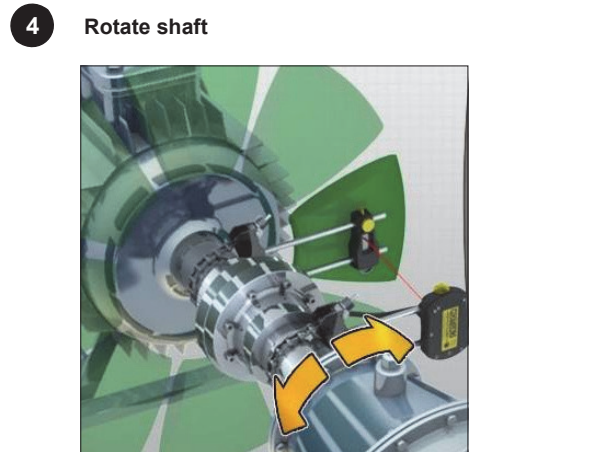
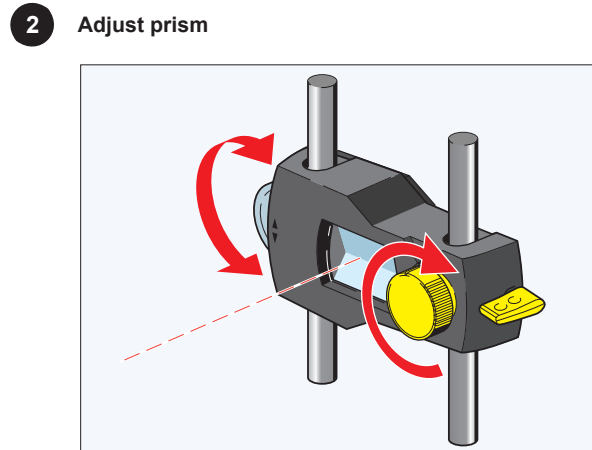
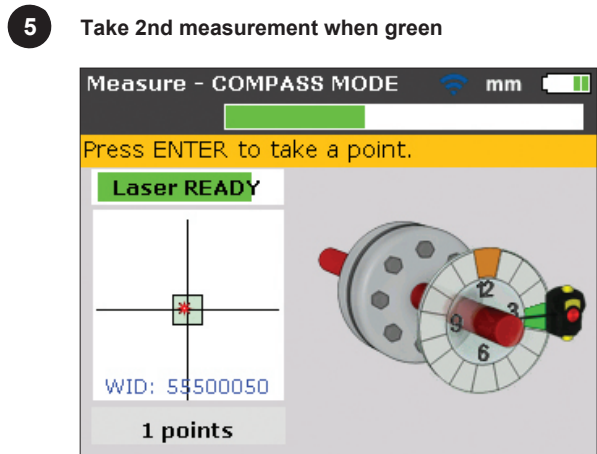
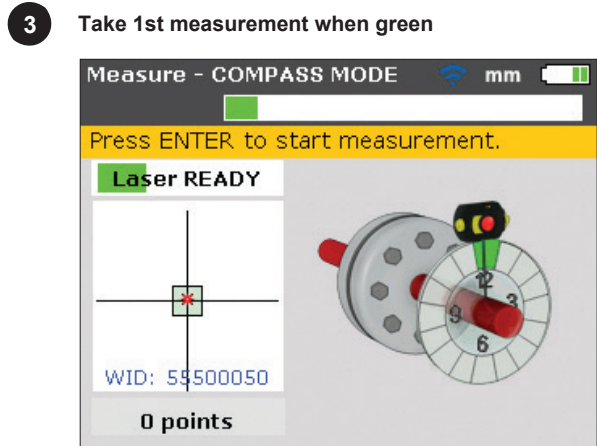
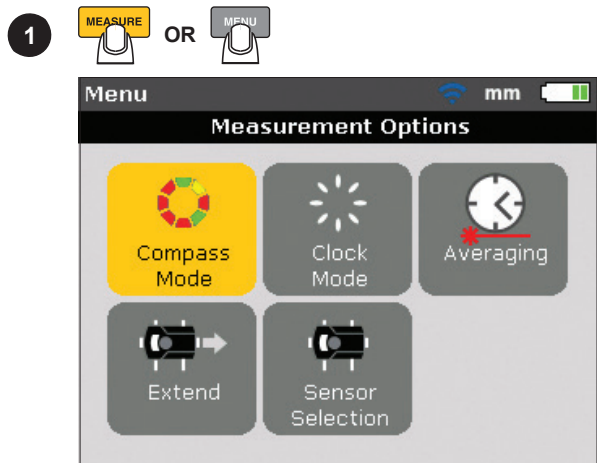

## Step 3 Diagnose: Make Foot Correction

1 **Diagnose**

Vertical	Side
Gap -0.04	-0.02 -0.15
Offset -0.05	
Horizontal	Top
Gap +0.22	+0.29 +0.98
Offset +0.08	

**Alignment condition**

Tolerance	Tolerance Bar	LED Color
Excellent Tolerance		Green
Acceptable Tolerance		Yellow
Out-of-Tolerance		Orange
Grossly Misaligned		Red

**Adjustment needed**

2A

2B

**Alignment values**

A

B

C

D

2A

2B

## Final Check

1 **Move**  
Angle ok, please wait or press ENTER to continue.  
Move sensor to a green position.

2 **Move**  
Press ENTER to select move direction.  
Laser READY  
Choose Move orientation  
Horizontal Vertical

3 **Move - Horizontal**  
Move in progress, press ENTER to stop.  
Static Movable  
Horizontal 0.17  
Gap -0.04 +0.32 +0.71

4 **Move - Horizontal**  
Press ENTER to choose an option.  
Laser READY  
Move Options  
Stop and Measure Re-enter Move Extend  
Offset -0.01 -0.20 -0.44

5 **Menu**  
Main menu  
Left Machine Coupling Tol. Right Machine Move Soft Foot  
File Measure Options Print Report Config Turn Off

## Optional Check: Soft Foot

1 **Menu**  
Main menu  
Left Machine Coupling Tol. Right Machine Move Soft Foot  
File Measure Options Print Report Config Turn Off

2 **Soft Foot**  
Press ENTER to measure indicated foot.  
Laser READY

3 **Soft Foot**  
Loosen the bolt and press ENTER to measure soft foot reading.  
Laser READY  
-0.00

4 **Soft Foot**  
Press ENTER to measure indicated foot.  
Foot measurement now finished. Please retighten the bolt and measure another foot.  
Laser READY  
+0.04

5 **Soft Foot**  
Press ENTER to display soft foot tolerances.  
Soft foot has been detected.  
Laser READY  
+0.07 +0.02