

# STERIL-AIRE®

UVC for HVAC™

## SteriLight II™ Model RSE II Series UVC Emitters™

Very High Output  
Germicidal Light Source  
for Residential Systems

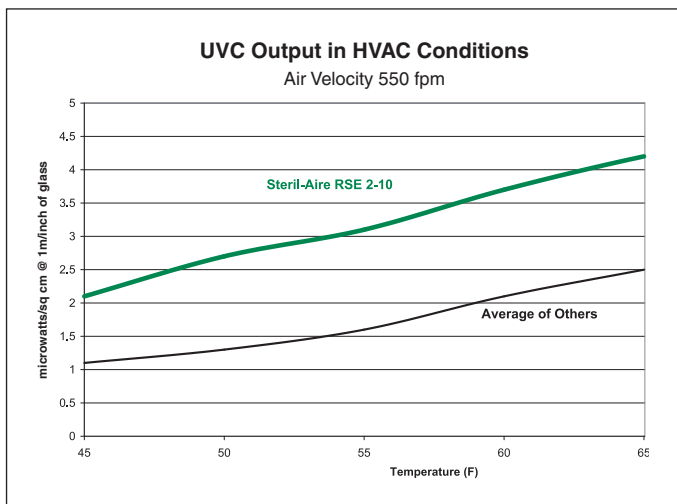

Steri-Aire's multi-patented UVC Emitter™ provides the best and longest-lasting UVC performance available. As shown in the comparison graph (above), it has been independently tested to deliver an average of 5 times the output of other ultraviolet devices under HVAC operating conditions (45° F @ 550 fpm air velocity).

Competitive UVC lights must be changed every 3-4 months because they quickly lose the output or "killing power" needed to maintain microbial control. The UVC Emitter, by contrast, has a 12-month service life – and even after a full

year, it has 2-1/2 times greater output than competitive devices deliver on Day 1! As a result, only Steril-Aire can ensure the germicidal performance you need, with no return of microbial growth, for 3-4 times longer than the competition.

### Applications

SteriLight Model RSE II fixtures are designed for residential and light commercial applications, including conventional "A" style coils, slabs and slants up to 5 tons. The double-tube device installs quickly and easily from outside the coil box by making two one-inch holes in the box, attaching the fixture with self-tapping screws, and wiring as required (soft or hard wired). Only the lamps or tubes penetrate into the system, while the power supply remains external. Choose from three tube lengths (16", 20" and 24"), configurations of 10" or 14" centerlines, and three voltage options (115, 208 or 230 Vac).

### Benefits

- Kills or inactivates surface and airborne microorganisms that contribute to poor IAQ and/or the spread of infectious disease, including: mold and mold spores, bacteria (including *TB*, *Legionella*, *E. coli*, *Listeria*, *salmonella* and *whooping cough*); and viruses (including *colds*, *flu*, *measles*).
- Delivers an average of 5 times the output of competitive UVC products at HVAC operating temperatures, for 3-4 times longer life and more reliable germicidal control.
- Uses patented state-of-the-art solid-state electronic power supply for enhanced reliability and performance.
- Continuously cleans coils, drain pans, plenums and ducts, eliminating costly cleaning programs and the use of harmful chemicals and disinfectants.
- Lowers A/C energy costs by restoring heat transfer and net cooling capacity.
- Produces no ozone or other secondary contaminants – will not harm occupants, furnishings or A/C equipment.
- Offers lowest life-cycle cost of any UVC product. Return on investment is often less than one year.
- Installs quickly and easily, with no need to open equipment.

# Model RSE II Specifications

**All SteriLight II™** units shall be factory assembled and tested. They shall consist of a housing, power supply, Emitter sockets and two Emitters.

**The housing** shall be constructed of galvanized steel to withstand HVAC environments and shall be equipped with a 1/2" electrical conduit opening to facilitate wiring. All components shall be incorporated into one integral assembly that maximizes serviceability. It shall be designed for mounting from outside the airstream with only the Emitters in the conditioned air. The Emitters shall be held in place and supported in the airstream by a patented integral collar, o-ring

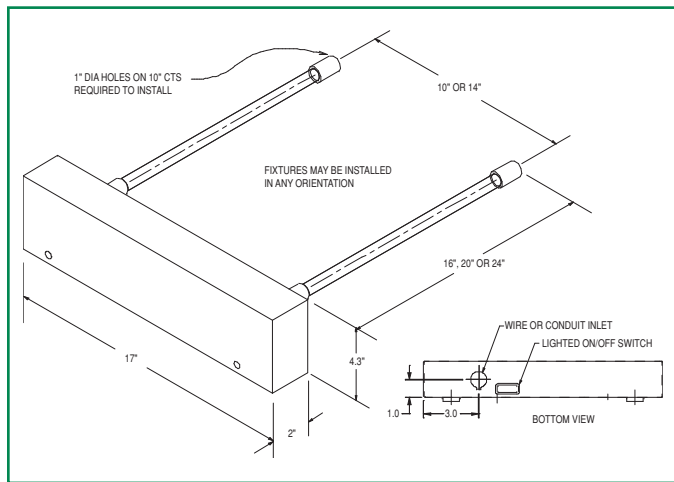

*This product may be covered by one or more of the following patents, others pending: 5,334,347/ 5,866,076/ 5,817,276/ 6,372,186/ 6,313,470/ 6,245,293/ 6,267,924/ 6,280,686/ 6,423,882.*

and heavy-duty fastener. The housing shall include an on-off switch and an indicator light to verify that the Emitters are functioning.

**The power source** shall be a Class P2, electronic rapid start type with a power factor of >0.95 and a power conversion of >75%. It shall be available in 115 or 208/230 Vac, 50/60 Hertz, and single phase. It shall be designed to maximize photon production, irradiance and reliability in cold or moving airstreams of 35-170° F, 100% RH and up to 2000 fpm. The design shall include RF and EMI suppression.

**The sockets** shall be a Circline® 4-pin type with sufficient wire length for ease of service.

**The Emitters** shall be a high output, hot cathode, T5 diameter, Circline® cell-base that produces a UVC band of 250-260 nm. Each tube shall be capable of producing the specified output at up to 2000 fpm velocity and temperatures of 35-170° F. It shall produce no ozone or other secondary contaminants.

**Independent testing:** The unit shall be tested by an independent test laboratory in accordance with the general provisions of IES Lighting Handbook, 1981 Applications Volume, and shall be verified through independent testing to provide output per 1" arc length of not less than 10 µW/cm<sup>2</sup> at 1 meter in a 400 fpm airstream of 45° F.

Unit shall comply with UL Standard 1995 for use in HVAC equipment and shall carry the "UL" and "ULC" labels.

## Ordering Information

Model No.	Part No.	Description	Length	Electrical	Weight
RSE 2-10 HO	40000700	Single-Ended Fixture	N/A	115, 208, 230V: 75 watts	3.0 lb.
RSE 2-14 HO	41000700	Single-Ended Fixture	N/A	115, 208, 230V: 75 watts	4.0 lb.
RGTS 16 HO	22000300	UVC Emitter	16"	N/A	0.15 lb.
RGTS 20 HO	22000100	UVC Emitter	20"	N/A	0.15 lb.
RGTS 24 HO	22000200	UVC Emitter	24"	N/A	0.20 lb.

# STERIL-AIRE®

**Steril-Aire, Inc.**

**Corporate Office:**

2840 N. Lima Street  
 Burbank, CA 91504  
 Telephone: 818.565.1128  
 Fax: 818.565.1129

Website: [www.steril-aire.com](http://www.steril-aire.com)  
 Email: [sales@steril-aire.com](mailto:sales@steril-aire.com)



Complies with current U.S. and Canadian UL Standards for use in HVAC equipment.

Represented By: