

Seam Ripper Kit

Kit Features

- Style A - Single Blade, small ripper with clip. Reverses into handle for safety.
- Style B - Double Blade, small & large rippers.
- Style C single small blade w/ magnetic necklace chain catch.
- Sharp blade reverses into handle for safety.
- 8mm tubes

Required Accessories

- 7mm, Pen Mandrel
- 8mm Drill Bit
- 8mm Barrel Trimmer
- 3 pc. Bushings Set # 3434 (use 2 of the 3 in the set for each style)
- 2 part glue, epoxy or Insta-cure (cyanoacrylate).

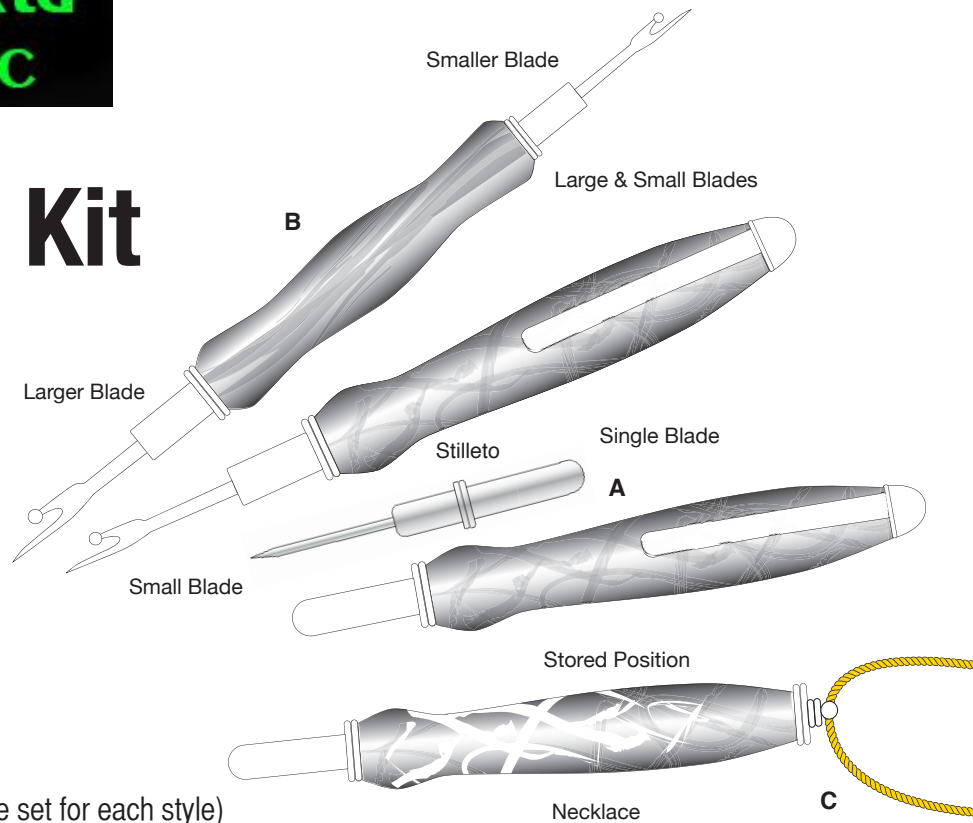
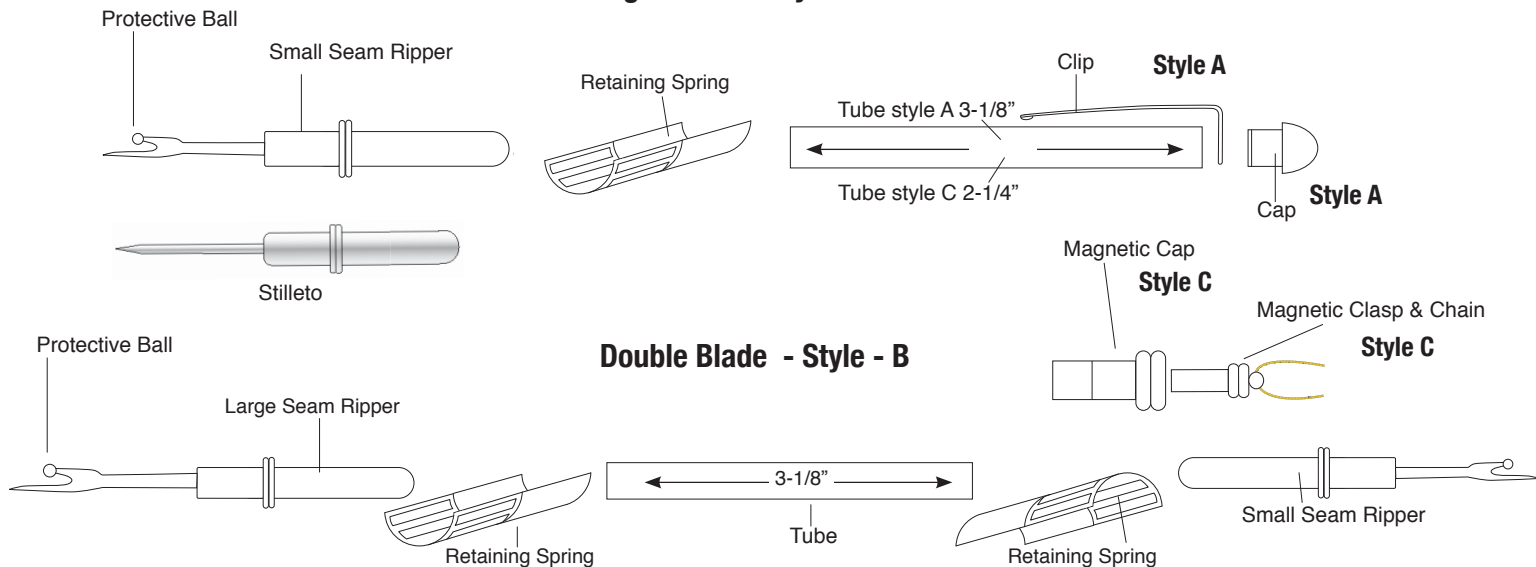

Diagram A - Parts List

Single Blade - Style - A & C



Preparing the Blank

- Prepare and cut a blank of 3/4" or larger, to the length of the brass tube (add 1/16" for trimming)
- Drill a 8mm hole through the center of the blank.
- Spread glue over the tube, insert into blank with a twisting motion to spread the glue evenly inside.
- Center the tube inside the blank.
- When glue is dry. Trim the ends of the blank flush to the tube.

Diagram B - Turning the Blank

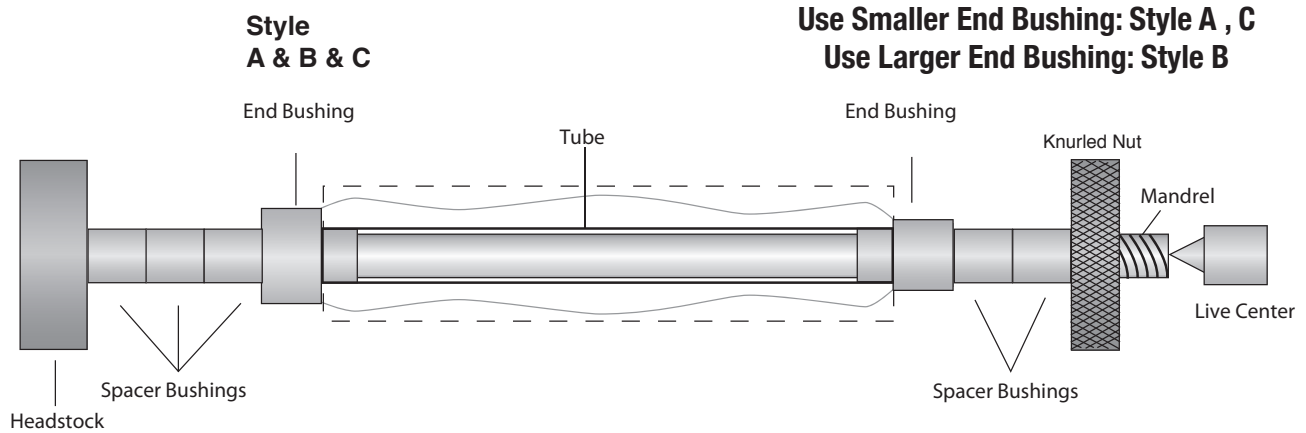

Turning the Blank

- Place the bushings and blank on the mandrel according to Diagram B.
- Use the larger end bushing on style A and a smaller bushing on the other end. For style B & C use the larger bushing on both ends.
- Thread on the knurled nut and hand tighten to hold all items in place.
- Slide the tailstock to the mandrel shaft, (do not overtighten, it could damage the mandrel) lock in place.
- Turn the handle ends down, flush with the bushings using the lathe tools, gradually increasing the grades of sand paper.
- Finish the wood with friction polish or use any PSI project finish of your choice.

Assembly

For Single style A & C:

- Place the clip over the extension of the cap. Press this assembly into the upper end of the handle with smaller diameter.
- Or (for necklace Style C) Press the magnetic cap, narrow end in first into the upper end of the barrel.

For Styles A, B & C:

- Squeeze the retaining spring to a small round circle (DO NOT CREASE) and insert into opening at the end(s). Push in, flush to the surface.
- Slide the seam ripper assembly in and out with both ends to assure a secure fit.
- If spring does not hold in properly (i.e. the spring slides into the tube), Take a Q-tip and dip into CA glue insert the spring and allow the CA to dry. The spring should now operate properly.
- When not in use, reverse the ripper assembly to safely store the blade(s).
- Insert the chain through the small ring on the magnetic bar, lock the clasp.
- Insert the bar into the magnetic cap.

Diagram E - Bushing # 3434

