

# CAPTUREPRO™

FOR TESLA MODEL S, MODEL X, AND MODEL 3

## USER GUIDE

---



Updated: September 2018

# Table of Contents

<b>CapturePro Purpose and Design</b> .....	3
Why was CapturePro developed? .....	3
How does it work? .....	3
What chargers would this work with? .....	3
<b>Instructions - Using CapturePro</b> .....	4
Starting a charging session with CapturePro .....	4
Ending your charging session when using CapturePro .....	5
Charge Port Unlocking .....	5
Removal of Charging Hardware .....	5
Emergency removal .....	5
<b>Product Details</b> .....	5
Label System .....	6
Suggested Use Model .....	6
Applying the Label System .....	7
<b>FAQ</b> .....	8

# CapturePro™ Purpose and Design

## Why was CapturePro developed?

We've heard stories of Electric Vehicles (EVs) being unplugged from public chargers by someone other than the owner – whether it's another EV user removing your charging station cables for their own use, or simple mischief, it seemed wrong that you can't lock your charging connection at public chargers in the same way the standard Tesla charging wand can (UMC or HPC). In certain situations being unplugged without your knowledge could inconvenience and even strand you.

CapturePro solves the problem of being unplugged without your consent at public charging stations by **locking your J1772 Tesla Charging Converter**. It's safe, fast, and easy to use.

Note that the CapturePro does not work with the original Tesla Roadster.

## How does it work?

CapturePro fits between your *Tesla's J1772 charging adapter* and the public charging handle - it locks everything together when your car locks, keeping your charging session secure.

There's more detail of how to install and use the CapturePro in the **Instructions** section, but here's a summary: During public charging the Tesla J1772 adapter connects the J1772 charging handle into your Tesla charge port – but, though the charging adapter is locked to the car, *the charging handle is not locked to the adapter*.

The CapturePro fits over the charging adapter and 'captures' the handle to the adapter. *As long as the Tesla J1772 charging adapter is locked to the car, the charging handle is locked to the adapter*.

Read *Instructions* section for more information.

## What chargers does CapturePro work with?

CapturePro fits all [J1772 Level 2 chargers](#) – these include **public infrastructure charging station** networks from ChargePoint, Blink, eVgo, etc. and private stations from various manufacturers.

CapturePro uses a series of slots that slide over the attachment hook on the J1772 connector – but, because each manufacturer of J1772 connectors uses a slightly different attachment hook size, the CapturePro lock must include a variety of slots sizes.

Read more on this in the Instructions Section, below

**Please alert Power12 if a charger is found which does not fit.**

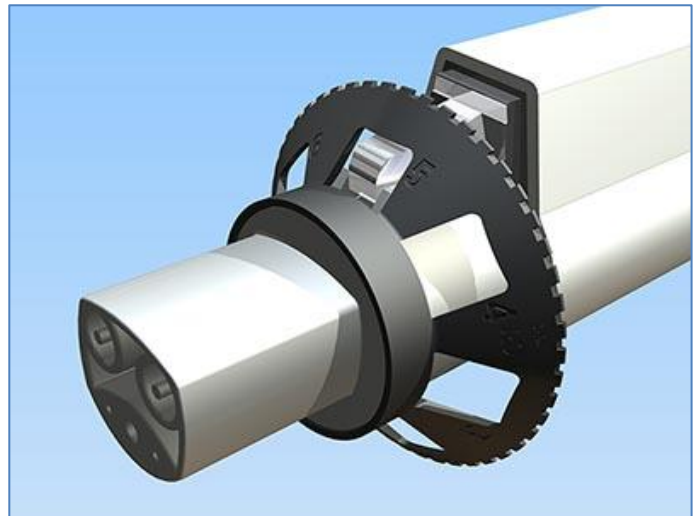

***The CapturePro carries a lifetime warranty against manufacturing defects. Also, In the unlikely case of damage or attack, or if you ever have to forcibly remove the unit yourself, contact your retailer or Power12 for a free replacement unit (pay only shipping).***

Contact Power12 at: [support@power12.com](mailto:support@power12.com)

## Instructions for using CapturePro

CapturePro charging lock protects your electric car charging session from disconnection until you unlock it – it's compact and easy to store with your Tesla J1772 charging adapter. It works with Model S, X and 3.

The following sections outline how to attach the CapturePro, and also how to remove it. Please fully review the Tesla J1772 Charging Adapter instructions before continuing with this document or using CapturePro.

### Starting a charging session with CapturePro

Before starting, use the Control Panel to unlock the charging port door, and make sure the J1772 charging station is enabled with your access card, so that charging is ready to begin.

**Start by attaching your Tesla J1772 Charging Adapter to the charging station J1772 connector**, as you normally would. If this is your first time, follow the instructions included with your Tesla. Note how the J1772 connector attaches to the charging adapter with an attachment 'hook' that slides over a ridge on the adapter, to capture it. Figure 1, shows the adapter, in red – make sure the hook is clipped to the adapter ridge.

**Next, slide the CapturePro lock over the charging adapter**, as shown in Figure 2. The wide end of the lock goes onto the adapter first, and slides forward onto the adapter. Slide it on smoothly until the lock is close to the engagement hook (lock shown in red).

Now, position the CapturePro lock so that it slides over the hook on the charging wand. To support various hook sizes, CapturePro is designed with six different hook capture slots; rotate the lock to select the slot which best captures the hook. **Try each slot to find the one that achieves a tight fit without stretching the plastic body**; the hook should stay locked to the adapter ridge, but when the wand pushbutton is pressed (see Figure 4) it should have enough movement to trigger the internal electrical disconnect switch. Ideally, when pressed the button would click, but the hook won't release from the adapter. This process is needed because different charging station connectors are made by different manufacturers. There's more info on the pushbutton in the *Charge Port Unlocking* section below.

Now that the CapturePro is correctly aligned over the hook, **press the lock fully into place**, as shown in Figure 3. **Try the release pushbutton to make sure it can depress**.

Now, **insert the locked converter arrangement** into the Tesla charge port. Charging should now begin.

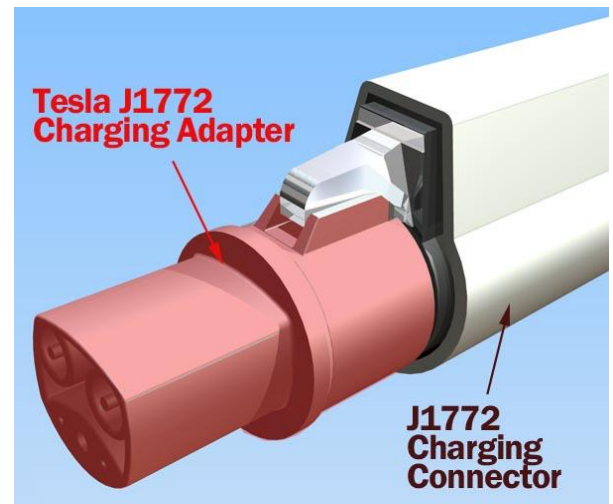

Figure 1

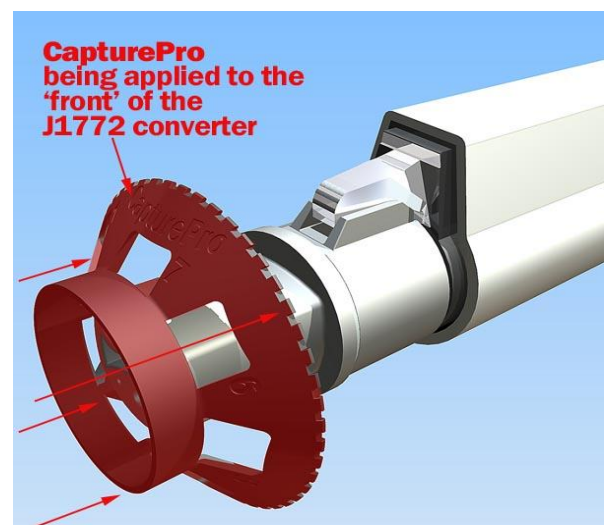

Figure 2

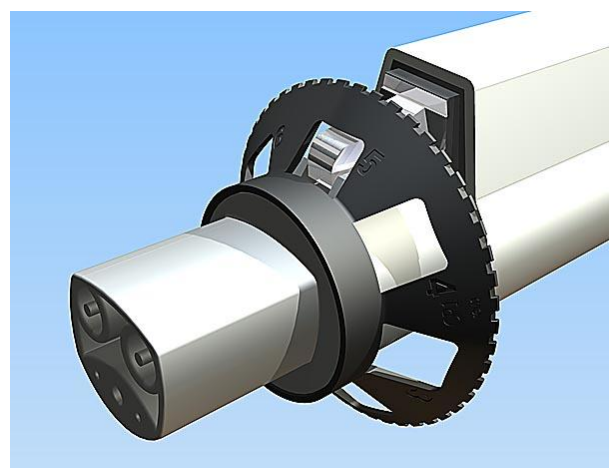

Figure 3

**TL:DR: Pick the slot that achieves a tight fit without stretching the plastic body – it should allow the button to press, but block release of the locking hook.**

## Ending your charging session when using CapturePro

### Charge Port Unlocking

When combined with CapturePro lock, your public charger is completely locked together as long as your Tesla is locked.

**First, Unlock your Tesla** with the fob, app or other mechanism.

Then the simplest way to unlock the charging port is to **press the disconnect button** on the J1772 charging connector handle. Figure 4 (right, arrow) shows the disconnect button location.

When the disconnect button is pressed the charger signals the car to end the charging session, the charge port then unlocks, and you can then remove the charger plus adapter arrangement from the car.

### Manual Unlocking Procedure:

**If the selected CapturePro slot holds the hook too tightly, the charger disconnect button may not depress enough to cause an electrical disconnection signal.** In this case, the car does not detect the request to end charging, so charging will not end and the charge port will stay locked.

In this case, simply move to the car's main screen and use the Charging controls to end charging manually, as follows:

1. Enter the **Charging** screen (depending upon model)
2. Press the **"Stop Charging"** button
3. Now press the **"Charge Port"** button (green arrow, lower left) on the main controls screen to unlock

Even though charging has ended, if the car is drawing more than 5A of 'shore power' (interior loads such as AC or heater) then you might have to disable these loads temporarily for **"Charge Port"** button to unlock

### Removal of Charging Hardware

Once the charge port is unlocked, the adapter + lock + charging connector can be removed from the car as a unit

Slide the CapturePro lock off the connector engagement hook

And finally, press the charging handle disconnect button again to mechanically raise the hook from the adapter slot, allowing the charging adapter to separate from the charging station connector "handle". Put the adapter and CapturePro away for later use.

### Emergency removal instructions

In the **very unlikely** case that a software update or failed electronics prevents the unlocking and removal of your charging adapter, you can remove the CapturePro device with **diagonal wire cutters**, or you can stretch and break the body material with a **screwdriver**.

**Power12 does not expect this situation – it is stated for safety reasons only.**

**Alert Power12 to any situation of this type – we will replace your broken CapturePro (customer pays shipping only)**



Figure 4



Figure 5

## Product Details

The CapturePro lock is an ABS-plastic device, designed to lock any Tesla Model S, Model X or Model 3 J1772 charging converter. It was designed to be strong, but also be removable with wire cutters or a screwdriver without damaging the port or the body.

## Label System

A labeling system is provided for use with the CapturePro. It consists of:

- A red label for the CapturePro, proper – this label indicates the locked condition of a properly assembled and locked charging adapter and indicates to others that **you want to continue to use the charging station, uninterrupted**



- A set of two green labels for optional use on your Tesla J1772 adapter – these labels are applied to each side of the adapter to indicate **it is OK for another EV user to disconnect the charging station** – see [Suggested Use Model](#) below. Additionally, the label leaves room to add an emergency contact number, allowing the next user to alert you to their requirement.

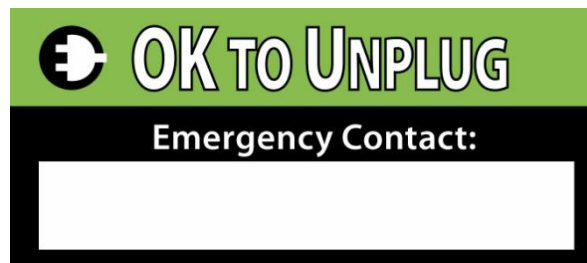

## Suggested Use Model

For each charging session:

**If you require the use of the charging station for your needs**, then use the CapturePro lock – the labels were designed so that when the CapturePro is utilized it covers the J1772 adapter label such that “OK to Unplug” is not visible, but the emergency contact number is visible.

**If you are charging your Tesla opportunistically, but the additional charging power is not required to achieve your travel goals**, then consider charging without the CapturePro lock – simply use the Tesla adapter as you normally would; in this situation the “OK to Unplug” green label will show, as well as your contact number. This will let others know that you can be disconnected.

Power12 strongly recommends that CapturePro users disconnect from a public charging station immediately once charging is complete, whether using CapturePro or not.

Failing to disconnect needlessly denies the charger to other users.

Also consider displaying your contact data so that others may alert you when they are in critical need of recharging.

## Applying the Optional Label System

**To add the red label:** orient the CapturePro body with large ring down; remove the red “Locked” label from the label page, and align the top edge of the label parallel to the top of the ring as shown below, centering it in the ring space; then wrap the label slowly around the ring – the label should overlap by about 1/10<sup>th</sup> inch, or less. Press the label in place firmly before use.



**Green Label:** Add the green labels to the J1772 adapter, as shown – apply each label starting at the J1772 adapter upper clip, with the plug logo and “OK” closest to the clip (labels are specific to each side). Align the upper edge of the label to the ridge – adjust until the label is square with the ridge – then slowly press the label against the adapter body around the outside edge. Attach the other label on the other side to complete the process.

There is room to optionally add your contact data (cell phone number, or mobile email) so that other charging users can alert you of their critical need for charging, or perhaps something which went wrong with your charging session.

We recommend using a permanent marker for contact data, in the white area.

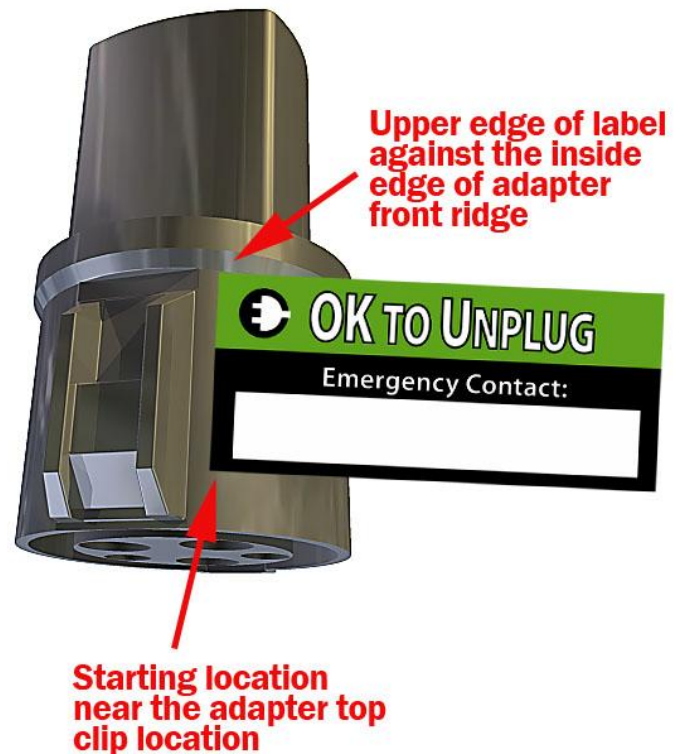

## FAQ

### Q: What does CapturePro do?

**A: It locks the Tesla J-1772 charging converter** to the J-1772 charging connector handle, thus protecting your charging session while you are away; J1772 is the public infrastructure which most people use in North America for charging when not at home. Since the Tesla charge port has a built-in locking mechanism for capturing the converter to the car, the CapturePro uses that mechanism to lock everything together, until you unlock the charging port.

### Q: What cars does the CapturePro support

**A: CapturePro protects the Tesla Model S, Model X, and Model 3** (as of 2018). It does not support the Original Roadster.

### Q: What are the red and green labels for?

**A:** The red label clearly indicates to other users that you are using the charger and it is locked. The green label optionally provides your emergency contact number, and indicates that others may remove the charger. Therefore, use CapturePro when you don't want others to disconnect the charger, and don't utilize it when you are OK with other EV owners removing the charger for their use.

Power12 suggests that all EV users show respect to other users by never leaving a charger connected to a car beyond the required time of charging – it needlessly denies others the use of the charger.

### Q: Does CapturePro have a warranty?

**A: Yes** - We warrant the construction of the CapturePro against failure due to material construction forever. Power12 reserves the right to refund the purchase price or replace with a new device.

Further, if your CapturePro is attacked or damaged, please contact Power12 for a free replacement (user pays only shipping).

### Q: What's the CapturePro made of?

**A:** It's an engineering polymer, meant to meet best compromise between strength in normal use, and removability in an emergency case where it must be removed. A metal part might, in a *highly unlikely situation*, permanently lock the Model S, Model X or Model 3 to a charging station and keep the car from moving from that location – this situation is unacceptable, so we utilized strong plastic which can be removed without damage to the car. Also, it allows predictable failure under direct attack, rather than causing damage to the car finish or failure of the charging system.

### Q: Which J-1772 connectors correspond to the CapturePro slot numbers?

**A:** Each charging network utilizes different charging handles, so it's hard to assure a specific size to be valid for each type. We simply suggest that users adjust the CapturePro each time for the best fit. Slot numbers are a reference for known stations.

### Q: Does the CapturePro touch the car body in any way?

**A: No.**

Note: the CapturePro is wedged snugly onto the J-1772 converter, and the Tesla charging connector traps the CapturePro between the converter and the car. Since the CapturePro is weaker than the charging connector, and it's wedged into that space tightly, so inserting, adjusting or removing the CapturePro **won't touch, scratch or mark anything on the car**.

### Q: What if someone tries to remove the CapturePro? What would they do, and could they damage the car or charger?

**A:** We considered this carefully in the design – we provide a strong locking function, but not enough to invite further efforts that would damage the charging system or the car in any way (including the paint/body). Therefore, if someone attempts removal with CapturePro in place, they would likely wedge a tool between the charging handle hook and the CapturePro, and not anywhere against the body of the car – this would likely break the lock cleanly and allow the bad actor to access the charger **without further efforts**. Note, they would still not be able to steal the Tesla J1772 Charging converter – it's exactly the same as a charging arrangement without the CapturePro: the converter stays locked until you unlock the charge port.