

CABINETS TO GO **WOW FOR LESS.**

ROLL OUT TRAYS (ROTRAY) ALL ASSEMBLY/INSTALLATION INSTRUCTIONS

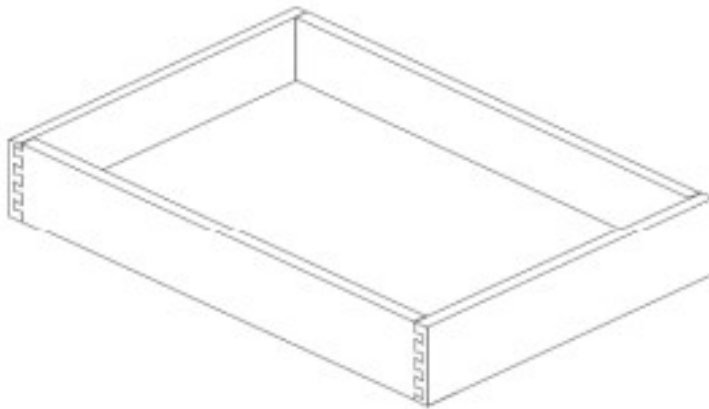

**ITEM# ROTRAY12, ROTRAY15, ROTRAY18, ROTRAY21,
ROTRAY24, ROTRAY27, ROTRAY30, ROTRAY33,
ROTRAY36**



ATTENTION: For questions or concerns about your cabinets, assembly or installation, please contact our dedicated Customer Care Team at **1-800-CABINET (222-4638)**. Our Customer Care associates are here for you every step of the way.

► **General Instructions:**

Thank you for choosing a Cabinets To Go product. You are now the proud owner of a high quality product designed to face the test of daily use and guaranteeing your enjoyment for many years to come.

Carefully read the instructions before starting the installation.







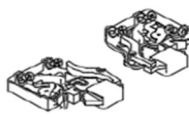

During assembly, please follow all generally accepted safety procedures.

Failure to adhere to the following instructions will invalidate the warranty and Cabinets To Go will decline any responsibility for any damages caused. Any installation which does not correspond to the instructions may result in defects, malfunctioning parts, significant damage and/or injury.

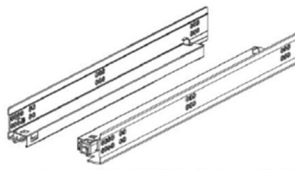
Before the assembly begins, check that all appropriate and required plumbing and electrical connections exist.

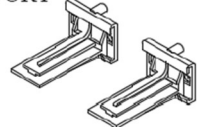
Before drilling, make absolutely sure that there are no pipes (gas, water, electricity, heating, etc.) at the drilling location. Cabinets To Go will not be held responsible for failure to follow these instructions.

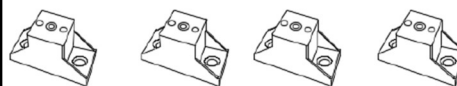
PRIOR TO ASSEMBLY, PLEASE MAKE SURE YOU HAVE ONE FACE FRAME BOX AND ONE CARCASS BOX, WHICH HAVE ALL THE PARTS IN THE QUANTITIES MENTIONED BELOW. If you are missing any parts, please STOP and contact Customer Care immediately at 1-800-CABINET.

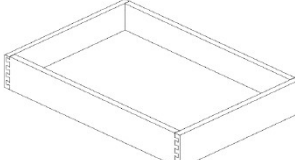
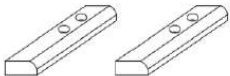
► Items Quantity	<p>LOCKING DEVICES</p>  <p>6*3.5x12</p> 	<p>SLIDES</p>  <p>10*3.5x16</p> 	<p>BACK SUPPORT</p>  <p>4*3.5x16</p> 
	<p>4 PVC SPACER</p>  <p>8*3.5x14</p> 	<p>TRAY BOX</p> 	<p>2 * 1/4" MOLDING</p> 

► **Required tools:**

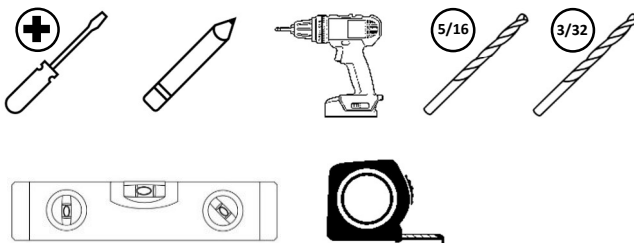

- PHILLIPS SCREWDRIVER
- PENCIL (MARKING DEVICE)
- DRILL
- 5/16" & 3/32" DRILL BITS
- LEVEL
- TAPE MEASURE

STEP 1

ATTACHING LOCKING DEVICES

- Align inside the bottom front of the drawer box. *Locking devices are labeled Left and Right.*
- *Place upside down in corresponding corner.*
- Screw into sides of drawer box, 3 screws per locking device.



Tip: *Avoid screwing the devices into the bottom of the tray box to keep the screws from puncturing the tray box*

STEP 2 – OPTION A (FRAME & BACK PANEL INSTALLATION METHOD)

INSTALLING THE BACK SUPPORTS

NOTE: For Option B, 1" Spacer Installation Method, Skip Step 2.



<p>Bracket - Centered</p> <p>The middle of the bracket can be moved left or right. When moved all the way to one side, this can be used as a guide against the side panel to mark where the holes need to be drilled for installation.</p>		<p>Bracket - Left Aligned</p> <p>This is an example of the middle of the bracket moved all the way to the left side.</p>	
---	--	---	--

<p>Left Side</p> <p>With the bracket left aligned, place against the left side panel and mark the top center of the bracket locator pin.</p>		<p>Marking & Drilling</p> <p>Using your marks and a level, make another mark 1 1/4" underneath it for the bottom locator pin. Using a 5/16" drill bit, drill the two marks at a minimum of 7/16" deep.</p>	
---	--	---	--

<p>Bracket - Right Aligned</p> <p>Move the bracket to the right position and repeat the previous steps for the right side panel, making sure you mark these the same height as the previous side using a straight edge/level or tape measure, etc.</p>		<p>Screw in place</p> <p>After the holes are drilled, insert the bracket and screw into place. Then you can proceed with installing the slides.</p>	
---	--	--	--

STEP 3

INSTALLING THE SLIDES

Option A – Frame & Back Panel Installation Method

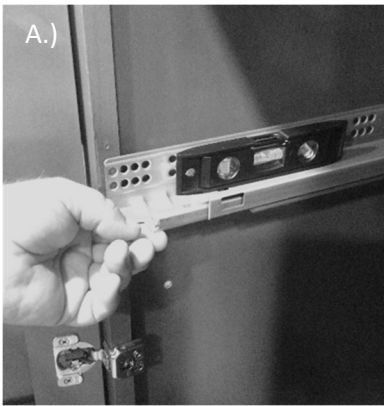
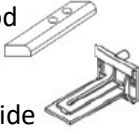

- Insert the slide into the back bracket installed in previous step and hold it level approximately 1/8" from the outside of the frame.

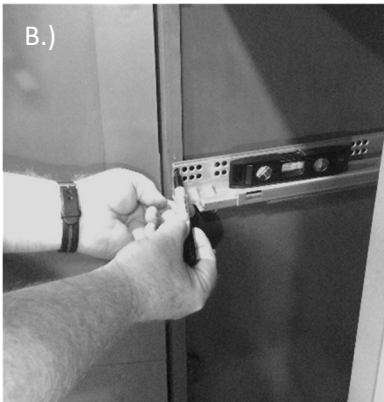

- Using a level, mark the first two vertical holes in the slide on to the frame. Then temporarily remove the slide again and set aside.



- Drill two pilot holes using a 3/32" drill bit in the center of the two locations marked on the frame.

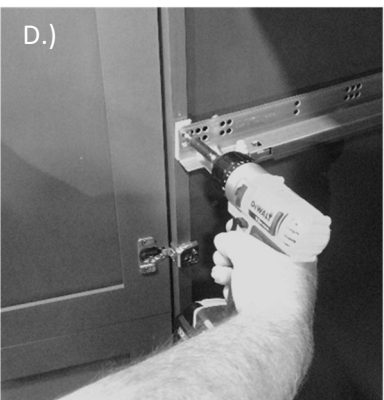

- Replace the slide into the back support, place the provided spacer between the frame and slide, and screw into place. Repeat steps for both sides. Then continue to Step 4.

Option B – 1" Spacer Installation Method

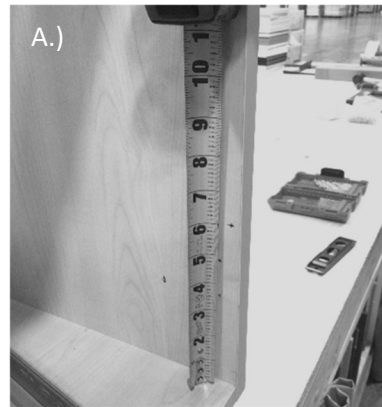

- Make a crosshair on the side panel; marking 1/2" from the front edge of the cabinet and marking at the height you want the bottom of the roll out tray. i.e. 6" in the pic.

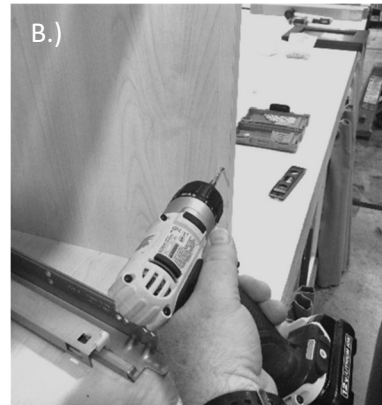

- Drill a pilot hole using a 3/32" drill bit in the center of the crosshair marked on the side panel.



- Insert a screw into the bottom of the 1" spacer and into the pilot hole.



- Using a level, mark the top hole of the spacer. Drill pilot hole and insert top screw as in steps B & C. Continue to Option B step E.

STEP 3 – OPTION B CONTINUED

INSTALLING THE SLIDES

OPTION B – 1" Spacer Method

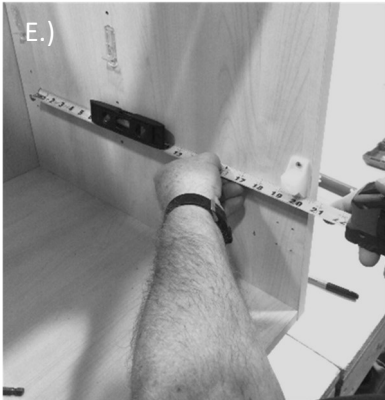

- Using a tape measure and level, measure 20 1/2" from the edge of the cabinet and make a crosshair mark at that point and at the height previously chosen. i.e. 6" in the pic.

{REPEAT OPTION B STEPS B – D FOR THE BACK SPACER}

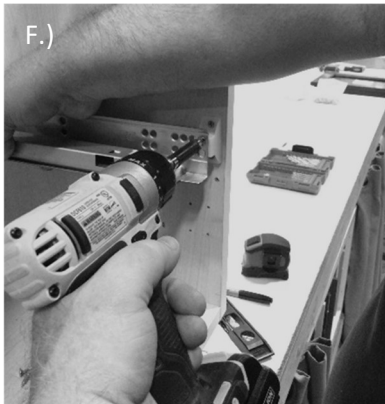

- Install the slides onto the 1" spacers, repeat all Option B steps A - F for the other side, then continue to Step 4 below.



- NOTE: With the slide installed properly it should be level. This is an example of an installed slide.



- NOTE: This is an example of how the installed roll out tray will look using Option B.

STEP 4

INSERT DRAWER

- Place the drawer on the rails, paying attention to line up the notches and holes in the back of the tray.
- Push the tray to the back of the cabinet until you hear it lock into place.

NOTE: This is how the installed ROTRAY should look.

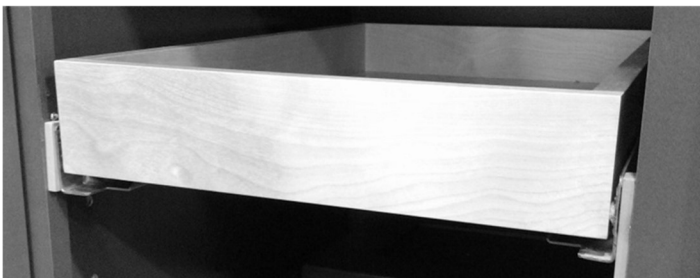

► **Maintenance**

For daily cleaning, use a dry cloth and a soft liquid cleaner.

Never use abrasive cleaners containing acetone, chlorine or strong bleach. Also, do not use tools as scrapers, metallic brushes, and other products which can scratch or tarnish surfaces.

Under no circumstances should you use chrome cleaner on chrome-plated or brass trim, hinges, handles, sockets etc.

Good ventilation is essential for maintaining the quality and look of this furniture.

Warranty and Customer Care Information

For the most up to date warranty information for your product, please visit our website - www.cabinetstogo.com to get the specific details. If you have any questions with warranties or to make a claim, please contact Customer Care by email - customer care@cabinetstogo.com or call 1-800-CABINET.