

## Base Cabinet ASSEMBLY INSTRUCTIONS

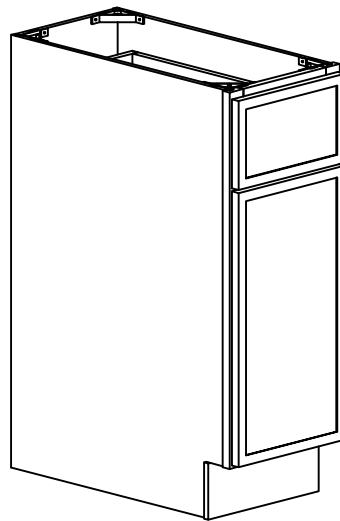

These assembly instructions are only applicable for Base Cabinets

BC12 BC15 BC18 BC21



**ATTENTION:** For questions or concerns about your cabinets, assembly or installation, please contact our dedicated Customer Care Team at 1-800-CABINET (222-4638). Our Customer Care associates are here for you every step of the way.



► **General Instructions:**

Thank you for purchasing a Cabinets To Go product. You are now the proud owner of a high quality product designed to face the test of daily use and guaranteeing your enjoyment for many years to come.

Carefully read the instructions before starting the installation.

During assembly, please follow all generally accepted safety procedures.

Failure to adhere to the following instructions will invalidate the warranty and Cabinets To Go will decline any responsibility

Before the assembly begins, check that all appropriate and required plumbing and electrical connections exist.

Before drilling, make absolutely sure that there are no pipes (gas, water, electricity, heating, etc.) at the drilling location. Cabinets To Go will not be held responsible for failure to follow the instructions.

PRIOR TO ASSEMBLY, PLEASE MAKE SURE YOU HAVE ONE FACE FRAME BOX AND ONE CARCASS BOX, WHICH HAVE ALL THE PART IN THE QUANTITIES MENTIONED BELOW. IF YOU ARE MISSING ANY PARTS, PLEASE STOP AND CONTACT CUSTOMER CARE IMMEDIATELY AT 1-800-CABINET.

► **Items Quantity**

Item.	Description	Q'ty
A	SIDE PANEL	2
B	BACK PANEL	1
C	BOTTOM PANEL	1
D	TOE KICK	1
E	FRAME	1
F	DOOR	1
G	DRAWER FRONT	1
H	DRAWER BOX FRONT	1
I	DRAWER BOX BACK	1
J	DRAWER BOX SIDE	2
K	DRAWER BOX BOTTOM	1
L	SHELF	1

► **Required tools:**

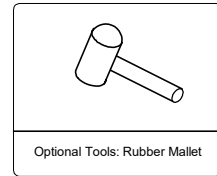
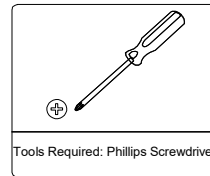

**Hardware Box**

No.	Description	Q'ty	Picture
a	HINGE OVERLAY: 1-1/4"	2	
b	0.47" FLAT HEAD SCREW	4	
c	0.75" FLAT HEAD SCREW	4	
d	21" SELFCLOSE SLIDE	1	
e	1" FLAT HEAD SCREW	11	
f	PLASTIC CORNER	4	
g	0.56" FLAT HEAD SCREW	12	
i	PLASTIC SHELF SUPPORT	4	
J	REAR CLIPS	2	
k	Locking Device	2	
l	0.39" FLAT HEAD SCREW	2	
n	0.6" FLAT HEAD SCREW	4	

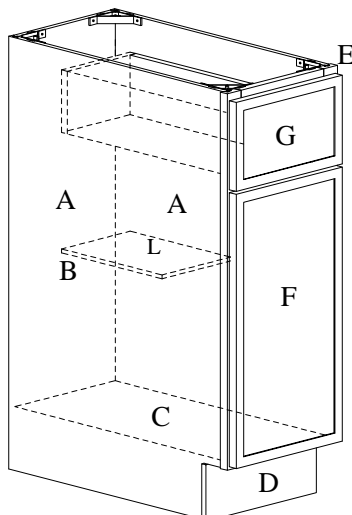

The material above are for the largest unit in this instruction set. Smaller units may require less hardware and material: Therefore, your item may contain a smaller number of each.



► Instructions:

1. Place the side panel (A) face down on a flat soft working surface to ensure that the face is not scratched or damaged. (Figure 1).

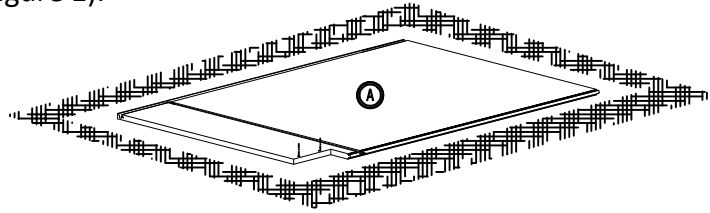

2. Install the Back Panel, bottom, toe kick: Insert the back panel (B), the bottom (C) and Toe kick (D) into the groove of the side panel (A) and click it into place. (Figure 2)

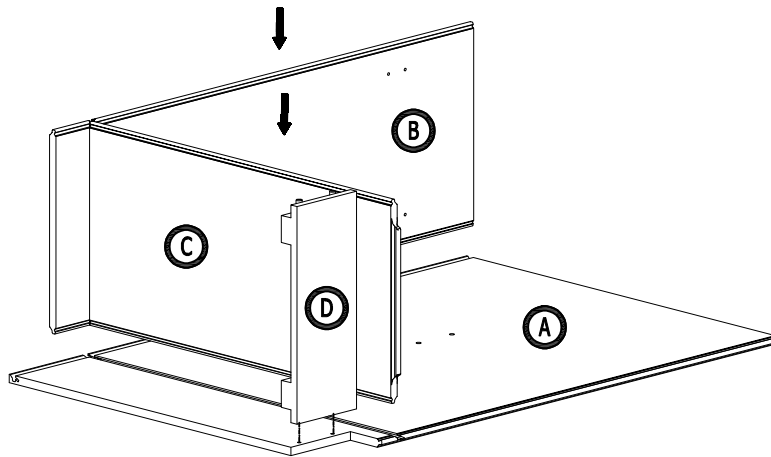

Figure 2

3. Installing the side panel: Insert the side panel (A) into grooves of back panel (B) & bottom (C) and toe kick (D). Press down until they click into place. (Figure 3)

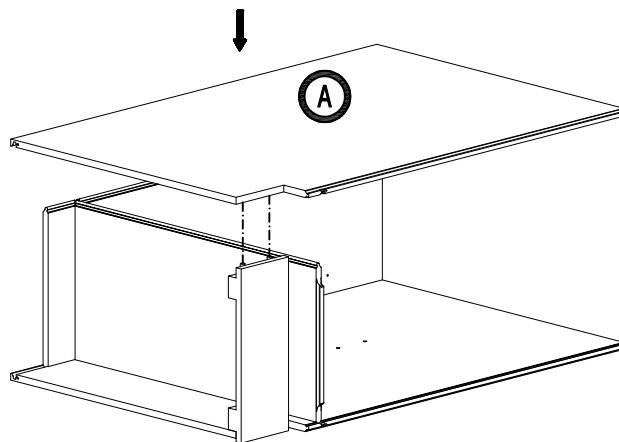

Figure 3



4. Install the frame: Insert the frame (F) into the groove of the side panel (A), bottom (C). Press down until they click into place. (Figure4)

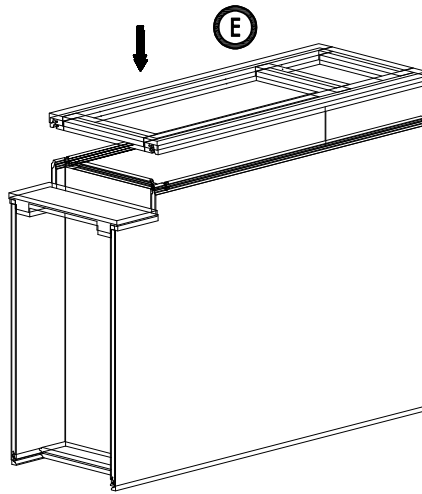
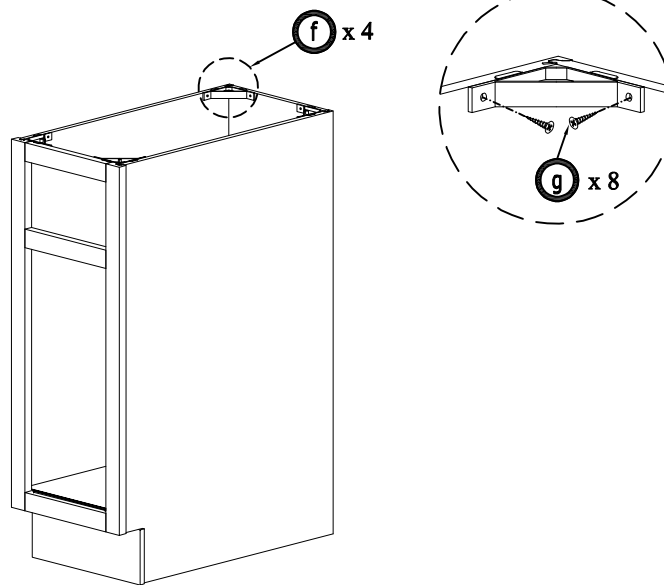

Figure 4

5. Assemble 4 plastic corner by screwdriver and 8 screw 1/2" (Figure 5)



6. Assemble 2 hinges into two doors by screwdriver and 4 screw 7/15" (Figure 6)

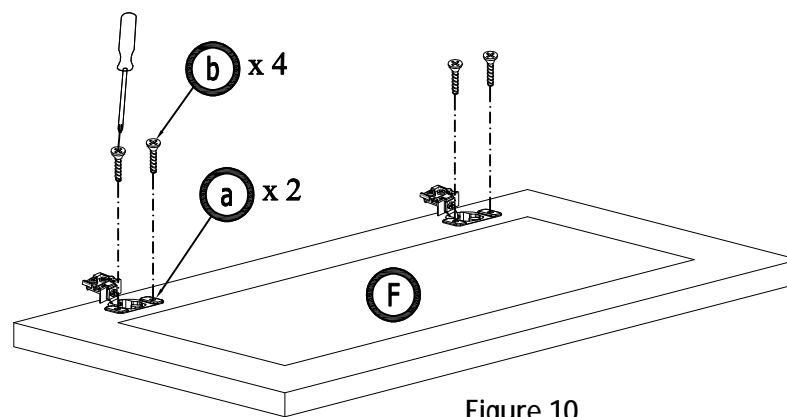
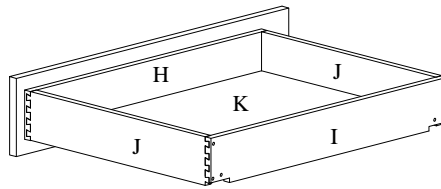

Figure 10

## 7. Assemble the drawer



1. Install the drawer bottom into drawer box back, click into place (Figure 1)

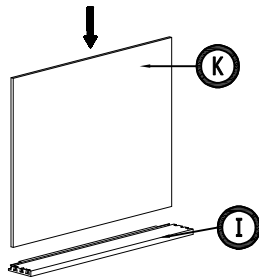

Figure 1

2. Install the drawer front into groove of drawer bottom, click into place (Figure 2)

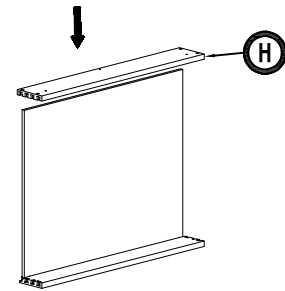

Figure 2

3. Install the drawer side into drawer back, drawer box back and front, click into place (Figure 3)

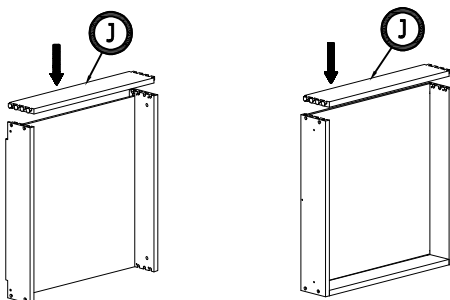

Figure 3

4. Assemble screw 1" into drawer back with drawer side and drawer front with drawer side (Figure 4)

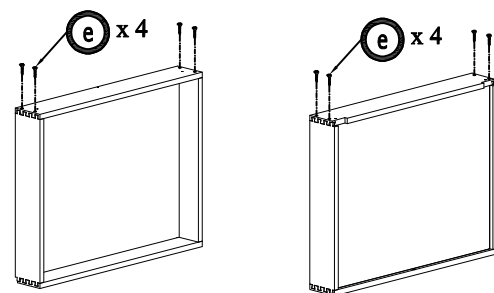

Figure 4

5. Assemble the screw 1" from drawer box front with drawer front into the free hole in the drawer front (Figure 5)

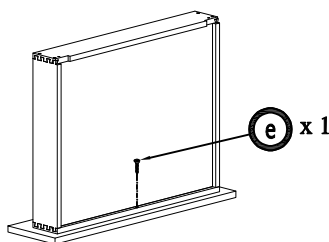

Figure 5

6. Assemble the screw 1" from inside of drawer box front with drawer front into the free hole in the drawer front (Figure 6)

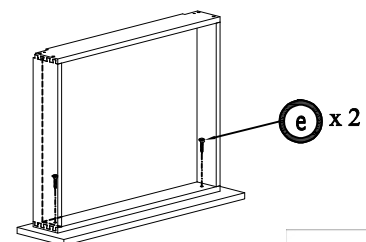

Figure 6



•Assembly is made fast and easy with ThreeSpine® click furniture technology.  
 •Patent Protected, [www.vallings.se/patents](http://www.vallings.se/patents)  
 •Produced under license from Vallings Innovation.



8. Assemble the drawer runner inside of cabinet with 2 screws 9/15" (e) for each side  
Put plastic block into free hole in the back panel (B) .(Figure 8)

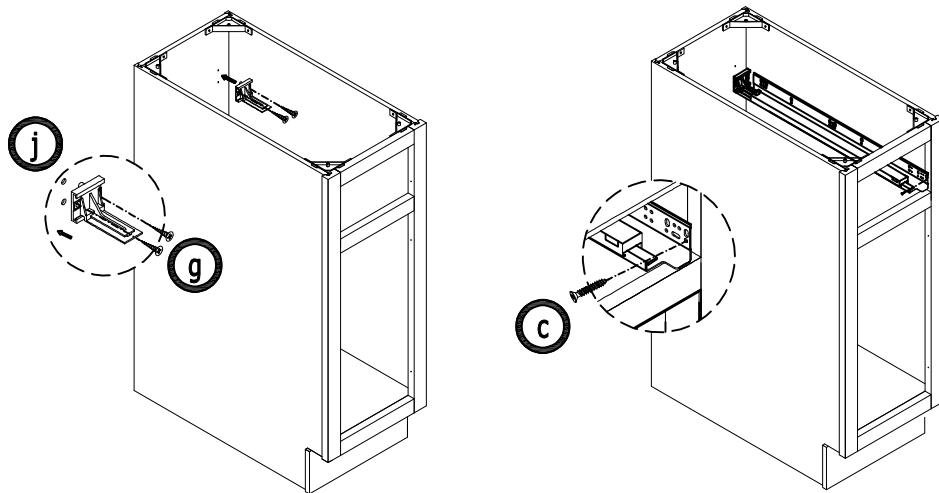

Figure 8

9. Assemble 3D locking device with 3 screws 6/15", to move out the slide and put drawer to click into the hook of slide with the hole in back side of drawer back . 3D locking device can just the drawer up/down, Left/Right or in/out .(Figure 9)

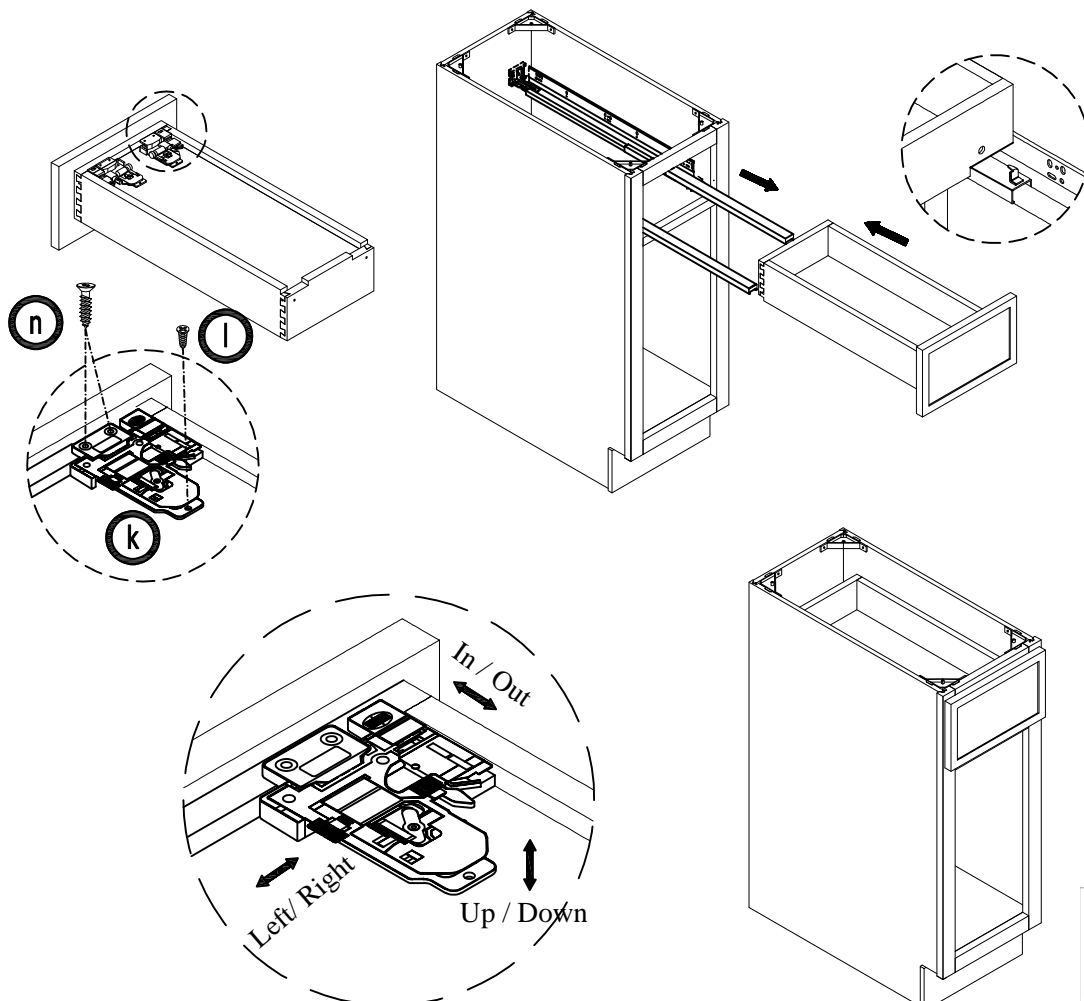

Figure 9



•Assembly is made fast and easy with  
Threespine®'s click furniture technology.  
•Patent Protected,  
[www.threespine.se/patents](http://www.threespine.se/patents)  
•Produced under license  
from Välinge Innovation.



10. Assemble door with hinges to left and right of cabinet frame by 2 screw 4/5" (Figure 10)

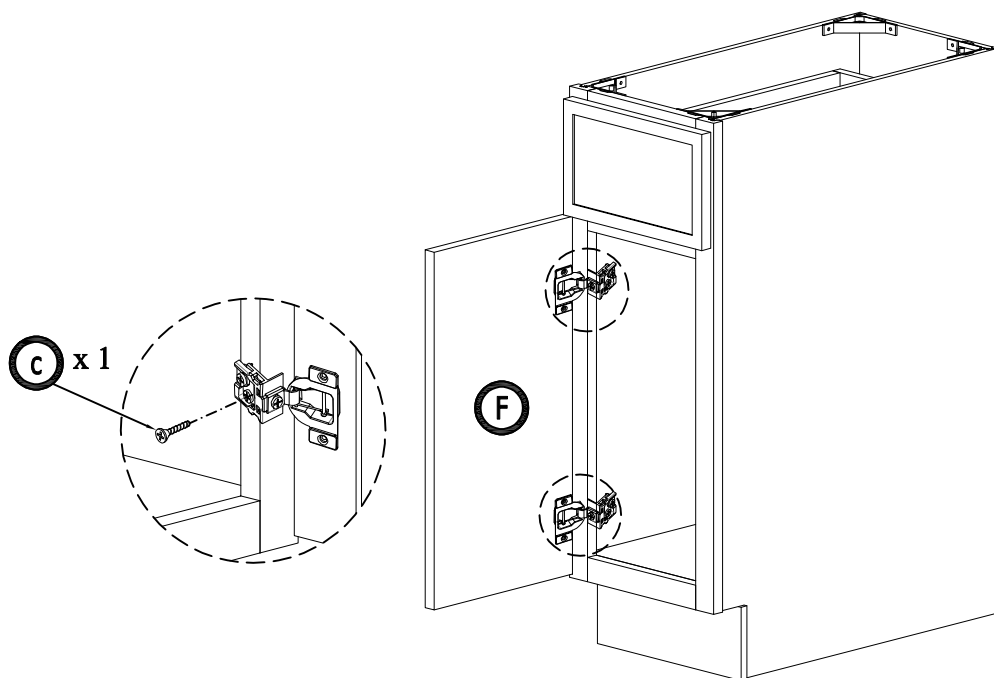

Figure 10

11. installing the shelf inside of cabinet: Insert plastic shelf support into the free hole inside of side panel and put the shelf on the support. (Figure 11)

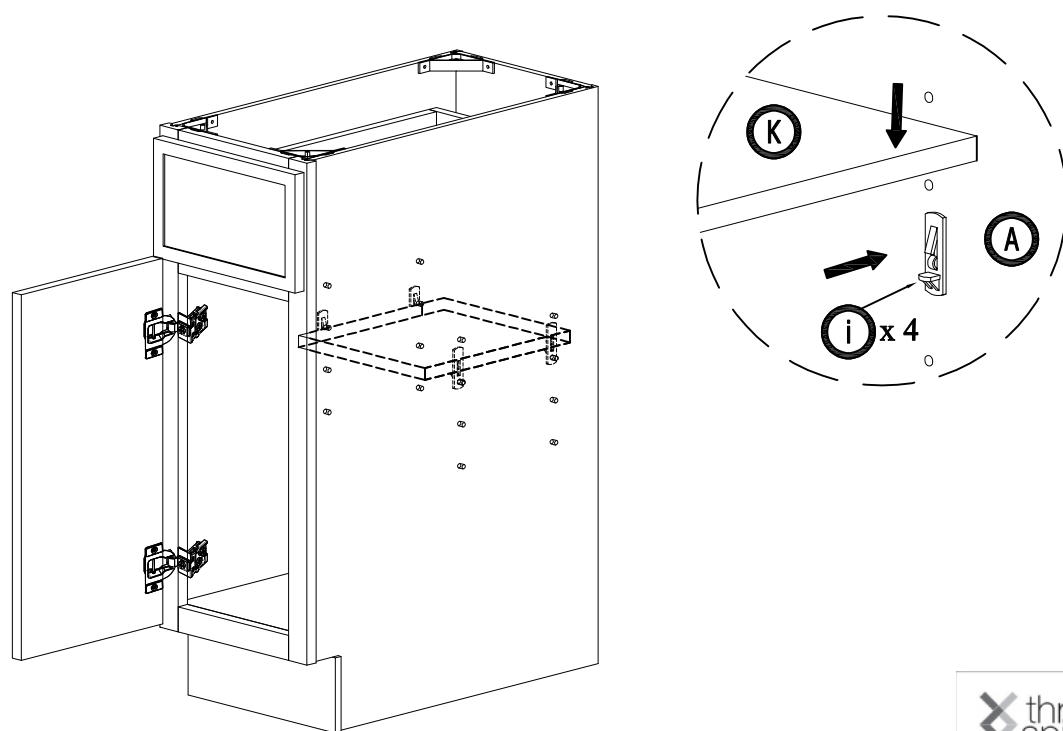
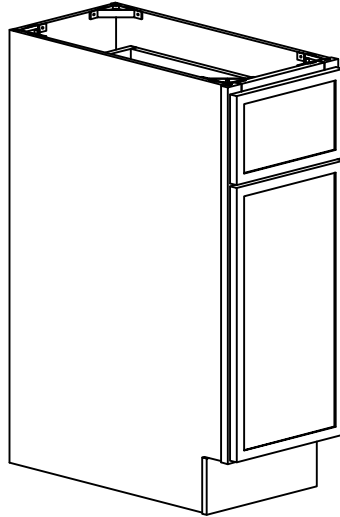

Figure 11



•Assembly is made fast and easy with  
Threespine®'s click furniture technology.  
•Patent Protected,  
[www.vallings.se/patents](http://www.vallings.se/patents)  
•Produced under license  
from Vallings Innovation.





► **Maintenance:**

**For daily cleaning, use a dry cloth and a soft liquid cleaner.**

**Never use abrasive cleaner containing acetone, chlorine or strong bleach. Also, do not use tool as scrapers, metallic brushes, and other products which can scratch or tarnish surfaces.**

**Under no circumstances should you use chrome cleaner on chrome-plated or brass trim, hinges, handles, sockets etc.**

**good ventilation is essential for maintaining the quality and look of this furniture**

**Warranty and Customer Care Information**

**For the most up to warranty information for your product, please visit our website - [www.cabinet.comto](http://www.cabinet.comto) to get the specific details. If you have any questions with warranties or to make a claim, please contact customer care email - [customercare@cabinettogo.com](mailto:customercare@cabinettogo.com) or call 1-800-CABINET.**



\*Assembly is made fast and easy with  
Threespine®'s click furniture technology.  
\*Patent Protected,  
[www.vallings.se/patents](http://www.vallings.se/patents)  
\*Produced under license  
from Vallings Innovation.

