

Applications

- Industrial Machinery
- Robotics
- Commercial Wiring
- Low Voltage Control System
- Solar Industry

Specifications

Mechanical

- Length: 4.330 in (110 mm)
- Width: 2.559 in (65 mm)
- Height: 1.772 in (45 mm)
- Weight: 0.34 lb (183 g)
- Material: ABS Base & Cover
- Connection Capacity: 14 - 20 AWG(0.5 - 2.5mm²)
- Wire Entry: Molded Knock Outs
- Entry Opening: 13/16 in (20mm)
- Trade Size: 1/2 NPT
- Neoprene Gasket In Cover
- Mounting Hardware: (2) PH - M4 x 30 with Hex Nut

Electrical

- Input Current: 15 Amperes
- Rated Frequency: 60 Hz
- Rated Input Voltage: 120 Volts
- #6 Screw Terminal
- Terminations: 20 / Circuits: 10

Safety

- Certifying Agency: TUV-SUD
- Countries: Canada, USA
- Standards: UL 508A
- Ingress protection: IP65*
- *When IP65 or Higher Rated Cable Gland is used

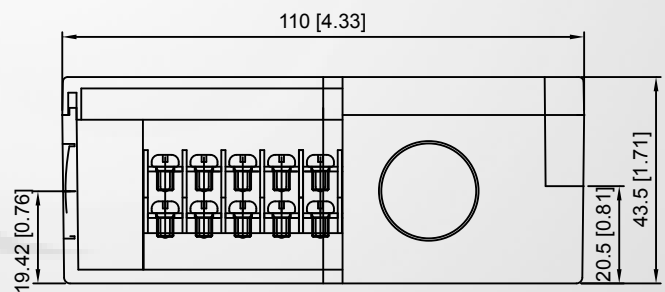
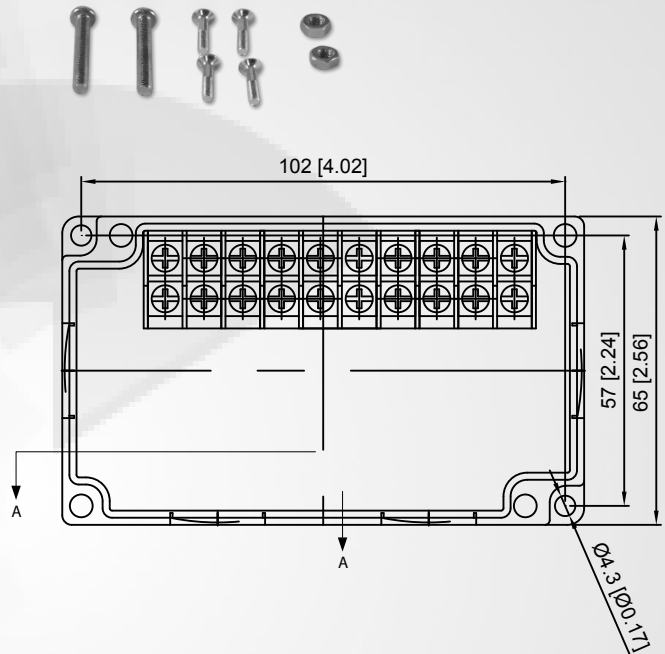
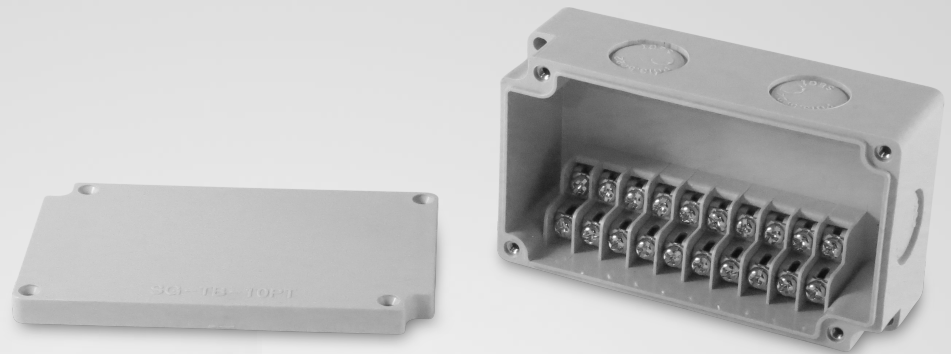

SECTION A - A
SHOWN WITH COVER

Compatible Accessories



SG-BB-10 (Red)



DS-PG-13.5 (Grey)
DS-PG-13.5BLK (Black)