

NOTICE!

It is recommended to have painted and finished your designs on the body of the ukulele, using commercial wood paint, or basic acrylic paint, before assembling it. Check your local art stores for paint and varnish varieties that can be applied without any technical knowledge.

Before you start painting, sand off any surface irregularities with fine sandpaper (800+). Make sure that all surfaces on the instrument are free of dust and dirt. It is recommended that you first try out the color and technique on another piece of wood.

After letting the paint dry completely, polish or varnish the ukulele to seal and protect the instrument and your artwork. Sand off any irregularities with fine sandpaper (800+), and reapply the polish or varnish depending on the type of finish you want. Make sure not to polish too strongly and end up removing your paint.

Materials Needed

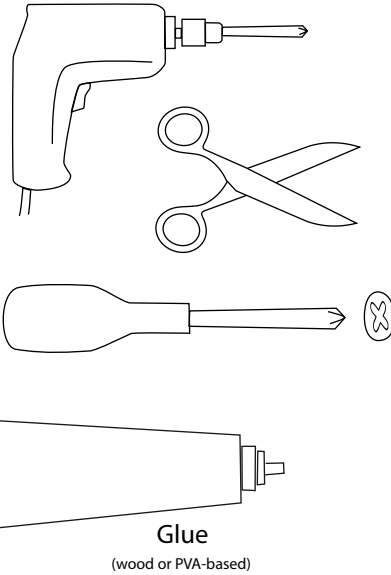

1

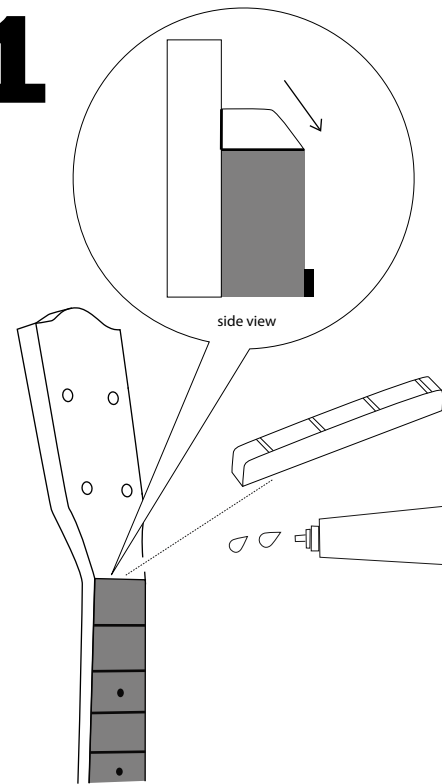

2

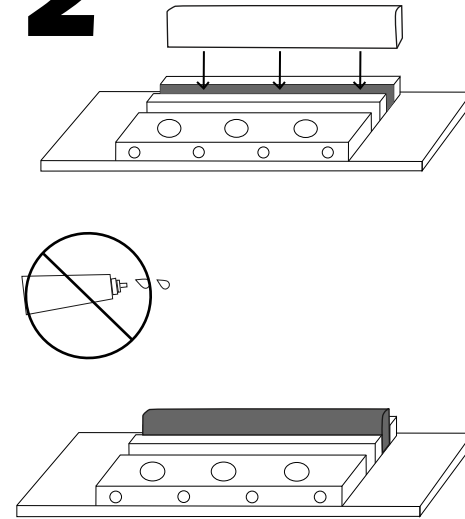

3

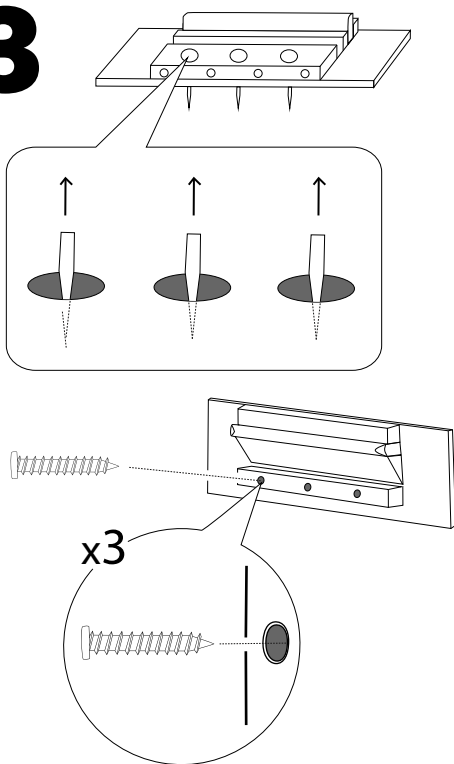

4

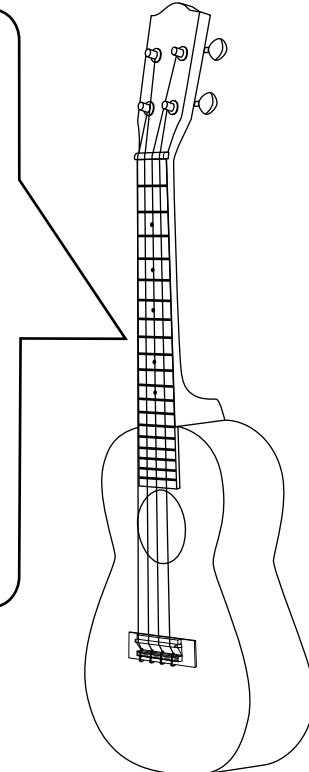
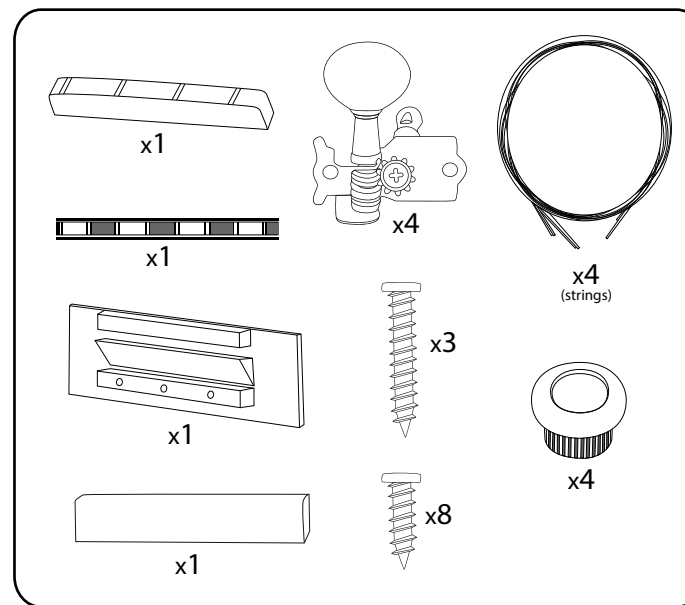
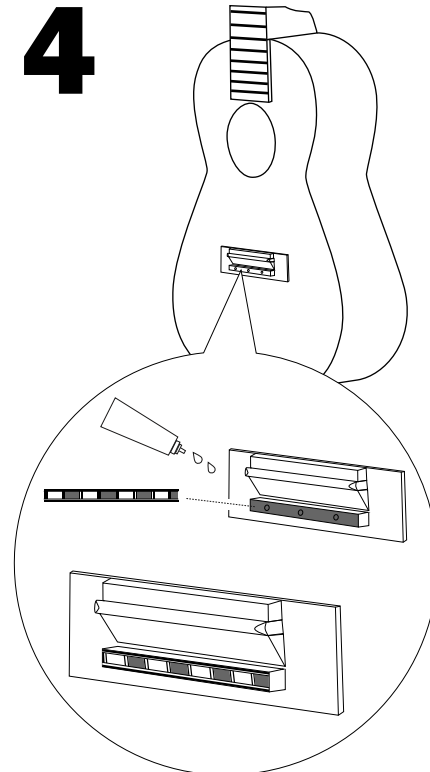

Ohana
ukuleles

CK-KIT
Designed and inspected
in California
Made in China

5

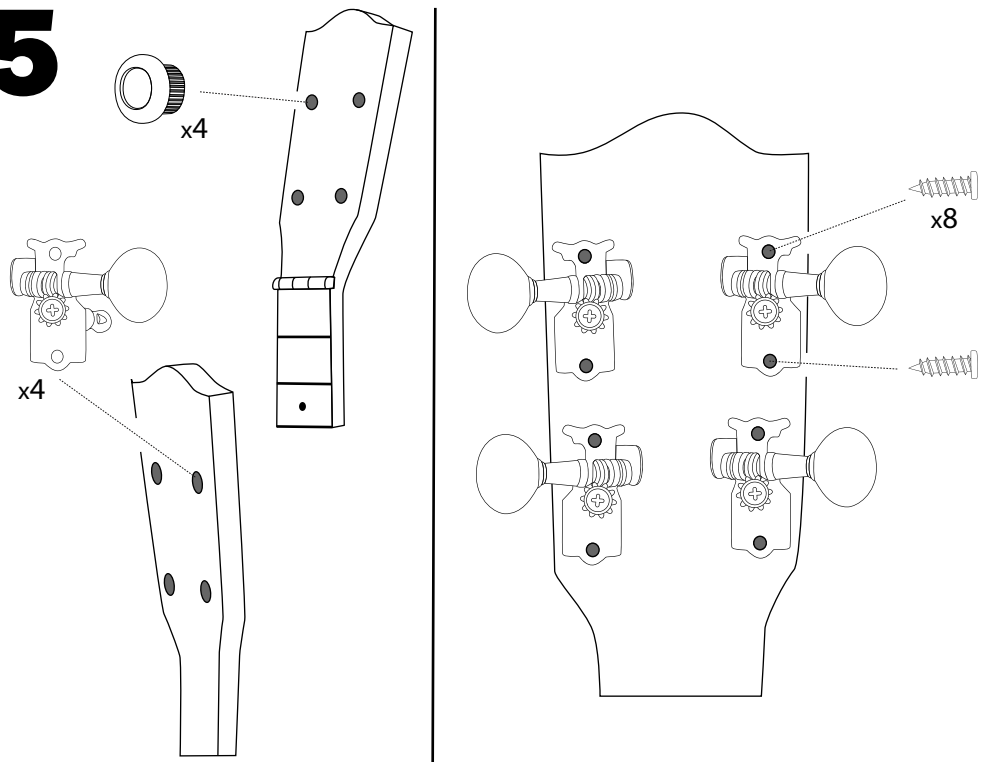

6

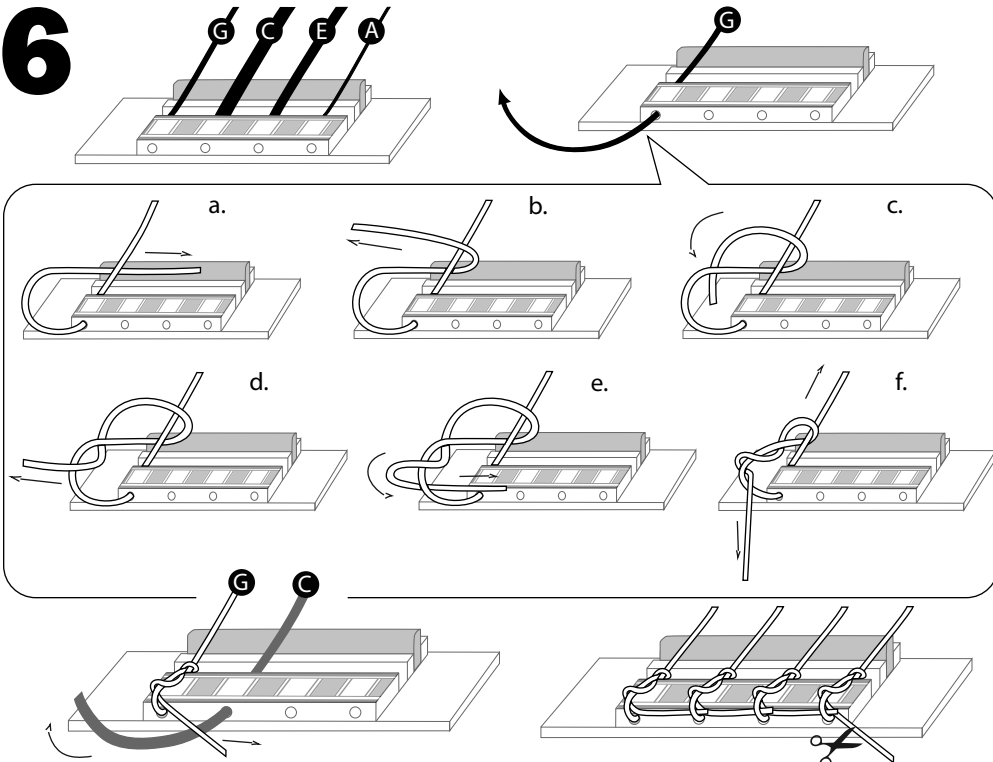

7

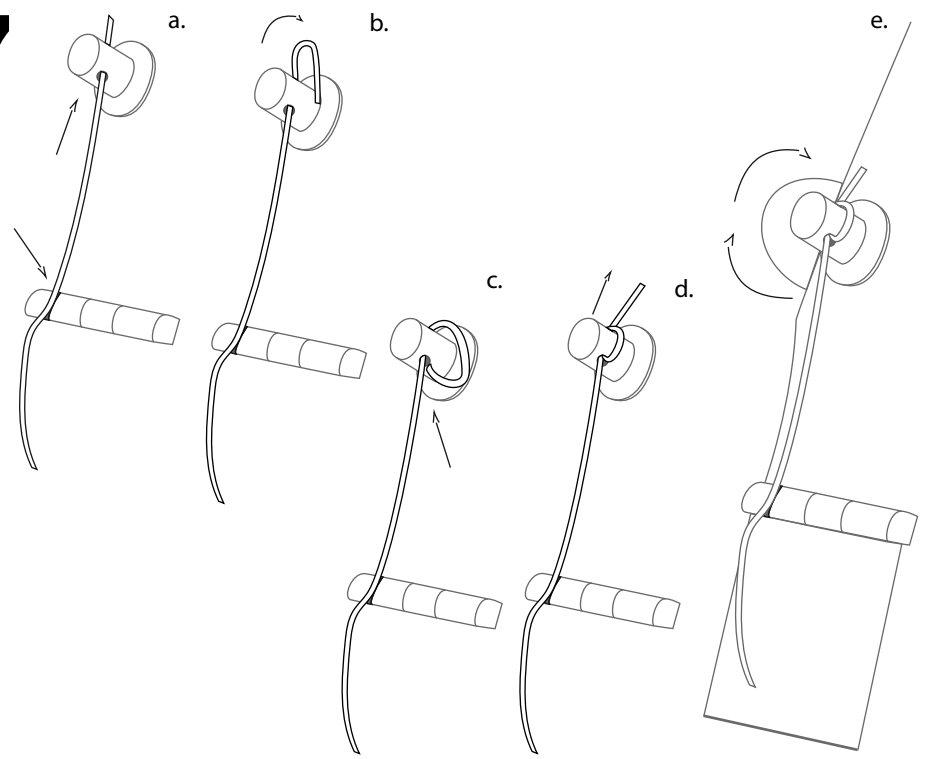

8

