

ZEISS MyoCare

A new category of ZEISS myopia control lenses. Ensuring good vision and myopia management for all viewing angles.



With ZEISS MyoCare, ZEISS introduces a new lens category for myopia progression management.



Seeing beyond

ZEISS MyoCare

Inspired by the ring-like imprints on the cornea following orthokeratology treatment, the design of ZEISS MyoCare adopts annular cylindrical microstructures to induce simultaneous competing myopic blur on the peripheral retina to slow down the progression of myopia. The patented Cylindrical Annular Refractive Elements (C.A.R.E.) Technology incorporates alternating defocus and correction zones expanding towards the periphery of the lens. The design is focused on myopia progression control, while preserving wearability. Eyes are constantly moving and therefore ZEISS MyoCare lenses feature with the ZEISS ClearFocus design an optimized back surface, not only providing the correct lens power but minimizing unwanted hyperopic defocus independent of gaze direction. This together ensures good vision and intended myopia management for all viewing angles.

Myopia beyond a vision problem

Myopia is becoming more common across the globe.

Epidemiological studies show a higher prevalence and earlier onset of myopia in many parts of the world, making it a major public health issue.^[1] At the same time the awareness is rising that linked to the level of severity, myopia may have not only an impact on quality of life but can also be associated with a risk to develop serious eye diseases in the long term.

There is extensive evidence that the situation is most urgent in East Asian countries, with highest growth rates and the most pronounced increase in myopia prevalence – reaching up to 90% among Chinese students in urban areas.^[2] Answering this need, ZEISS is looking back at decades of basic and clinical myopia research, building the foundation for a portfolio of myopia management lens solutions. Leading with science, ZEISS myopia management lens solutions were always developed in parallel to the progress in scientific understanding and the advancing knowledge about how to put a break at myopia progression. Their successful application in the market made ZEISS the leading supplier in ophthalmic lens solutions for myopia management in the region where the situation is most urgent.

The landmark study from Holden et al. in 2016 on global estimates for myopia prevalence predicted that 50% of the world's population may be myopic by 2050, stipulating that what can currently be seen in East Asia has the potential to become a global epidemic.^[3] Across the world, lifestyle has changed and continuously changes, creating conditions that trigger the myopization of children. From early on, ZEISS therefore decided to monitor and map the situation outside of East Asia and started collecting data to advance our understanding of refractive development in Caucasian children, to provide this essential information and necessary insights to act upon.

Already in 2014, ZEISS partnered with the Leipzig Research Center for Civilization Diseases of the University of Leipzig, who started the LIFE Child study in 2011 – one of the biggest population-based longitudinal cohort studies that are currently running in Europe. The LIFE Child study aims to monitor child

development from birth to adulthood and to understand factors associated with health and disease, with a particular focus on lifestyle diseases such as overweight, allergies and – since partnering with ZEISS – also refractive development. The so-called eye health cohort now consists of approximately 2000 children aged between three and 16 years. These participants are invited year by year to attend annual follow-ups where refraction, visual acuity and axial length of the eye are recorded and monitored longitudinally. In addition to this academic approach, ZEISS partnered with Euronet Market Research to analyze ocular history data collected in over 400 optician shops distributed all over Germany from more than 500.000 subjects aged between 0 and 20 years to validate that the study results reflect what is observed in real-world eye care practices.

The data collected within the LIFE Child study shows that the myopia prevalence in Germany is very low at young age, ranging up to 10% until 10 years of age (Figure 1).^[4] With increasing age, the prevalence of myopia increases. The results reflect the findings from similar studies across Europe, which together show a very low prevalence among children before school-age (on average 2-3 % in up to 6-year-olds) and a gradual increase in children attending primary school (about 11 % in 7 to 10-year-olds) and secondary school (20 to 30% in 11 to 17-year olds).^[5]

Extending these findings, a meta-analysis from 2015 summarizing the results from 15 population-based adult cohort and cross-sectional studies across Europe determined an overall age-standardized myopia prevalence of 30.6 %.^[6] Further analyses looking into different age groups thereby revealed a peak prevalence of 47.2 % in young adults aged 25 to 29 years, which was almost double the rate observed among those of middle to older age (27.5 % in those aged 55-59 years).

Even though these studies point to a similar trend of higher myopia prevalence in the last 20 to 30 years across Western and Northern Europe, in comparison to East Asian countries, where the myopia rate among Chinese students below the age of 20 is now more than 80 %, reaching up to 90 % in urban areas^[2], the absolute numbers are much lower. Likewise, the prevalence of high myopia is by far more severe in East Asia, reaching up to

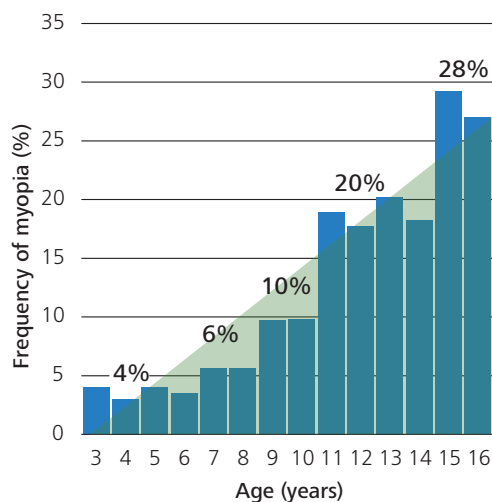

Figure 1. Prevalence of ametropia in the LIFE Child study based on non-cycloplegic autorefraction measures. Myopia was defined as $SE \leq -0.75D$ according to recommendations from the International Myopia Institute. Adapted from Brandt et al. 2021.^[4]

20 % in young adults, while in Europe the rate of high myopia is with 2 to 3 % relatively low.^{[6], [7]}

This is also well reflected by comparing growth charts between these populations. Growth charts display the standard or physiological growth within a specific population with norm curves, the so-called percentiles. The percentile curves describe the statistical distribution of values obtained from observations with many participants from defined age groups in individual countries or continents. Growth charts are essential tools typically applied in clinical practice of pediatric care to track the growth of infants, children and adolescents with selected body measurements as an important indicator of a child's health. The data collected in the LIFE Child study provides the first growth chart for refractive development specifically in children from central Europe, as well as reference curves for the growth of the eyeball, i.e. axial length.^{[8], [9]} These reference curves allow health care professionals to monitor a child's refractive development and identify children at risk for progressive and high myopia.

Figure 2 shows the growth charts for axial length for children from central Europe, based on the data of the LIFE Child study, and comparable data from a study cohort of Chinese children.^[9] As can be seen by superimposing the curves on each other, parts of them are far apart: while there is only little difference at very young age, and across all lines, there is a trend towards myopia with increasing age, myopia progression is much higher in East Asia than in Germany. Similar studies in European children show that an axial length exceeding the 75th percentile indicates a high risk for the development of high myopia.^[10] Comparing the 75th percentile further exemplifies the big difference in axial length and myopia prevalence between Europe and China.

Even though the absolute numbers of myopia prevalence and myopia progression are lower in Europe, still there are also children who are in need of myopia management. This is well

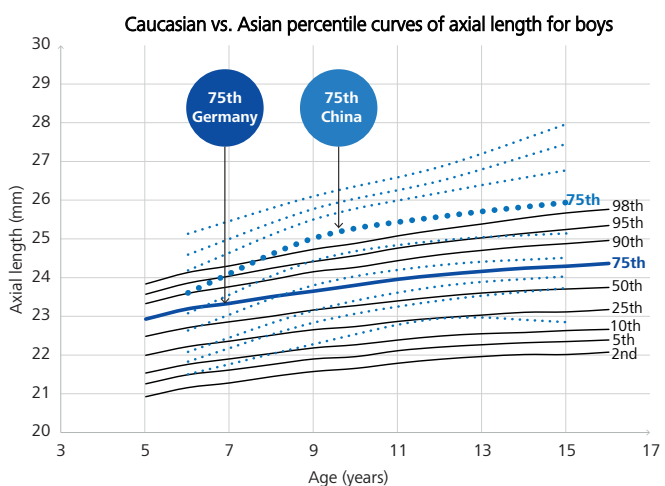
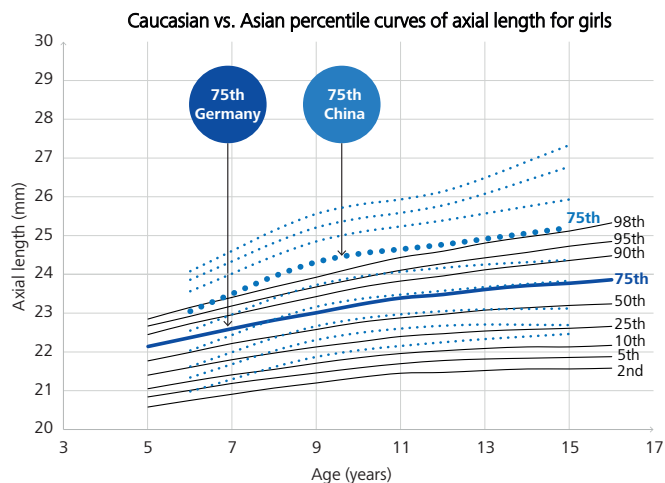

Figure 2. Growth charts with percentile curves of axial length. The solid lines show the LIFE Child Study results (Germany) separated for girls (upper panel) and boys (lower panel). The dashed lines show comparable results from a study cohort of Chinese children from Wuhan, China. Adapted from Truckenbrod et al. 2021.^[9]

reflected in the longitudinal data from the Euronet database. An analysis of the number of children who show up in one of the more than 400 optician shops in Germany per month and present with an annual progression equal to or below $-0.5 D$ gives an indication of the myopia management need in Germany (Figure 3).^[11] This analysis revealed that per shop and per month on average 1 child at the age of 6 to 9 years, 2 to 3 at the age of 10 to 12 years and 3 at the age of 13 to 16 years present to the ECP who are in need of myopia management. These numbers highlight again that there are children also in Europe, who show progressive myopia and are in need of myopia management. On the other hand, the analysis also shows that the initial refraction, that is when children present to the ECP the very first time, is more and more myopic with increasing age. This indicates a need for a higher awareness and timely identification of children at risk for myopia progression at earlier ages.

In summary, combining the insights from the LIFE Child study, the analysis of the Euronet database and the scientific literature, the findings point to a trend of increasing myopia prevalence

in Europe – similar to what we see in North America, India and Australia, but to a much smaller extent than what is observed in East Asia. But still there are children also in Germany, in Europe, who show myopia progression and who are in need for myopia management.

ZEISS' commitment is thereby to follow the mandate from leading experts of the myopia research community and clinical practice, who clearly stated just at the International Myopia Conference that every diopter matters and every child counts.

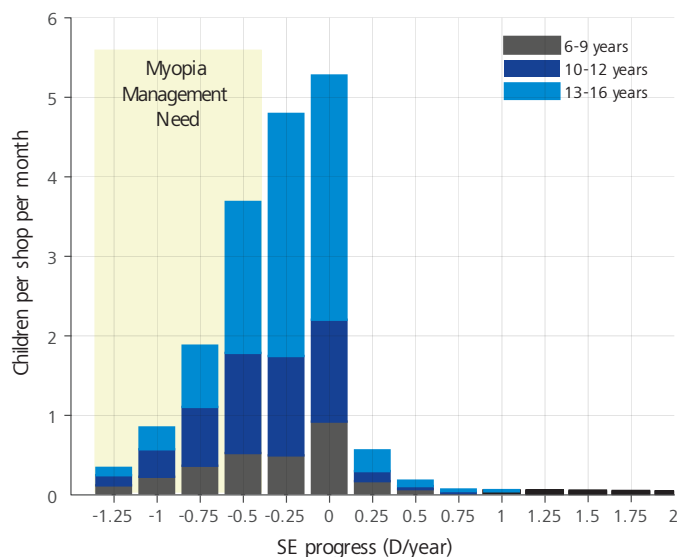

Figure 3. Number of children per shop per month who show an annual progression of $\leq -0.5D$ in Germany. Adapted from Barraza-Bernal et al. 2022.^[11]

Myopia Management: the science behind

Every diopter matters

The risk for visual complications in myopia is strongly related to axial length, refractive error, and age. Slowing down the eye growth, i.e., the axial elongation, and thereby reducing myopic refraction in adulthood is therefore the most important goal for the treatment of progressive myopia.^[12]

Looking at the risk to develop serious myopia-associated complications, research shows that in this case every diopter matters: a 1-diopter (D) increase in myopia is associated with a 57% increased risk for myopic maculopathy, 20% for open angle glaucoma, 21% for posterior subcapsular cataract, and 30% increased risk for retinal detachment.^[13] To name one example, slowing myopia progression by 1 D consequently should reduce the likelihood of a patient developing myopic maculopathy by 37%. Beyond -7.00 D, the observed linear trend with each increase in myopia diopters is even followed by an exponential trend in prevalence rates of pathologic myopia.^[14]

Because every diopter matters, children at risk deserve suitable interventions to prevent further myopization, mitigating the risk of high myopia and associated long-term health consequences.

Consolidated concepts on myopia progression from scientific research

It's evident that both, the early identification of the risk for developing myopia and the rate of progression in an individual are key for children to receive appropriate myopia interventions for controlling myopia development.

The individual progression rate of myopia depends on multiple factors, which are subject of intensive basic and clinical research. Although there are still controversies prevailing on the extent and causalities of some, the following were consistently identified as substantial risk factors for myopia development and/or progression^[15]:

- **Individual characteristics** including genetics, ethnicity, and gender
- **Lifestyle and environment**, including educational pressure with increased duration and intensity of education, time spent indoors, and near work activity

Focusing on lifestyle and environment as modifiable risk factors, a large body of evidence has been accumulated in recent years on their applicability for behavioral interventions.

By now, there exists plenty of consistent evidence on the protective effect of time outdoors – even though research to understand the underlying mechanisms is still on-going.^[15] If children spend 2 hours a day outdoors, this can provide significant protection from myopia. Increased time outdoors can even reduce the impact of known risk factors like parental myopia and higher levels of near work. While there is considerable evidence on the positive impact of increased time outdoors on delaying myopia onset, a recent meta-analysis gave evidence that it might also reduces myopia progression.

Likewise, the causal association between a higher prevalence and degree of myopia with an increasing intensity and duration of education emerged as a consistent finding from a large body of research.^[15] Again, the mechanisms involved mediating this association remain unclear. From early on, a high amount of reading and writing and overall, near work activities, was thereby discussed as a likely mediator of this relationship, leading to various hypotheses on the underlying mechanisms stimulating eye growth. From these, one of the main theories of myopia progression evolved: the peripheral defocus theory.

From peripheral defocus to simultaneous competing defocus

Refractive development and ocular growth are well known

to be regulated by visual feedback, mediated by local retinal mechanisms guiding the emmetropization of the juvenile, developing eye. Emmetropization is the developmental process that matches the eye's optical power to its axial length, so that the unaccommodated eye is focused on distance.^[16]

Visual signals originating in the macula, and more precisely the foveal region of the retina, are predominantly important for central high-acuity and color vision, but not essential for many vision-dependent aspects of ocular growth (Figure 1). The situation for peripheral regions of the retina, however, is different. As consequence out of anatomical structure and cellular physiology, the peripheral retina does not contribute to high-acuity vision but is assumed to play a major role in the refractive development of the eye. It is well established that signals originating in the peripheral retina have a substantial effect on axial elongation and refractive development for the foveal region of the retina.^[17]

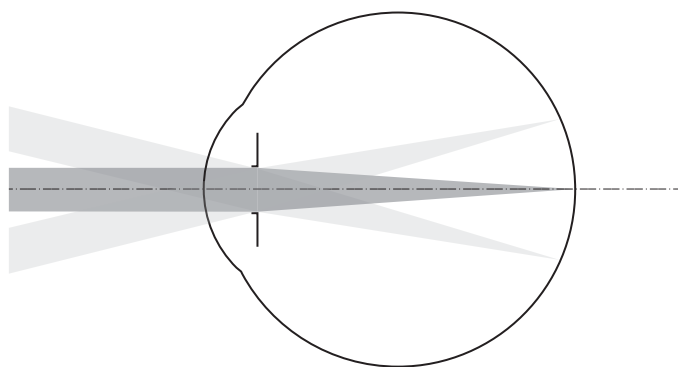

Figure 4. Foveal vision shown in dark grey is essential for high-acuity and color vision, while vision signals originating in the peripheral retina, shown in light grey, effectively regulate refractive development and axial elongation of the eye during the emmetropization process.

A compelling body of scientific evidence links perceived peripheral retinal blur, as a result of an imposed myopic or hyperopic defocus, to mechanisms modulating the intended emmetropization process of the developing eye. Investigated and validated in animal research and followed by human patient studies, consolidated evidence shows that an imposed hyperopic focus stimulates eye growth, while myopic defocus and its related blur on the peripheral retina implies a stop signal to slow down excessive axial elongation.^[18] This observation forms the basis of the so-called peripheral defocus theory.

In line with this theory, myopic children corrected with single vision lenses typically present with relative peripheral hyperopia with respect to axial refraction, while emmetropes and hyperopes show relative myopia in the periphery.^[18] Accordingly, the peripheral defocus theory suggests that to reduce the progression of myopia, it is of paramount importance to avoid hyperopic defocus and to ideally create a targeted myopic defocus in the retinal periphery, inhibiting further axial elongation by

interrupting the trigger of the visual feedback response for continued eye growth (Figure 3).

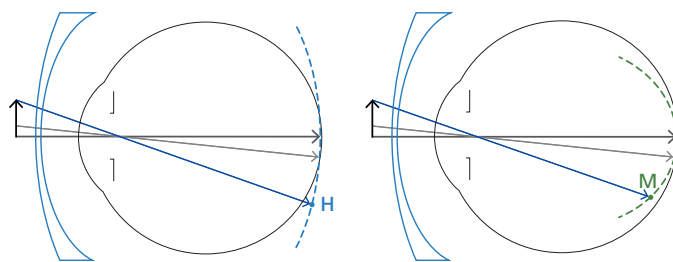

Figure 5. The mechanisms behind the peripheral defocus theory. Hyperopic retinal defocus (H) in the periphery caused by single-vision lenses may stimulate myopia development even in the presence of a focused foveal image. Application of peripheral myopic defocus (M) with an optimized lens design may slow the progression of myopia.

It is particularly interesting that when the eye experiences conflicting visual signals between the fovea and the periphery, peripheral vision dominates refractive development. If these visual signals expose the peripheral retina simultaneously to competing focal planes, refractive development typically targets the more anterior focal plane, thereby reducing the likelihood that the eye becomes myopic.^{[18], [19]} Scientific research suggests that simultaneous competing defocus inheres a stronger growth stop signal than continuous or homogeneous defocus.^[20] The evolution is served, from peripheral defocus to simultaneous competing defocus (Figure 5).

State-of-the-art optical interventions to correct & control myopia

For meaningful interventions on myopia progression, it is important to differentiate between myopia correction and myopia control. While single vision spectacle lenses and single vision contact lenses effectively correct the eye's refractive error, they do not provide any benefit in managing myopia progression. For myopia progression management, specifically tailored solutions are needed that provide a clinically meaningful benefit in slowing down axial elongation. In addition to the specific behavioral recommendations mentioned above, pharmacological and optical treatment strategies can be applied for myopia progression management. Optical treatments thereby offer the distinct advantage that they inherently provide both myopia correction and myopia control.

The induction of myopic defocus is thereby discussed as the key mechanism of a number of optical treatment strategies that have been shown to reduce myopia progression, including orthokeratology, soft multifocal contact lenses and myopia management spectacle lenses.

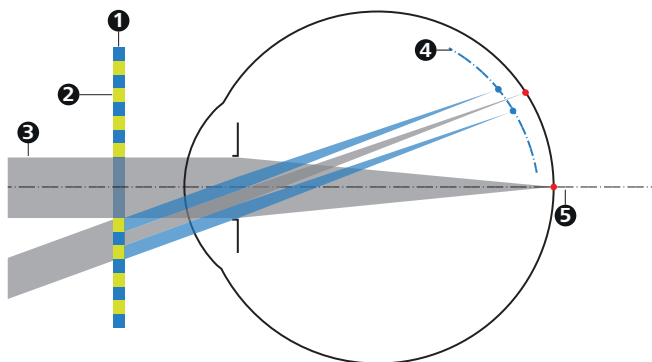

Figure 6. Simultaneous competing defocus theory in a nutshell: A single vision lens that provides clear vision in the central zone for far distance correction, while intermittent treatment zones that contain specific optical microstructures simultaneously induce a competing myopic defocus providing a stop signal to slow down myopia progression.

(1) Single vision lens, refractive correction zones in blue; (2) intermittent treatment zones; (3) far distance correction; (4) competing myopic defocus; (5) central clear vision.

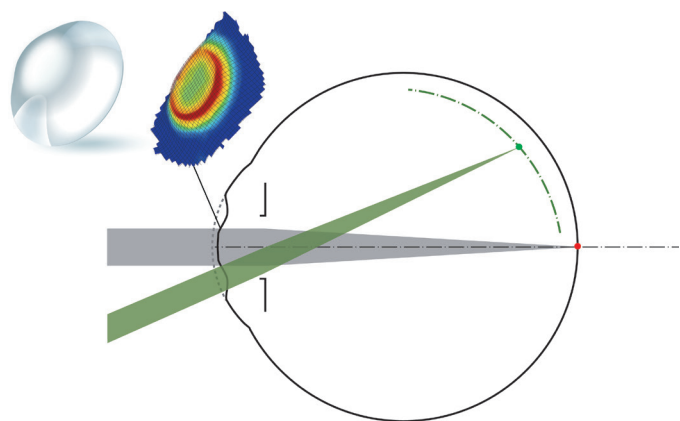

Figure 7. Schematic illustration of an ortho-k contact lens, the corneal topography and the ray path through the reshaped cornea following orthokeratology treatment. Light passing through the flattened central area of the cornea is focused on the fovea, while light passing through the steepened mid-peripheral cornea is focused on a point closer to the retina at the periphery, thereby increasing peripheral myopic defocus and decreasing relative peripheral hyperopia.

Orthokeratology (ortho-k) utilizes specially designed reverse-geometry corneal gas-permeable contact lenses that temporarily reshape the cornea through a redistribution of the multilayered corneal epithelium during overnight wear.^[18] Ortho-k thereby induces a flattening of the corneal center and steepening of the corneal mid-peripheral surface. The reshaped corneal surface topography is typically stable for at least one day. As a result, once the ortho-k contact lens is removed, one can observe its ring-like imprint on the cornea. As shown in Figure 7, light passing through the flattened central area of the cornea will be focused directly on the fovea, effectively correcting the eye's myopic refractive error, while light passing through the steepened mid-peripheral cornea will be focused on a point closer to the retina at the periphery, thereby increasing peripheral myopic defocus and decreasing relative peripheral hyperopia.^[21]

Daily disposable soft multifocal contact lenses pursue the same goal with center-distance designs that provide simultaneous correction for foveal vision and myopic defocus in the retinal periphery. This is for example achieved by applying concentric rings as distinct zones of alternating distance and relative addition power to produce two spheres of focus across the retina (Figure 8).

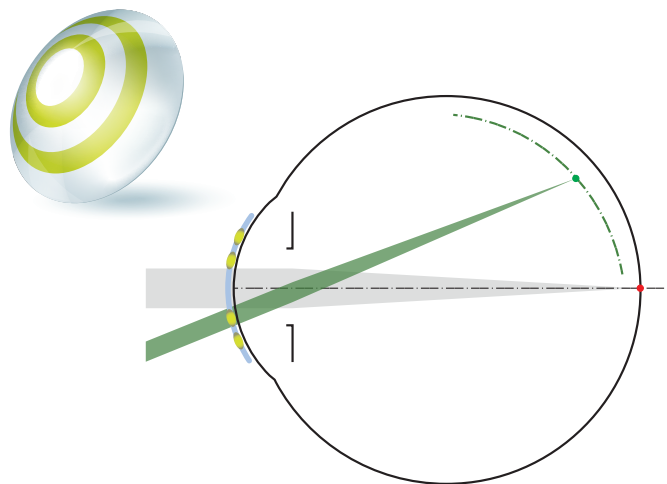

Figure 8. Schematic illustration of a soft multifocal contact lens and the ray path with soft multifocal contact lenses for myopia management providing simultaneous correction for foveal vision and myopic defocus in the retinal periphery through concentric rings as distinct zones of alternating distance and relative addition power.

Compared to contact lenses and ortho-k, spectacle lenses offer distinct advantages as intervention for myopia progression in children. They are easy to fit, affordable, mostly well accepted and tolerated, therefore most compliant, and minimally invasive. Based on the body of scientific evidence for simultaneous competing defocus as the most promising concept to slow down myopia progression, a new generation of spectacle lenses emerges. These lenses adopt optical microstructures with alternating defocus and correction zones, correcting myopia along the visual axis and simultaneously imposing relative myopic defocus over a large part of the retina for myopia progression management.

ZEISS MyoCare - a new lens category for myopia progression management

Building on more than two decades of basic and clinical research and the successful application of Myopia Management lens solutions in East Asia, in collaboration with Chinese optical experts including material and vision scientists, eye care practitioners and academics, ZEISS has developed a new lens category incorporating the concept of simultaneous competing defocus to address the pressing need for myopia progression management.

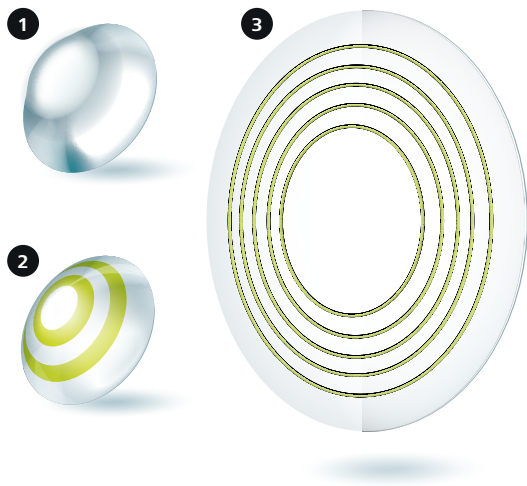

Figure 9. Ring-shaped structures as promising concept for myopia progression management, inspired by optical treatments with proven efficacy. Schematic illustration of (1) ortho-k contact lens, (2) soft multifocal contact lens, (3) ZEISS MyoCare.

The development was guided by evidence-based learnings from scientific concepts applied to optical interventions, to find the most promising path for a new lens design solution to correct and control progressive myopia. Looking at orthokeratology and soft multifocal contact lenses as established optical solutions with proven efficacy in myopia management, the ring-shaped imprints on the cornea following orthokeratology treatment, as well as the concentric rings of alternating power and correction zones applied in soft multifocal contact lenses, thereby offered the inspiration for a new lens design solution (Figure 9). In a joint effort together with a renowned institute in the field of myopia management, the Wenzhou Medical University Eye Hospital WMU, ZEISS developed and tested several design ideas and prototypes following this inspiration, leading to a new lens category for myopia progression management: ZEISS MyoCare.

Key considerations for new solutions, new challenges to overcome

The design of a new spectacle lens and in particular a spectacle lens solution for myopia progression management adopting the simultaneous competing defocus theory poses, by its very nature, major challenges that must be considered and appropriately addressed during its development.

First, in theory, there are many different possibilities how to combine a central clear zone for sharp vision with a functional zone incorporating distinct microstructures to provide myopia progression control. We know from scientific research that the impact of myopic defocus on refractive development decreases with eccentricity and is most potent in the near periphery closer to the fovea.^[19] At the same time, the dimension of the central clear zone needs to enable children to pursue their typical daily activities. As such, it is pivotal to find the optimal compromise:

a functional zone as large as possible, to allow and maximize simultaneous competing defocus across a large part of the retina, together with a central clear zone as small as possible, still ensuring practical sharp and clear vision for children’s main daily activities.

Second, while myopia progression control is of utmost importance, wearability is crucial to ensure the compliance and thereby the efficacy of any optical myopia management solution. Clinical outcomes from randomized controlled trials with spectacle lenses and contact lenses as well as animal research highlight the fact that wearing time is a contributing factor to the retardation of myopia progression, with increasing efficacy for increasing hours of daily wear.^{[22], [23]} A lens design for myopia management must therefore find a well-balanced solution to provide both effective myopia progression control and preserve good wearability.

Third, to ensure that the intended correction and myopic defocus is maintained for all gaze angles, it is important to consider the moving eye behind the spectacle lens. Additionally, and of particular importance for myopia management, myopic children that are corrected with typical single vision lenses are exposed to hyperopic defocus through optical aberrations in the lens periphery, which is a known trigger for axial elongation and further myopization. Accordingly, an optimal spectacle lens design for a myopia management solution must also aim to minimize the induction of unwanted hyperopic defocus.

ZEISS MyoCare – two pillars for myopia progression management

ZEISS MyoCare is based on two integral lens design concepts that form two complementary pillars for myopia progression management: C.A.R.E. Technology and ZEISS ClearFocus design (Figure 10).

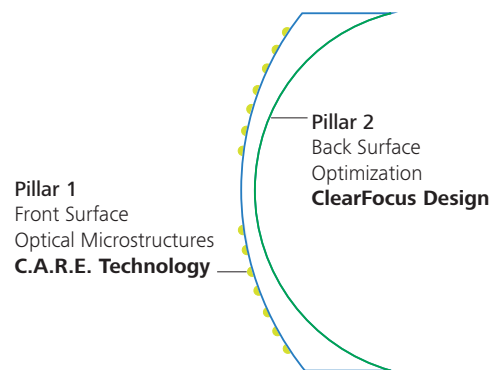

Figure 10. Two complementary pillars form the basis of ZEISS MyoCare lenses: (1) the cylindrical annular refractive elements (C.A.R.E.) Technology and (2) the ZEISS ClearFocus design.

Adopting the simultaneous competing myopic defocus theory, ZEISS MyoCare incorporates with the cylindrical annular refractive elements (C.A.R.E.) Technology optical microstructures

that deliver a “stop signal” to slow down excessive myopia progression. Myopia progression control and wearability of ZEISS MyoCare lenses is further supported by freeform back surface optimization, the ZEISS ClearFocus design, to optimally correct the eye’s refractive error for all viewing angles and to minimize unintended hyperopic defocus for oblique views through the lens periphery.

Cylindrical Annular Refractive Elements (C.A.R.E.) Technology – From idea to product

ZEISS MyoCare features a lens design consisting of a central clear zone for vision correction and a surrounding functional zone incorporating distinct microstructures as alternating segments of addition power elements. From a lens design perspective, there are a variety of theoretically possible options to optically introduce simultaneous defocus, leading to various concepts for microstructures within the functional zone (Figure 11). Beside its functional character for effective myopia management, it is however of equal importance to find a lens design solution that is wearable and that can be industrially produced.

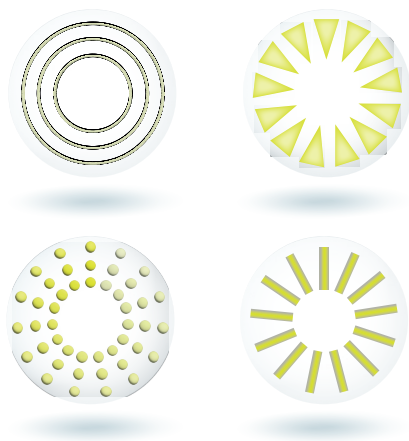

Figure 11. Schematic examples of different concepts for optical microstructures to be incorporated in the functional zone to provide simultaneous competing myopic defocus for myopia progression management.

Inspired by the ring-like imprints on the cornea following ortho-k treatment and motivated by the collaboration and early lens design ideas by Wenzhou Medical University Eye Hospital WMU, the microstructures incorporated in ZEISS MyoCare lenses are realized in a ring-shaped pattern as cylindrical annular refractive elements (C.A.R.E.). Surrounding the central clear zone, which provides the optimal refractive power to correct a patient’s myopic demand for clear and sharp vision for straight ahead view, the functional zone is expanding towards the periphery of the lens. The functional zone consists of alternating regular correction zones and C.A.R.E. elements that are so small in dimension that special optical methods are required to make them visible. Accordingly, the C.A.R.E. elements are hardly discernible with the naked eye, but can be visualized via light projection, as can be seen in Figure 12.

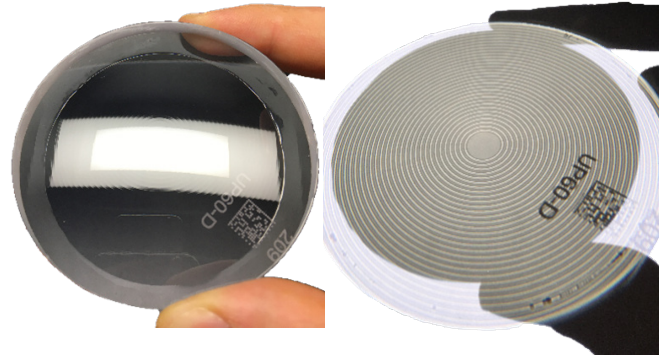

Figure 12. Photographs of ZEISS MyoCare lens in white light illumination. Left photo shows lens surface exhibiting the C.A.R.E. elements. Right photo showing light projection of microstructure C.A.R.E. elements in planar projection.

A more detailed visualization can be achieved by white light interferometry, a non-contact optical method for the three-dimensional characterization of a surface topography with a resolution down to the nanometer range. Figure 13 shows such a surface height measurement of a ZEISS MyoCare lens cut-out measured by white light interferometry. This measurement impressively shows the scale of the C.A.R.E. elements realized in the functional zone: while the distance between the C.A.R.E. elements is within the millimeter range; the height of the microstructures is in the micrometer range and thus about 1000 times smaller.

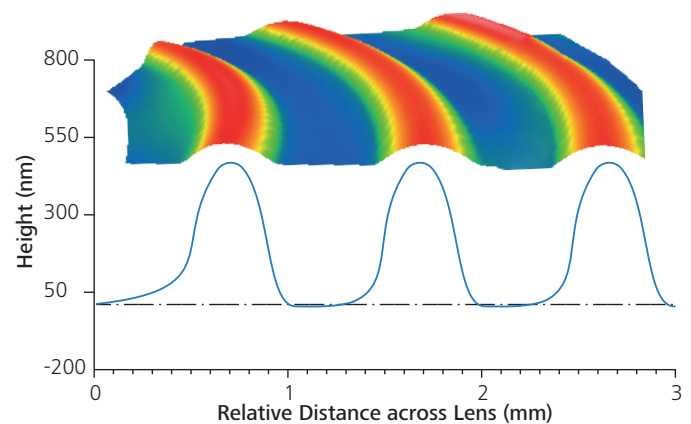

Figure 13. Color-coded height profile of a cut-out surface element of a ZEISS MyoCare lens measured by white light interferometry.

Please note the different scales for distance and height dimensions: the measurement shows an intra-structure distance in the millimeter range, while the height of the microstructures is in the nanometer range.

Optimization of C.A.R.E. Technology – finding the optimum balance between good vision and effective myopia management

The key to overcome the lens design challenges in finding the optimum balance between effective myopia progression control, clear vision to correct myopia and enable daily activities, all while preserving good wearability, is the specific dimension and interplay of distinct lens design optimization parameters (Figure 14), in particular:

- I. The size of the central clear zone
- II. The additional surface power of the cylindrical annular refractive elements, which is defined by the height and width of the microstructures
- III. The distance between two subsequent microstructure elements
- IV. The Fill Factor, describing the areal ratio of functional zone size that is occupied by the microstructures vs. the sections of regular lens power

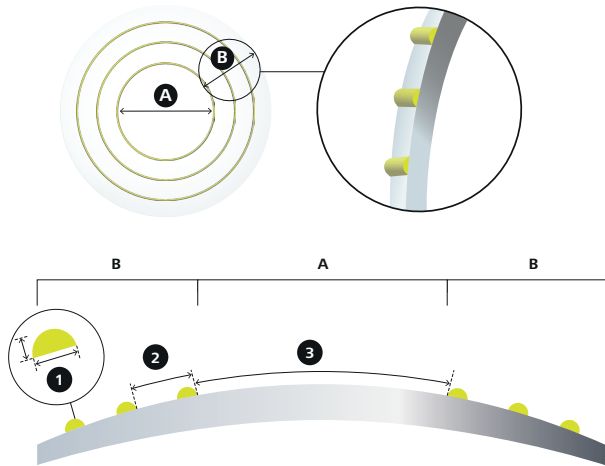

Figure 14. Schematic illustration of geometric lens optimization parameters for (A) the central clear zone and (B) the functional zone of ZEISS MyoCare lenses. (1) Height and width of cylindrical annular refractive elements, (2) distance between microstructures, (3) size of clear zone.

For the selection of the specific design of the C.A.R.E. Technology, more than a dozen prototypes with varying combinations of the outlaid optimization parameters were tested in a stepwise approach.

As a first step, the design candidates were assessed for subjective wearability. For this purpose, myopic test wearers graded the experience of blur for distance and near vision when looking through the central clear zone and the functional zone of the prototype lenses. Additionally, visual acuity was measured both when looking through the clear and the functional zone.

Based on the outcome of this first assessment, the lens design prototypes with the most promising evaluations were subjected to step two testing, a short-term wearer trial in a small cohort of Chinese children to assess the wearability of the prototypes in real-life. The children wore the test lenses for several days in their daily life. Again, wearability and visual acuity was assessed to evaluate the subjective visual performance of the lens designs.

This evaluation allowed ZEISS lens design and vision experts to select the prototypes that offered the optimal combination of vision correction, wearability, adaptation, plus highest ratings for satisfaction after several days of wear. Two lens design variants, MyoCare S and MyoCare representing a softer and a harder version of the ZEISS MyoCare lens design, thereby emerged as two promising candidates with likewise good evaluations.

Both lens design variants are now subjected to a multi-center randomized controlled 2-year clinical trial to assess their safety and effectiveness as myopia management solution.

Size of the central clear zone

Myopia management lens design and geometries always represent a balance between i) the desired treatment effect of delivering a stop signal towards the excessive eye growth and ii) wearability and compliance of the patient to wear the lenses. In particular, the clear zone size in the center of the lens must be suitable for stressless binocular vision during daily routines like school lectures. Also, the binocular near vision zone must support reading development, covering a suitable and unobstructed word span visibility. According to lens design simulations, a central clear zone of 7 mm to 9 mm seems to be optimal to allow for the desired visual performance.

With a 9 mm diameter of the clear zone for MyoCare S and a 7 mm diameter for MyoCare, ZEISS MyoCare lenses ensure sharp vision with an optimal distance correction. The clear zone provides enough space to enable children to pursue their typical daily activities without any accommodation issues during near tasks like reading or writing. At the same time, ZEISS follows the latest insights from scientific research on the location-specific

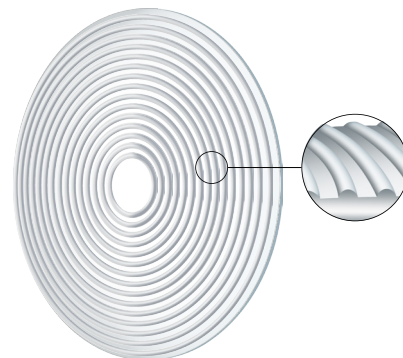

Figure 15. ZEISS MyoCare lenses target a fill factor of 0.5, describing the areal ratio of functional zone size that is occupied by the C.A.R.E. cylinder elements vs. the sections of regular lens power. the height of the microstructures is in the nanometer range.

impact of myopic defocus^[19], keeping the clear zone as small as possible in order to establish an effective functional zone projecting myopic defocus on the near periphery close to the fovea.

Fill Factor, the key to preserve wearability

ZEISS MyoCare lenses feature a functional zone that consists of alternating cylindrical annular refractive elements (C.A.R.E.) and intermediate spaces of regular single vision correction optimized for far vision refraction. The way to manage the location and alternation of both, the correction and functional addition elements through the entire front lens surface, surrounding the central clear zone, is key to preserve wearability. The ratio between these two elements within the functional zone is described by the so-called fill factor, i.e., the areal ratio of

functional zone size that is occupied by the C.A.R.E. cylinder elements vs. the sections of regular lens power. The fill factor of any alternating microstructure geometry can be determined and compared by calculating the ratio within a defined reference area, i.e., a circle as shown in Figure 15. Based on the outcome of extensive prototype testing, ZEISS MyoCare lenses target a fill factor of 0.5, representing a balanced distribution of defocusing elements and correction sections within the functional zone.

Mean additional surface power of cylindrical annular refractive elements

Empirical evidence shows that the additionally introduced myopic defocus should be in the range between +1.5 D and +5 D for effective myopia progression management. If the amount of myopic defocus is less, effectiveness seems to be reduced. In an ophthalmic lens, the amount of induced myopic defocus is directly related to the additional surface power of the microstructure elements incorporated in the lens design.

Inspired by the ring-like imprints on the cornea following ortho-k treatment, the microstructures incorporated in ZEISS MyoCare lenses are realized in a ring-shaped pattern as cylindrical annular refractive elements (C.A.R.E). For the evaluation of the effective mean additional surface power, it is thereby important to consider that the calculation of the addition power of a cylindrical lens differs inherently from the mean additional surface power of a spherical structure. For spherical structures, the mean additional surface power is determined by the radius of the curvature of the structure (**R**) and the refractive index of the lens material (**n**). For a structure that is formed as a cylinder the situation is different, because a cylinder presents two different main powers along two meridians with an angle alpha representing the orientation of the meridian. For alpha = 0° (or 180°), the meridian is aligned with the axial axis of the structure, for alpha = 90° (or 270°) the meridian orientation is perpendicular to the axial axis and therefore represents the radial axis.

For the meridian along the axis with alpha = 0° (or 180°), the structure has no curvature or put differently, a curvature radius of infinity and thus a power of zero. For the perpendicular orientation of alpha = 90° (or 270°) along the radial axis, the curvature is maximal and thus the power is maximal as well. In a generalized formula for arbitrary orientations of the meridian with the angle alpha, the angular power P(alpha) is determined by the curvature radius R and the material index n based on the following formula:

$$P(\alpha) = \frac{(n - 1)}{R} \cdot \sin^2 \alpha = P_{max} \cdot \sin^2 \alpha$$

The mean additional surface power of the cylinder structure is the average of P(alpha) along alpha, thus:

$$P_{structure} = P_{max} / 2$$

For MyoCare S, the cylindrical microstructures inhere a nominal dioptric power of +7.6 D along the radial axis, which translates, following the described equation, into a mean additional surface power of +3.8 D to induce the intended relative myopic defocus (Figure 13). For MyoCare, the cylindrical microstructures inhere a nominal power of +9.2 D, translating into a mean additional surface power of +4.6 D (Figure 16).

C.A.R.E. Technology – From geometry to optical function

As can be seen in Figure 16, the path of a beam of light after transmission through a cylinder is not trivial. Some portions of the light beam undergo refraction from the above-mentioned radial power component, whereas other portions are at the same time refracted by the axial power component. While Figure 16 shows a simplified drawing for light bundles in a perpendicular incidence to the radial and axial cylinder axis, the result of both cylinder refraction powers becomes even more complicated for oblique angles of incidence. The complex shape and form of the refracted light beam can be best described

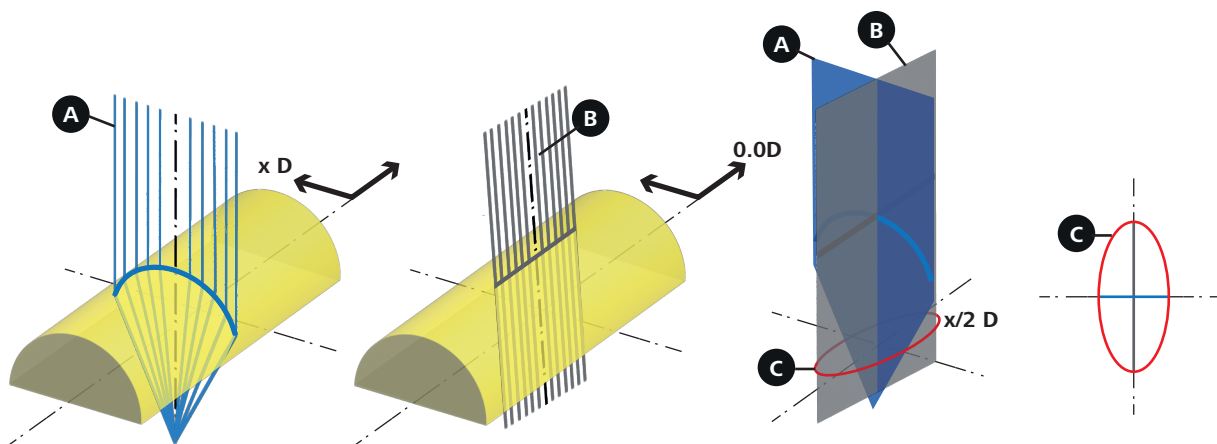

Figure 16. Composition of the mean additional surface power of ZEISS MyoCare lenses. (A) Cylindrical annular refractive elements (C.A.R.E) are produced with a nominal power of x D along the radial axis and (B) a power of zero (0 D) along the axial axis which (C) together induces a caustic distribution of relative myopic defocus with a mean additional surface power of x/2 D.

by the term of an optical caustic. A caustic is defined as the envelope of light rays that have been reflected or refracted from a curved optical surface. A caustic is thereby a holistic property of a bundle of rays, not inherent in any individual ray. As the light bundle passes through the refractive material, it gets focused and diverted, creating captivating light patterns of varying light intensity. Even though they are hardly known and mostly described as unintentional side effects of light refraction, optical caustics are omnipresent in our daily lives. One of the most common examples are the complex patterns of light on the surface of a swimming pool, the projection of sunlight onto the bottom of shallow waters, or light passing through a glass of clear water onto a tabletop (Figure 17).



Figure 17. Optical caustics are omnipresent in everyday life, for example in the light pattern that appears on a tabletop when light passes through a glass of water. In contrast to these random light patterns that are evident in nature and everyday life, it is possible to control caustic light patterns by optimizing the geometry of a refractive surface. With appropriate changes in the surface geometry, light can be redirected to form almost any desired caustic shape. In the case of ZEISS MyoCare lenses, this light refraction phenomenon is applied to induce the intended distribution of defocus in the myopic space following the theory of simultaneous competing myopic defocus for myopia management.

As represented in Figure 18, light bundles passing through the C.A.R.E. elements of a ZEISS MyoCare lens are not refracted within an ideal and single focus point but intentionally form a caustic with an extended focus range that converges to a minimal waist and diverges again. The caustic thereby creates a blended distribution of myopic defocus in front of the retina.

ZEISS ClearFocus design – meeting the challenge of the moving eye

In contrast to a contact lens, where the optical correction moves along with the eye, and orthokeratology, where the cornea itself is temporarily reshaped to provide the intended optical correction and myopia control stimulus, spectacle lenses must

consider the moving eye behind the lens to ensure that the intended correction and myopic defocus is maintained for all gaze angles.

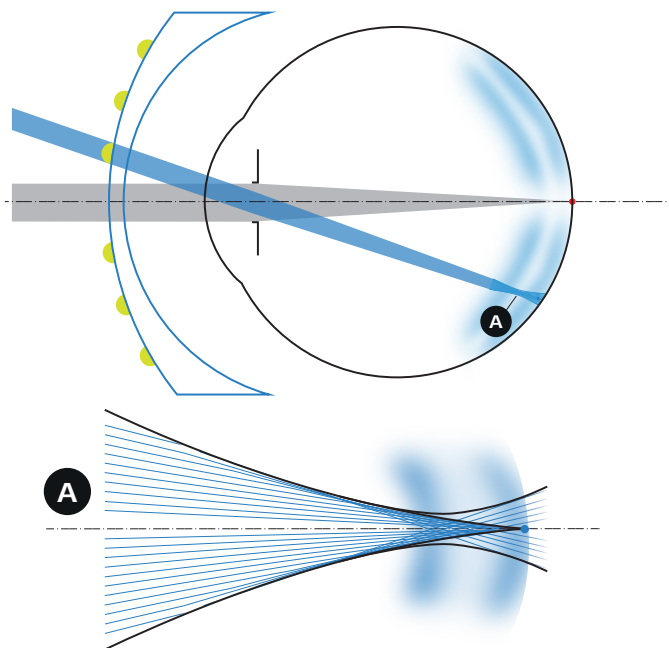

Figure 18. Due to their specific surface geometry, light passing through the C.A.R.E. elements of ZEISS MyoCare lenses is not refracted in a single focus point but forms a caustic that creates a blended distribution of myopic defocus in front of the retina.

Typical spherical single vision lenses offer only poor optical performance particularly for gaze directions away from the lens center. As a consequence, unwanted optical aberrations introduce a deterioration of the actual refraction from the intended optimal correction in the lens periphery. For ZEISS MyoCare, such optical aberrations would result not only in a compromised refractive correction but on top in a reduction of the intended myopic defocus from the cylindrical annular refractive elements in the functional zone. Additionally, and of particular importance for myopia management, with typical

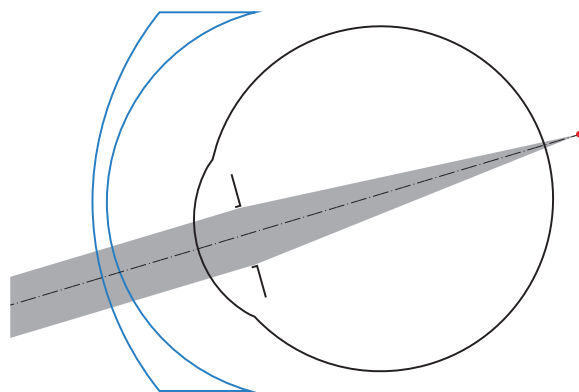

Figure 19. Myopic children corrected with typical spherical single vision lenses are exposed to hyperopic defocus through unwanted optical aberrations in the periphery of the lens.

spherical single vision lenses, myopic children are exposed to hyperopic defocus introduced by the optical aberrations in the lens periphery (Figure 19). Hyperopic defocus is a known trigger for axial elongation and further myopization.

The reason for the poor optical performance in the lens periphery of typical spherical single vision lenses lies in the lens design itself: a better optical performance can only be achieved by applying a higher complexity to the lens design optimization. Therefore, ZEISS MyoCare inherits a point-by-point optimization for its non-spherical back surface design, the so-called ZEISS ClearFocus design.

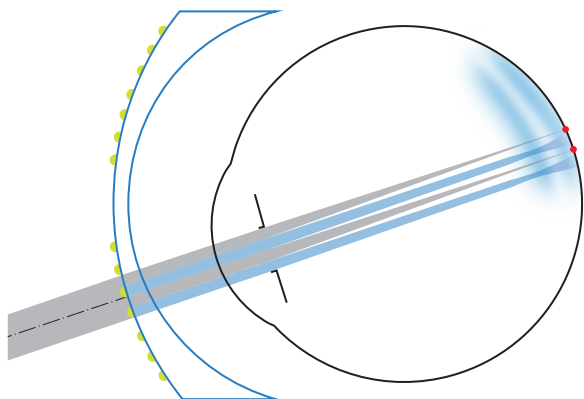

Figure 20. ZEISS MyoCare features with ZEISS ClearFocus design a point-by-point optimization of the back surface to ensure that the optimal refractive correction and the intended myopic defocus are maintained for all gaze angles.

With ZEISS ClearFocus design, both the optimal refractive correction according to the patient's myopic refractive demand and the intended myopic defocus are maintained for all gaze directions (Figure 20). This is of particular interest not only for distinct viewing behaviors through the central clear zone when pursuing a focused task, but also for unintended gazes and saccades to the lens periphery.

In addition to that, ZEISS ClearFocus design effectively minimizes the induction of hyperopic defocus as opposed to typical spherical single vision lenses. This can be easily seen in a comparative mathematical simulation of two such lenses. The mathematical model is based on a realistic base lens design as used in real life, exhibiting standard base curve, diameter, and suitable refraction values. As criterion of comparison, the spherical error induced by the individual lenses at any given point of gaze angle and orientation along the complete diameter of the lens is analyzed.

Figures 21 and 22 show a representative example of this analysis for the comparison of spherical single vision lenses and ZEISS MyoCare lenses with -2 D and -4 D refractive lens power. Positive values in spherical error, representing an induced myopic defocus, are thereby depicted in blue and negative values in spherical error, representing an induced hyperopic shift, are depicted in red.

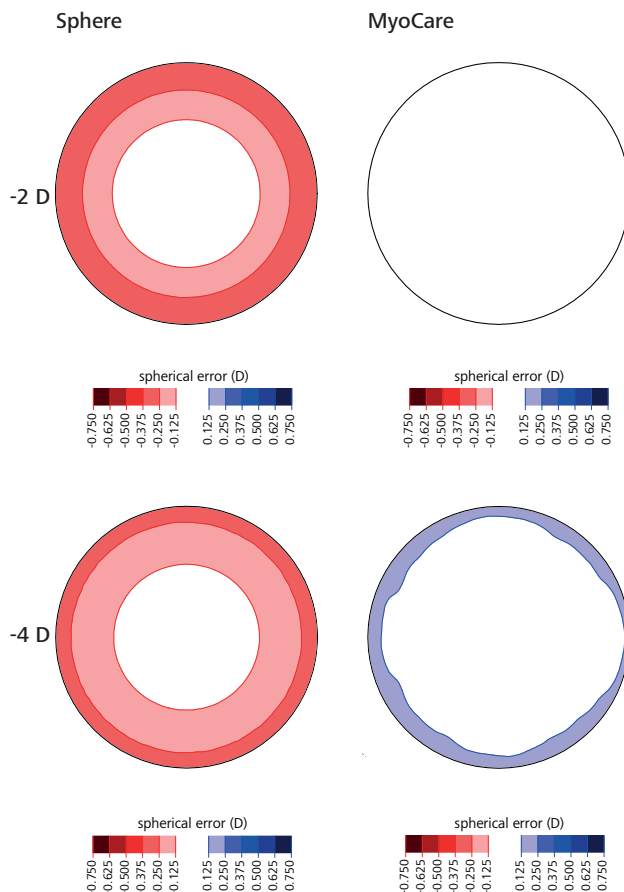

Figure 21. Spherical errors in typical standard single vision lenses induce hyperopic defocus (shown in red) for gazes through the lens periphery. ZEISS MyoCare lenses feature with ZEISS ClearFocus design an optimized back surface, effectively preventing the induction of hyperopic defocus.

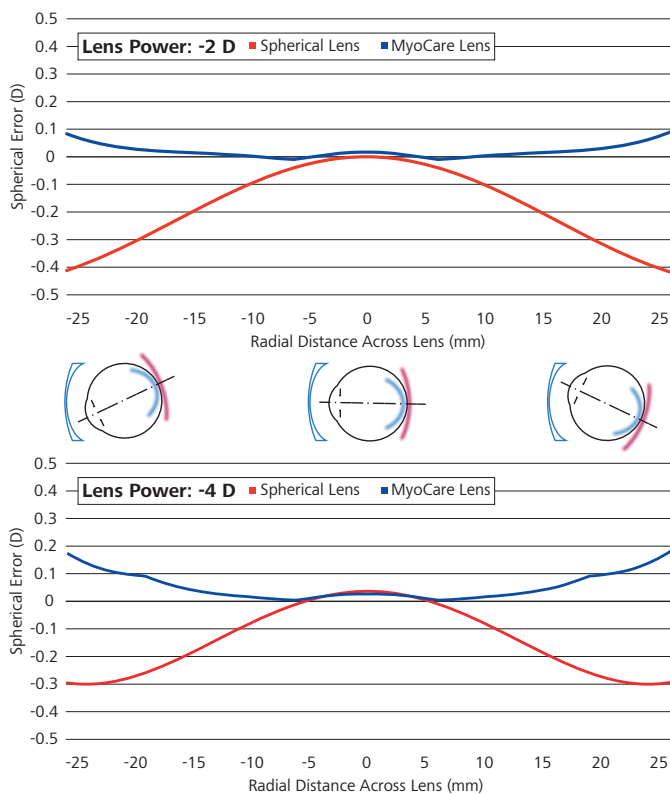

Figure 22. Optical aberrations in typical spherical single vision lenses lead to spherical errors inducing hyperopic defocus with increasing radial distance from the lens center. With ZEISS ClearFocus design, ZEISS MyoCare's back surface avoids unwanted hyperopic defocus for all gaze angles.

While the difference and amount of the induced spherical error is, as expected, minimal for both lenses in the lens center, representing straight view through the lens, the situation is changing with increasing distance from the center in all directions.

As shown in Figure 22, for spherical single vision lenses, already at about 10 mm distance from the lens center, the spherical error becomes obvious, with increasing negative power towards the outer lens perimeter, thereby inducing hyperopic defocus. In contrast to the spherical lens design, ZEISS MyoCare lenses exhibit a flat and almost invariant spherical error throughout the lens, ensuring the focus to remain close to the intended focus shell, i.e., close to the retina. With increasing eccentricity from the lens center, the spherical error is even growing slightly more positive, inducing relative myopic defocus. In sum, ZEISS ClearFocus design in ZEISS MyoCare lenses effectively minimizes unwanted hyperopic defocus for all viewing angles.

Summary

Inspired by the ring-like imprints on the cornea following orthokeratology treatment, the design of ZEISS MyoCare adopts with its C.A.R.E. Technology annular cylindrical refractive elements to induce simultaneous competing myopic blur on the peripheral retina to slow down myopia progression. The patented Cylindrical Annular Refractive Elements (C.A.R.E.) Technology incorporates alternating defocus and correction zones expanding towards the periphery of the lens. The design is focused on myopia progression control, while preserving wearability.

Eyes are constantly moving and therefore ZEISS MyoCare lenses feature with the ZEISS ClearFocus design an optimized back surface, not only providing the correct lens power but minimizing unwanted hyperopic defocus independent of gaze direction. This together ensures good vision and intended myopia management for all viewing angles.

Two lens design variants of ZEISS MyoCare lenses are currently being tested in on-going multicenter clinical trials with leading medical institutes and hospitals across China and in Europe to ensure a comprehensive, representative, and robust evaluation of the safety and effectiveness of ZEISS MyoCare lenses.

References

- [1] Németh J, Tapasztó B, Aclimandos WA, et al. Update and guidance on management of myopia. *European Society of Ophthalmology in cooperation with International Myopia Institute. Eur J Ophthalmol.* 2021;31(3):853-883. doi: 10.1177/1120672121998960.
- [2] Chen M, Wu A, Zhang L, et al. The increasing prevalence of myopia and high myopia among high school students in Fenghua city, eastern China: a 15-year population-based survey. *BMC Ophthalmol.* 2018;18(1):159. doi: 10.1186/s12886-018-0829-8.
- [3] Holden BA, Fricke TR, Wilson DA, et al. Global Prevalence of Myopia and High Myopia and Temporal Trends from 2000 through 2050. *Ophthalmology.* 2016;123(5):1036-42. doi: 10.1016/j.ophtha.2016.01.006.
- [4] Brandt M, Meigen C, Trukenbrod C, et al. Refraktionsstatus in einer deutschen pädiatrischen Kohorte: Eine Querschnittsanalyse der LIFE Child-Daten. *Optometry & Contact Lenses.* 2021;1(1):6-13. doi:10.54352/dozv.HISM2127
- [5] Literature review on myopia prevalence among children in Europe Sources: Alvarez-Peregrina et al., 2021; Brandt et al., 2021; Czepita et al., 2007; Klaver et al., 2022; Lundberg et al., 2017; Matamoros et al., 2015; McCullough et al., 2016.
- [6] Williams KM, Bertelsen G, Cumberland P, et al; European Eye Epidemiology (E3) Consortium. Increasing Prevalence of Myopia in Europe and the Impact of Education. *Ophthalmology.* 2015;122(7):1489-97. doi: 10.1016/j.ophtha.2015.03.018.
- [7] Sankaridurg P, Tahhan N, Kandel H, et al. IMI Impact of myopia. *Invest Ophthalmol Vis Sci.* 021;62(5):2. doi: 10.1167/iov.62.5.2.
- [8] Trukenbrod C, Meigen C, Brandt M, Vogel M, Wahl S, Jurkatut A, et al. Reference curves for refraction in a German cohort of healthy children and adolescents. *PLoS ONE.* 2020;15(3): e0230291. doi: 10.1371/journal.pone.0230291.
- [9] Trukenbrod C, Meigen C, Brandt M, Vogel M, Sanz Diez P, Wahl S, Jurkatut A, Kiess W. Longitudinal analysis of axial length growth in a German cohort of healthy children and adolescents. *Ophthalmic Physiol Opt.* 2021;41:532-540. doi: 10.1111/opo.12817.
- [10] Tideman JW, Polling JR, Vingerling JR, et al. Axial length growth and the risk of developing myopia in European children. *Acta Ophthalmol.* 2018 May;96(3):301-309. doi: 10.1111/aos.13603.
- [11] Barraza-Bernal MJ, Ohlendorf A, Sanz Diez P, Wahl S, Kratzer T. (2022, September 4-7). Myopia management need in Germany [Poster Presentation]. *International Myopia Conference, Rotterdam, NL.*
- [12] Klaver C, Polling JR; Erasmus Myopia Research Group. Myopia management in the Netherlands. *Ophthalmic Physiol Opt.* 2020 Mar;40(2):230-240. doi: 10.1111/opo.12676.
- [13] Bullimore MA, Ritchey ER, Shah S, Leveziel N, Bourne RRA, Flitcroft DI. The Risks and Benefits of Myopia Control. *Ophthalmology.* 2021;128(11):1561-1579.
- [14] Verkharla PK, Ohno-Matsui K, Saw SM. Current and predicted demographics of high myopia and an update of its associated pathological changes. *Ophthalmic Physiol Opt.* 2015;35:465-475.
- [15] Morgan IG, Wu PC, Ostrin LA, Tideman JW, Yam JC, Lan W, Baraas RC, He X, Sankaridurg P, Saw SM, French AN, Rose KA, Guggenheim JA. IMI Risk Factors for Myopia. *Invest Ophthalmol Vis Sci.* 2021;62(5):3.
- [16] Troilo D, Smith EL 3rd, Nickla DL, Ashby R, Tkatchenko AV, Ostrin LA, Gawne TJ, Pardue MT, Summers JA, Kee CS, Schroedl F, Wahl S, Jones L. IMI - Report on Experimental Models of Emmetropization and Myopia. *Invest Ophthalmol Vis Sci.* 2019;60(3):M31-M88.
- [17] Smith Iii EL, Arumugam B, Hung LF, She Z, Beach K, Sankaridurg P. Eccentricity-dependent effects of simultaneous competing defocus on emmetropization in infant rhesus monkeys. *Vision Res.* 2020;177:32-40.
- [18] Jonas JB, Ang M, Cho P, Guggenheim JA, He MG, Jong M, Logan NS, Liu M, Morgan I, Ohno-Matsui K, Pärssinen O, Resnikoff S, Sankaridurg P, Saw SM, Smith EL 3rd, Tan DTH, Walline JJ, Wildsoet CF, Wu PC, Zhu X, Wolffsohn JS. IMI Prevention of Myopia and Its Progression. *Invest Ophthalmol Vis Sci.* 2021;62(5):6.
- [19] Smith Iii EL, Arumugam B, Hung LF, She Z, Beach K, Sankaridurg P. Eccentricity-dependent effects of simultaneous competing defocus on emmetropization in infant rhesus monkeys. *Vision Res.* 2020;177:32-40.
- [20] Smith Iii EL. Optical treatment strategies to slow myopia progression: effects of the visual extent of the optical treatment zone. *Exp Eye Res.* 2013;114:77-88.
- [21] Kakita T, Hiraoka T, Oshika T. Influence of overnight orthokeratology on axial elongation in childhood myopia. *Invest Ophthalmol Vis Sci.* 2011;52:2170-2174.
- [22] Lam CS, Tang WC, Tse DY, Tang YY, To CH. Defocus Incorporated Soft Contact (DISC) lens slows myopia progression in Hong Kong Chinese schoolchildren: a 2-year randomised clinical trial. *The British Journal of Ophthalmology.* 2014;98(1):40-45.
- [23] Zhu X, Wallman J. Temporal properties of compensation for positive and negative spectacle lenses in chicks. *Invest Ophthalmol Vis Sci.* 2009;50:37-46.
- [24] Liu X, Wang P, Xie Z, Chen M, Sun M, Wang J, Huang J, Wang Y, Chen S, Chen Z, Li Y, Qu J, Mao X. One-year myopia control efficacy of cylinder incorporated annular segments (CIAS) spectacle lenses. *Unpublished data. Manuscript submitted for publication.*