



Use Zone: 35' x 22'



Fall Height: 4 Feet



ADA Access: Yes



Age Group: 2-12



Occupancy: 20-24



Free Shipping!

COMPONENTS: Floating Tunnel Tower / Frog Pad Challenge Ladder / Ring Swing Challenge Ladder / Cylinder Spinner / Boulder Climber / Single Sectional Slide / Cargo Climber / Climber / Climber / Crab Pods / Saddle Slide / Cylinder Spinner



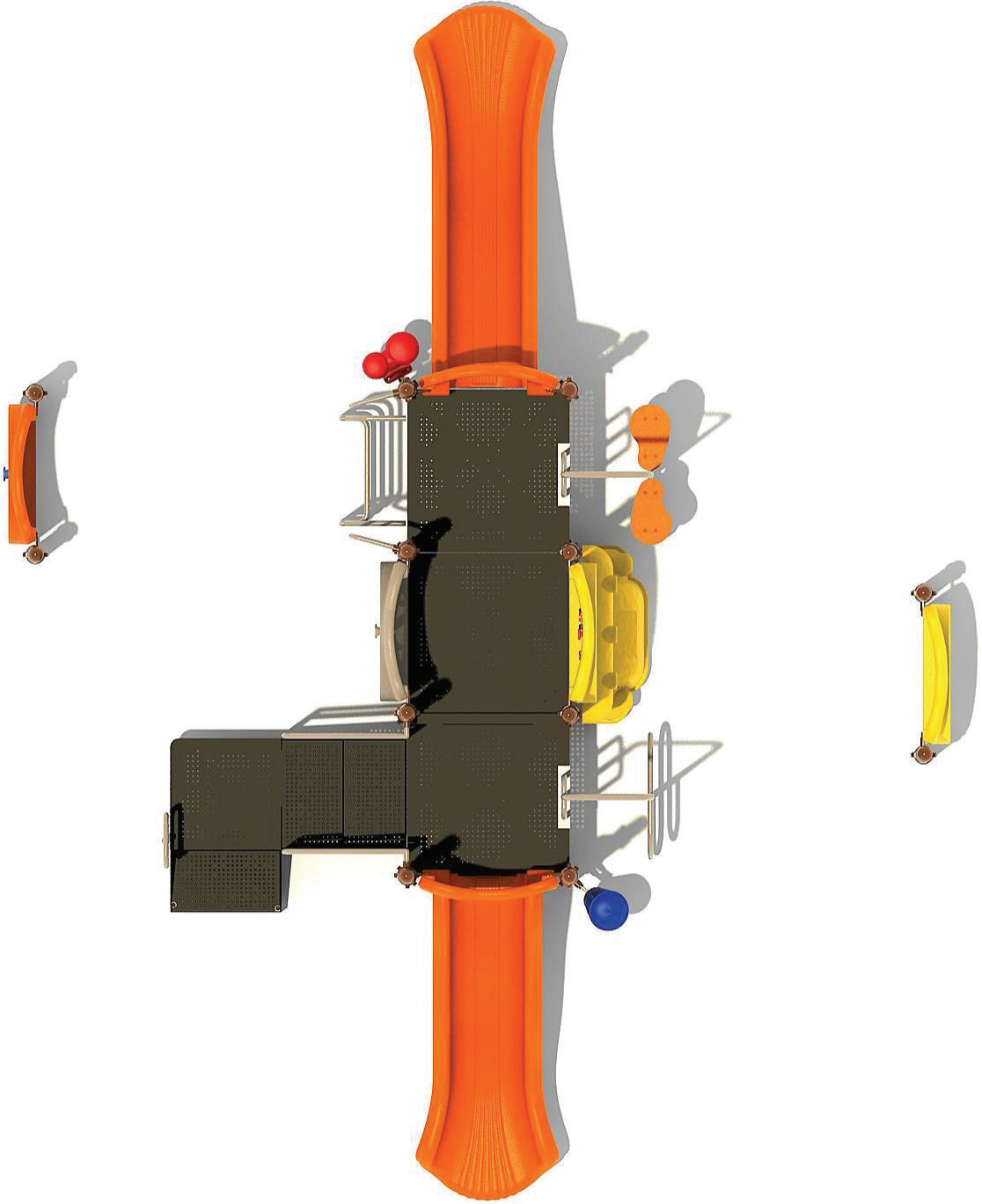

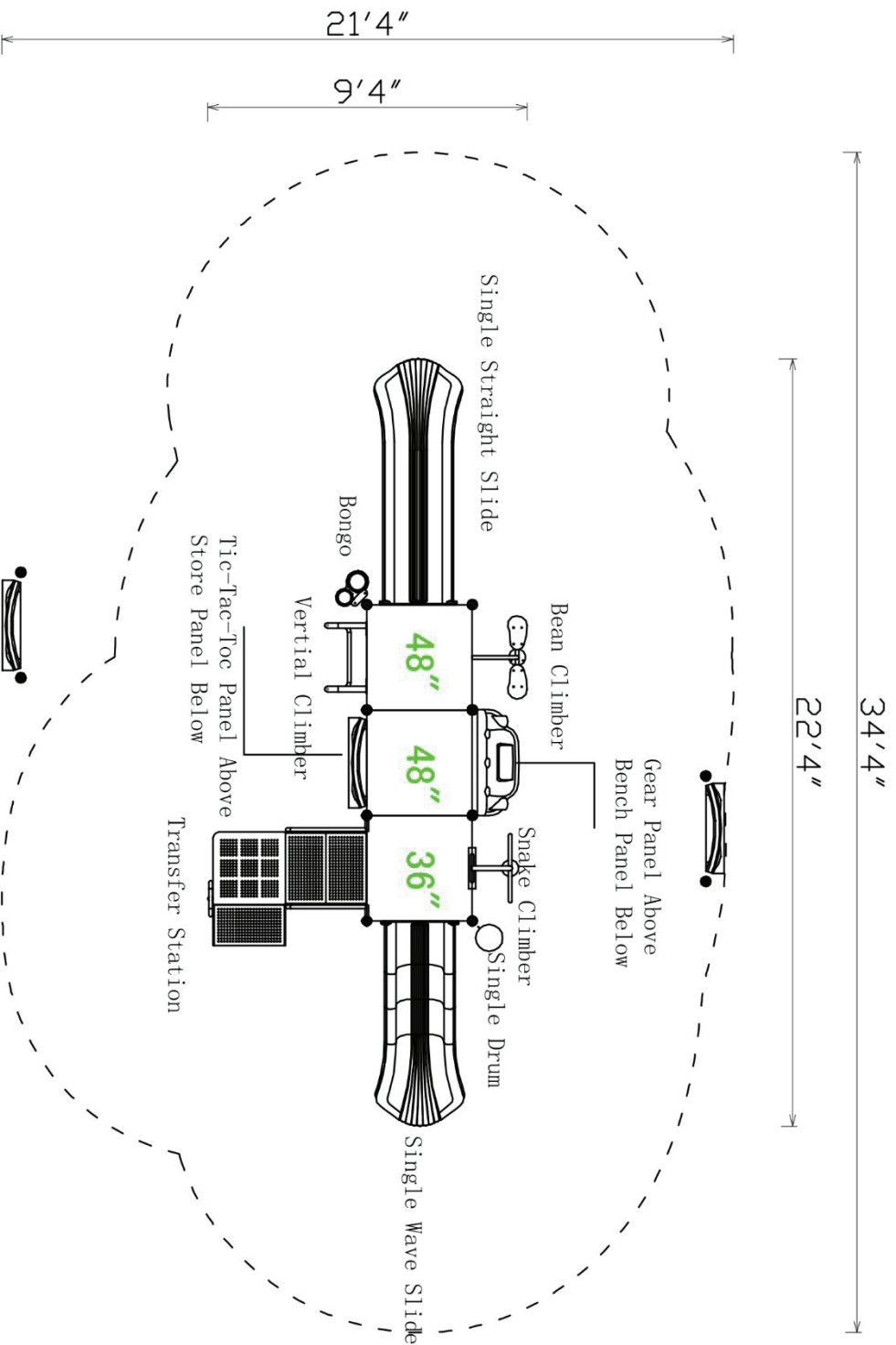

Notes:

This play structure design meets ADA accessibility guidelines established in ASTM-1487 and CPSC guidelines. All playground equipment should be installed over ADA accessible safety surfacing

Deck Height: 48"

Structure Size: 22'4"x 9'4"x 10'

Use Zone: 34'4"x 21'4"

Surface Area: 736 sq ft

Child Capacity: 20-24

Age Range: 2-12

Post Diameter: 3.5"

Weight: 1300 LBS

Color Information:

Posts: Brown Metal Rails: Tan

Decks: Brown Roofs: None

Slides: Orange

Panels: Orange/Yellow/Tan