



Use Zone: 39' x 30'



ADA Access: Yes



Fall Height: 5 Feet



Age Group: 2-12



Occupancy: 28-32



Free Shipping!

**COMPONENTS:** Floating Tunnel Tower / Frog Pad Challenge Ladder / Ring Swing Challenge Ladder / Cylinder Spinner / Boulder Climber / Single Sectional Slide / Cargo Climber / Climber / Climber / Crab Pods / Saddle Slide / Cylinder Spinner

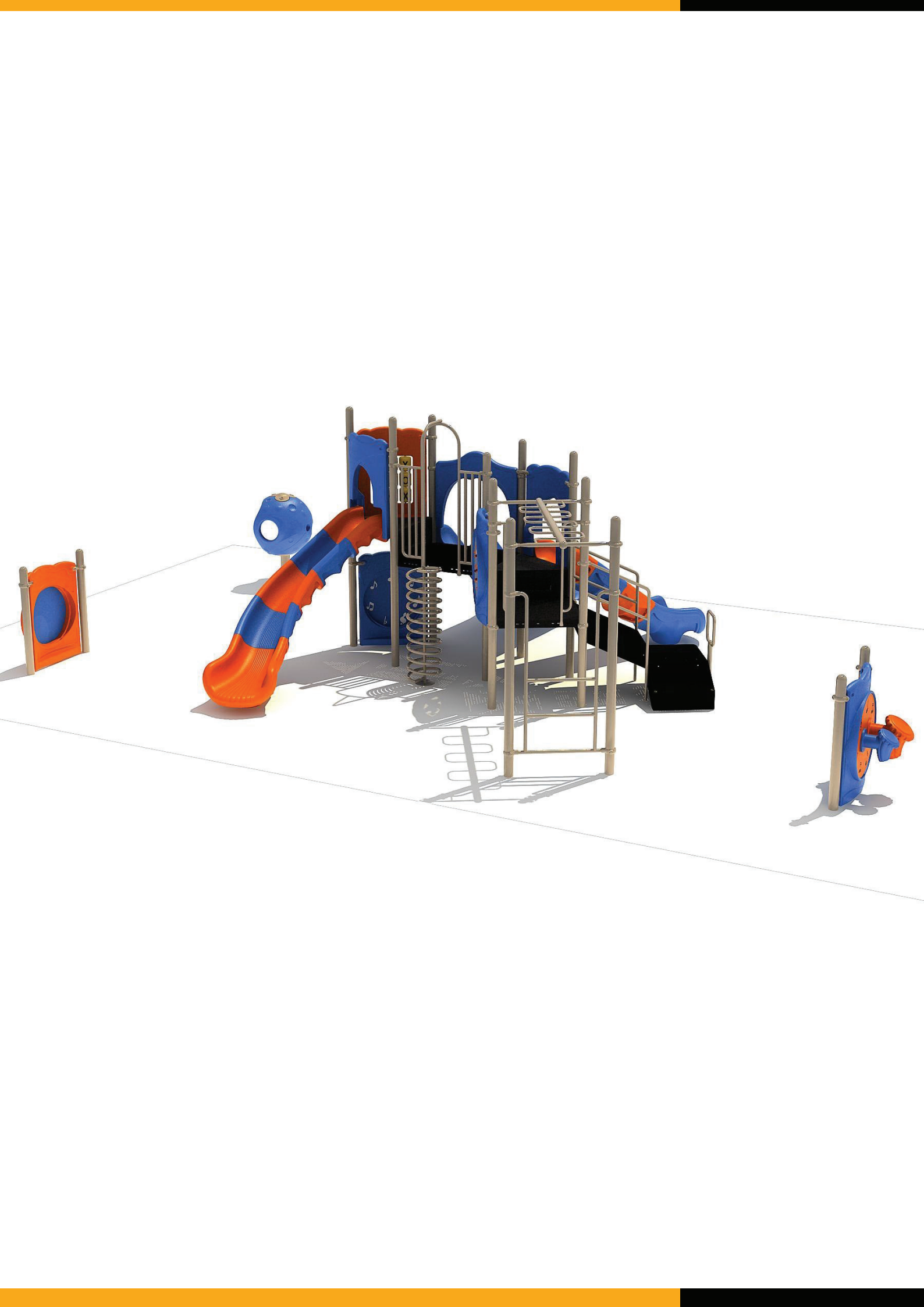



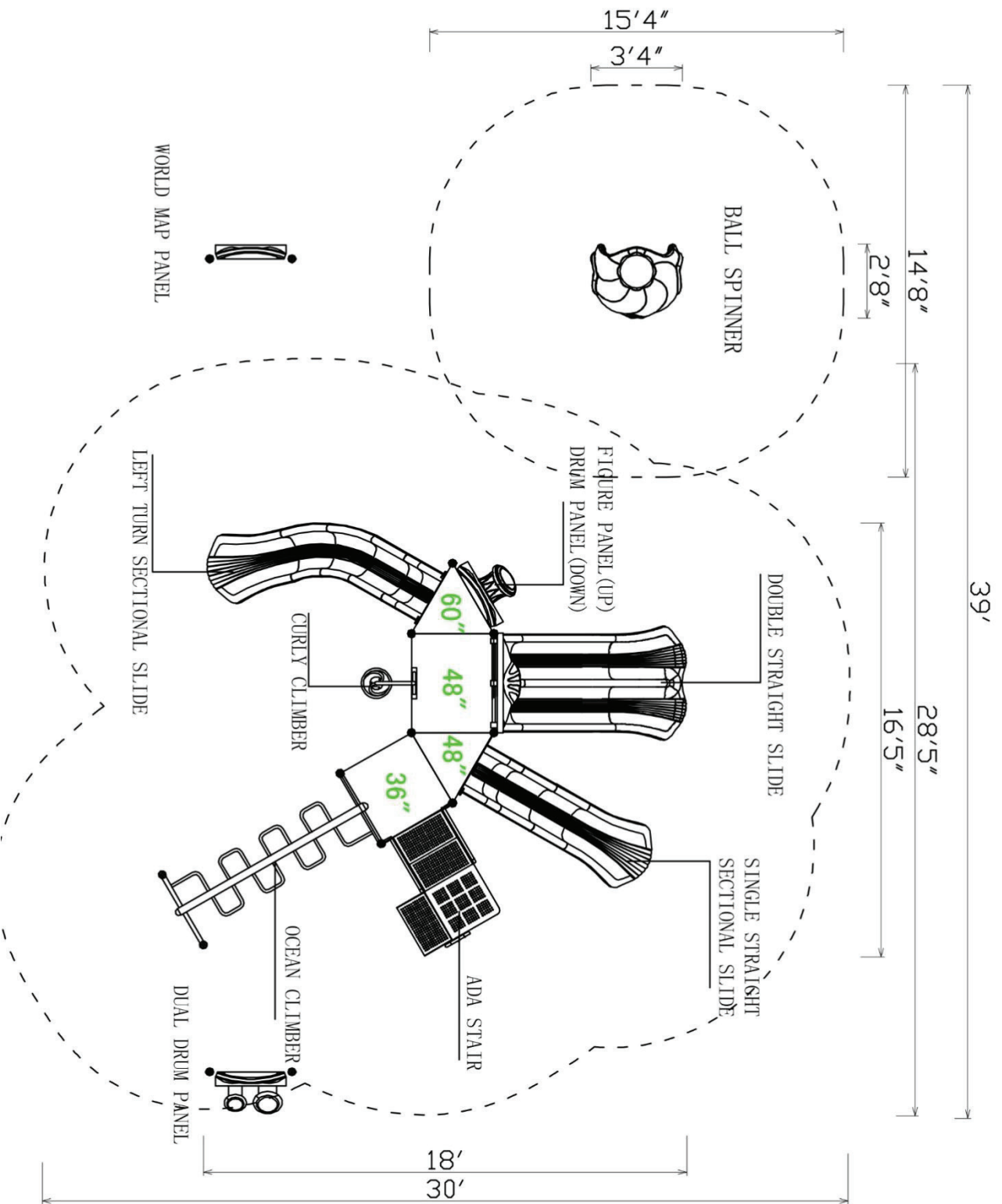

**Notes:**

This play structure design meets ADA accessibility guidelines established in ASTM-1487 and CPSC guidelines. All playground equipment should be installed over ADA accessible safety surfacing

**Critical Fall Height:** 60"

**Structure Size:** 16'5" x 18' x 10'10"

**Use Zone:** 39' x 30'

**Surface Area:** 1170 sq ft

**Child Capacity:** 28-32

**Age Range:** 2-12

**Post Diameter:** 3.5"

**Weight:** 1870 LBS

**Color Information:**

**Posts:** Tan Metal Rails: Tan

**Decks:** Brown

**Slides:** Orange/Sky Blue

**Panels:** Orange/Yellow/Sky Blue