

52CM UNDERMOUNT RANGEHOOD

MODEL / UDMCA52

RRP \$549

FEATURES

- 3 speed settings
- 2 × LED lights
- 1 × Aluminum grease filter
- Push button controls
- Exterior or recirculating venting
- 900m³/hr extraction
- Dishwasher safe aluminum filter

PRODUCT DIMENSIONS

- Product (W *D*H): 700*284*279mm
- Package (W x D x H):
780*335*360mm

WARRANTY

- 24 Months

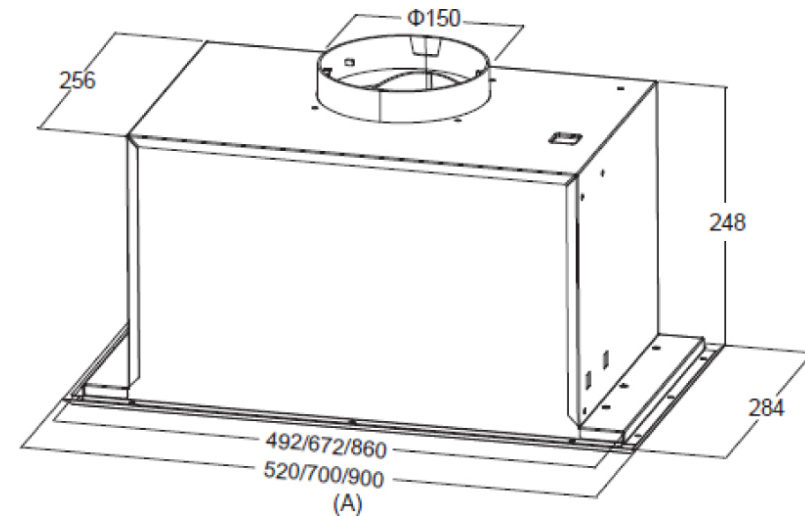

CASA HOME PTY LTD

enquiries@casahome.com.au

www.casahome.com.au

