

IRRADIATION &  
SPECIAL INSTRUCTIONS  
ELECTRIC  
BULLETIN OVEN

EB-56ERCD,EB-56ERC,EB-56ECD,EB-56EC,EB-56E,EB-56RCD,EB-56RC,EB-56R,EB-56ERCD2,  
EB-56ECD2,EB-56RCD2,EB-56ERCD3,EB-56ECD3,EB-56RCD3,EB-56ERCDS,EB-56ERCS,  
EB-56ECDS,EB-56ECS,EB-56ES,EB-56RCDS,EB-56RCS,EB-56RS,EB-56ERCD2S,EB-56ECD2S,  
EB-56RCD2S,EB-56ERCD3S,EB-56ECD3S,EB-56RCD3S,EB-56ERCDG,EB-56ERCG,EB-56ECDG,  
EB-56ECG,EB-56EG,EB-56RCDG,EB-56RCG,EB-56RG,EB-56ERCD2G,EB-56ECD2G,EB-56RCD2G,  
EB-56ERCD3G,EB-56ECD3G,EB-56RCD3G,EB-56ECD4,EB-56ECD4G,EB-56ECD4S,EB-56ERCDA,  
EB-56ERCA,EB-56ECDA,EB-56ECA,EB-56EA,EB-56ERCD2A,EB-56ECD2A,EB-56ERCD3A,  
EB-56ECD3A,EB-56ERCDSA,EB-56ERCSA,EB-56ECDSA,EB-56ECSA,EB-56ESA,EB-56ERCD2SA,  
EB-56ECD2SA,EB-56ERCD3SA,EB-56ECD3SA,EB-56ERCDGA,EB-56ERCGA,EB-56ECDGA,  
EB-56ECGA,EB-56EGA,EB-56ERCD2GA,EB-56ECD2GA,EB-56ERCD3GA,EB-56ECD3GA ,  
EB-56ECD5,EB-56ECD5G,EB-56ERCD5,EB-56ERCD5G.



## **USER INSTRUCTIONS**

### **GENERAL WARNINGS**

Read carefully all the instructions contained in this booklet. It provides you with important information regarding the safe installation, use and maintenance of the appliance as well as useful advice for getting the best out of your oven. Keep this booklet in a safe place for future reference. After removing the packing, check that the appliance is not damaged in any way.

Be careful not to leave the packing materials (plastic sheeting, expanded polystyrene etc.) where children can get at them, as they can be dangerous.

**IMPORTANT:** do not use the oven door handle to move the appliance, such as to remove it from the packaging

### **ATTENTION**

- The oven is an appliance which, for its nature, becomes hot, especially in correspondence of the glass door.
- It is therefore a good rule that children do not approach the oven when it is functioning, particularly when the grill is used.

The first time you switch the oven on, acrid smelling smoke may appear. This is caused by the heating of the adhesive used on the insulation panels surrounding the oven. There is nothing unusual about this. If it happens, simply wait until the smoke disappears before putting any food in the oven. Never roast or bake on the oven base.

### **Safety is a good habit to get into**

- ⊙ This appliance is designed for non-professional, household use and its functions must not be changed.
- ⊙ The electrical system of this appliance may be used safely only when it is correctly connected to an efficient earthing system in compliance with the safety standards currently in effect.
- ⊙ The manufacturer will not be held liable for any damages that might arise out of incorrect installation or improper, incorrect or unreasonable use of the appliance.



The following items are potentially dangerous, and therefore, appropriate measures must be taken to prevent children and the disabled from coming into contact with them:

- Controls and the appliance in general;
- Packaging (bags, polystyrene, nails, etc.);
- The appliance immediately after use of the oven or grill due to the heat generated;
- The appliance when no longer in use (potentially dangerous parts must be made safe).

**Avoid the following:**

- Touching the appliance with wet parts of the body;
- Using the appliance when barefoot;
- Pulling on the appliance or the supply cord to unplug it from the electrical outlet;
- Obstructing the ventilation or heat dissipation slots;
- Allowing power supply cords for small appliances to come into contact with the hot parts of the appliance;
- Exposing the appliance to atmospheric agents (rain, sun);
- Using the oven for storage purposes;
- Using flammable liquids near the appliance;
- Using adaptors, multiple sockets and/or extension cords;
- Attempting to install or repair the appliance without the assistance of qualified personnel.

**WARNING**

- Accessible parts will become hot when in use. To avoid burns and scalds children should be kept away
- During usage, the appliance becomes hot, care should be taken to avoid touching heating elements inside the oven.

**Qualified personnel must be contacted in the following cases:**

- Installation (following the manufacture's instructions);
- When in doubt about operating the appliance;
- Replacing the electrical outlet when it is not compatible with the plug for the appliance.



**Service Canters authorized by the manufacturer must be contacted in the following cases:**

- If in doubt about the soundness of the appliance after removing it from the packaging;
- If the power supply cord has been damaged or needs to be replaced;
- If the appliance breaks down or functions poorly; ask for original spare parts.

**It is a good idea to do as the following:**

- Only use the appliance to cook food, nothing else;
- Check the soundness of the appliance after it has been unpacked;
- Unplugged the appliance from the electrical mains if it is not functioning properly and before cleaning or performing maintenance;
- When the appliance is not used for an extended period of time, unplugged the appliance and close the gas cock (it present);
- Use cooking gloves to place cookware in the oven or when removing it;
- Always grasp the oven door in the centre because the ends may be hot due to the escape of hot air;
- Make sure that the control knobs are on the “o” setting when the appliance is not in use;
- Unplug the appliance when you decide not to use the appliance any longer.

© The manufacturer may not be held responsible for any damage due to: incorrect installation, improper, incorrect and irrational use.

**SPECIFICATION**

The ovens are designed to operate with a monophase alternating current of 220-240V 50Hz. anyway, before the installation of the appliance, we suggest you to check always these specifications on the rating label applied on the outside rear part.

<b>Powers absorbed in accordance with models</b>		<b>Accessories according to models</b>	
Oven lower heating el. 1200Watt	Oven inside heating el. 1900 Watt	Synchromotor	4 Watt
Oven upper heating el. 1000Watt	Total grill heating el. 1000+1900 Watt	Shaded motor (back)	25 Watt
Oven light 15Watt	Circle heating el. 2100Watt	Shaded motor (top)	15Watt

Overall dimensions for oven volume: width 436mm-height 315mm-depth 410mm=56liters



## INDICATOR LIGHTS

The indicator lights situated above the control panel go on and off when the heating elements are inserted or removed. During the thermostatic functioning of the oven, the neon light remains on until the pre-chosen temperature is reached and when it goes out, this is a sign that the temperature has been reached. When the oven cools, the thermostat determines the re-insertion of the heating elements with consequent re-lighting of the indicator lights. In models the internal oven light, which is always on when any function is in operation, is considered as an operation, is considered as an operating warning light.

## INSTALLING THE APPLIANCE

**IMPORTANT: Unplug your oven before performing installation or maintenance!**

Installation should be carried out according to the instructions by a professionally qualified person.

The manufacturer declines all responsibility for any damage to persons, animals or things due to a wrong installation.

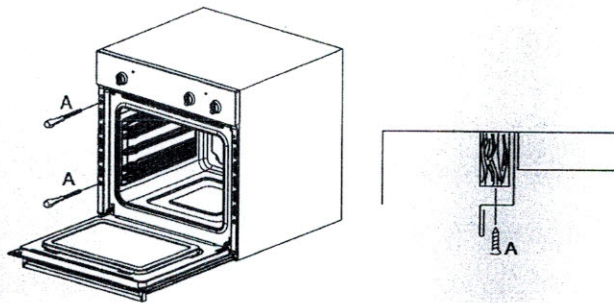

Fig.3

### Fitting the appliance

- Fit the appliance into its surround (beneath a work-top or above another appliance) by inserting screws into the 4 holes that can be seen in the frame of the oven when the door is open.
- For the most efficient air circulation, the oven should be fitted according to the dimensions shown in fig. 1-2 of page 2.
- The rear panel of the cabinet must be removed so that air can circulate freely. The panel to which the oven is fitted should have a gap of at least 70 mm at the rear.

**NB: where ovens are to be matched with hobs, it is essential to follow the instructions contained in the booklet supplied with the other appliance.**



### IMPOTANT

- During use the appliance becomes hot. Care should be taken to avoid touching heating elements inside the oven.
- Accessible parts may become hot during use. Yong children should be kept away.
- Do not use harsh abrasive cleaners or sharp metal scrapers to clean the oven door glass since they can scratch the surface, which may result in shattering of the glass.

For a built-in oven to work well the cabinet must be of the right type.

The panels of the adjoining furniture should be heat resistant. Particularly when the adjoining furniture is made of veneered wood, the adhesives should be able to withstand a temperature of 120°C. Plastic materials or adhesive which cannot withstand this temperature will become deformed or unstuck.

To comply with safety regulations, once the appliance has been fitted it should not be possible to make contact with the electrical parts.

All parts which offer protection should be fixed in such a way that they cannot be removed without the use of a tool.

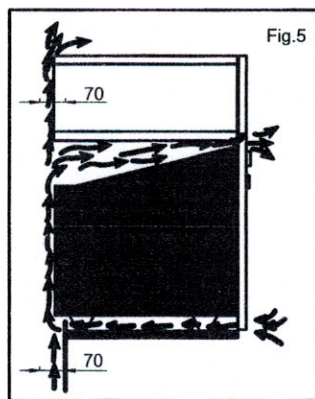
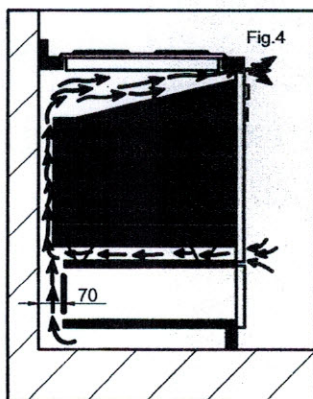

Ensure that the appliance is switched off before replacing the lamp to avoid the possibility of electric shock.

### CONNECTION TO THE MAINS SUPPLY

**THE APPLIANCE MUST BE CONNECTED ACCORDANCE WITH THE RULES CURRENTLY. IT CAN ONLY BE HANDLED BY AN AUTHORIZED ELECTRICAL INSTALLER IF IN FORCE.**



## **WARNING: THIS APPLIANCE MUST BE EARTHED**

- Check that the power rating of the mains supply and of the sockets are suitable for the maximum power of the appliance as indicated on the specification plate.
  - plug should be accessible after installation. Fit the plug into a socket fitted with a third contact which corresponds with the earth connection. This should be properly connected.
  - If the appliance just fitted with supply leads but does not come already fitted with a plug, then permanently connect to fixed wiring as follow:
    - The "yellow/green" earth wire, which must be connected to terminal, has to be about 10mm longer than the other wires; the "blue" neutral wire has to be connected to the terminal marked with letter N.
- "Black, brown, red" live wires have to be connected to terminal L. Mains connection can also be made by fitting a double pole switch with a minimum gap between the contacts of 3mm, proportionate to the load and complying with the regulations in force.

**The yellow/green earth wire should not be controlled by the switch.**

The plug or a double pole switch used for mains supply connection should be easy to get at, once the appliance is in position.

### **IMPORTANT :**

position the mains supply cable so that it is never subjected to a temperature which is more than 50°C above ambient temperature.

- The electrical safety of the appliance can only be guaranteed when it has been correctly connected to an efficient earthed power supply, as laid down in the regulations for electrical safety.
- The manufacturer cannot be held responsible for any damage to persons or objects due to lack of an earth connection.



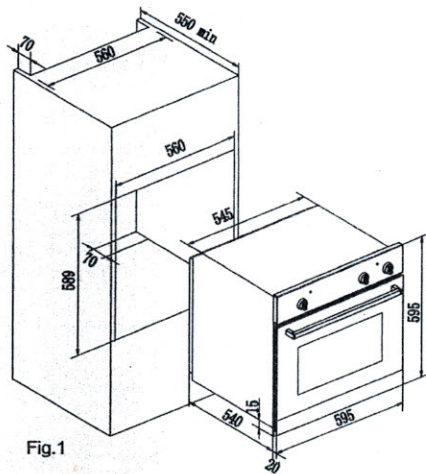

Fig.1

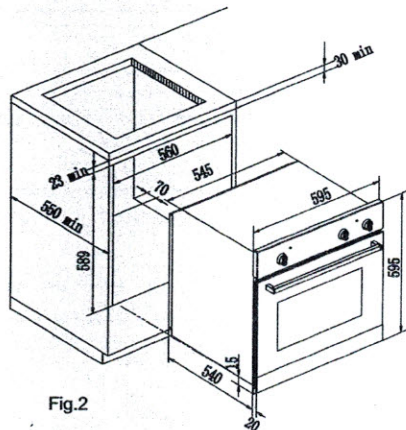

Fig.2

**FITTING DIMENSIONS**

General tolerance for fitting dimension:

Width:  $560 \pm 1,5$  mm

Height:  $589 \pm 2,5$  mm

**N.B.: ENCASTREMENT POUR PLAQUES A GAZ MOD. (...32..P.....) POLYVALENTES**

**N.B.: BUILDING-IN FOR GAS HOBS MOD. (...32..P.....) POLYVALENTS**

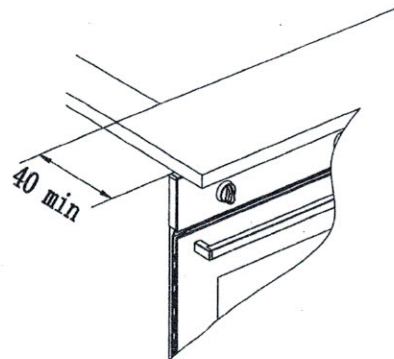







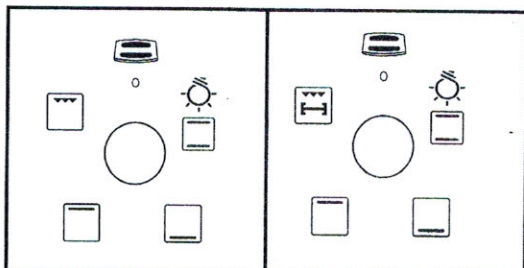



**INSTRUCTIONS FOR USE:** to switch off the oven, turn the knobs on position (O) and (●)

**CONVECTIONAL OVENS 4 FUNCTIONS**









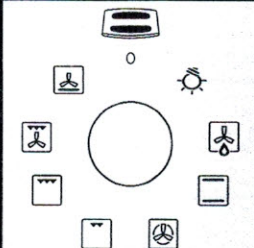
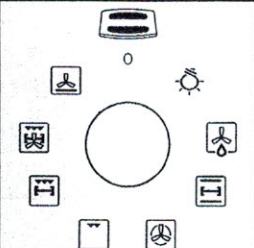

 	<p>When you turn the control knob to position  the light will be on for all the following operations.</p> <p><b>Natural convection</b> Both the lower and upper heating elements operate together. This is the traditional cooking, very good for roasting joints, ideal for biscuits baked apples and crisping food. You obtain very good results when cooking on a shelf</p>
	<p><b>Lower heating element</b> This function is particularly indicated for cooking from the bottom, warming up food or sterilizing glass jars. It is also indicated for food requiring long and slow cooking, i. e. casserole. This function can be used between 50 and MAX°C.</p>
	<p><b>Upper heating element</b> It is indicated for warming up pre-cooked food when placing the grid on the second shelf from the top, or for defrosting pastry placing the grid on the first shelf from the bottom. This function can be used between 50 and MAX°C.</p>
	<p><b>Total grill</b> It is indicated for grilling and gratinating traditional food. This function must always be used with half-open door and control protection in position (see fig. 10-10b).</p>
	<p>Total grill heating element  or (turnspit motor  according to the models, see Fig. 11-12). It is indicated for cooking on the spit, grilling and gratinating. This function must always be used with half-open door and control protection in position (see fig. 10-10b).</p>

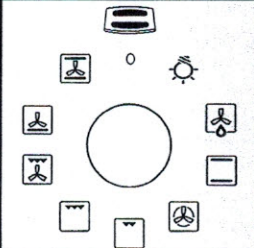
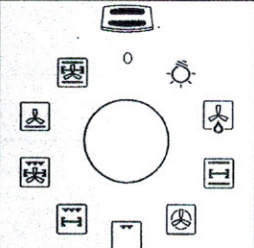
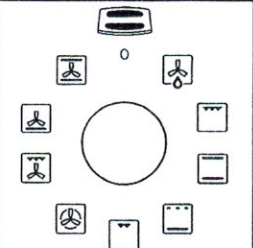











**MULTIFUNCTIONAL OVENS 8 AND 9 FUNCTIONS**

N.B.: All functions will start after selecting the temperature with the thermostat knob.

		
		
	<p><b>Ligh</b> A light in the Oven.</p>	
	<p><b>Defrosting with fan</b> The air at ambient temperature is distributed inside the oven for defrosting food more quickly and without proteins adulteration.</p>	
	<p><b>Natural convention</b> Both the lower and upper heating elements operate together. This is the traditional cooking, very good for roasting joints, ideal for biscuits baked apples and crisping food. You obtain very good results when cooking on a shelf adjusting the temperature between 50 and MAX°C.</p>	
	<p><b>Fan oven</b> Both the fan and the circular heating element operate together. The hot air adjustable between 50 and MAX°C is evenly distributed inside the oven. This is ideal for cooking several types of food (meat, fish) at the same time without affecting taste and smell. It is indicated for delicate pastries.</p>	
	<p><b>Medium grill</b> It is indicated for grilling and gratinating small quantities of traditional food. This function can be used with closed door for very short times (5-10 minutes). For longer times, this function must always be used with half-open door and control protection in position (see fig. 10-10b).</p>	



	<p><b>Total grill</b> It is indicated for grilling and gratinating traditional food. This function must always be used with half-open door and control protection in position (see fig. 10-10b).</p>
	<p>Total grill heating element  or (turnspit motor  according to the models, see Fig. 11-12). It is indicated for cooking on the spit, grilling and gratinating. This function must always be used with half-open door and control protection in position (see fig. 10-10b).</p>
	<p><b>Conventional oven with rotisserie</b> A conventional oven works on the principle that heat rises. It is hotter at the top than at the bottom - ideal for cooking meat in different side simultaneously.</p>
	<p><b>Ventilated Grill</b> Important: do not set thermostat knob (C) to over 175°C. During grilling, keep the oven door closed. All grill components and fan work. In this setting, the central heating elements of the top work. This combination of features compulsory in the air in the oven for the entire cycle of increased non-direct heating elements heat radiation effect. This will allow the heat to penetrate the internal food, and avoid food surface Charred.</p>
	<p><b>Fan assisted total grill</b> The air which is heated by the grill heating element is circulated by the fan and so helps to distribute the heat between 50 and 200°C. This function can be used for sterilizing glass jars.</p>
	<p><b>Conventional oven with rotisserie + Fan</b> The heating element surrounds a fan which distributes hot air around the oven. The result is a more even temperature throughout the oven and much faster cooking.</p>
	<p><b>Lower heating element + Fan</b> The air which is heated by the lower heating element is circulated by the fan and so helps to distribute the heat between 50 and 200°C. This function can be used for sterilizing glass jars.</p>
	<p><b>Intensive Bake</b> The oven is heated by top and bottom elements and the fan mounted in the back panel helps to distribute heat throughout the oven. Suitable for perfect pastry, no need to blind bake.</p>
	<p><b>Upper heating and inside heating Series + Lower heating element</b> This function is used multibarreled has also worked, in the gallbladder gave off heat evenly, the energy consumption was low.</p>



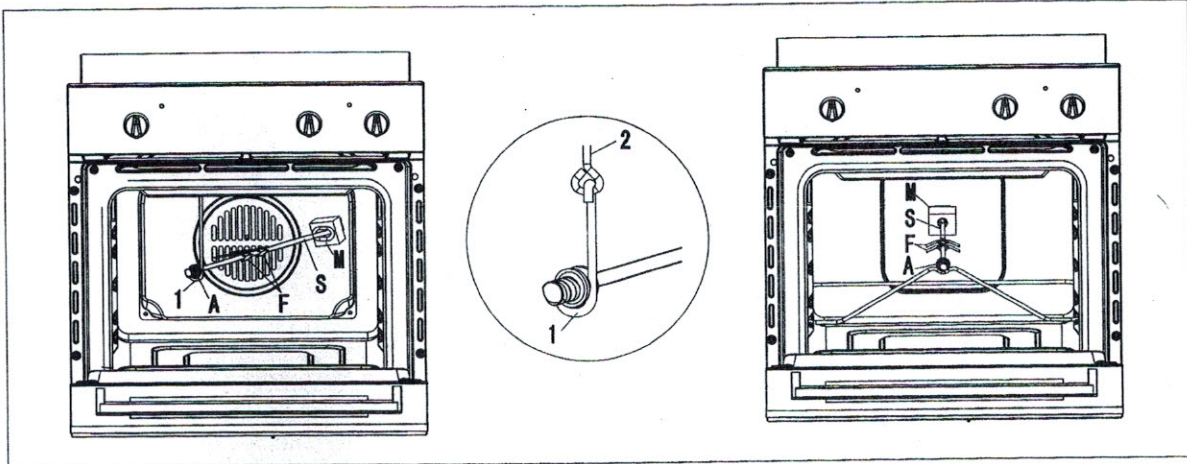





Fig.6

Fig.7

### Using the turnspit

In the "CONVECTIONAL OVEN" models, the turnspit can be used in combination with the grill. After fitting the food on to the spit S, block it with the two forks F, then proceed as follows:

- Fit the knobs protection as shown in (fig. 6)
- Position the spit support as shown in (fig.7)
- Fit the end of the spit into the motor M at the back of the oven (fig. 7).
- Fit the support into the circular groove in the spit.
- Unscrew and remove handle A.
- Place the oven tray with a little water on the lowest shelf of the oven.
- Turn the knob to position  or  or  or  to start up the motor.
- Partially close the oven door (fig. 6b).
- When the cooking time is up, screw the handle on the spit and remove everything from the oven. If necessary, use an oven glove to avoid any burn.



# INSTRUCTIONS FOR USE OF CONTROL DEVICES

## Timers

Our ovens can be fitted with different types of timers:

### MINUTES COUNTERS

Turn the knob clockwise to set the desired cooking time.

The minutes minder can be adjusted from 1 to 60 minutes (Fig. 8) or 1 to 120 minutes (Fig. 9)

A sound signal will inform you that the chosen time is up.

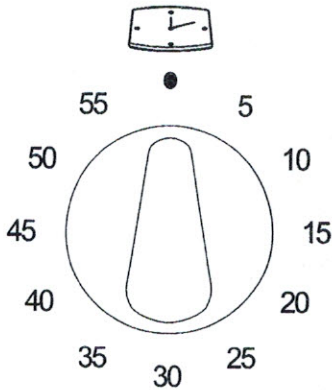

Fig.8

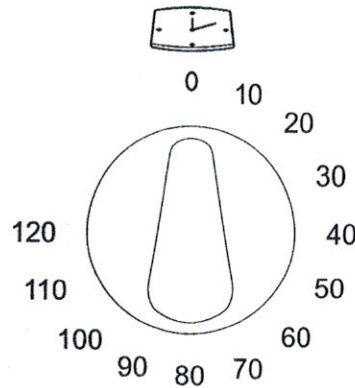
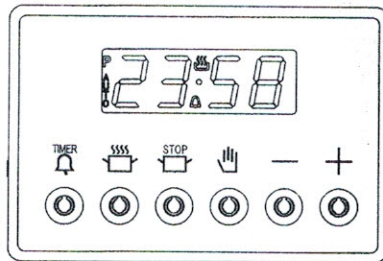

Fig.9

## Operating instructions for Electronic Timer (6 keys)

### <<LED>>PROGRAMMER (fig.10)



	Minutes counter
	Cooking time
	End time
	Manual
	Subtract time
	Add time

Fig.10

### ● Features

24 hours clock with automatic programme and minutes counter

### ● Functions

Cooking time, cooking end time, manual position, clock, minutes counter, times to be set up to 23 hours 59 minutes.

### ● Display

4-figures, 7 segments display for cooking times and time of day.

Cooking time and manual function =saucepan symbol

Automatic function =AUTO

Minutes counter =bell symbol

The symbols light up when the corresponding function is selected

### ● Setting

To set. Press and release the desired function, and set the time with + and buttons within 5 seconds.

### ● Key + and -

The + and buttons increase or decrease the time at a speed depending on how long button is pressed

### ● Setting the time

Press any two buttons (cooking time, end time, minutes counter) at the same time, and + or button to set the desired time. This deletes any previously set programme.

The contacts are switched off and the AUTO symbol flashes.

### ● Manual use

By pressing the manual button the relay contacts switch on, the AUTO symbol switches off and saucepan symbol lights up.

Manual operation can only be enabled after the automatic programme is over or it has been cancelled.

### ● Automatic use

Press the cooking time or end time button to automatically form the manual to the automatic function.

### ● Semi-automatic use with cooking time setting

Press the cooking time button and set the desired time with + or -, the AUTO and cooking time symbols light up continuously. The relay switches on immediately. When the cooking end time corresponds to the time of day, the relay and the cooking time symbol switch off. The sound signal rings and the AUTO symbol flashes.

### ● Semi-automatic use with end time setting

Press the end time button. The time of day appears on the display. Set the cooking end time with + button. The AUTO and cooking time symbols light up continuously. The relay contacts switch on. When the cooking end time corresponds to the time of day, the relay and the cooking time symbol switch off. When the cooking time is up. The AUTO symbol flashes, the sound signal rings and both the relay and the cooking time button switch off.

### ● Automatic use with cooking time and end time setting

Press the cooking time button and select the length of the cooking time with + or button. The AUTO and cooking time symbols light up continuously. The relay switches on. By pressing the cooking end time button the next cooking end time appears on the display. Set the cooking end time with + button. The relay and the cooking time symbol switch off. The symbol lights up again when the time of day corresponds to the cooking start time. When the cooking time is up, the AUTO symbol flashes, the sound signal rings, the cooking time symbol and the relay switch off

### ● Minutes counter

Press the minutes counter button and set the cooking time with + or button.

The bell symbol lights up when the minutes counter is operating, when the set time is up, the sound rings and the bell symbol switches off.

### ● Sound signal

The sound signal starts at the end of a programme or of the minutes counter function and it lasts for 15 minutes.

To stop it, push any functions button.

### ● Start programme and check

The programme will start in 4 seconds after it has been set. The programme can be checked at any time by pressing the corresponding button.

### ● Setting error

A setting error is made if the time of day on the clock falls within the cooking start and end times. To correct the setting error, change the cooking time or cooking end time the relays switch off when a setting error is made.

### ● Cancelling a setting

To cancel a setting, press the cooking time button and then press the button until 00:00 appears on the display. A set programme will be automatically cancelled on completion.



## Electronic Timer Setting (3 keys)



Operating instructions for Electronic Timer (3 keys)



Before using for the first time

Setting and changing the current time

**i** The oven only operates when the time has been set.



When the appliance has been connected to the electrical supply or when there has been a power cut, the function indicator Time  flashes automatically.

1. To change the time that has already been set, press the Selection  button repeatedly, until the function indicator Time  flashes.

2. Set the current time using the  or  button

After approx. 5 seconds, the flashing stops and the clock displays the time of day set.

The appliance is now ready to use.

**i** The time can only be changed if neither of the automatic functions (Cook time  or End time ) have been set.

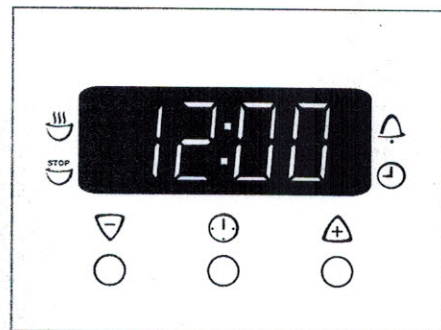
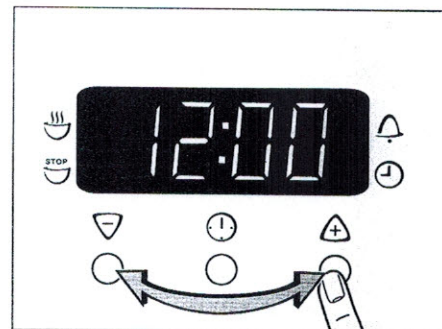
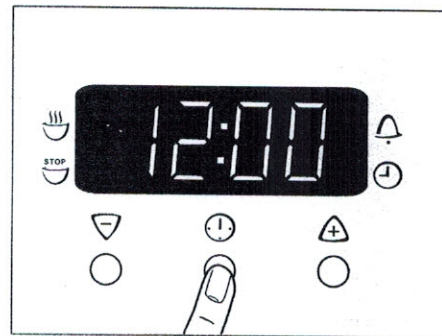

## Clock Functions

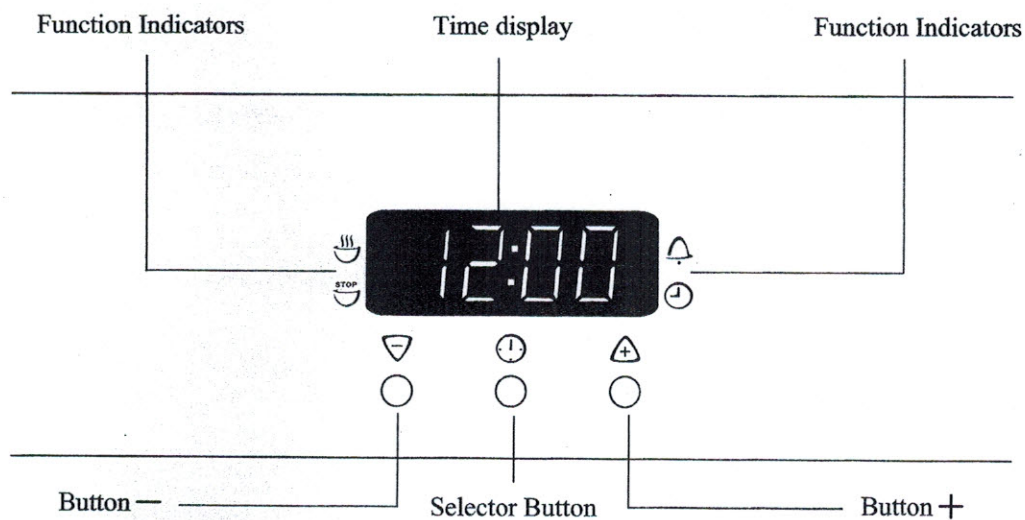

### Countdown

To set a countdown, a signal sounds after the time has elapsed.

This function does not affect the operation of the oven.

### Cook time

To set how long the oven is to be in use.

### End time

To set when the oven is to switch off again.





### Time

To set, change or check the time

(See also section "Before Using for the First Time").



## **i** How to use the clock functions

- When a function has been selected, the corresponding function indicator flashes for approx. 5 seconds. During this time the desired times can be set using the  or  button.
- When the desired time has been set, the function indicator flashes for approx. another 5 seconds. After that the function indicator is then lit. The set time begins to run.
- Press any of the buttons to stop the acoustic signal.
- The desired oven function and temperature can be selected before or after the clock functions of Cook time  and End time  are set.
- When the cooking time has ended, turn the oven function and temperature dial back to the OFF position.

### **Switching off the Time Display**



By switching off the time display you can save energy.

Switching off the time display

Hold down any two buttons until the display becomes dark.



Switching on the time display

Hold down any button until the time reappears in the display.



The display can only be switched off if none of the clock functions Cook time  End time 

or Countdown  are in use.

## Countdown

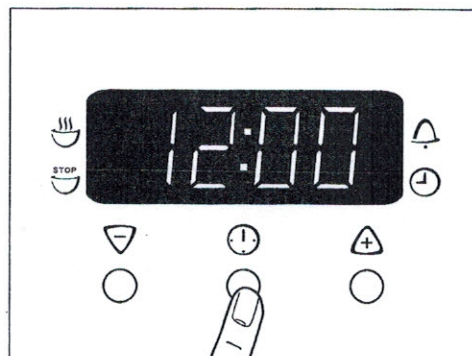
1. Press Selection  button repeatedly, until the function indicator Countdown  flashes.



2. Using the  or  button, set the required Countdown (m ax. 2 hours 30 minutes).

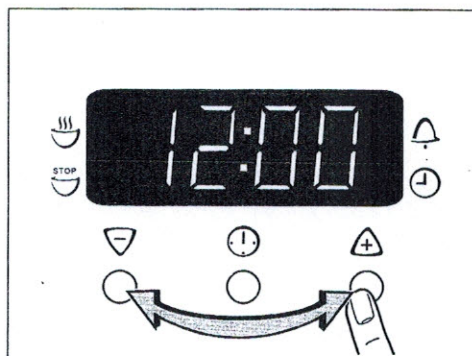

After approx. 5 seconds, the display shows the remaining time.

The function indicator Countdown  will light up.

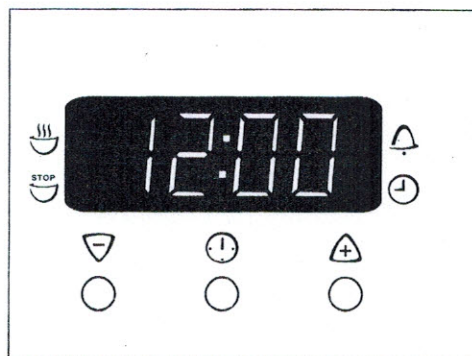

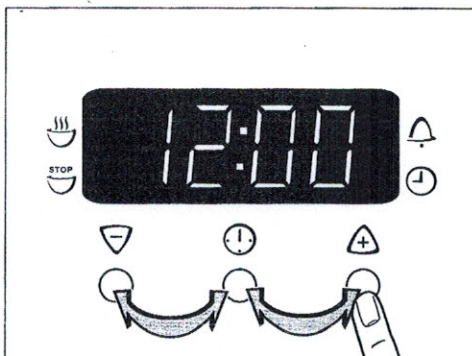

When the time has elapsed, the function indicator flashes and an acoustic signal sounds for 2 minutes.

Press any button to switch off the signal.





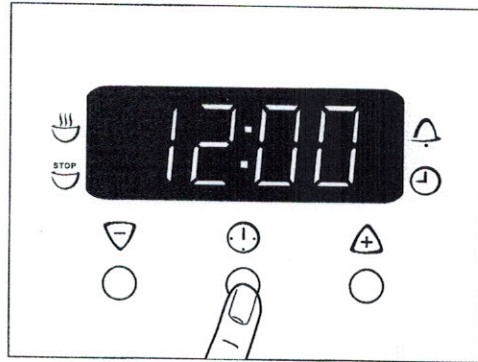

## Cook time

1. Press Selection  button repeatedly, until the function indicator Cook time  flashes.

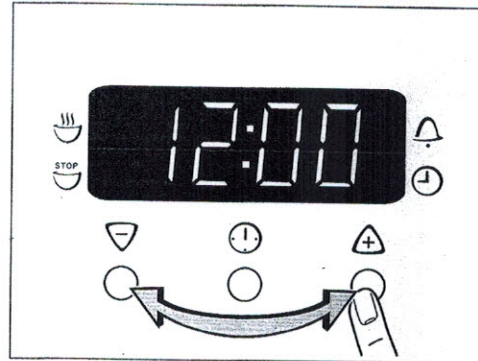

2. Using the  or  button, set the required cooking time.



After approx. 5 seconds, the display returns to the current time. The function indicator Cook time  will light up.

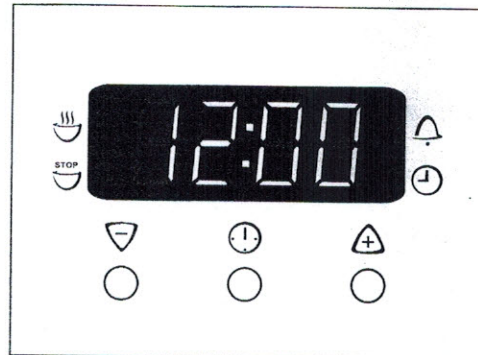



When the time has elapsed, the function indicator will flash, an acoustic signal will sound for 2 minutes and the oven will switch itself off.

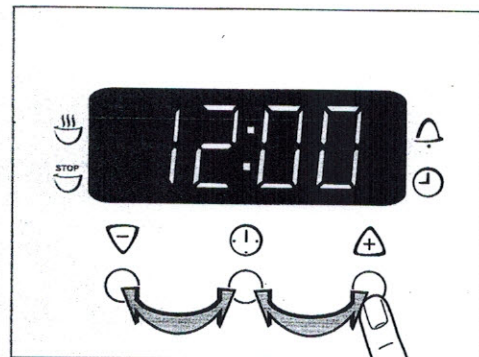

3. Press any button to switch off the signal and the program me.

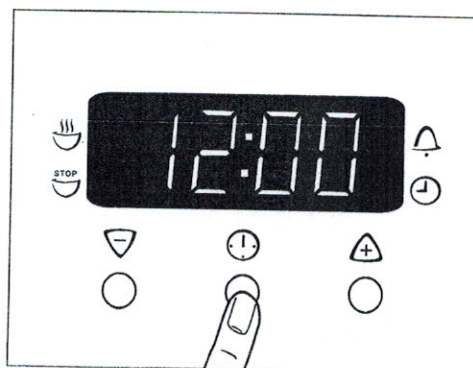

## End time

1. Press Selection  button repeatedly, until the function indicator End time  flashes.



2. Using the  or  button, set the required switch-off time.

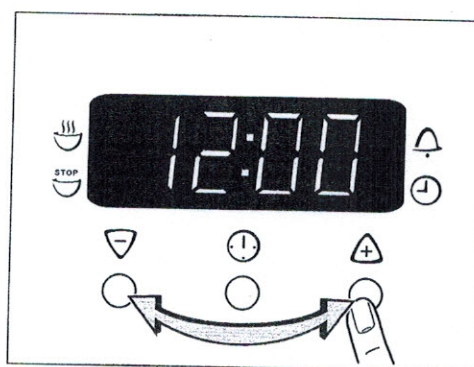

After approx. 5 seconds, the display returns to the current time.

The function indicator End time  will light up.

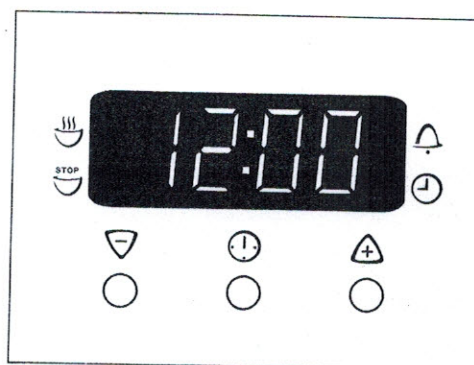

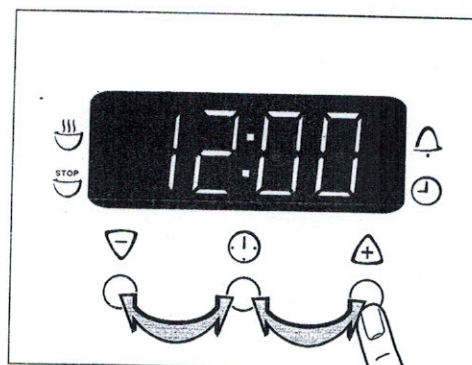

When the time has lapsed, the function indicator will flash, an acoustic signal will sound for 2 minutes and the oven will switch itself off.

3. Press any button to switch off the signal and the program.







## Cook time and End time combined

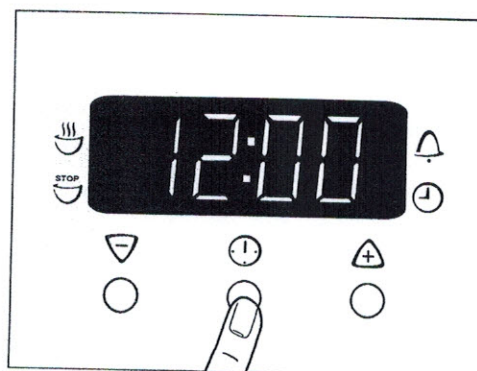

Cook time  and End time  can be used simultaneously, if the oven is to be automatically switched on and off at a later time.

1. Using the function Cook time  set the Period of time that the dish requires to cook .  
In this example, 1 hour.

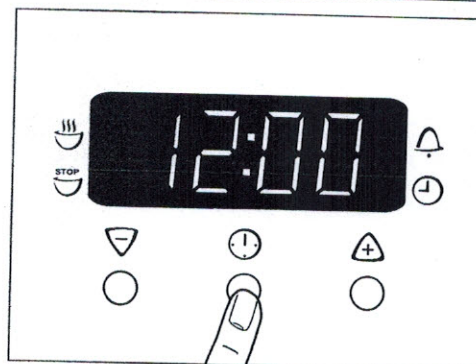

2. Using the function End time , set the time at which the dish is to be ready.  
In this example, 14:05.



The function indicators Cook time  and End time  light up and the time is shown in the display.

In this example, 12:05.

The oven will automatically switch itself on at the appropriate time as calculated.

In this example, at 13:05.

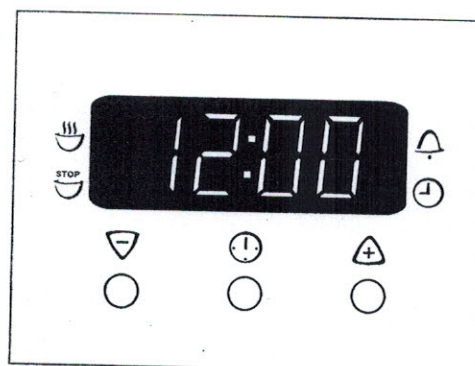

And will switch itself off when the cooking time set has elapsed.

In this example, at 14:05.





## Touch Control Timer Setting (3 keys)

### Before using for the first time

#### Setting and changing the current time



The oven only operates when the time has been set.

When the appliance has been connected to the electrical supply or when there has been a power cut, the function indicator Time  flashes automatically.

1. To change the time that has already been set, press the Selection  button repeatedly, until the function indicator Time  flashes.
2. Set the current time using the  or  button.

After approx. 5 seconds, the flashing stops and the clock displays the time of day set.

The appliance is now ready to use.

The time can only be changed if neither of the automatic functions (Cook time  or End time ) have been set.

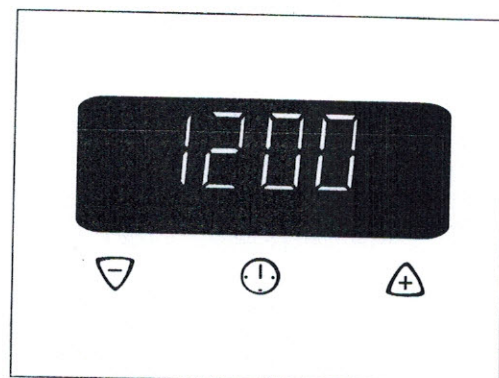
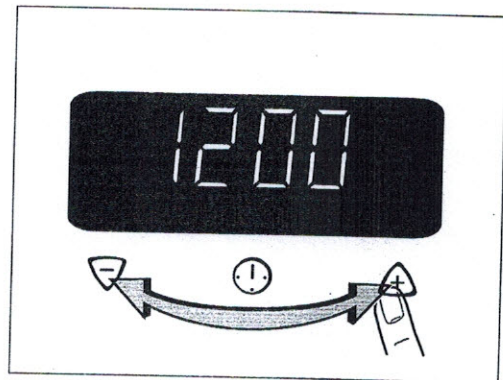
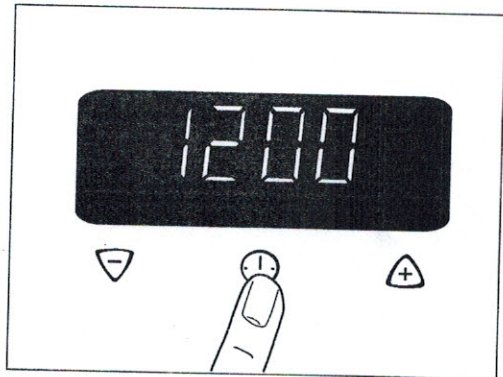



## Clock Functions

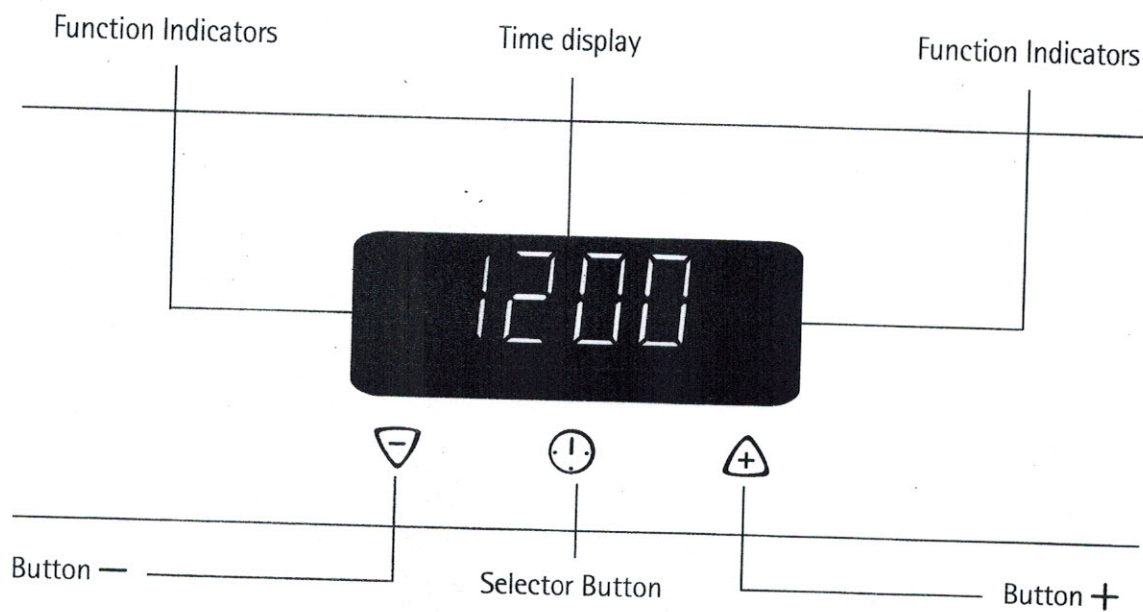

### Countdown

To set a countdown, a signal sounds after the time has elapsed.

This function does not affect the operation of the oven.

### Cook time

To set how long the oven is to be in use.

### End time





To set when the oven is to switch off again.

### Time

To set, change or check the time

(See also section "Before Using for the First Time").

## **How to use the clock functions**

- When a function has been selected, the corresponding function indicator flashes for approx. 5 seconds. During this time the desired times can be set using the  or  button.
- When the desired time has been set, the function indicator flashes for approx. another 5 seconds. After that the function indicator is then lit. The set time begins to run.
- Press any of the buttons to stop the acoustic signal.
- The desired oven function and temperature can be selected before or after the clock functions Cook time  and End time  are set.
- When the cooking time has ended, turn the oven function and temperature dial back to the OFF position.



### **Switching Off the Time Display**

By switching off the time display you can save energy.

#### **Switching off the time display**

Hold down any two buttons until the display becomes dark.

#### **Switching on the time display**

Hold down any button until the time reappears in the display.





The display can only be switched off if none of the clock functions Cook time



End time or Countdown are in use.

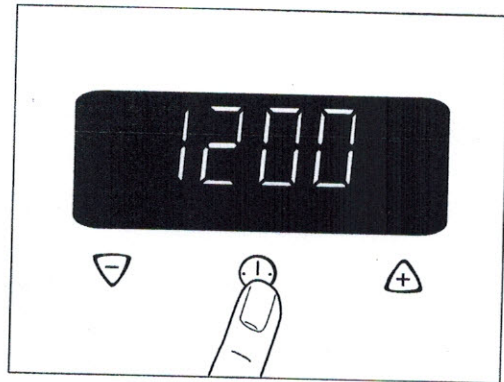

## Countdown

1. Press Selection  button repeatedly, until the function indicator Countdown  flashes.



2. Using the  or  button, set the required Countdown (max. 2 hours 30 minutes).

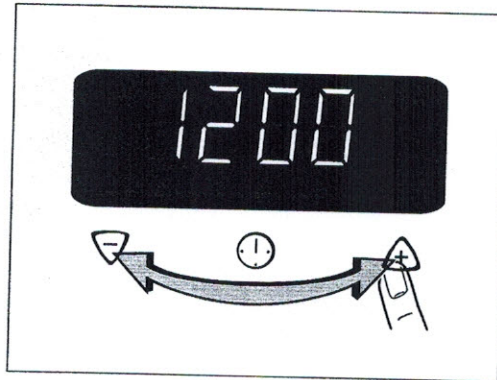

After approx. 5 seconds, the display shows the remaining time.

The function indicator Countdown  will light up.

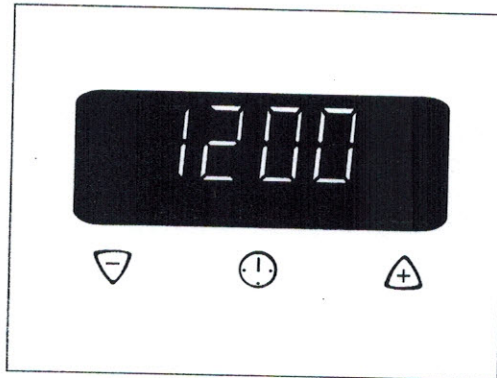



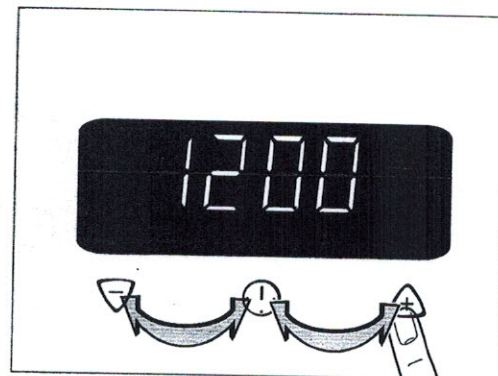

When the time has elapsed, the function indicator flashes and an acoustic signal sounds for 2 minutes.

Press any button to switch off the signal.



**Cook time** 

1. Press Selection  button repeatedly, until the function indicator Cook time  flashes.

2. Using the  or  button, set the required cooking time.

After approx. 5 seconds, the display returns to the current time. The function indicator Cook time  will light up.

When the time has elapsed, the function indicator will flash, an acoustic signal will sound for 2 minutes and the oven will switch itself off.

3. Press any button to switch off the signal and the program me.

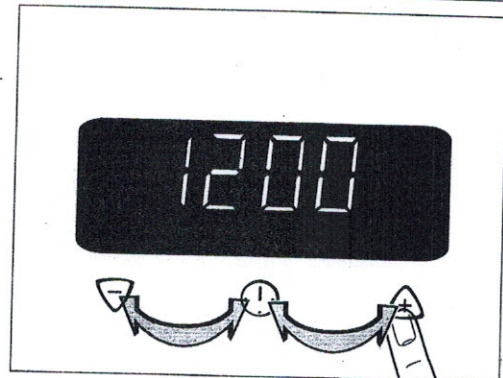
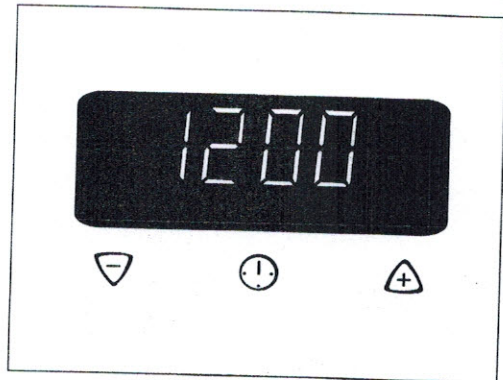
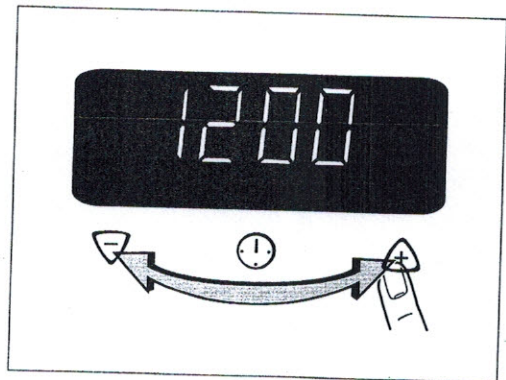
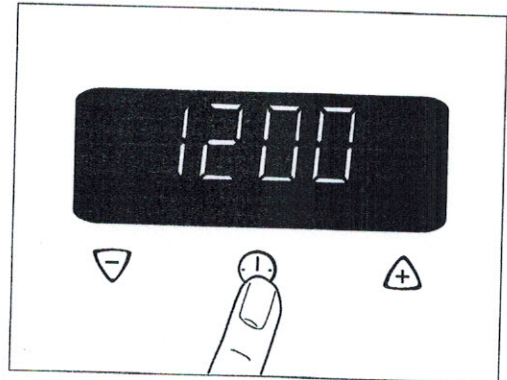



## End time ⌚

1. Press Selection ⌚ button repeatedly, until the function indicator End time ⌚ flashes.

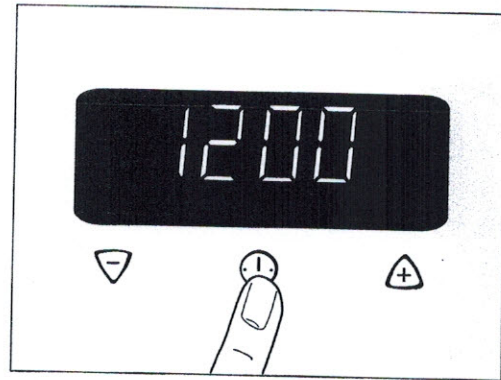

2. Using the + or - button, set the required switch-off time.

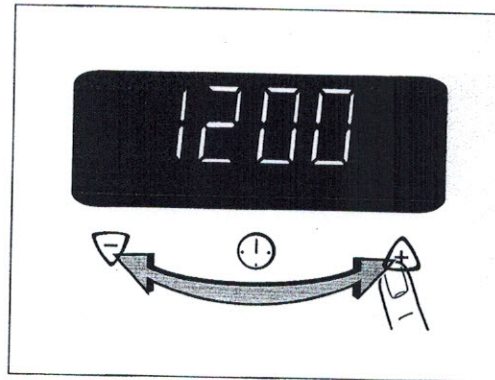

After approx. 5 seconds, the display returns to the current time.

The function indicator End time ⌚ will light up.

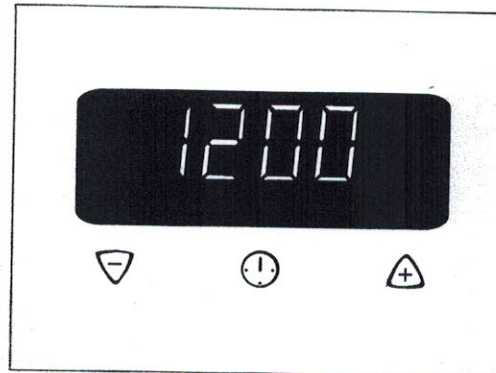

When the time has lapsed, the function indicator will flash, an acoustic signal will sound for 2 minutes and the oven will switch itself off.

3. Press any button to switch off the signal and the program me.

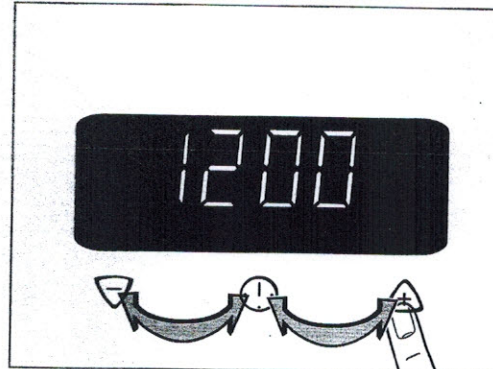

Cook time  $\Delta$  and End time  $\odot$  combined

Cook time  $\Delta$  and End time  $\odot$  can be used simultaneously, if the oven is to be automatically switched on and off at a later time.

1. Using the function Cook time  $\Delta$  set the period of time that the dish requires to cook.

In this example, 1 hour.

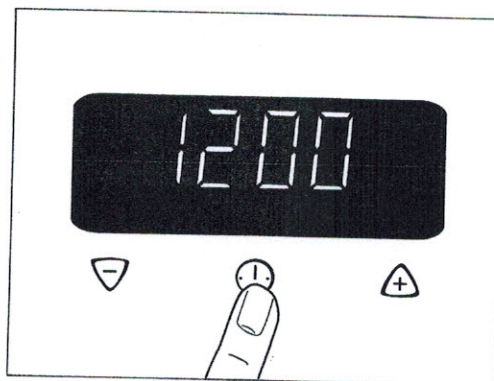

2. Using the function End time  $\odot$ , set the time at which the dish is to be ready.

In this example, 14:05.

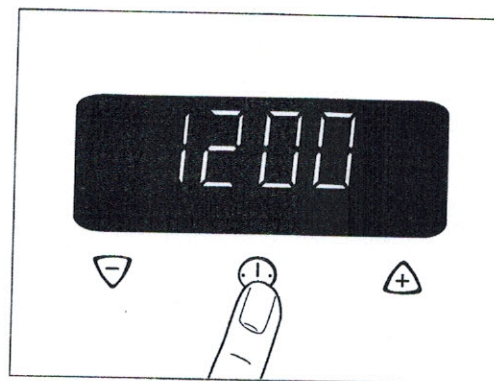

The function indicators Cook time  $\Delta$  and End time  $\odot$  light up and the time is shown in the display.

In this example, 12:05.

The oven will automatically switch itself on at the appropriate time as calculated.

In this example, at 13:05.

And will switch itself off when the cooking time set has elapsed.

In this example, at 14:05.

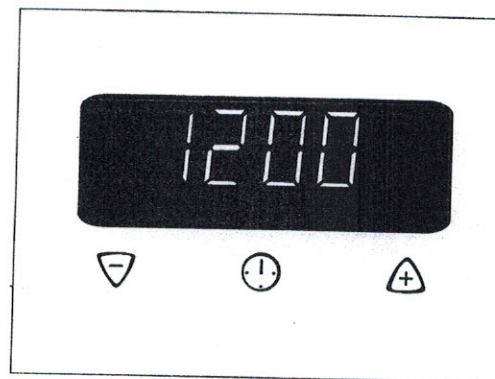





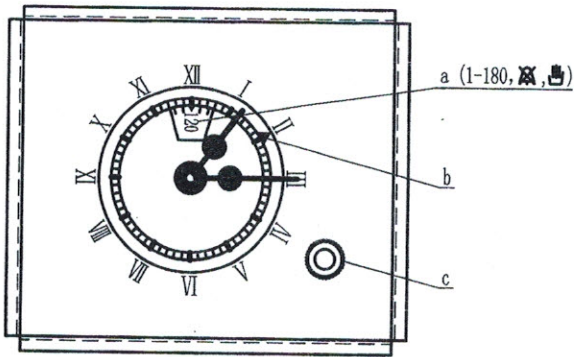



## Classic Timer Operation



### 1. Function and the symbol

- a、 0-180 Cooking time
- a、  Disable timer function
- a、  Manual mode
- b、  Cooking start symbol
- c、  Adjustable joystick

### 2. Operation instruction











- 1) Timer setting: Press and turn the adjustable joystick counterclockwise to set the time.
- 2) Cooking start time setting: Pull and turn the adjustable joystick counterclockwise to set the cooking start time. The symbol  is indicated around the clock dial.
- 3) Cooking time setting: Turn the adjustable joystick counterclockwise to set your desired time (time can be set between 0 to 180 min). The oven starts to cook when the pre-set cooking start time comes. When the cooking time is over, the classic timer rings. User can turn the adjustable joystick counterclockwise to the symbol  to stop the ring.

For example: The time is 1:15 now. User sets the cooking start time to 2:00 and sets the cooking time to 120 min. When 2:00 comes, the oven starts to cook for 120 min.













- 4) Manual mode: Turn the adjustable joystick counterclockwise to the symbol . Then set the cooking start time as above instruction. The oven starts to cook when the pre-set cooking start time comes. The user needs to turn the function selector to "0" to stop cooking.

## Full Touch Control Operation

### Key operation:



									
Main on/off switch	Plus key	Minus key	Light	Timer	Info	Minus	Plus	Rapid heat-up	OK

### 1. Time of Day / Minute Minder / Cooking time / End of time setting :

- 1) Time of Day: press  to adjust the time before you switch the on/off key .
- 2) Minute Minder  :press  to set the cooking time, press  to start cooking. The Minute Minder count down starts to 0:00 (min:sec). The display shows the symbol  and the remaining time is displayed continuously.
- 3) Cooking time  :press  to set the cooking time 00:00 (hour: min), press  to start cooking.
- 4) End of cooking time  :after user sets the cooking time  , press the key  to set the end of cooking time. The oven starts as soon as the start time reaches.

For example: The time is 12:00 now, user sets the cooking time to 0:30(hour: min), then press  to set the end of time to 12:40. The oven starts to cook at 12:10, and the display shows the remaining time of cooking.

### 2. Function setting



- 1) Press the key  to switch on the oven .User can select the different cooking modes by pressing the key.
- 2) Temperature can be set by the key  after the cooking mode is selected, once the cooking mode and the temperature is fixed, press the key  to start cooking.

### 3. Rapid heat-up

When the setting temperature exceeds 100 digress and the pre heat function hasn't been finished, user can press the key  to start the rapid heat-up mode.



#### 4. Configuration setting:

Press the “Info” key  for 5 seconds to set the mode. Then press the “Info” again to select Mode 1, Mode 2, Mode 3, Mode 4, Mode 5, Mode 6. Once selecting the mode, user can press / to select option 1, 2 or 3.

Mode	Description	Option 1	Option 2	Option 3
Mode 1	Time display	Display always	Display when oven is working	
Mode 2	“Beep” sound after the time count down	Short	Medium	Long
Mode 3	Duration of time setting	Short	Medium	Long
Mode 4	Cooling fan working time after oven finishes cooking	Short	Medium	Long
Mode 5	Display brightness	Dark	Medium	Bright
Mode 6	“Beep” sound when selecting the function mode	No	Yes	

After user finish the selection of “Info” mode, press the key  to confirm.

#### 5. Cooking mode symbol:

The sequence of cooking modes displayed in the screen as below:

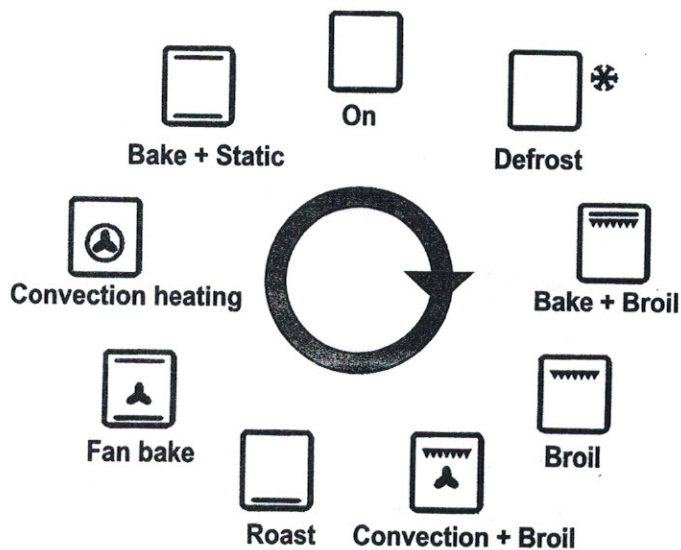

6. Child-safety lock: Press the  bottom for 5 sec after you switch off the oven.

## How to keep Your Oven in Shape

This appliance is for household use only, don't use it outdoors!

Important: Unplug your oven before cleaning, or performing maintenance!

To extend the life of your oven, it must be cleaned frequently, keeping in mind that:

- ⊙ **Do not use steam equipment to clean the appliance.**
- ⊙ To protect against the risk of electrical shock, do not immerse the unit, cord or plug in water or other liquid or sprinkle water to clean the appliance!
- ⊙ Don't clean the appliance when it still hot! The inside and external surface of the oven should preferably be cleaned by damp cloth when it is cooled down.
- ⊙ Wash all accessories in hot sudsy water or in a dishwasher, wipe dry with a paper or cloth towel.
- ⊙ If you use your oven for an extended period of time, condensation may form. Dry it using a soft cloth.
- ⊙ There is a rubber seal surrounding the oven opening which guarantees its perfect functioning. Check the condition of this seal on a regular basis. If necessary, clean it and avoid using abrasive products or objects to do so. Should it become damaged, please contact your nearest After-sales Service Centre. We recommend you avoid using the oven until it has been repaired.
- ⊙ Never line the oven bottom with aluminium foil, as the consequent accumulation of heat could compromise the cooking and even damage the enamel.
- ⊙ Clear the glass door using damp cloth and dry it with a soft cloth.

Do not use harsh abrasive cleaners or sharp metal scrapers to clean the oven door glass since they can scratch the surface, which may result in shattering of the glass.

### Replacing the Lamp in the Oven

- ⊙ Unplug your oven!
- ⊙ Unscrew the glass cover attached to the lamp holder;
- ⊙ Unscrew the lamp and replace it with another high-temperature lamp (300°C) with the following characteristics:

- Voltage: AC220V-240V
- Wattage: 15W
- Socket: E 14

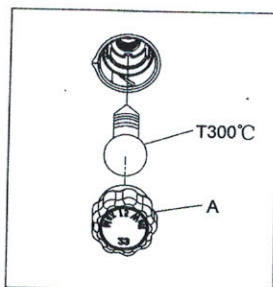

- ⊙ Remount the glass cover and reconnect the appliance to the power supply.



**WARNING:** Ensure that the appliance is unplugged before replacing the lamp to avoid the possibility of electric shock.

**Warning:** Do not operate appliance with damaged cord or plug or after the appliance malfunctions, or has been damaged in any manner, return appliance to the nearest Authorized Service Center for examination.

**Repair, or adjustment!**

#### **USEFUL NOTES FOR COOKING**

In the following table, some indicative hints for cooking:

FAULTS	CAUSES	REMEDIES
The upper crust is dark and the lower part too pale	Not enough heat from the bottom	<ul style="list-style-type: none"><li>- Use the natural convection position</li><li>- Use deeper cake tins</li><li>- Lower the temperature</li><li>- Put the cake on a lower shelf</li></ul>
The lower part is dark and the upper crust too pale	Excessive heat from the bottom	<ul style="list-style-type: none"><li>- Use the natural convection position</li><li>- Use lower side tins</li><li>- Lower the temperature</li><li>- Put the cake on a higher shelf</li></ul>
The outside is too cooked and the inside not cooked enough	Too high temperature	<ul style="list-style-type: none"><li>- Lower the temperature and increase the cooking time</li></ul>
The outside is too dry even though of the right color	Too low temperature	<ul style="list-style-type: none"><li>- Increase the temperature and reduce the cooking time.</li></ul>

#### Protective kit

During operation, the oven glass door and adjacent parts of the appliance become hot. Make sure, therefore, that children do not touch the appliance.

This appliance is not intended for use by persons (including children) with reduced physical, sensory or mental capabilities or lack of experience and knowledge, unless they have been given supervision or instruction concerning use of the appliance by a person responsible for their safety.

Children should be supervised to ensure that they do not play with the appliance.

For greater safety, an additional child-safety device is available from our Head Office and our Authorized Service Centres (see enclosed list). When ordering this, please give the code: BAB-followed by the appliance model. The model is stamped on the plate which is visible on the front part of the oven upon opening the door.

### Disassembling/assembling the oven door

To make it easier to clean the inside of your oven, the oven door can be removed, by proceeding as follows (fig. 11):

- Open the door completely and lift the 2 levers "B" (fig.11-1);
- Now, shutting the door slightly, you can lift it out by pulling out the hooks "A" as shown in figure 2.

To reassemble the door:

- With the door in a vertical position, insert the two hooks "A" into the slots;
- Ensure that seat "D" is hooked perfectly onto the edge of the slot (move the oven door backwards and forward slightly);
- Keep the oven door open fully, unhook the 2 levers "B" downwards and then shut the door again.

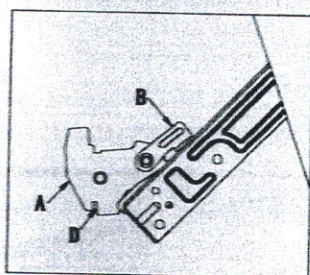

Fig.11-1

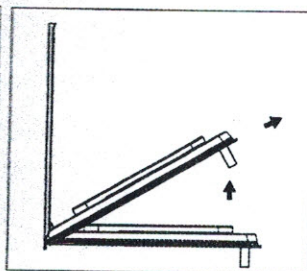

Fig.11-2

### Instruction of Removable Glazing Door

The oven door is made up of 3 panes of glass and has vents at the top and bottom. When the oven is operating,

air is circulated through the door to keep the outer pane cool. If condensation has worked its way in between the

glass panes, the door can be dismantled in order to clean in between the panes.

Remove the door as per above instruction and place it on a protective surface (e.g. on a table cloth) to prevent it

getting scratched. The door handle should line up with the edge of the table. Make sure the glass lies flat to avoid

breakage of glass during cleaning.

1. Undo the 2 screws on upper bracket.
2. Take out upper bracket and first pane of glass.
3. Loosen the 4 clips.
4. Slide out middle pane of glass carefully. Clean the glass panes and other parts with a damp microfibre cloth or a clean sponge and a solution of hot water with a little washing-up liquid. Wipe dry using a soft cloth.



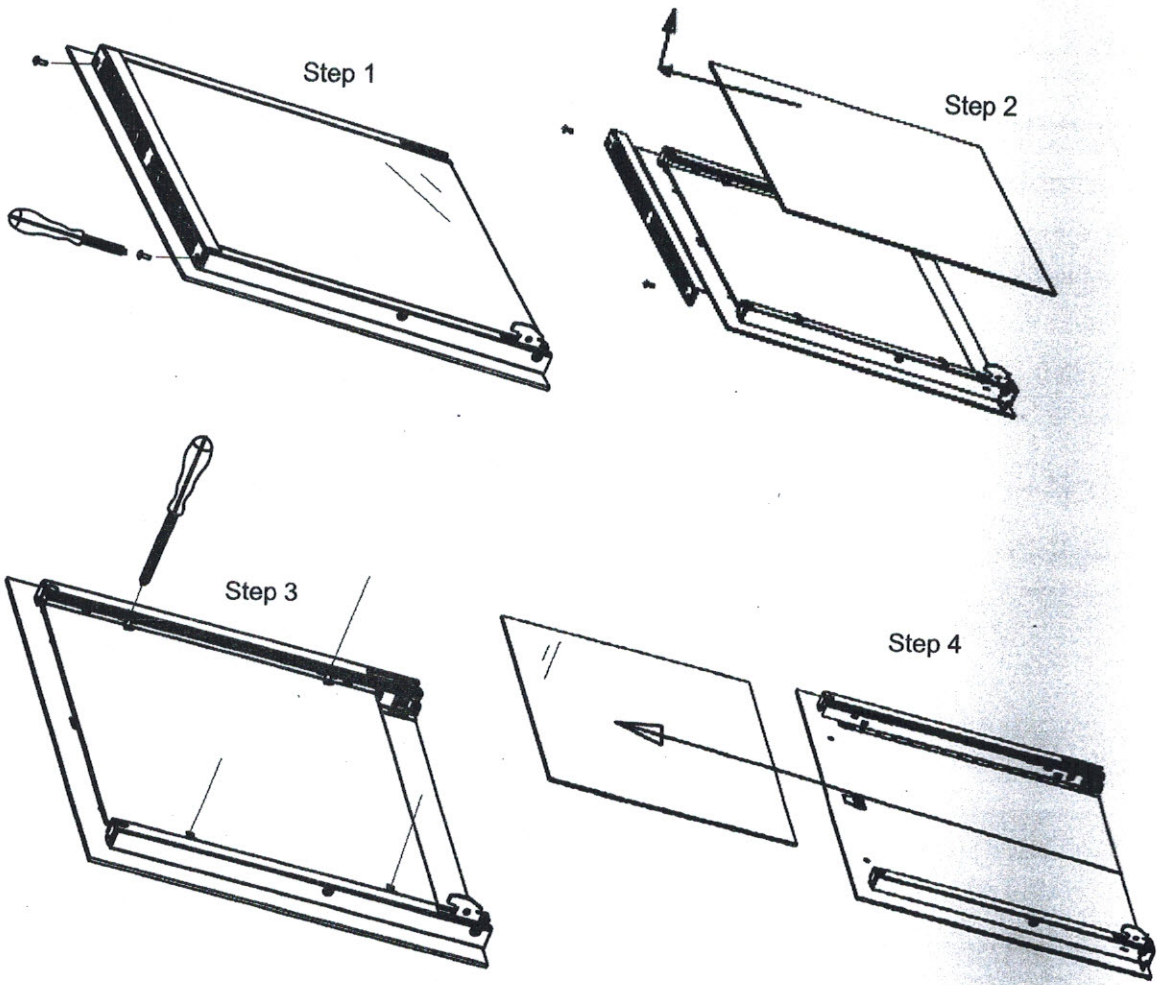

**Instruction of Side-opening Door**

the side door can be removed , by proceeding as follows (fig.12):

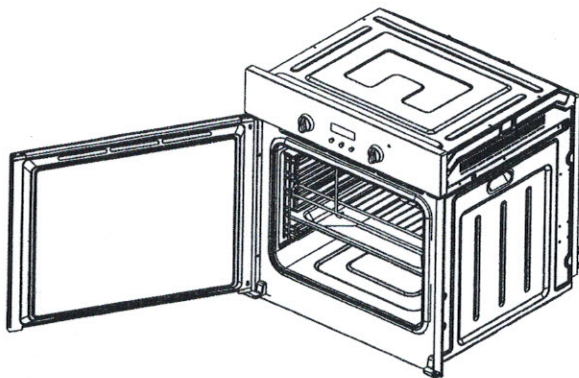

**Fig.12-1**

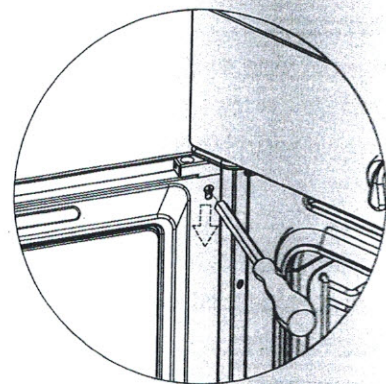

**Fig.12-2**

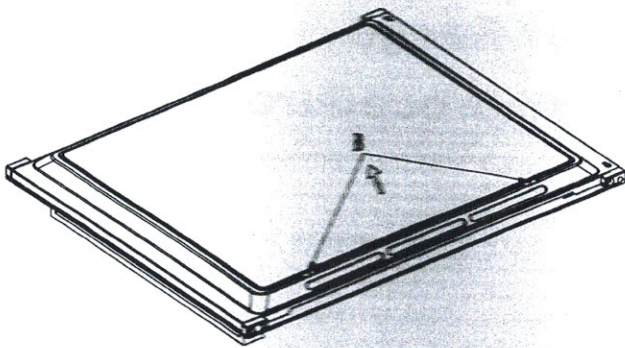

**Fig.12-3**

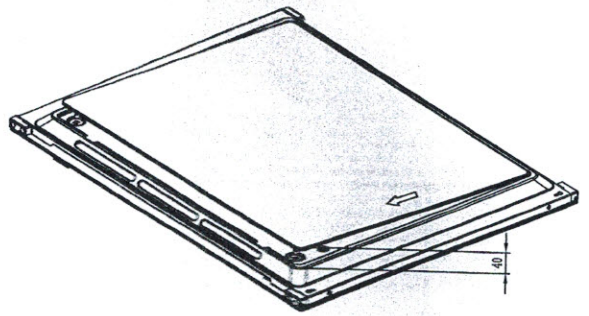

**Fig.12-4**

**Removal of Side-door oven**

- a) by opening the door, take out the screw at position A by a screwdriver, then you can take the whole oven door separately.(fig.12-1, fig.12-2)
- b) put the oven door on a flat surface, use a flatten objects, such as coins, to levering the glass at the position B.(fig.12-3)
- c) make the glass on the position of with about 40mm height, DO NOT take it too high as it will broken the frame. Then pull it glass out with the direction as fig.12-4. In this way, it is easy to clear the glass of oven door.

**Remark:**

If only want to clear the internal glass, not the whol oven door, just operate with instruction b) and c).



This product must not be disposed together with the domestic waste. This product has to be disposed at an authorized place for recycling of electrical and electronic appliances.

By collecting and recycling waste, you help save natural resources, and make sure the product is disposed in an environmental friendly and healthy way.

**Important:** if you decide not to use the oven any more, it should be made inoperable by cutting the power supply cable, after unplugging it from the power supply. Disused appliances can be a safety risk as children often play with them. For this reason it is advisable to make the oven safe.

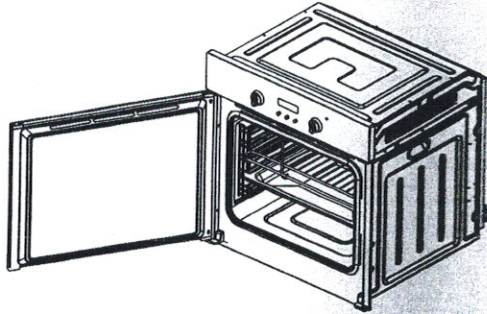
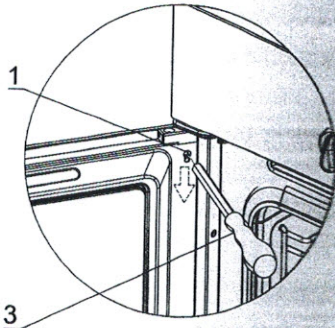
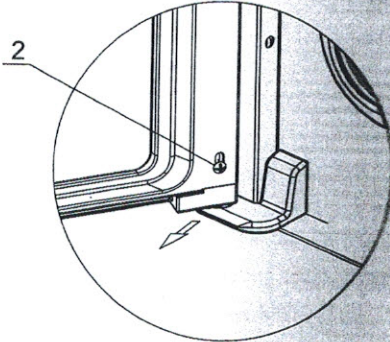
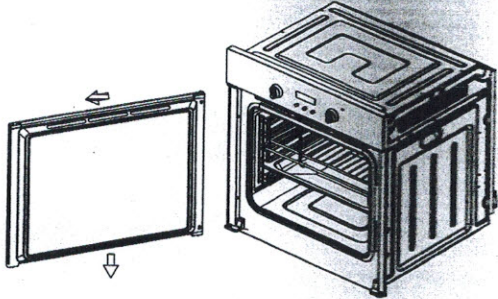

## Side-opening Door Range Door Direction-change procedure

Procedure	Description	Image
1	Open the door to proper angle	
2	Unscrew screw 1 with screwdriver 3, push screw 1 downward, and then pull the door out from up fixed support.	
3	Take the door out from down fixed support directly.	
4	Door is completely taken out from door spindle.	

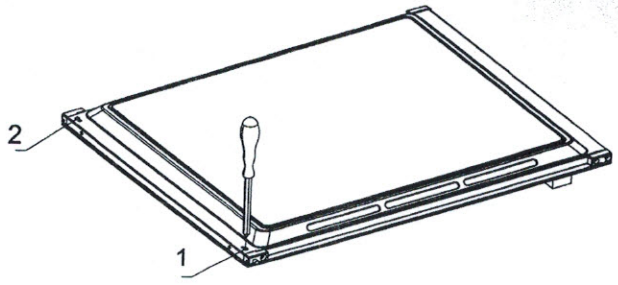
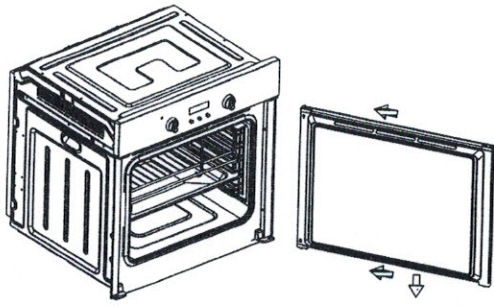
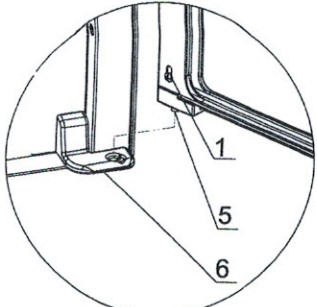
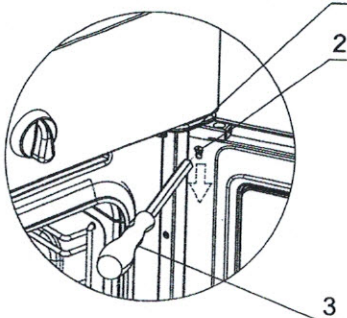

5	Screw up 1 and screw off 2.	
6	Prepare to assemble the door to opposite door spindle. At this moment, screw 1 is downward, screw 2 is upward.	
7	Assemble the door to down fixed support, put fulcrum 5 to down fixed support 6.	
8	Assemble the door to up fixed support, screw up screw 2 with screwdriver 3.	
9	Door direction is completely changed.	