

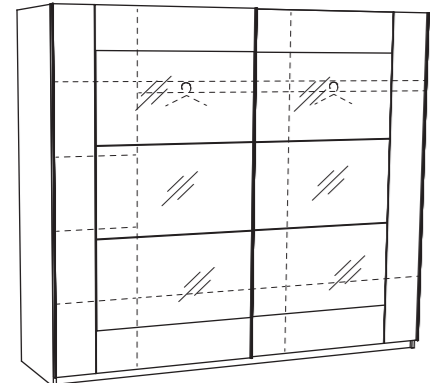

montage instructies
instructions de montage
assembly instructions
montage anleitung

NANI

S25

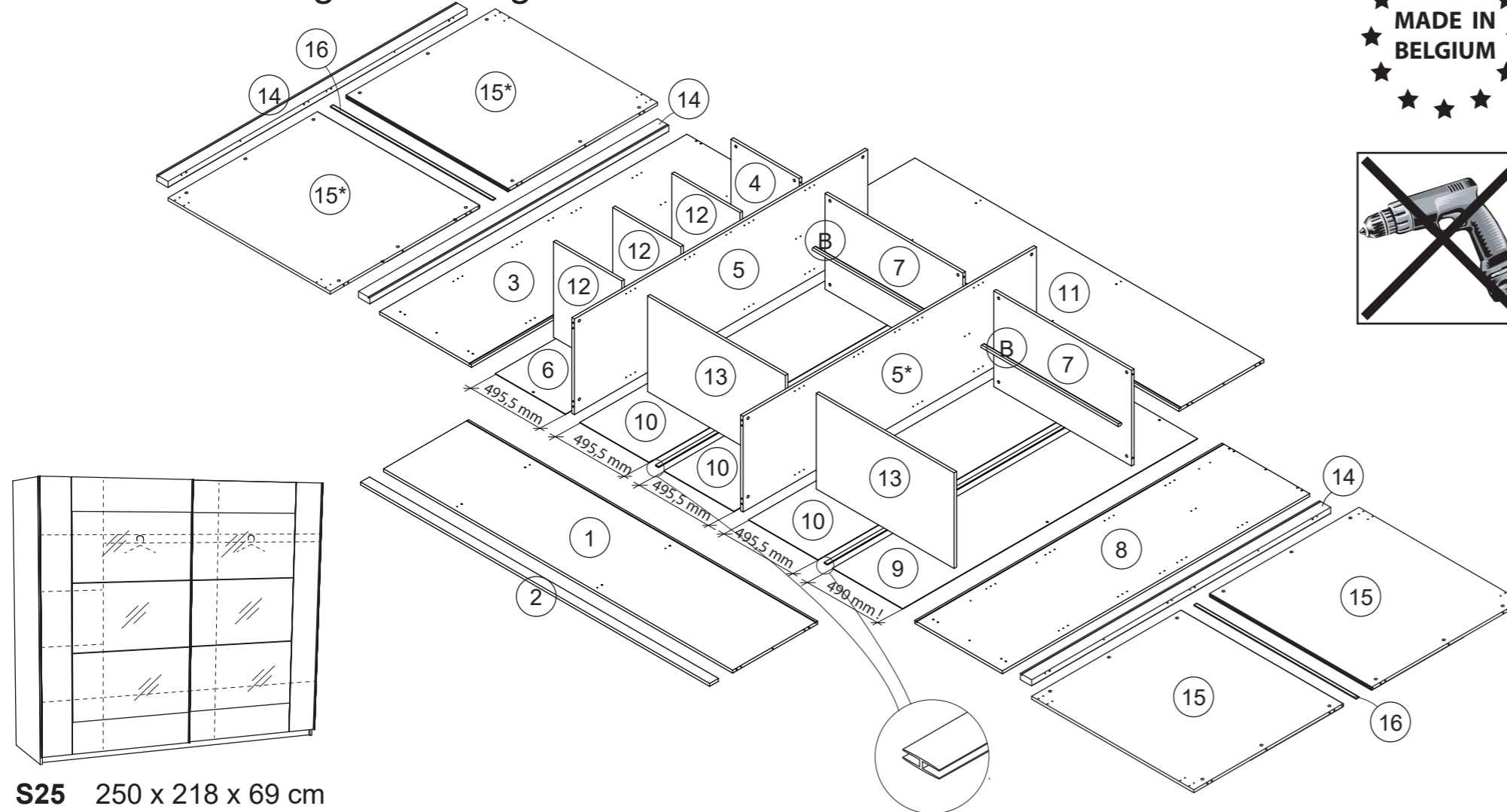
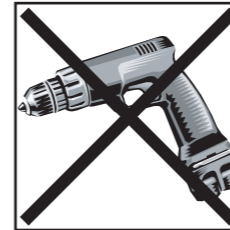

S25 250 x 218 x 69 cm

Hettich 9242738

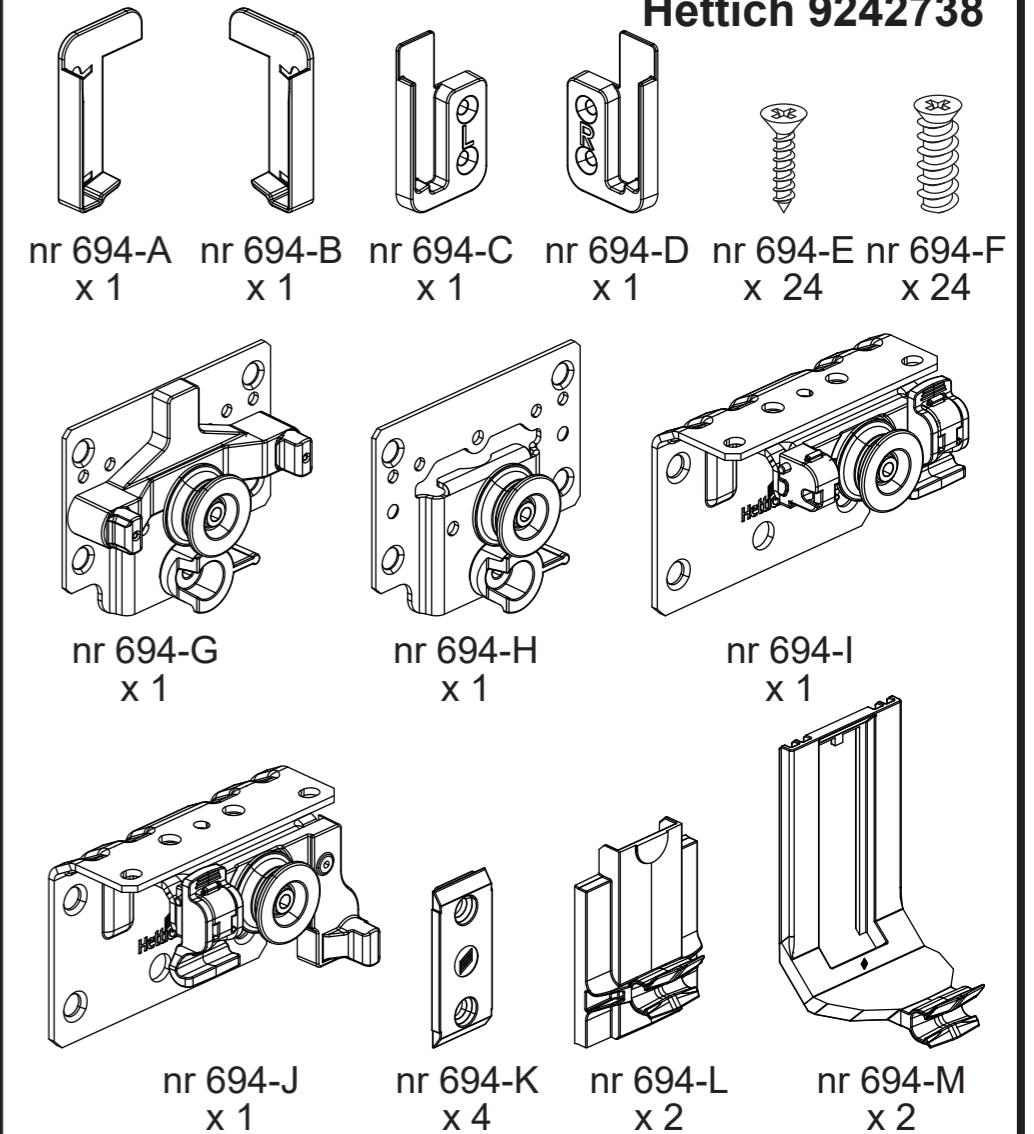

Hettich 9242219

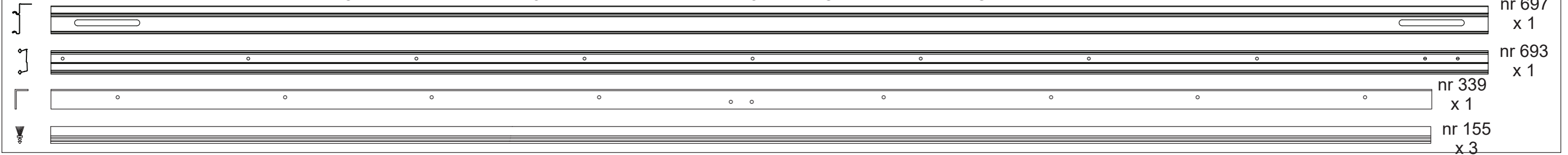
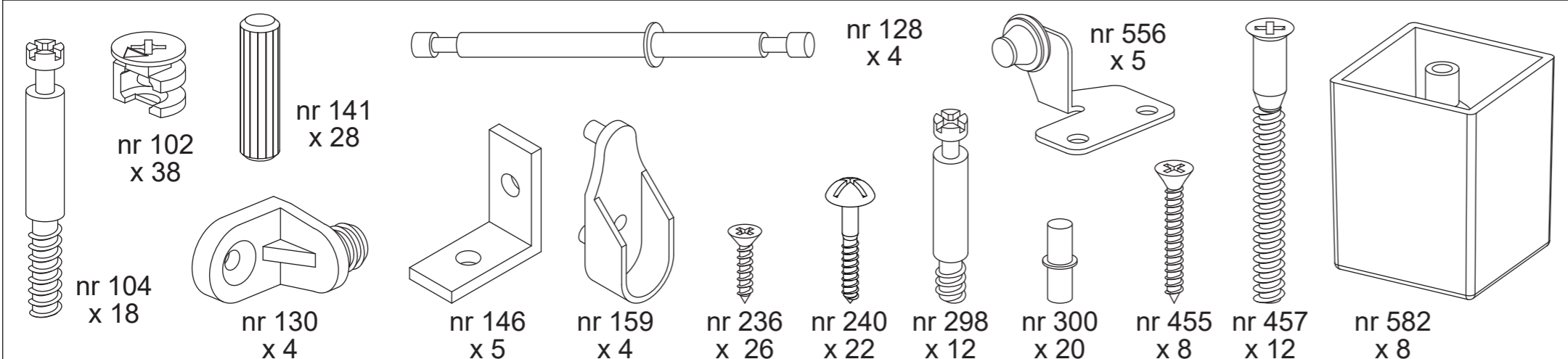
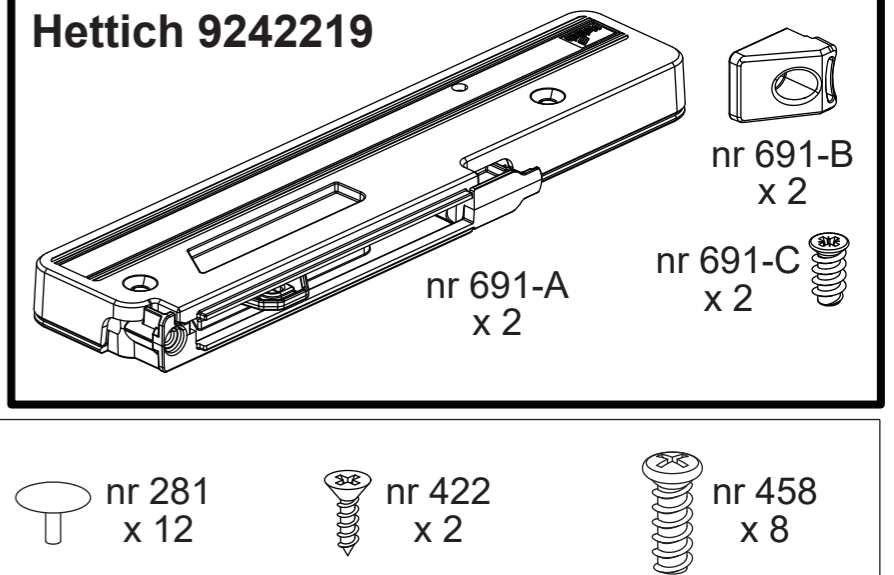

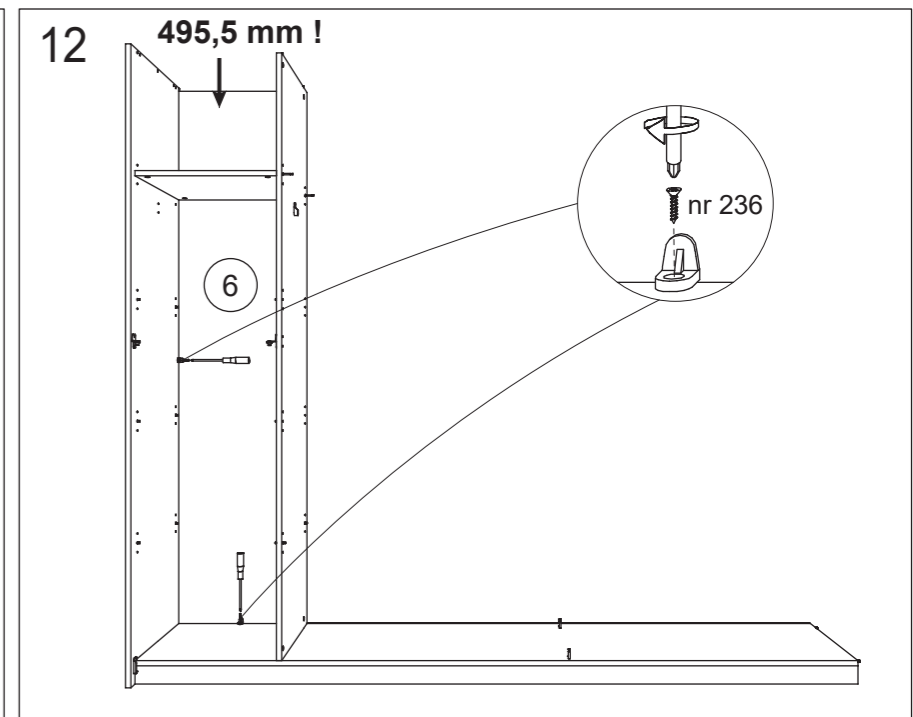
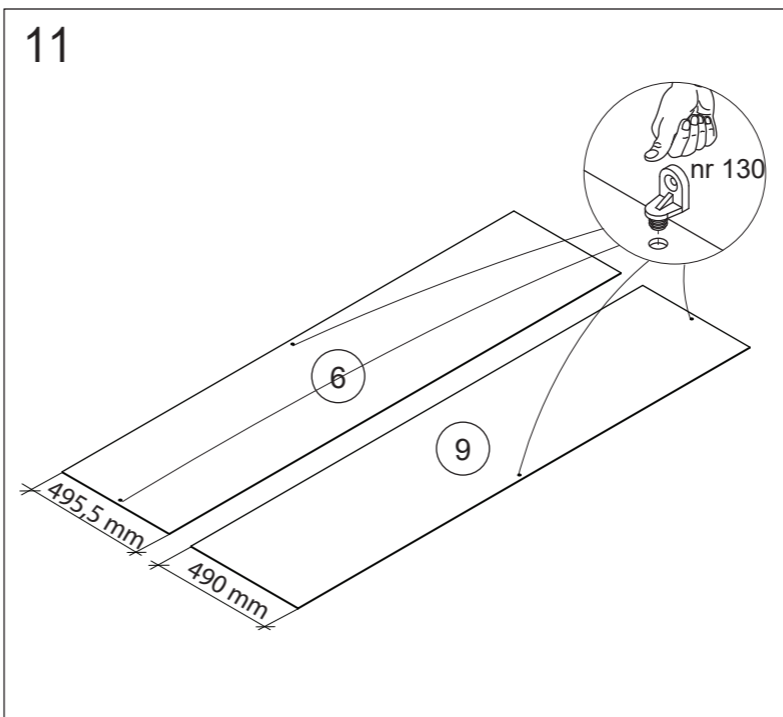
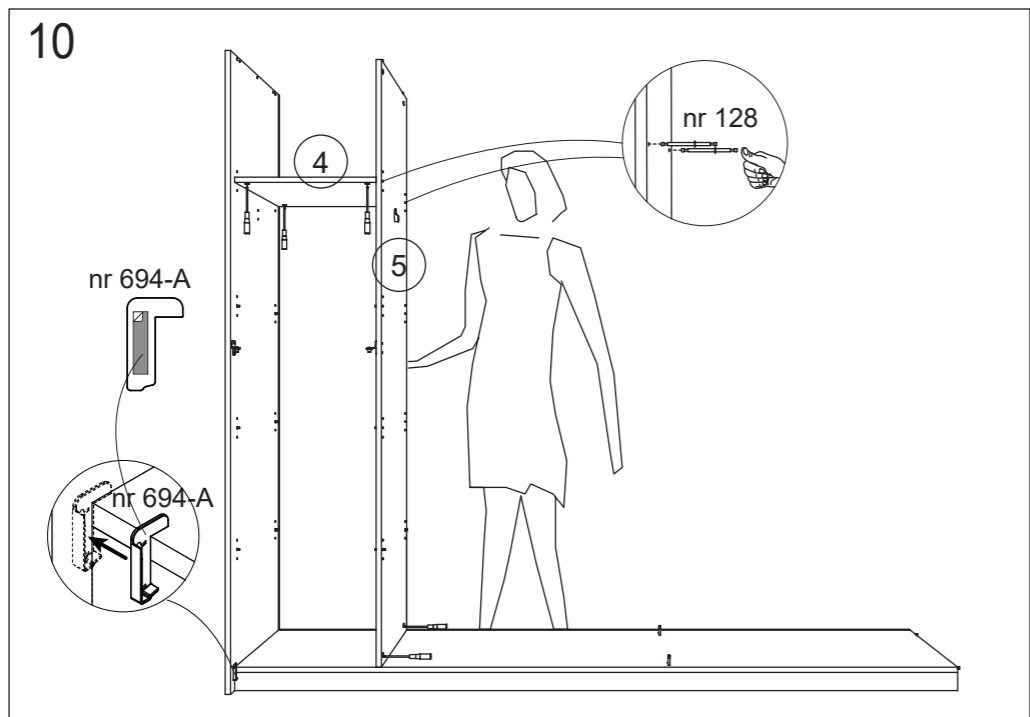
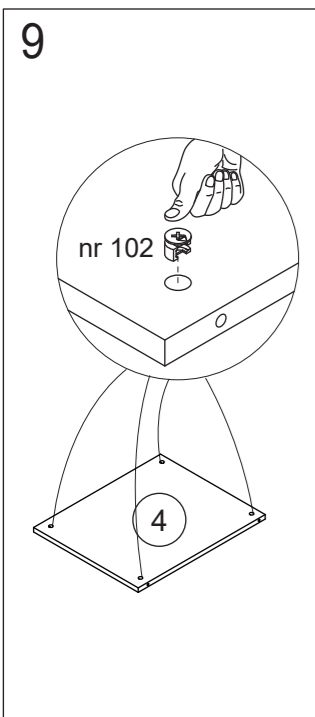
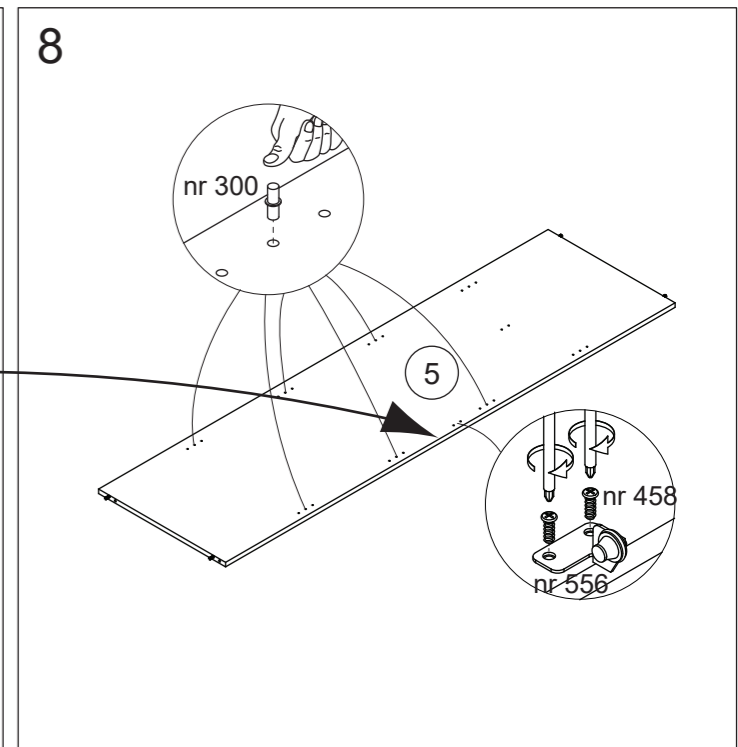
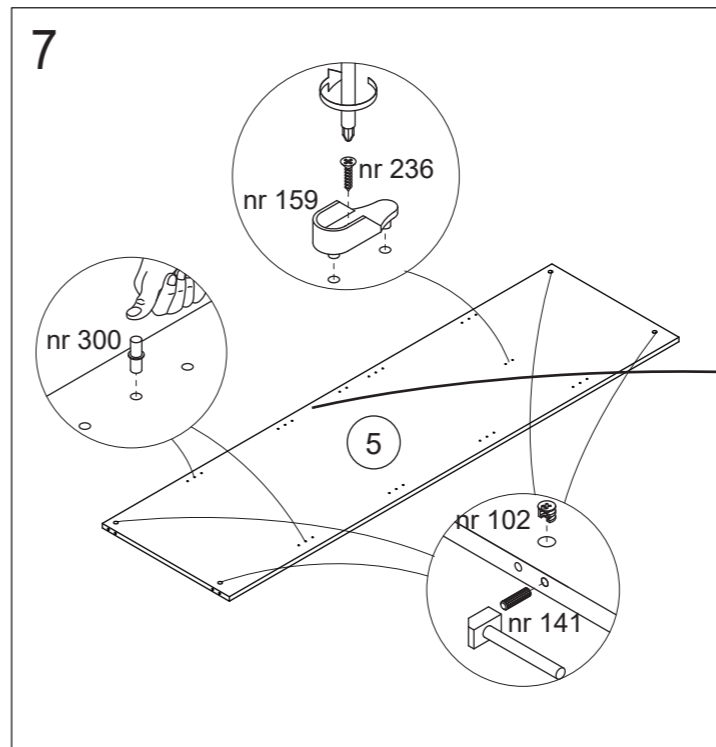
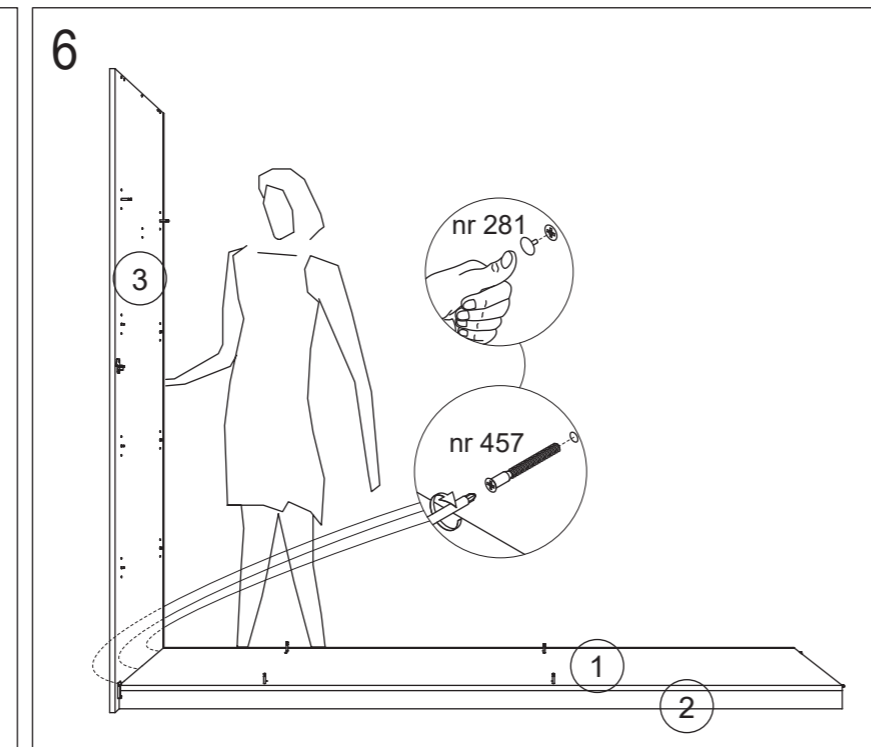
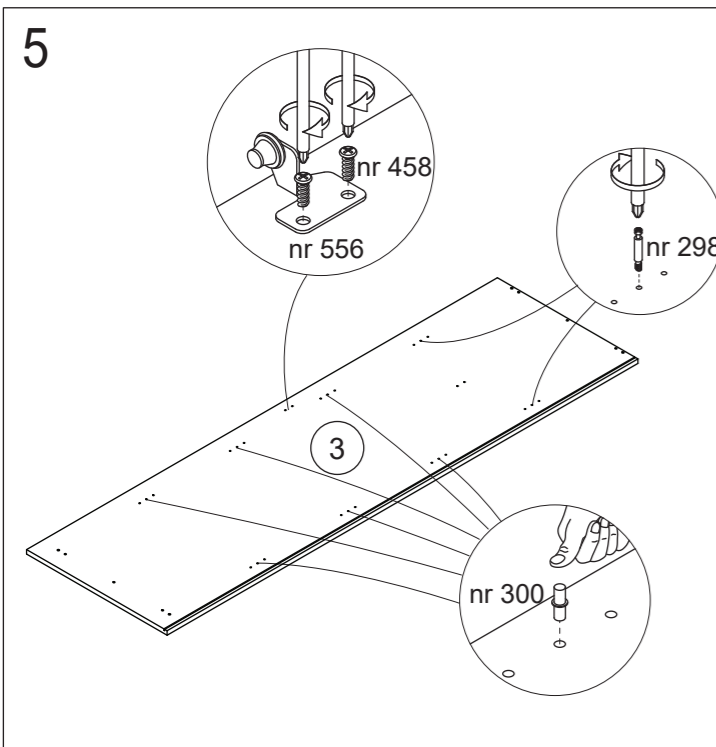
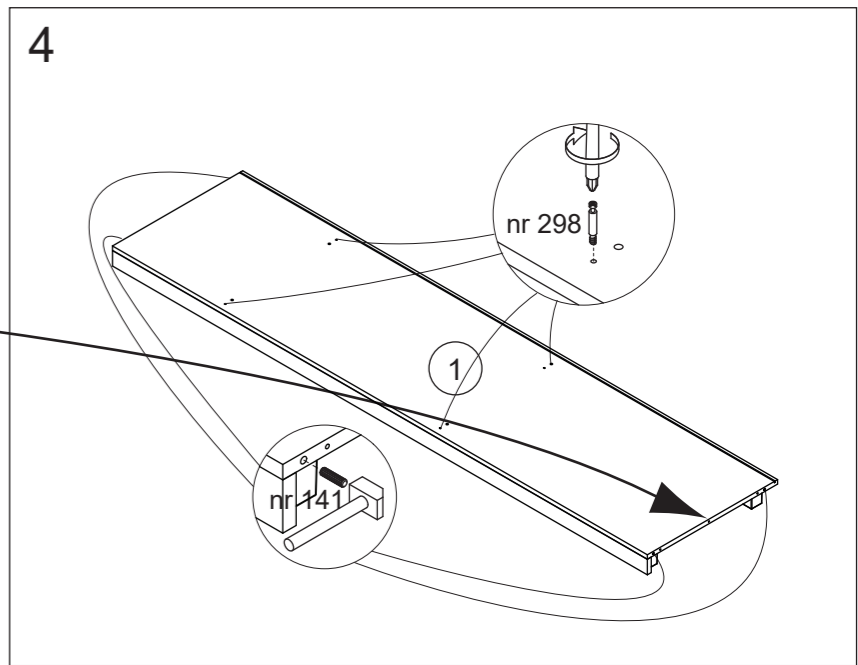
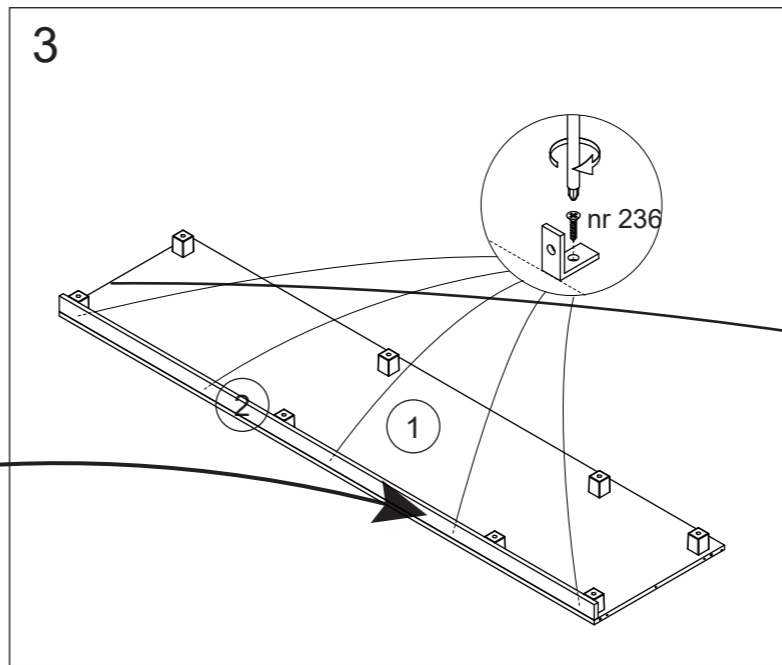
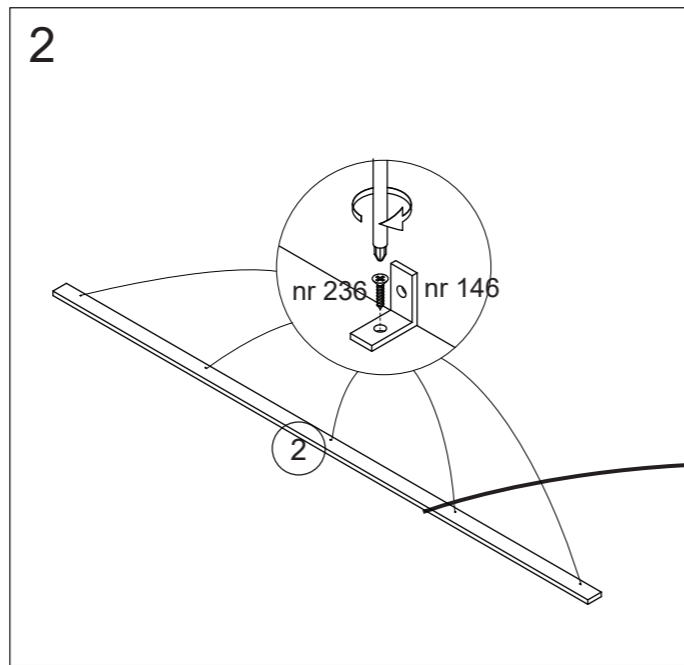
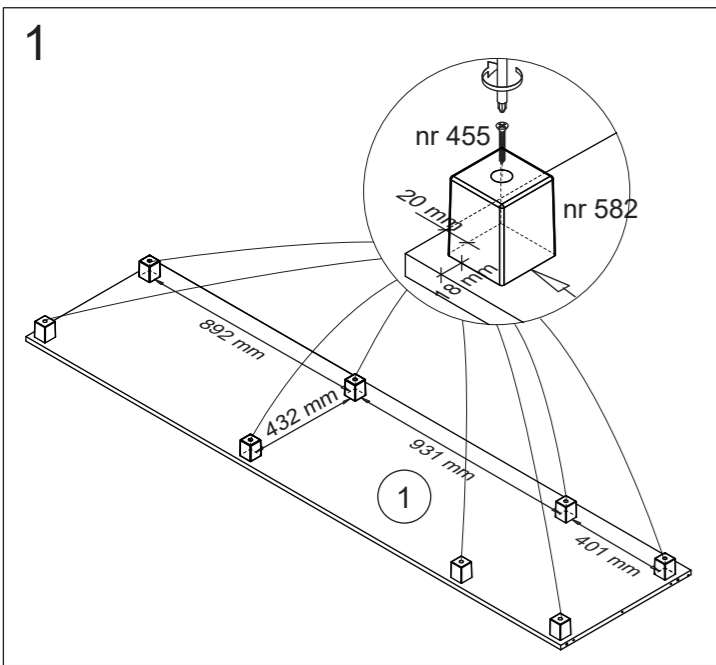

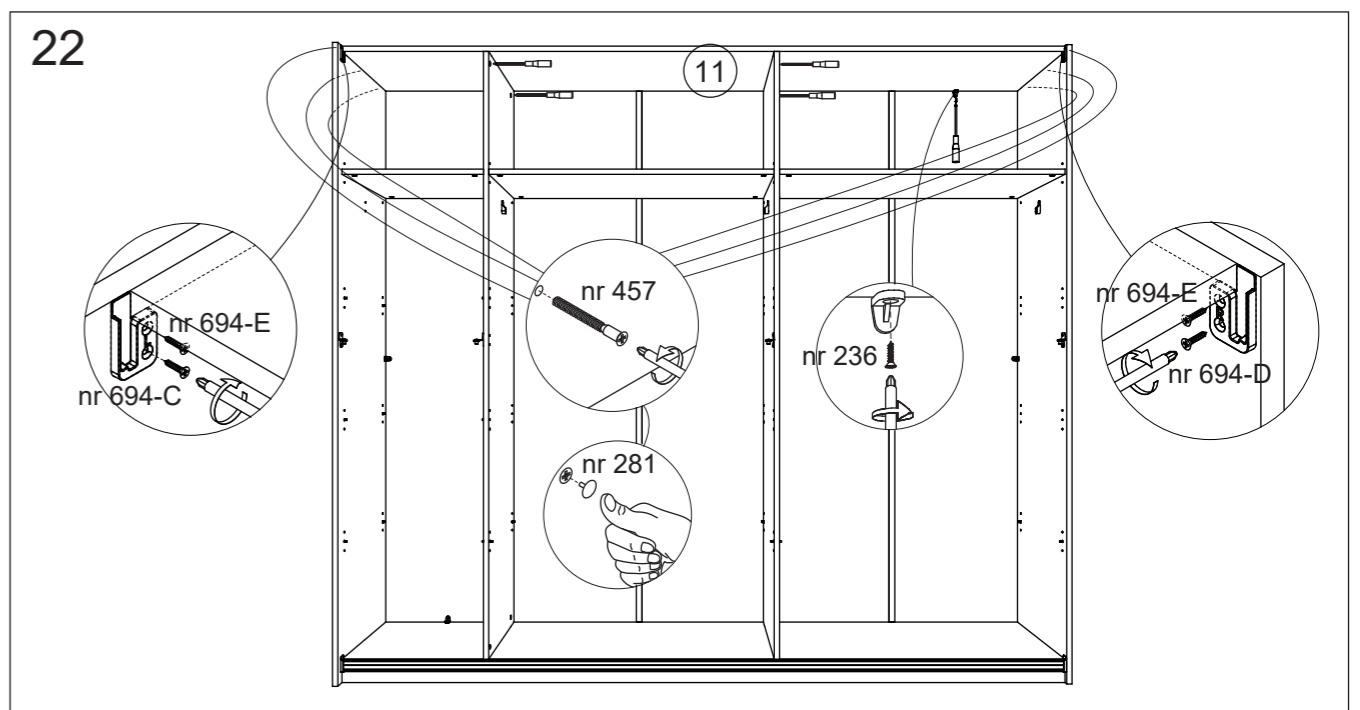
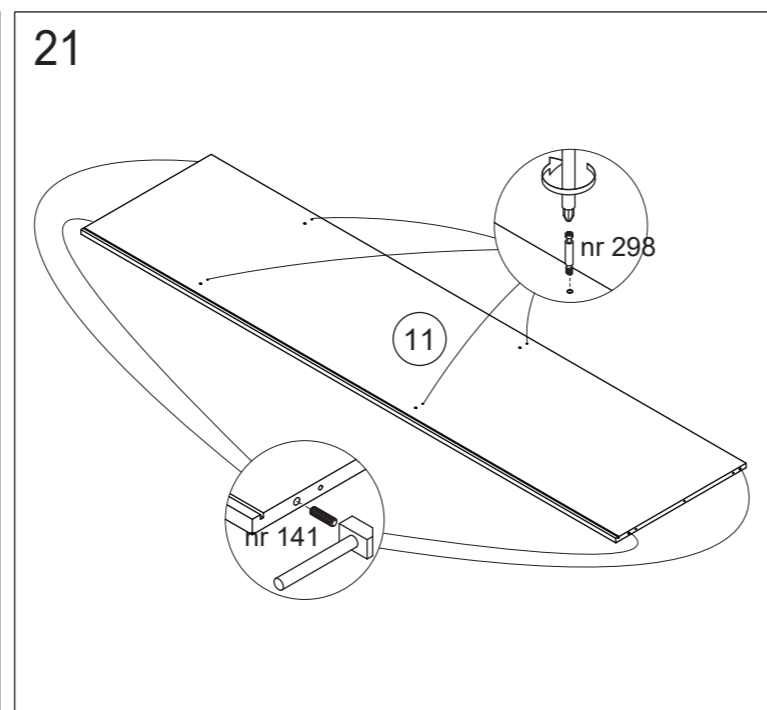
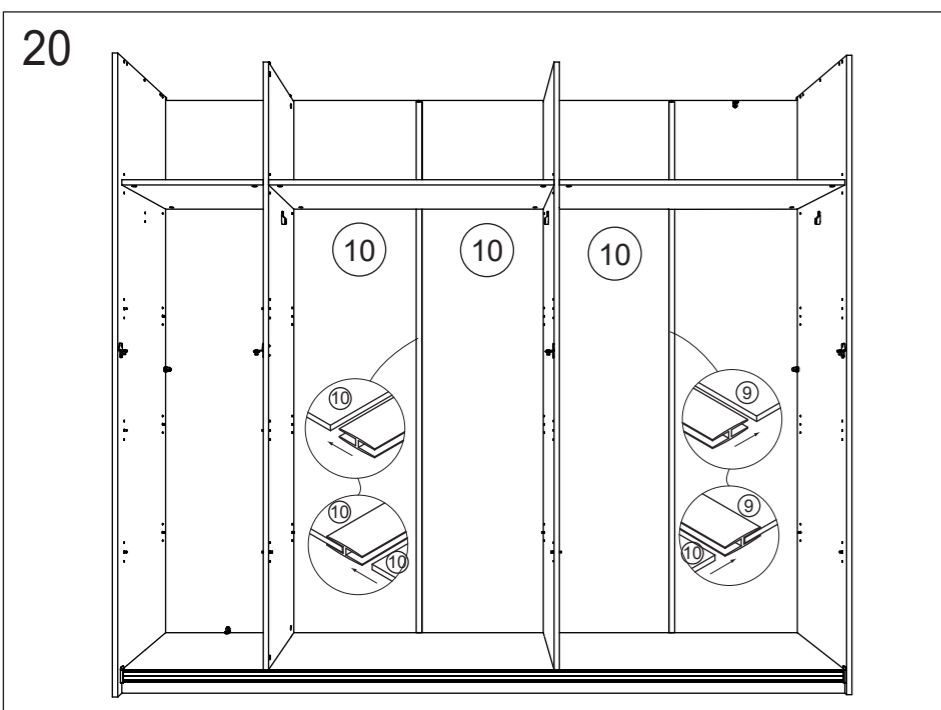
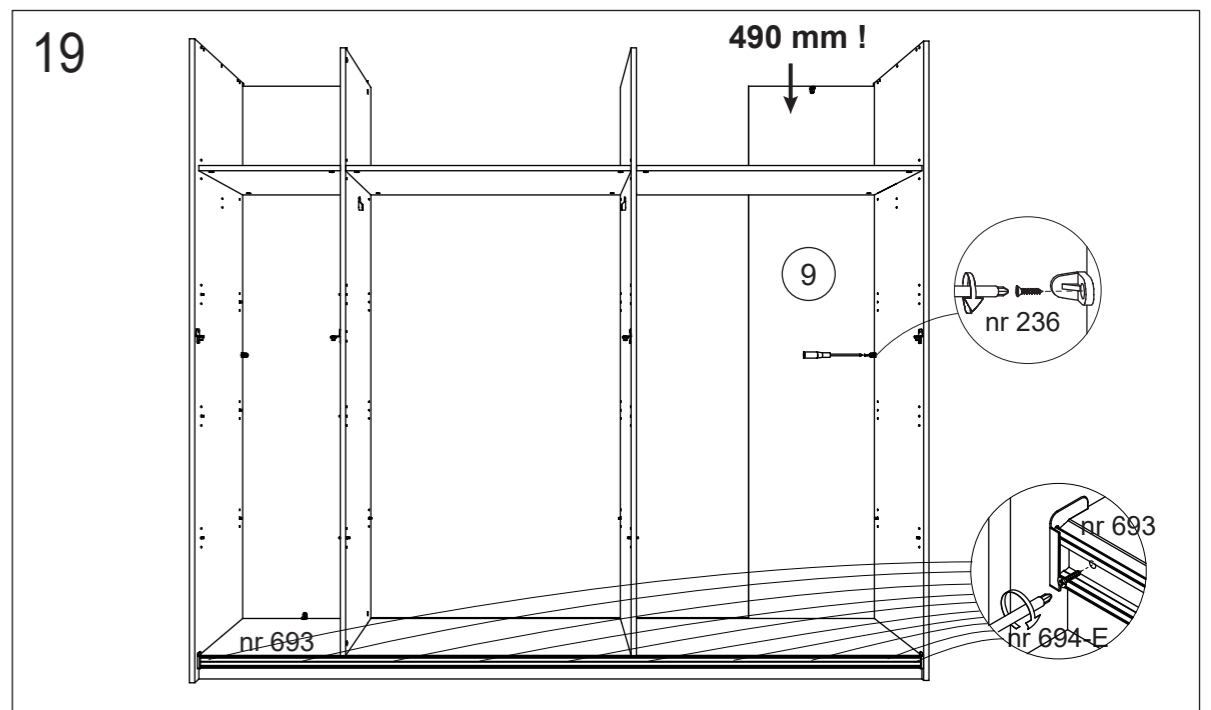
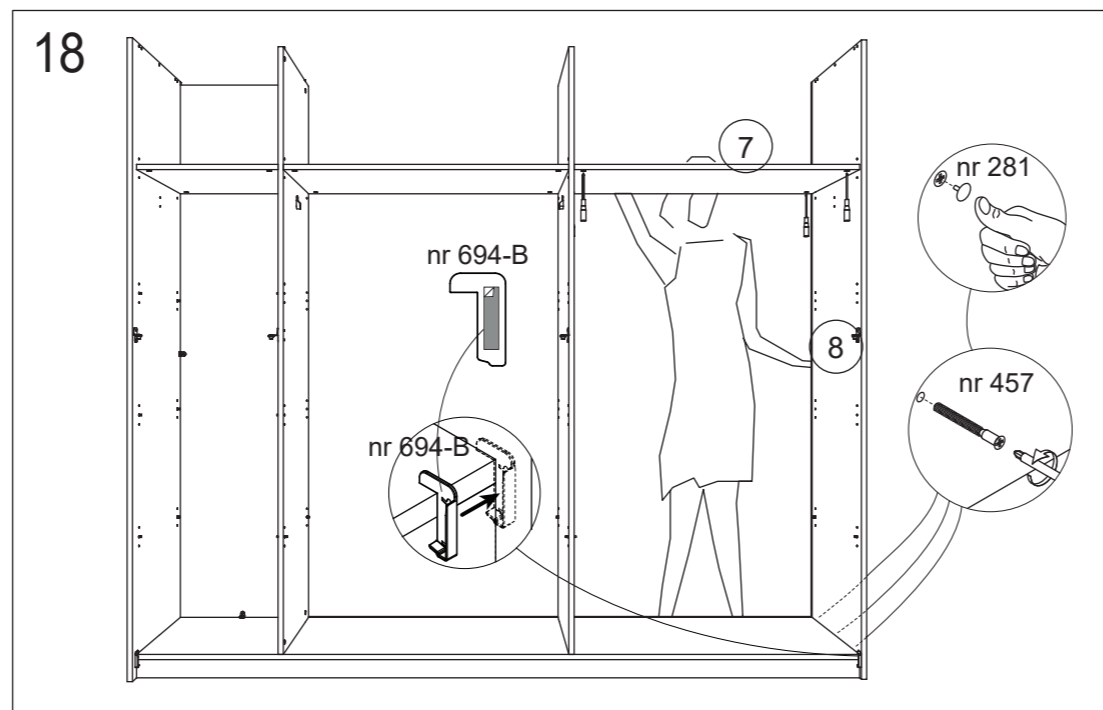
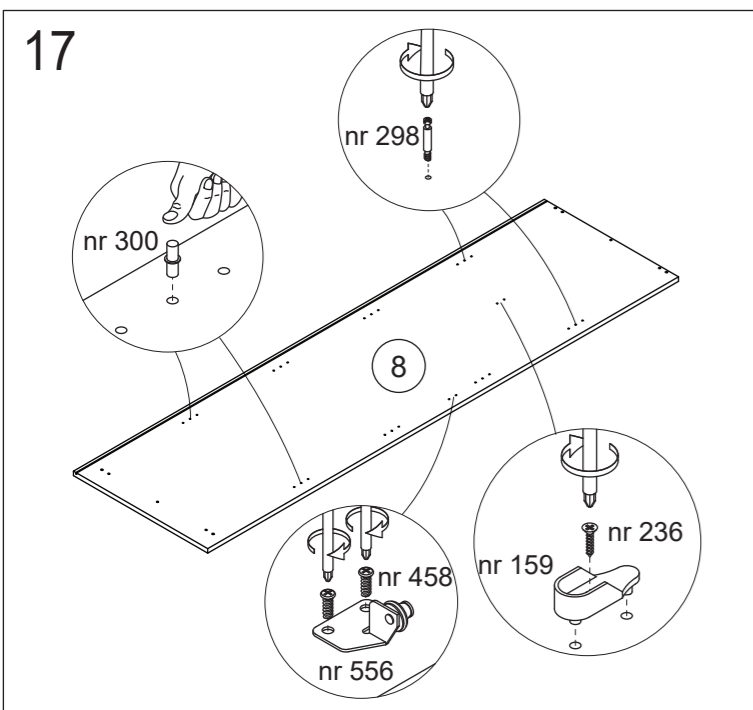
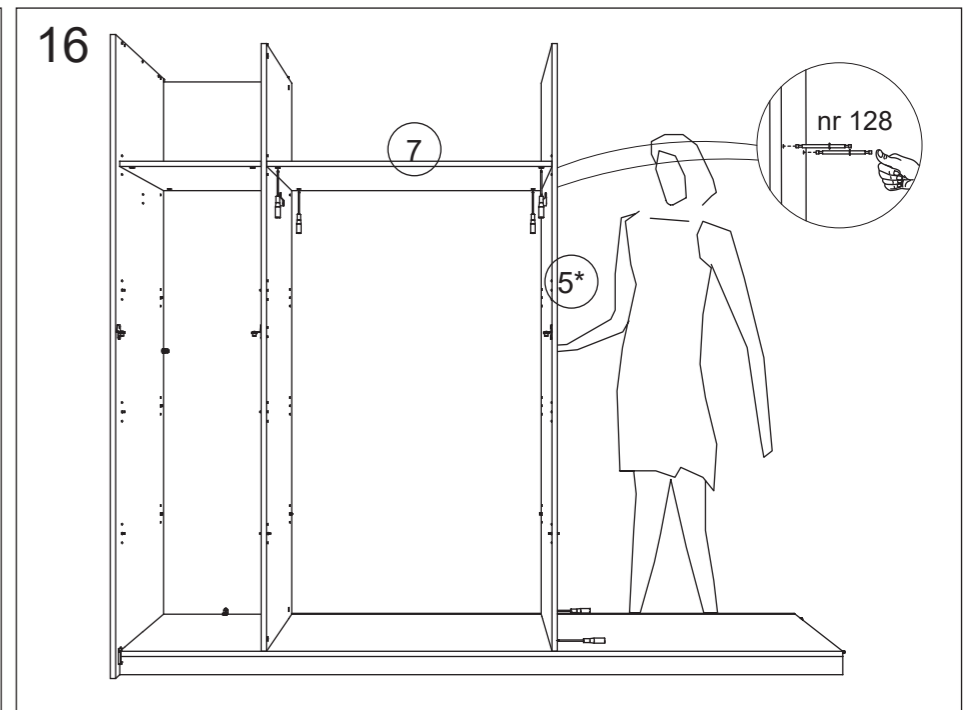
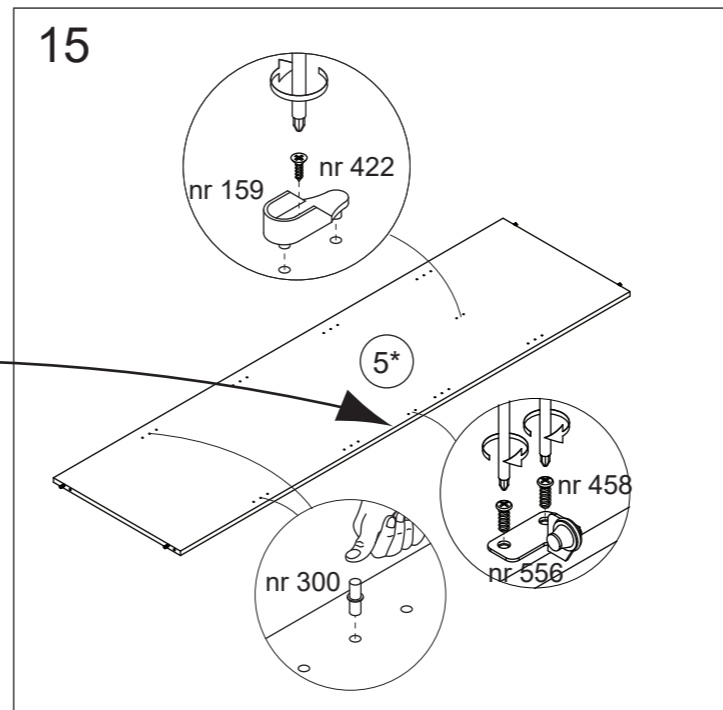
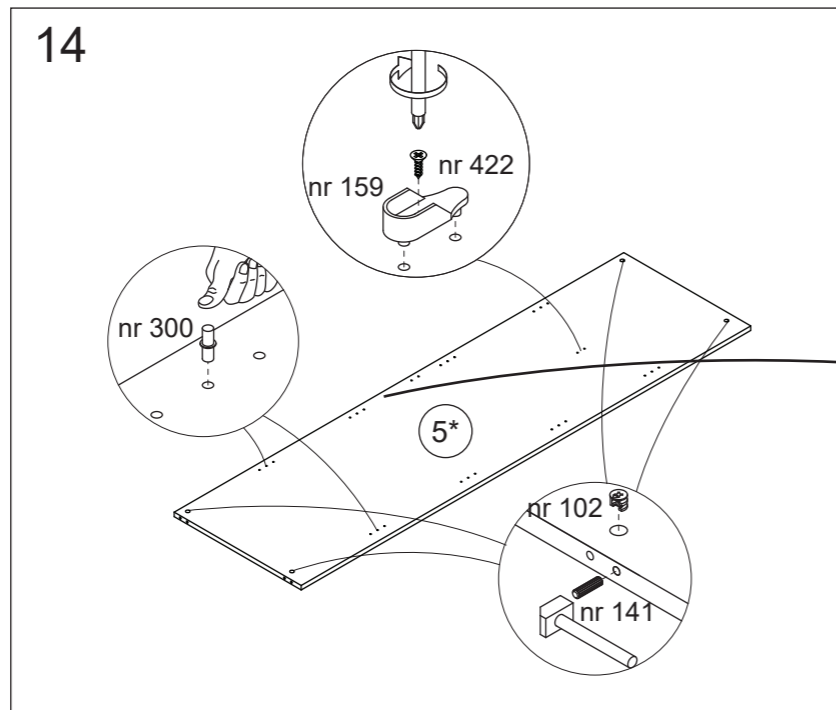
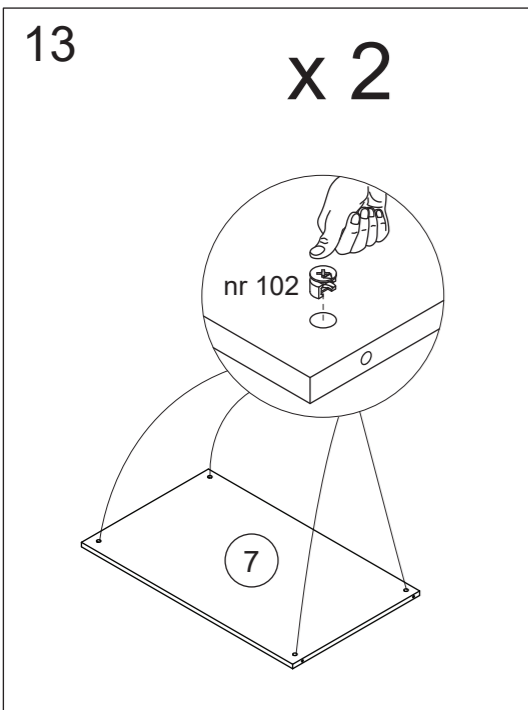

23

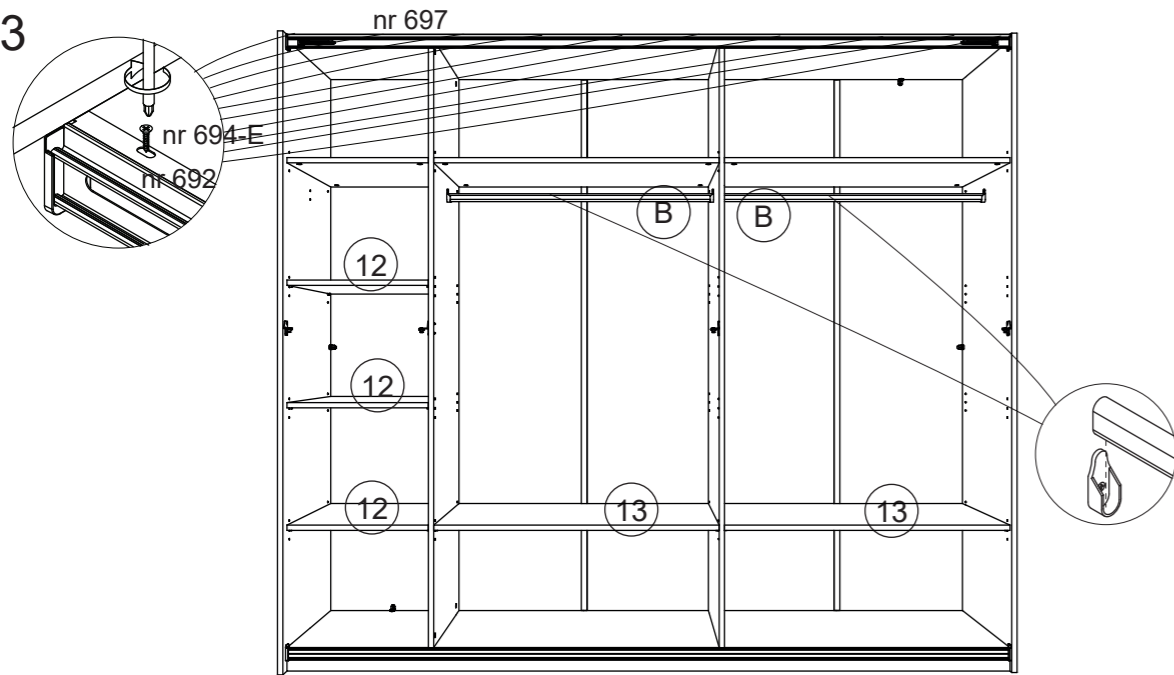

24

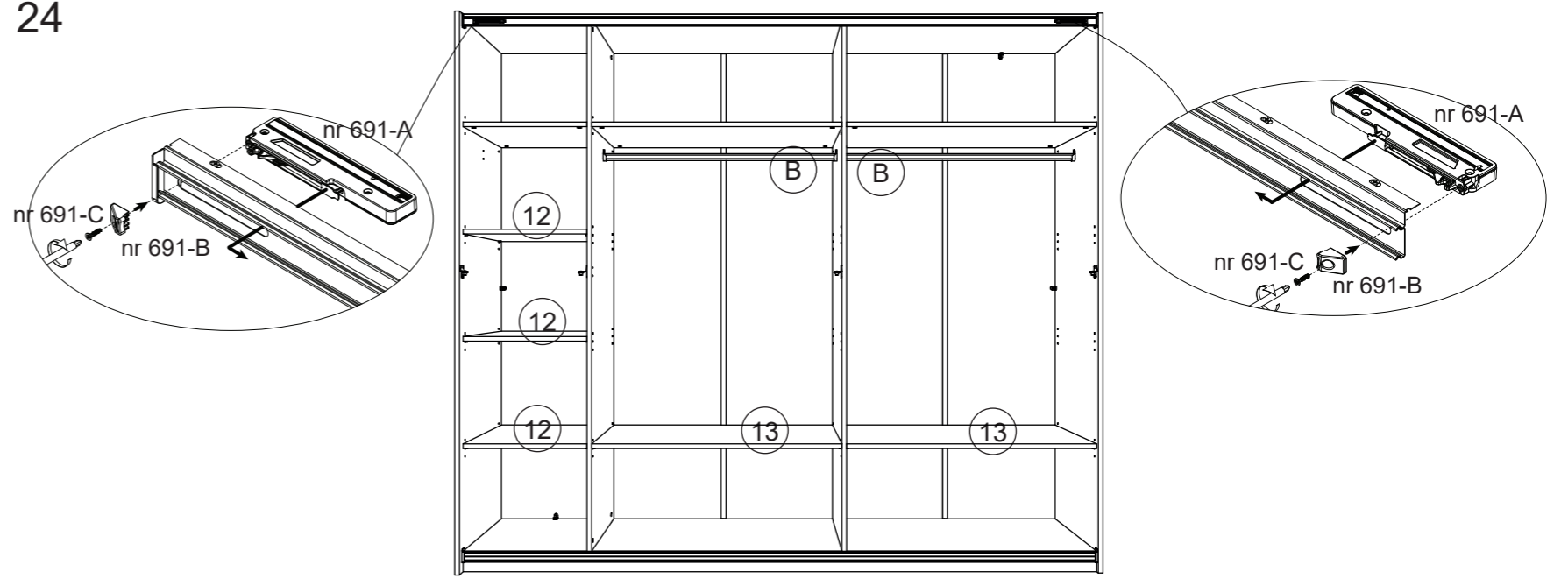

25

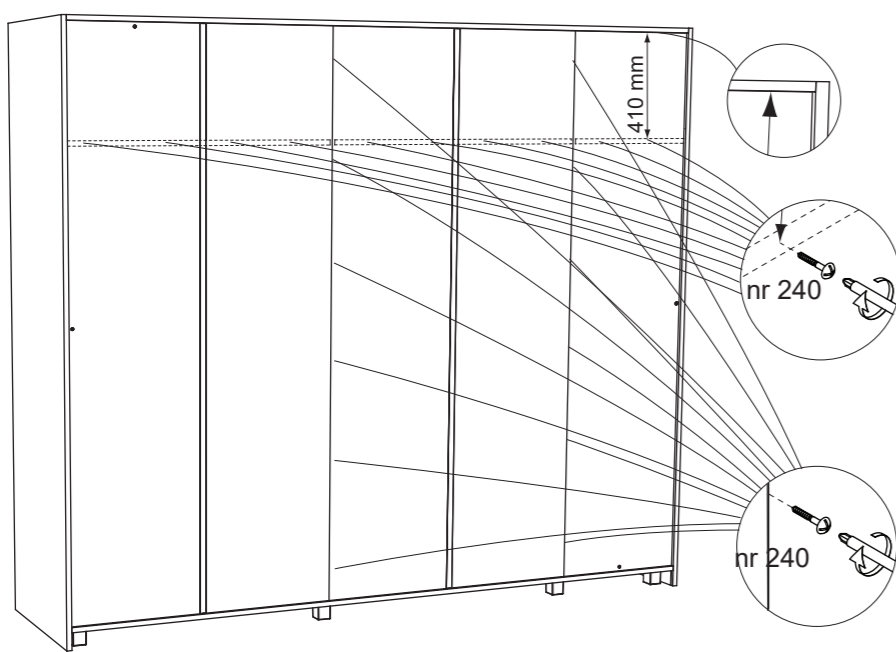

Voor de regeling van het sluiten van de deuren, moet u nu de kast goed waterpas zetten.

Pour le règlement de fermeture des portes, il faut mettre l'armoire de niveau maintenant.

To adjust the closing of the doors, you have to put the robe at level now.

Der Schrank soll jetzt waagrecht stehen, für die Regelung des Schliessens der Türe

26

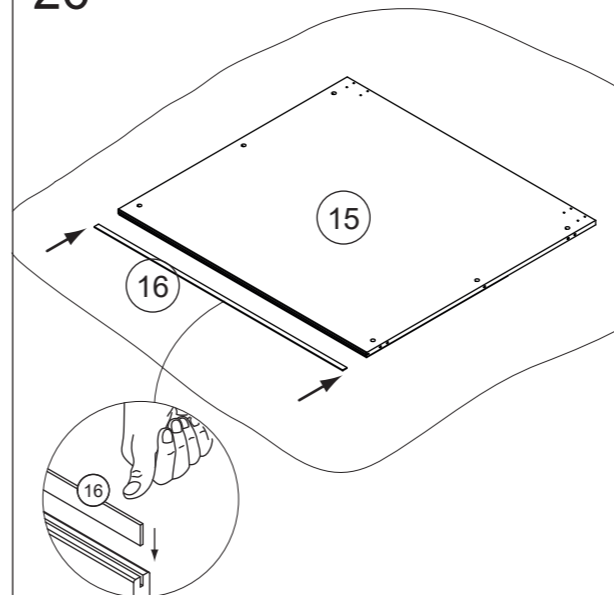

27

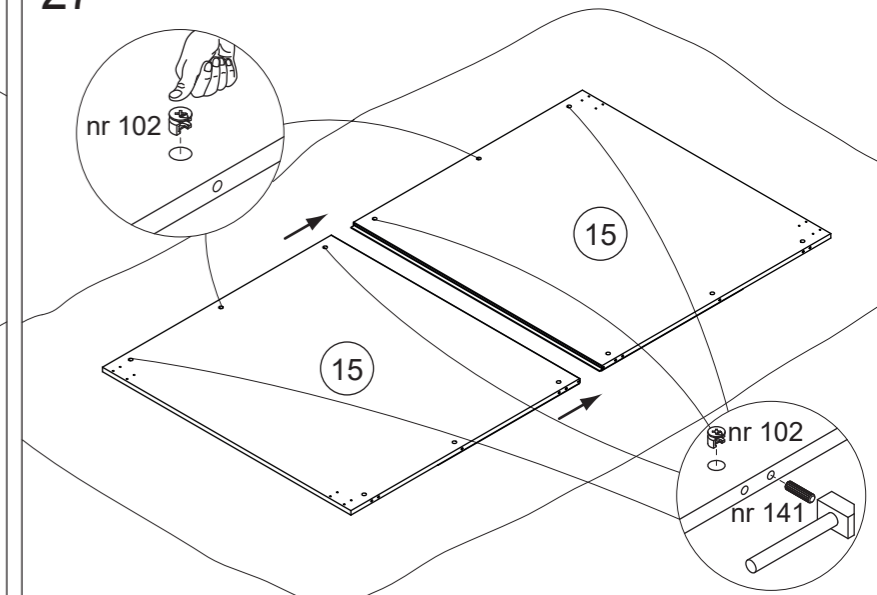

28

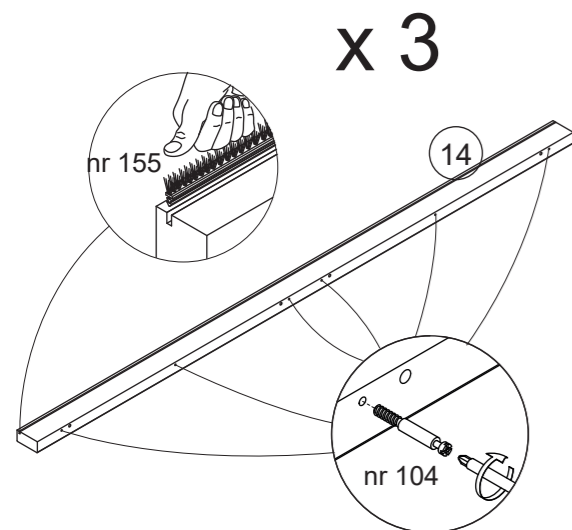

29

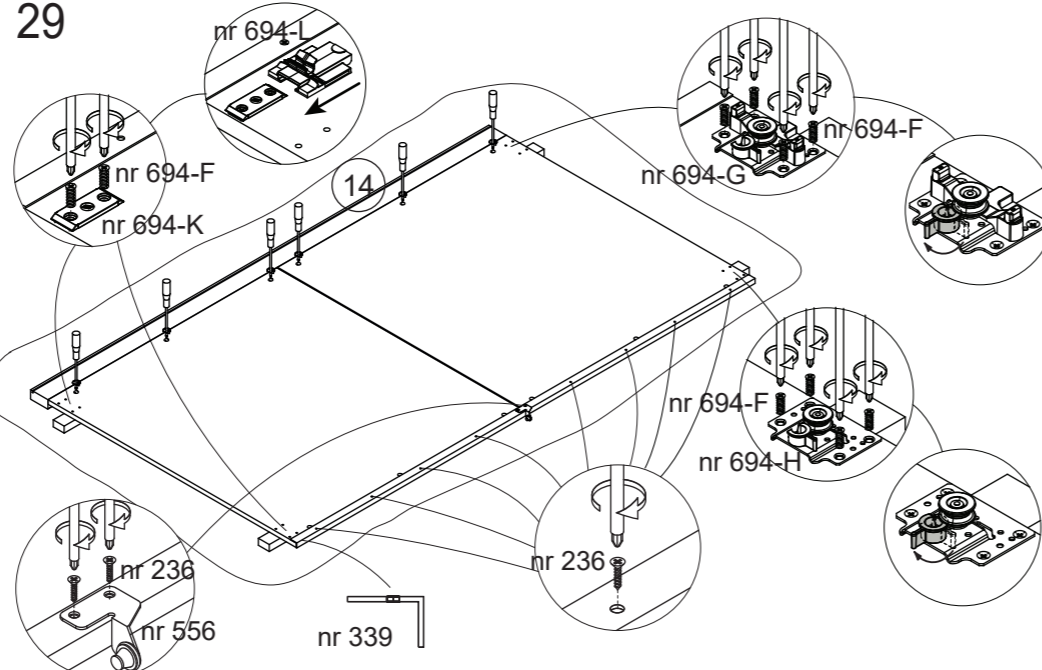

30

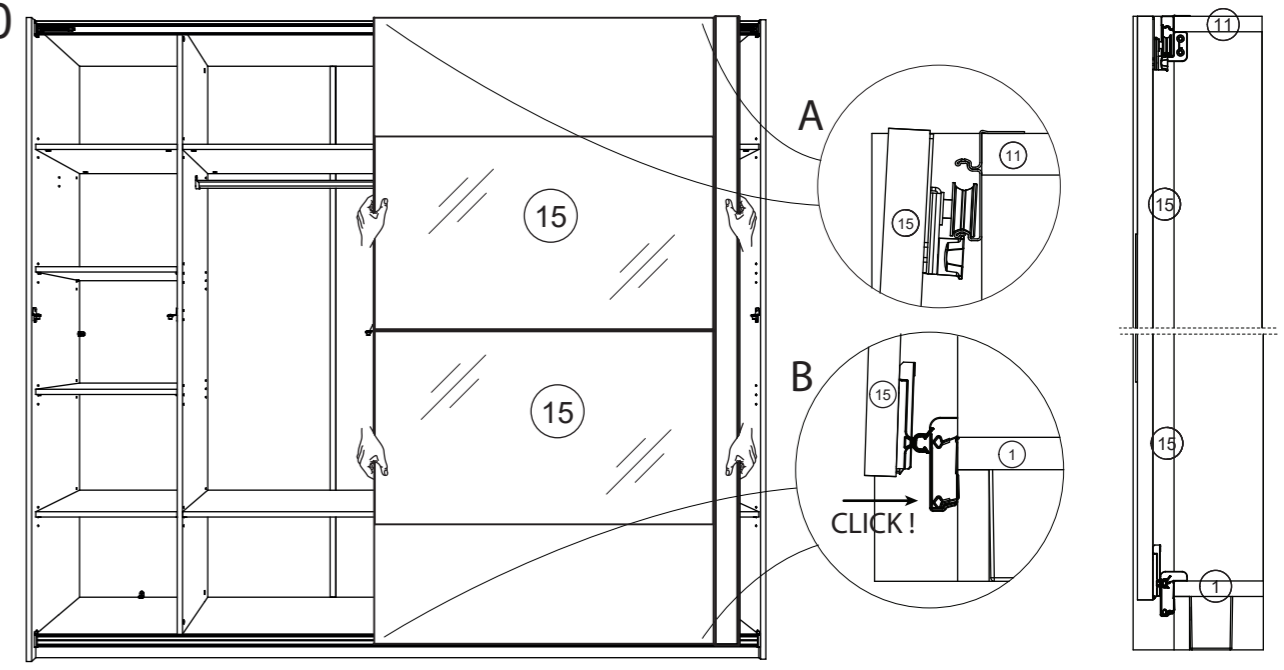

31

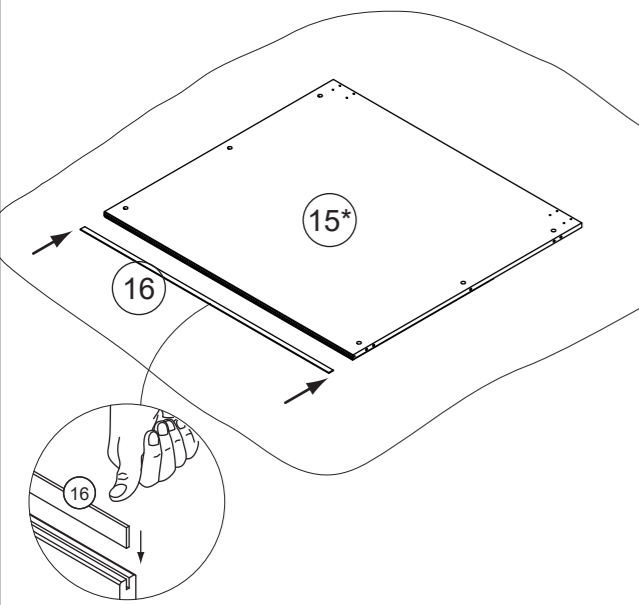

32

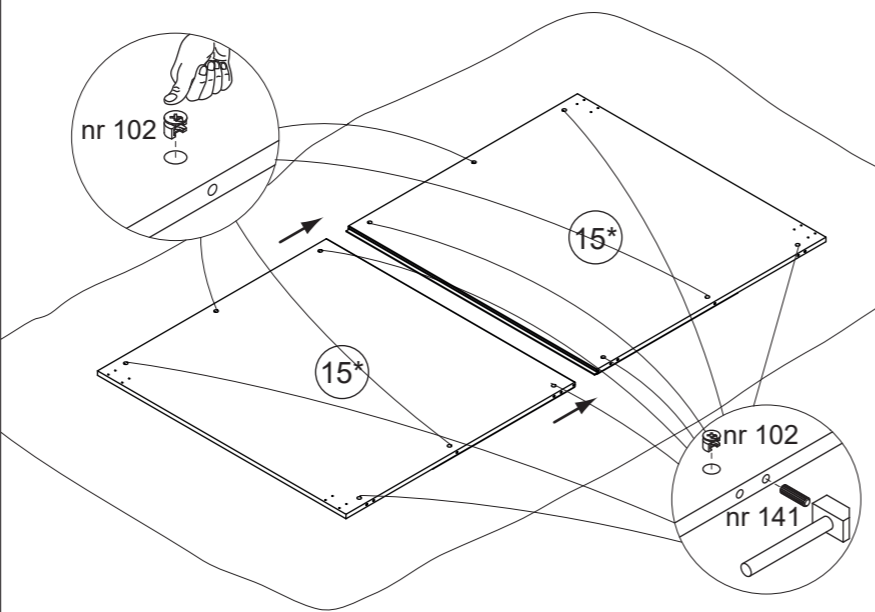

33

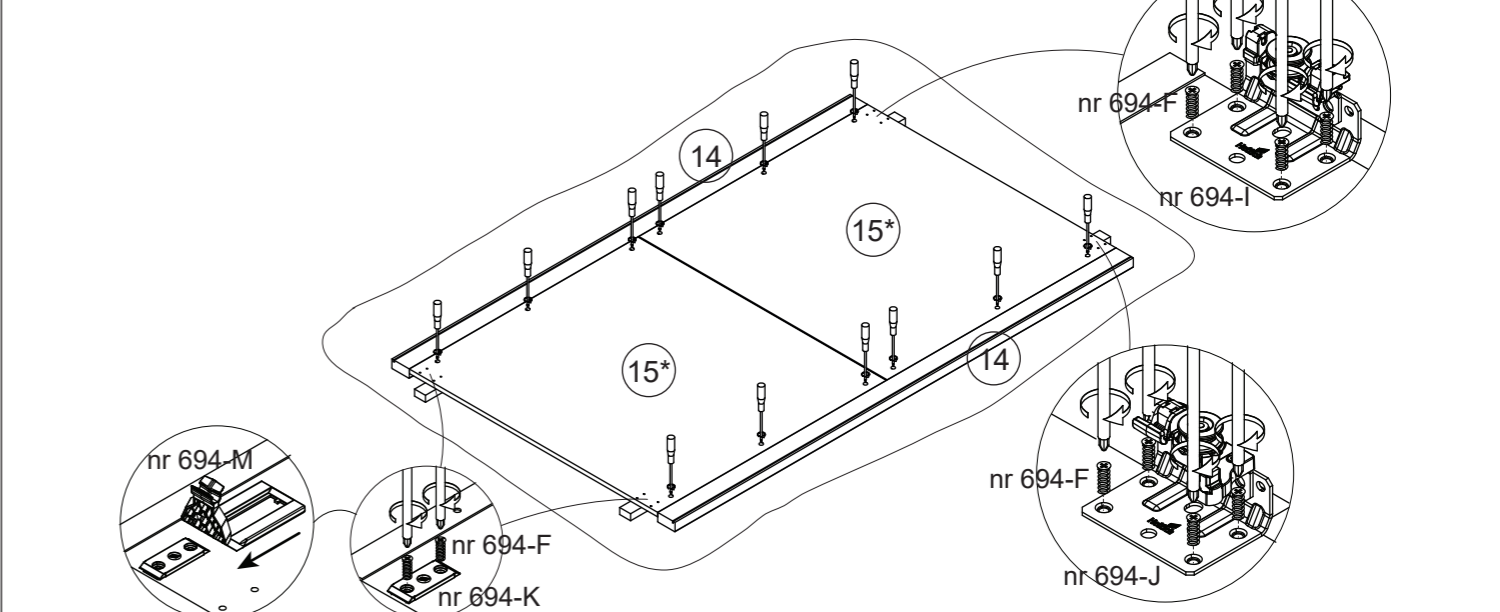

34

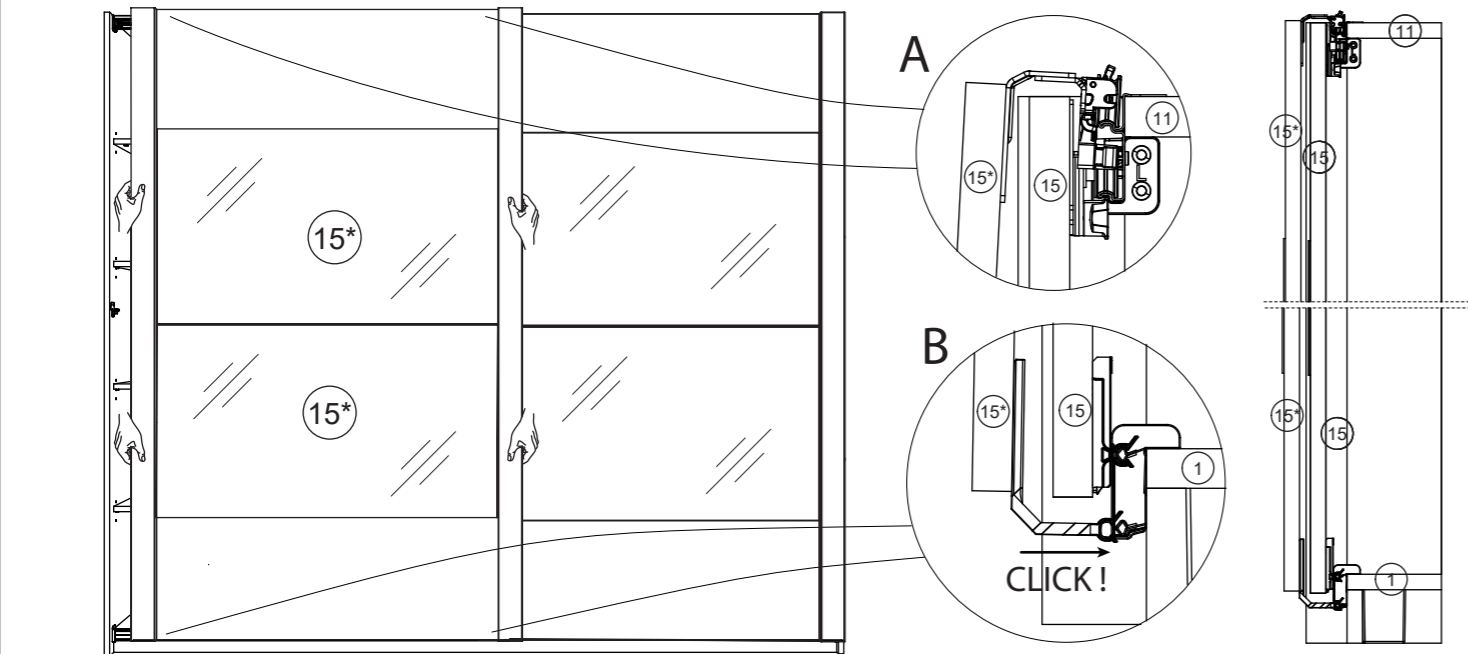

35

