



i-PILOT®

Owner's Manual

INTRODUCTION

THANK YOU

Thank you for purchasing the Minn Kota® i-Pilot®. This revolutionary control system uses GPS technology to record and store tracks and locations which are then used to deliver unprecedented levels of boat control. Intuitive features and wireless control help to accurately position your boat and improve your bait presentation. i-Pilot navigates and positions your boat for you, so you can focus on fishing.

REGISTRATION

Remember to keep your receipt and immediately register your trolling motor. A registration card is included with your motor or you can complete registration on our website at minnkotamotors.com.

SERIAL NUMBER

Your Minn Kota 11-character serial number is very important. It helps to determine the specific model and year of manufacture. When contacting Consumer Service or registering your product, you will need to know your product's serial number. We recommend that you write the serial number down so that you have it available for future reference.

NOTICE: The location of the serial number, for the i-Pilot navigation system, is different based on the motor it is installed on. The motor serial number encompasses the i-Pilot navigation system. Refer to the images to the right to determine location based on motor model.

PRODUCT INFORMATION (For Consumer Reference Only)

Model: _____

Serial Number: _____

Purchase Date: _____

Store Where Purchased: _____

NOTICE: Do not return your Minn Kota product to your retailer. Your retailer is not authorized to repair or replace this unit. You may obtain service by: calling Minn Kota at (800) 227-6433; returning your product to the Minn Kota Factory Service Center; sending or taking your product to any Minn Kota authorized service center. A list of authorized service centers is available on our website, at minnkotamotors.com. Please include proof of purchase, serial number and purchase date for warranty service with any of the above options.

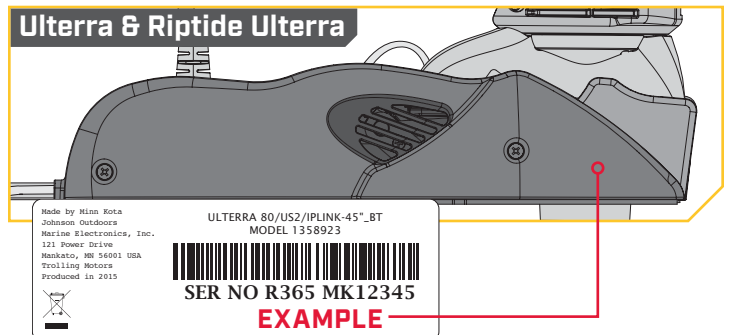
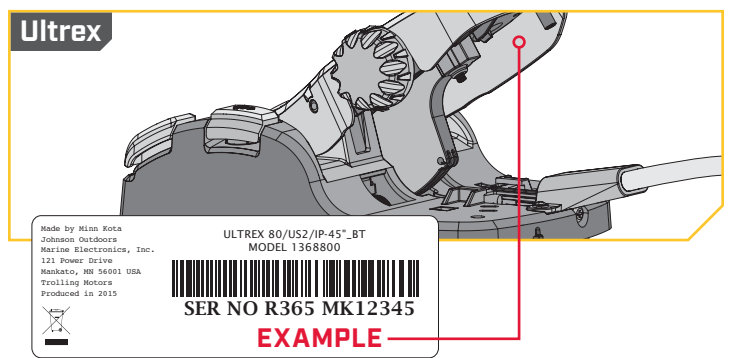
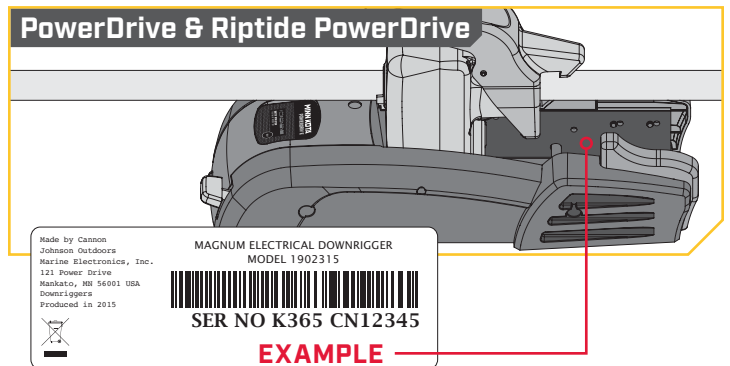
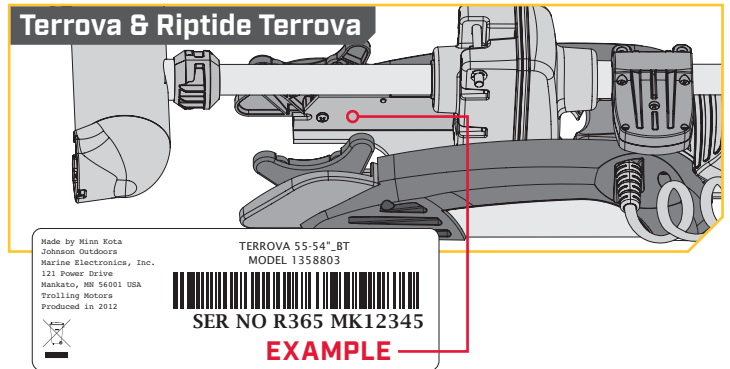

TABLE OF CONTENTS

SAFETY CONSIDERATIONS	4
WARRANTY	5
FEATURES	6
REMOTE BUTTONS	7
HEADER & ICONOGRAPHY	8
DISPLAY SCREEN	9
GETTING STARTED	10
The i-Pilot System	10
System Startup.....	11
AUDIO MODES	13
Audio Mode Control	13
SPOT-LOCK	15
How Spot-Lock Works	15
Spot-Lock Functions.....	15
CRUISE CONTROL	18
i-Pilot with Cruise Control.....	18
Working with Cruise Control.....	19
HIGH SPEED BYPASS	21
Motor Speed and High Speed Bypass	21
Controlling High Speed Bypass	21
AUTOPILOT	23
i-Pilot with Autopilot.....	23
AutoPilot Modes	23
Working with AutoPilot.....	24
iTRACKS	26
Understanding iTracks.....	26
Working with iTracks	27
iTrack Arrival Modes.....	29
HEADING SENSOR	30
Heading Sensor Features.....	30
Heading Sensor Functions.....	30
Light Patterns	30
Installation.....	31
Working with the Heading Sensor.....	37
MOTOR CONTROLS	41
TALON CONTROLS	46
REMOTE CONTROLS	53
i-PILOT APP	63
Launching the App & Demo Mode.....	66
Getting Started.....	67
SERVICE & MAINTENANCE	71
Battery Replacement	71
i-Pilot Software.....	72
Pairing a Remote with a Controller	73
Talon Control	75
General Maintenance	77
Troubleshooting.....	78
COMPLIANCE STATEMENTS	79
PARTS DIAGRAM & PARTS LIST	81
NOTES	85

SAFETY CONSIDERATIONS

Please thoroughly read the user manual. Follow all instructions and heed all safety and cautionary notices. Use of this product is only permitted for persons that have read and understood these user instructions. Minors may use this product only under adult supervision.

WARNING

You are responsible for the safe and prudent operation of your vessel. We have designed your Minn Kota product to be an accurate and reliable tool that will enhance boat operation and improve your ability to catch fish. This product does not relieve you from the responsibility for safe operation of your boat. You must avoid hazards to navigation and always maintain a permanent watch so you can respond to situations as they develop. You must always be prepared to regain manual control of your boat. Learn to operate your Minn Kota product in an area free from hazards and obstacles.

CAUTION

This unit uses a magnetic compass to detect direction of travel. The compass can be adversely affected by magnets or large, ferrous metal objects near (within 24" of) the trolling motor control head.

Obstructions on the propeller may cause excessive vibration of the motor head. This vibration can cause the compass to wander and erratic steering to occur. Clear the obstruction to return the motor to normal operation.

WARNING

It is recommended to only use Johnson Outdoors approved accessories with your Minn Kota motor, such as this i-Pilot system. Using non-approved accessories including to mount or control your motor may cause damage, unexpected motor operation and injury. Be sure to use the product and approved accessories, including remotes, safely and in the manner directed to avoid accidental or unexpected motor operation. Keep all factory installed parts in place including motor and accessory covers, enclosures and guards.

WARNING

When the motor is being controlled by the i-Pilot navigation system, the Controller will continue to perform the last task it was assigned, even when the remote is not powered on. Be sure to know how to power the motor "on" and "off", and always be alert for unexpected motor movement, such as a turning propeller, even when the remote is powered "off". Refer to the Owner's Manual for how to control the motor without the i-Pilot remote and become familiar with it's features including how to turn it "on" and "off".

WARRANTY

WARRANTY ON MINN KOTA I-PILOT® AND I-PILOT® LINK™ WIRELESS GPS TROLLING SYSTEM ACCESSORY

Johnson Outdoors Marine Electronics, Inc. ("JOME") extends the following limited warranty to the original retail purchaser only. Warranty coverage is not transferable.

Minn Kota Limited Two-Year Warranty on the Entire Product

JOME warrants to the original retail purchaser only that the purchaser's new Minn Kota i-Pilot® or i-Pilot® Link™ Wireless GPS Trolling System Accessory will be materially free from defects in materials and workmanship appearing within two (2) years after the date of purchase. JOME will (at its option) either repair or replace, free of charge, any parts found by JOME to be defective during the term of this warranty. Such repair, or replacement shall be the sole and exclusive liability of JOME and the sole and exclusive remedy of the purchaser for breach of this warranty.

Exclusions & Limitations

This limited warranty does not apply to products that have been used commercially or for rental purposes. This limited warranty does not cover normal wear and tear, blemishes that do not affect the operation of the product, or damage caused by accidents, abuse, alteration, modification, shipping damages, negligence of the user or misuse, improper or insufficient care or maintenance. **DAMAGE CAUSED BY THE USE OF OTHER REPLACEMENT PARTS NOT MEETING THE DESIGN SPECIFICATIONS OF THE ORIGINAL PARTS WILL NOT BE COVERED BY THIS LIMITED WARRANTY.** The cost of normal maintenance or replacement parts which are not in breach of the limited warranty are the responsibility of the purchaser. Prior to using products, the purchaser shall determine the suitability of the products for the intended use and assumes all related risk and liability. Any assistance JOME provides to or procures for the purchaser outside the terms, limitations or exclusions of this limited warranty will not constitute a waiver of the terms, limitations or exclusions, nor will such assistance extend or revive the warranty. JOME will not reimburse the purchaser for any expenses incurred by the purchaser in repairing, correcting or replacing any defective products or parts, except those incurred with JOME's prior written permission. **JOME'S AGGREGATE LIABILITY WITH RESPECT TO COVERED PRODUCTS IS LIMITED TO AN AMOUNT EQUAL TO THE PURCHASER'S ORIGINAL PURCHASE PRICE PAID FOR SUCH PRODUCT.**

How To Obtain Warranty Service

To obtain warranty service in the U.S., the product believed to be defective, and proof of original purchase (including the date of purchase), must be presented to Minn Kota's factory service center in Mankato, MN. Any charges incurred for service calls, transportation or shipping/freight to/from the factory, labor to haul out, remove, re-install or re-rig products removed for warranty service, or any other similar items are the sole and exclusive responsibility of the purchaser. Products purchased outside of the U.S. must be returned prepaid with proof of purchase (including the date of purchase and serial number) to any Authorized Minn Kota Service Center in the country of purchase. Warranty service can be arranged by contacting the factory at 1-800-227-6433 or email service@minnkotamotors.com. **Products repaired or replaced will be warranted for the remainder of the original warranty period [or for 90 days from the date of repair or replacement, whichever is longer]. For any product that is returned for warranty service that JOME finds to be not covered by or not in breach of this limited warranty, there will be a billing for services rendered at the prevailing posted labor rate and for a minimum of at least one hour.**

NOTICE: Do not return your Minn Kota product to your retailer. Your retailer is not authorized to repair or replace products.

NOTICE: THERE ARE NO EXPRESS WARRANTIES OTHER THAN THESE LIMITED WARRANTIES. IN NO EVENT SHALL ANY IMPLIED WARRANTIES INCLUDING ANY IMPLIED WARRANTIES OF MERCHANTABILITY OR FITNESS FOR PARTICULAR PURPOSE, EXTEND BEYOND THE DURATION OF THE RELEVANT EXPRESS LIMITED WARRANTY. IN NO EVENT SHALL JOME BE LIABLE FOR PUNITIVE, INDIRECT, INCIDENTAL, CONSEQUENTIAL OR SPECIAL DAMAGES. Without limiting the foregoing, JOME assumes no responsibility for loss of use of product, loss of time, inconvenience or other damage.

Some states do not allow limitations on how long an implied warranty lasts or the exclusion or limitation of incidental or consequential damages, so the above limitations and/or exclusions may not apply to you. This warranty gives you specific legal rights and you may also have other legal rights which vary from state to state.

FEATURES

i-PILOT REMOTE

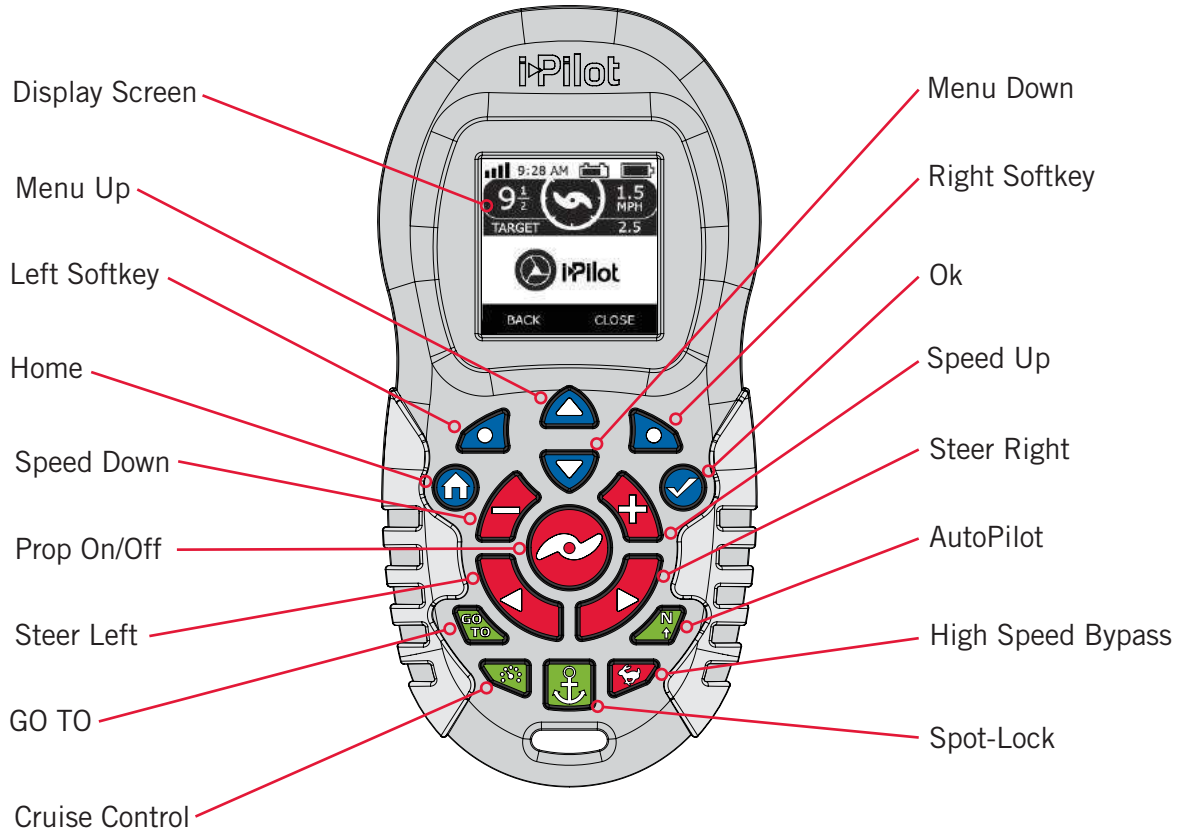

i-PILOT CONTROL HEAD

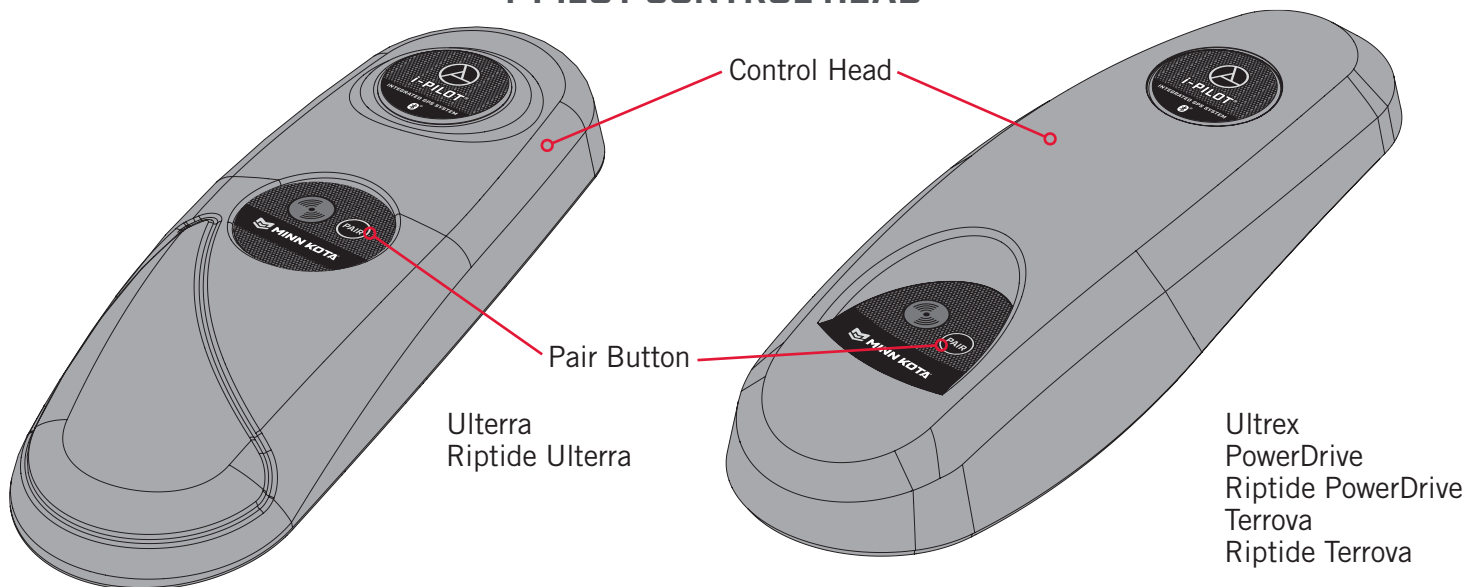

NOTICE: Specifications subject to change without notice. This diagram is for reference only and may differ from your actual product.

REMOTE BUTTONS

MENU CONTROL BUTTONS >



Home

Pressing this button will always bring you to the Home Screen.



Ok

Press to accept menu selections. Press to power remote on. Press and hold for 3 seconds to power remote off.



Left Softkey & Right Softkey

Buttons change function based on the mode of operation and which screen is presently displayed. Softkey labels at the bottom of the display screen indicate current function.



Menu Up & Menu Down

Used to navigate softkey labels and menus.

NOTICE: The remote is waterproof, but will not float.

MANUAL CONTROL BUTTONS >



Speed Down & Speed Up

Press to increase or decrease motor speed.



Prop On/Off

Pressing this button will turn the Prop on and off.





Steer Left & Steer Right





Press to steer the motor to the left or to the right.



High Speed Bypass

Bypasses the current motor speed to speed 10. Quickly double press to engage. Single press to disengage.

NOTICE: If Steer Right  or Steer Left  is held down for more the six to eight seconds, the steering will stop to prevent the coil cord from wrapping around the shaft on some models.

NOTICE: If your motor is connected to a Heading Sensor, the Speed Down  (backwards), Speed Up  (forward), Steer Right  and Steer Left  buttons function change to Jog the boat while in Spot-Lock.

NAVIGATION BUTTONS >



GO TO

Opens the list of Spot-Locks and iTracks that are within navigable range.



Cruise Control

Press to enable Cruise Control.



Spot-Lock

Press to enable Spot-Lock.



AutoPilot

Press to enable AutoPilot.

HEADER & ICONOGRAPHY

HEADER >

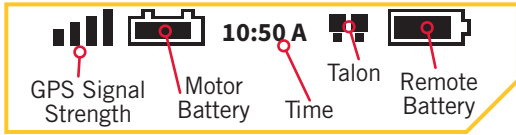

GPS Signal Strength
Shows the level of GPS signal strength. If no bars appear, the system has not yet acquired a GPS fix.

Motor Battery ◆
Displays motor battery level when prop is disengaged.

10:50 A Time
Displays the current time.

Remote Battery
Displays the battery level of the remote.

Talon
Displays the connection with one or two Talons and indicates if the Talon(s) are deployed.

ICONOGRAPHY >

Spot-Lock
Displays when Spot-Lock is engaged.

Spot-Lock Jog
Displays when Spot-Lock is engaged and the motor is communicating with a Heading Sensor.

Legacy AutoPilot
Displays when AutoPilot is engaged and the AutoPilot Mode is set to Legacy.

Advanced AutoPilot
Displays when AutoPilot is engaged and the AutoPilot Mode is set to Advanced.

Record
Displays when an iTrack is being recorded.

iTrack
Displays when an iTrack is being navigated.

Prop Lockout
Displays when the Prop is locked-out during certain functions.

Trim ◆
Displays when Trim is being adjusted.

Brightness
Displays when screen brightness is being adjusted.

Talon Selection
Displays the active Talon as either left, right or both.

Prop
Displays when the Prop is enabled. Rotates when the Prop is on and the Prop Speed is greater than zero. Blinks when a mode of navigation is used that requires the prop to be enabled.

10 Prop Speed
Displays the current Prop Speed. Can be adjusted in 1/2 speed increments between 0 and 10.

0.7 mph Ground Speed
Displays the current speed over ground.

TARGET 1.5 Cruise Control
Displays the Target Speed when Cruise Control is engaged.

Lock
Displays when the Remote is locked.

Scroll Up & Down
Displays when the softkey labels at the bottom of the display screen have more options available.

◆ Only available with Ultrerra.

■ Only available with Ultrex.

DISPLAY SCREEN

SAMPLE SCREENS >

Become familiar with some of the display screens used on the i-Pilot remote interface.

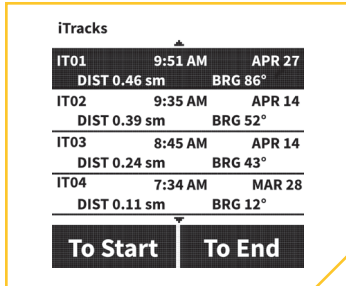

A list of iTracks that are in navigable range. The date and time listed are generated when the track is recorded.

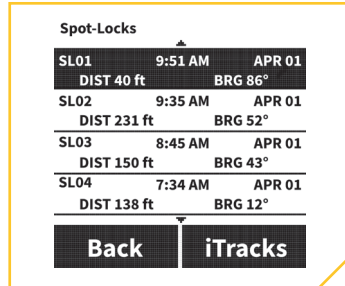

A list of Spot-Locks that are in navigable range. The date and time listed are generated when the Spot-Lock is saved.

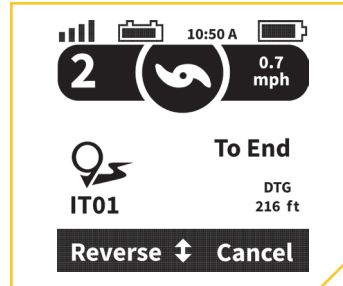

Navigating an iTrack when the boat is on course to go to the end of the iTrack.

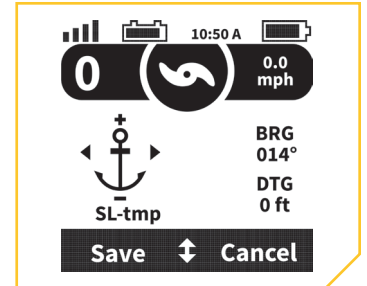

A temporary Spot-Lock created when the Spot-Lock button is pressed and Spot-Lock Jog is available.

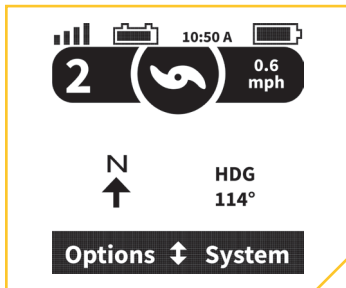

Navigating with Legacy AutoPilot.

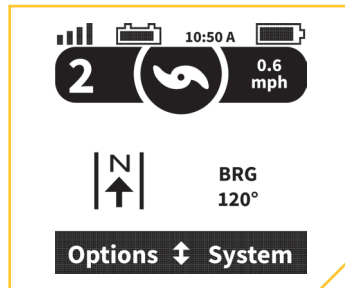

Navigating with Advanced AutoPilot.

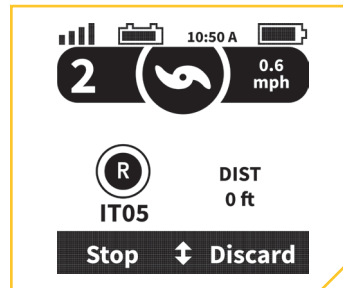

Recording an iTrack.

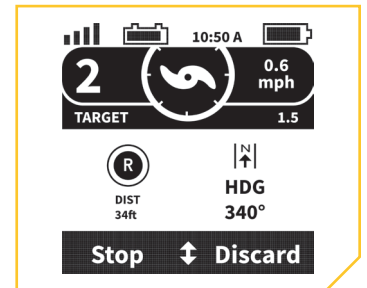

Recording as iTrack while in Advanced AutoPilot.

TERMS & ABBREVIATIONS >

Become familiar with common terms and abbreviations in order to understand what the remote is communicating about runtime navigational data.

To Start To Start

When recording or navigating an iTrack, the To Start location is the beginning of the iTrack.

To End To End

When recording or navigating an iTrack, the To End location is the end of the iTrack.

DTG Distance To Go

When Navigating to a Spot-Lock it is the distance left before the destination is reached. When navigating an iTrack it is the distance to go to reach either the To Start or To End location on the iTrack depending on which direction the iTrack is being navigated.

DIST Distance

Distance from the boat's current location to a Spot-Lock or the boat's location and closest point on an iTrack.

BRG Bearing

Bearing is the direction from the boat's current location to the target destination. A target destination can be a Spot-Lock or iTrack.

HDG Heading

Heading is the direction that the motor is pointing or traveling.

GETTING STARTED

THE i-PILOT SYSTEM

The i-Pilot navigation system comes pre-installed on your trolling motor. If your motor comes with a Heading Sensor, the Heading Sensor needs to be installed and paired with the i-Pilot controller. The i-Pilot controller is contained in the motor Control Head. Please see the "Heading Sensor" portion of this manual for more information on the Heading Sensor. The i-Pilot remote also comes paired to the controller from the factory. The i-Pilot remote and controller make up the i-Pilot navigation system. The top of the motor Control Head also has a single pair button to allow additional remotes and the Heading Sensor to be paired to the system. A remote can only be paired with one controller at a time. The i-Pilot controller contains a very sensitive compass and is where all GPS satellite and i-Pilot remote signals are received. Before each startup, it is recommended to inspect the Remote, Propeller, and Control Head for damage and to make sure that there are no obstructions that would affect communication between the Control Head, the GPS signal and the Remote, or boat movement.

NOTICE: It is very important that the controller have a clear view of the sky in all directions and has a clear line of sight to the remote for optimum performance.

› Power

The i-Pilot controller will turn on whenever the trolling motor has power. Refer to the Owner's Manual for your specific motor to determine how to power up your trolling motor. Owner's Manuals can be found on-line at minnkotamotors.com. It is recommended to turn off and disconnect the power source from the trolling motor when not in use.

› Accuracy

The accuracy and responsiveness with which i-Pilot controls your boat is highly dependent upon many variables. Just a few of these variables and their general effects on responsiveness and accuracy are given below so that the behavior of the system can be understood.

⚠ CAUTION

This unit uses a magnetic compass to detect direction of travel. The compass can be adversely affected by magnets or large, ferrous metal objects near (within 24" of) the trolling motor control head.

Obstructions on the propeller may cause excessive vibration of the motor head. This vibration can cause the compass to wander and erratic steering to occur. Clear the obstruction to return the motor to normal operation.

Power should be disconnected from the motor when not in use. Removing the motor from the power source will ensure that current is not reaching the electronics when not in use.

Variable	Effect
Ratio of motor thrust to boat weight	Excessive thrust on a smaller boat can cause i-Pilot to over correct. Not enough thrust on a large boat can cause i-Pilot to respond slowly.
Wind	Excessive wind and/or current can reduce i-Pilot's positioning accuracy.
GPS signal strength	The greater number of GPS signal bars the greater the accuracy.
Trolling motor battery power level	A fully charged battery will give the best performance.

› Navigation

i-Pilot uses GPS satellite signals as well as compass data to know where it is, where its heading and the direction the motor is pointing. Since i-Pilot depends on GPS satellite signals for navigation, a minimum GPS signal of one bar is required in order for GPS navigation controls to be enabled. Best results are achieved when GPS signals of four bars can be obtained.

i-Pilot also uses a method of GPS navigation called Arrival Circles. These imaginary circles allow i-Pilot to understand when it has drifted away from a point and when it has arrived at a point. The size of the circle varies depending on signal strength. The greater the signal strength the smaller the Arrival Circle.

› Range

The range of the remote will be greatly reduced if it is used near or mounted to any metal object including aluminum or steel. It is also recommended that the front end of the remote not be obstructed during use.

› Battery

The Remote is powered by three Alkaline AAA batteries. It is recommended to always use this type of battery to get the best performance and battery life. By default, the remote will automatically turn itself off thirty minutes after the last button press.

NOTICE: Remote battery life is subject to frequency of use and is especially impacted by how often and bright the LCD backlight is used.

⚠ CAUTION

Fluctuating temperatures can lead to battery damage, such as capacity loss, leakage or rupture of batteries. Damaged batteries may damage your remote. Minn Kota recommends removing batteries from the remote when it is not expected to be used for extended periods of time, or for long-term storage, to avoid remote damage from the batteries.

SYSTEM STARTUP ›

Follow these simple steps each time you power up your trolling motor for successful operation:

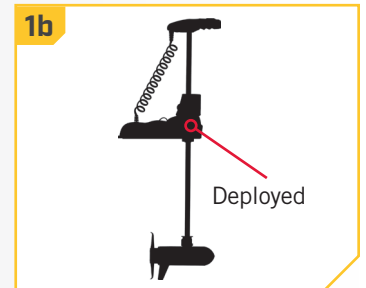
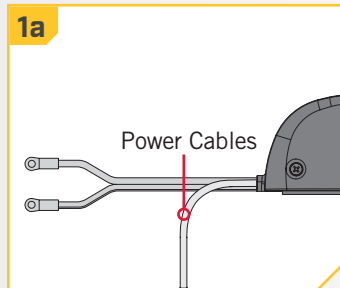

- 1
 - a. Connect trolling motor to power.
 - b. Deploy trolling motor into water.

NOTICE: i-Pilot startup varies slightly between trolling motor models. The Ulterra i-Pilot controller, in the Control Head, can communicate with the remote when the motor is stowed, once the motor and remote have power.









GETTING STARTED

2

- c. Push the Ok  button on your remote. The display screen will turn on. A message about i-Pilot operation will appear on the display screen. Use the Right Softkey  to select OK.
- d. The display screen will then show the Home Screen.

NOTICE: The Home Screen will vary slightly in appearance based on motor model and factory default selections.

- e. You are now able to use all manual functions in the remote including Speed Up , Speed Down , Steer Left , Steer Right , Prop On/Off , and High Speed Bypass .
- f. After i-Pilot has obtained a minimum GPS signal strength of one bar, all remaining functions will become available.

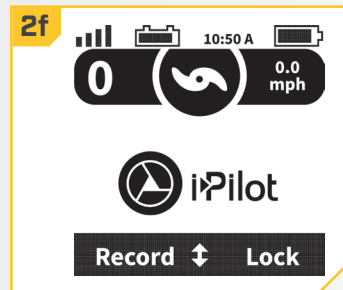
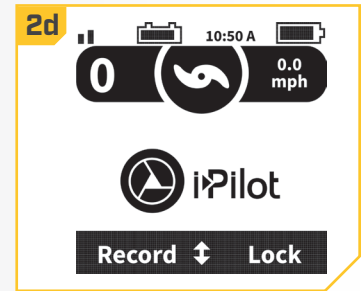
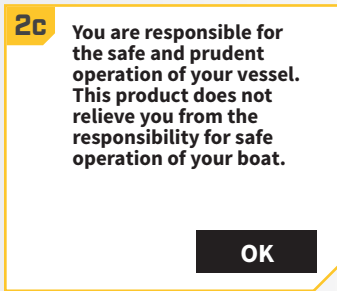

AUDIO MODES



AUDIO MODES

The i-Pilot controller in the Control Head contains an internal speaker which can be configured to work in two different audio modes. The unit is factory set to Audio Mode 2. Review the modes below to determine what audio patterns are caused by conditions in each audio mode.

Audio Pattern	What Condition Causes Audio Pattern	Audio Mode
Error	Attempting to enable a GPS feature when no signal strength bars are shown.	Mode 2
	Attempting to replay an iTrack or recall a Spot-Lock location when the boat is beyond the minimum required distance.	Mode 2
	The Momentary Button on the foot pedal is pressed, for applicable motors, and a remote button press attempts to override it.	Mode 2
	When GPS signal strength goes to no bars while in a GPS-based mode.	Mode 2
	When overriding navigation by steering with the foot pedal or remote.	Modes 1 and 2
Single Beep	Speed + (When less than maximum speed.)	Mode 2
	Speed - (When greater than speed 0.)	Mode 2
	Enable High Speed Bypass.	Mode 2
	Switch to Audio Mode 1	Modes 1 and 2
	Manual Prop on	Mode 2
	Enabling or disabling Record, GO TO, AutoPilot, Cruise Control or Spot-Lock.	Mode 2
Double Beep	Disable High Speed Bypass.	Mode 2
	Switch to Audio Mode 2	Modes 1 and 2
	Manual Prop off	Mode 2
3 longer Beeps	Pair successfully completed	Modes 1 and 2
4 Short Beeps	Startup	Modes 1 and 2
Steady Tone	Pair button is pressed.	Modes 1 and 2
High-Low, High-Low, High-Low	End of iTrack attained during track playback (in conjunction with canceling mode and turning the prop off)	Mode 2

AUDIO MODE CONTROL >





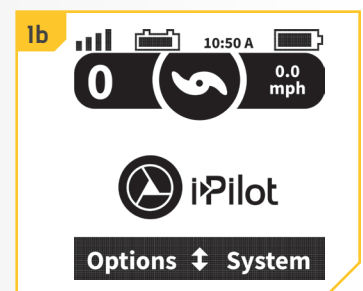
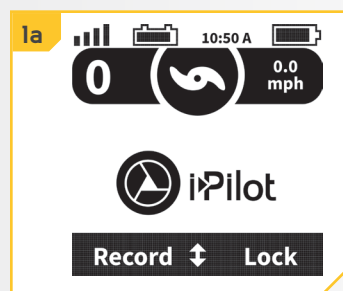

> Changing the Audio Mode

- 1
 - a. Press the Home  button.
 - b. Use the Menu Up  and Menu Down  buttons to find the Options menu at the bottom of the display screen.



AUDIO MODES

2

- c. Use the Left Softkey  to select the Options menu.
- d. Use the Menu Up  and Menu Down  buttons to find the Audio Mode menu. Use the Ok  button to select it.
- e. Use the Menu Up  and Menu Down  buttons to scroll to the desired Audio Mode. Use the Ok  button to select it.

NOTICE: When Audio Mode 1 is selected, the Control Head will emit one beep. When Audio Mode 2 is selected, the Control Head will emit two beeps.

- f. Use the Right Softkey  to close the menu.

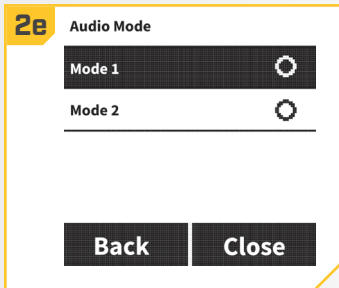
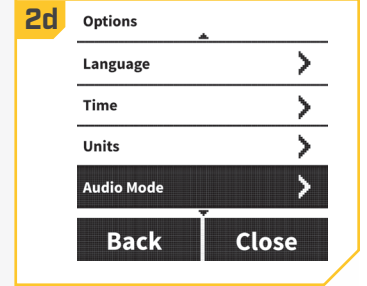
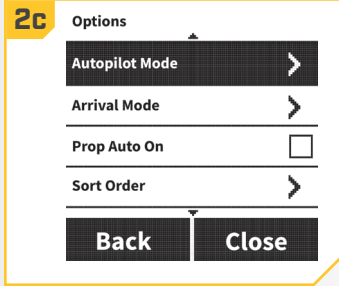

SPOT-LOCK

HOW SPOT-LOCK WORKS



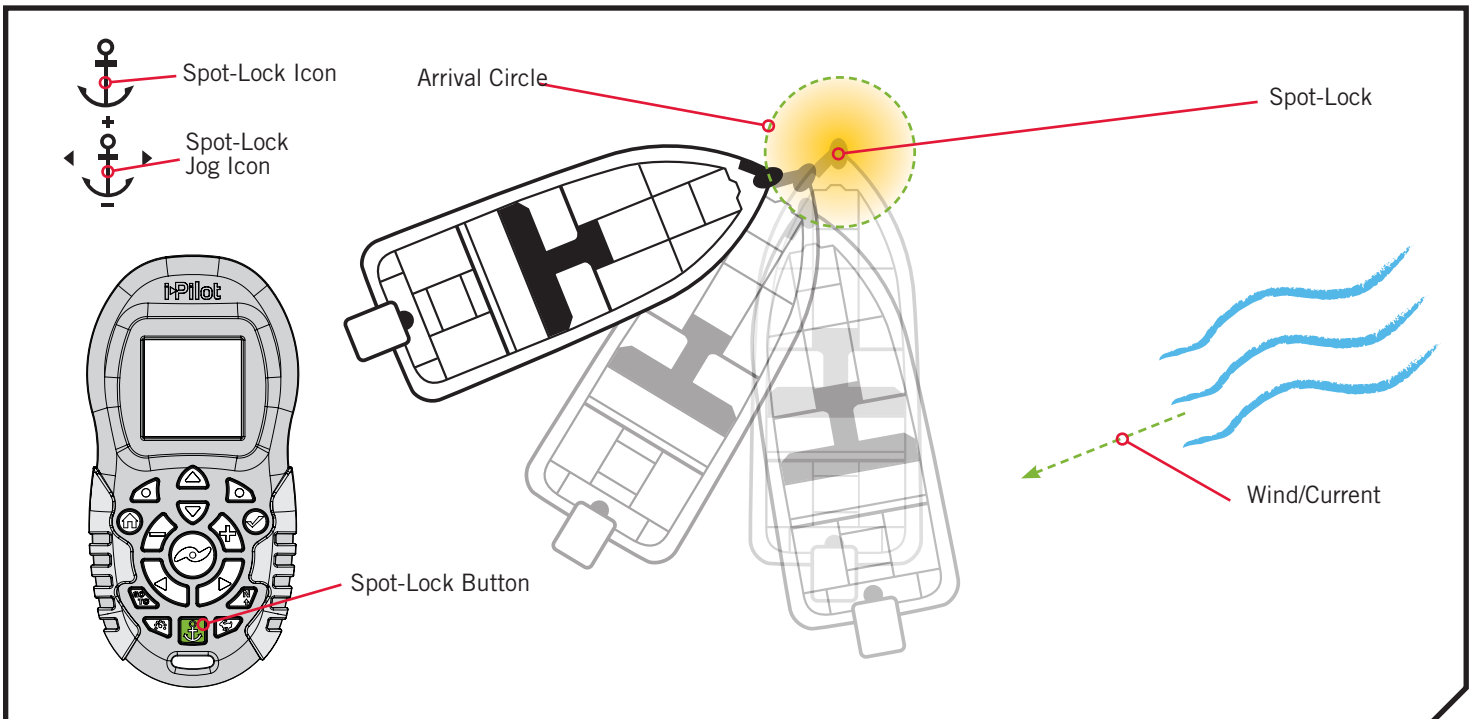

Spot-Lock uses a single point of reference that is recorded when the Spot-Lock button is pressed. The reference point is a set of GPS coordinates based on the location of the motor at the moment the button is pressed. This point is recorded and can be saved into one of the Spot-Lock memory locations. Spot-Lock works by creating an Arrival Circle around the Spot-Lock that the motor will automatically navigate to and try to stay within. Spot-Lock engages the motor to keep it in the Arrival Circle around the Spot-Lock location. If i-Pilot sees the motor is within the Arrival Circle, it will adjust the motor speed to zero. If i-Pilot sees the motor is outside of the circle, it will control motor speed and direction in an attempt to get the boat back into the Arrival Circle.

NOTICE: Spot-Lock is based on the location of the motor, not on the location or direction of the boat. Outside forces such as wind and current will cause the boat to move around the Arrival Circle. Spot-Lock will navigate to maintain the motor within the Arrival Circle regardless of the position of the boat.







SPOT-LOCK FUNCTIONS >

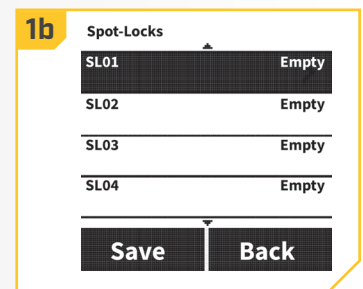
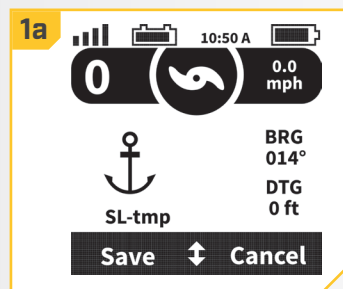

> Engaging Spot-Lock

- 1
 - a. Press the Spot-Lock  button on the remote.
 - b. The information for the temporary Spot-Lock location will show up on the display screen. Use the Menu Up  and Menu Down  buttons to find the Save softkey label at the bottom of the display screen. To save the Spot-Lock, press the Left Softkey  to open the Save menu.



2

- c. The Save menu brings up a list of Spot-Locks. Use the Menu Up  and Menu Down  buttons to select one of the Spot-Lock memory locations.
- d. Press the Left Softkey  to Save the Spot-Lock into the selected menu location. Press the Right Softkey  to go Back to the previous screen.

NOTICE: If the Spot-Lock button is accidentally pressed, press the Spot-Lock  button again or press the Right Softkey  to select Cancel from the menu to escape Spot-Lock.



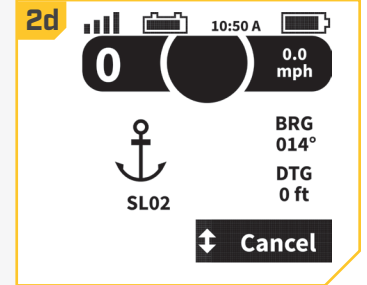
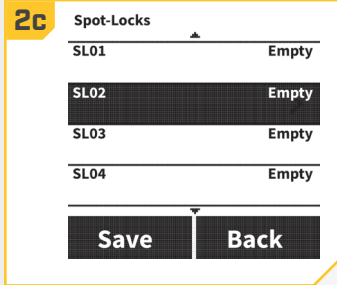

NOTICE: 16 Spot-Lock memory locations may be recorded.



NOTICE: If a Spot-Lock is already saved to a Spot-Lock memory location, it will automatically overwrite previously saved data for that memory location when you select Save. Once a new Spot-Lock is saved into memory, the previous Spot-Lock cannot be recalled.

Disengaging Spot-Lock

1

- a. When Spot-Lock is engaged, press the Spot-Lock  button to disengage Spot-Lock, or use the Menu Up  and Menu Down  buttons to find the Cancel softkey label at the bottom of the display screen.
- b. Use the Right Softkey  to select Cancel.

NOTICE: If your motor is equipped with a foot pedal, pressing any motor control button on the foot pedal will disengage Spot-Lock.

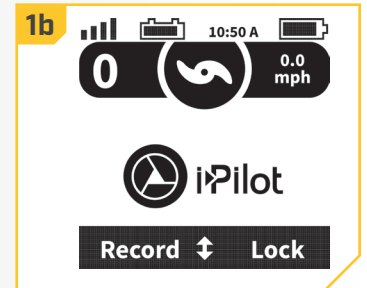
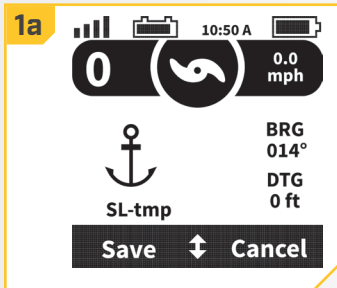

Re-engage a Saved Spot-Lock

1



- a. Manually navigate the boat to within a quarter mile of the saved Spot-Lock location.
- b. Press the GOTO  button on the remote.

WARNING

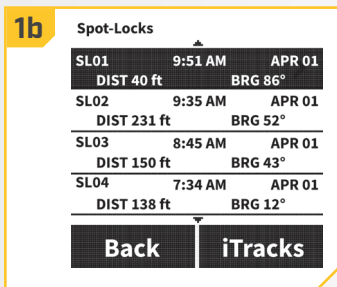
Due to safety reasons, i-Pilot will not re-engage a saved Spot-Lock location greater than a quarter mile away.



2



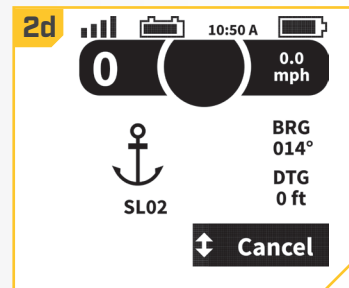
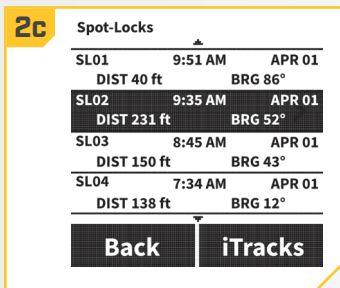





- c. The Spot-Locks menu will appear on the display screen. Use the Menu Up  and Menu Down  buttons to scroll to a saved Spot-Lock location in the menu.
- d. Press the Ok  button to select a saved Spot-Lock location.



Spot-Lock Jog

Spot-Lock Jog is a feature that is only available when the i-Pilot controller is paired with a Heading Sensor. For information on the Heading Sensor, go to the "Heading Sensor" section of this manual.

1

- a. To engage Spot-Lock Jog, first engage Spot-Lock. The Spot-Lock Jog icon will look like the Spot Lock icon, but will also have directional indicators.
- b. Use the Speed Down , Speed Up , Steer Left , Steer Right , buttons to move the boat 5 feet in the desired direction from the original Spot-Lock.
- c. The boat will be moved backwards for Speed Down , forward for Speed Up , left for Steer Left , and right for Steer Right , when the corresponding button is pressed in relation to the direction of the boat. Once the boat has jogged to the new location, the new location will be saved into a temporary Spot-Lock Memory and the boat will relate additional jogging with the temporary Spot-Lock location.

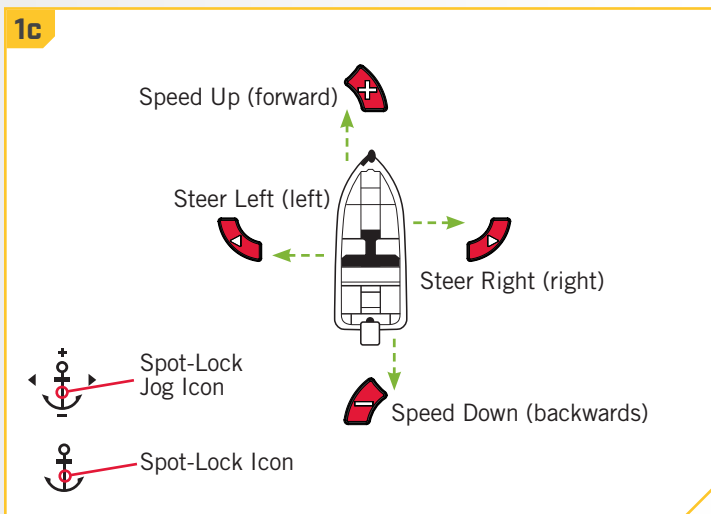
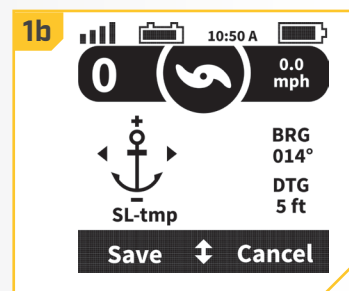
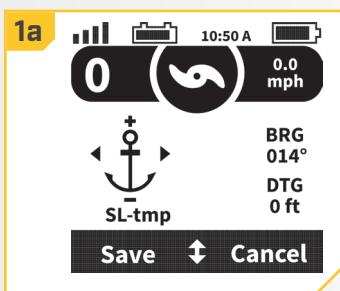

NOTICE: A Heading Sensor is required for Spot-Lock Jog. If your motor is not paired with a Heading Sensor, the Spot Lock icon will appear without the directional indicators and the option to jog will not be available.

NOTICE: Spot-Lock Jog moves the GPS coordinates of the Spot-Lock location based on the orientation of the boat as determined by communication with the Heading Sensor. The Spot-Lock location can be jogged multiple times consecutively. Once the Spot-Lock location has been jogged, the i-Pilot navigational system will recognize the new Spot-Lock location, and i-Pilot will control the motor to move the boat accordingly.

CRUISE CONTROL

i-PILOT WITH CRUISE CONTROL

During regular operation of the i-Pilot navigational system, the user can control prop speed. The controller will communicate the speed over ground to the remote and the remote will display it. The speed over ground is the speed that the boat is traveling and will vary based on environmental factors such as wind and current, even if the prop speed remains the same. Cruise Control helps to compensate for the variations in external forces that effect the speed over ground and keeps the boat traveling at an even speed. When Cruise Control is engaged, the current speed over ground becomes the Target Speed. Cruise Control works to control the prop speed either up or down to match the speed over ground to the Target Speed.

WARNING

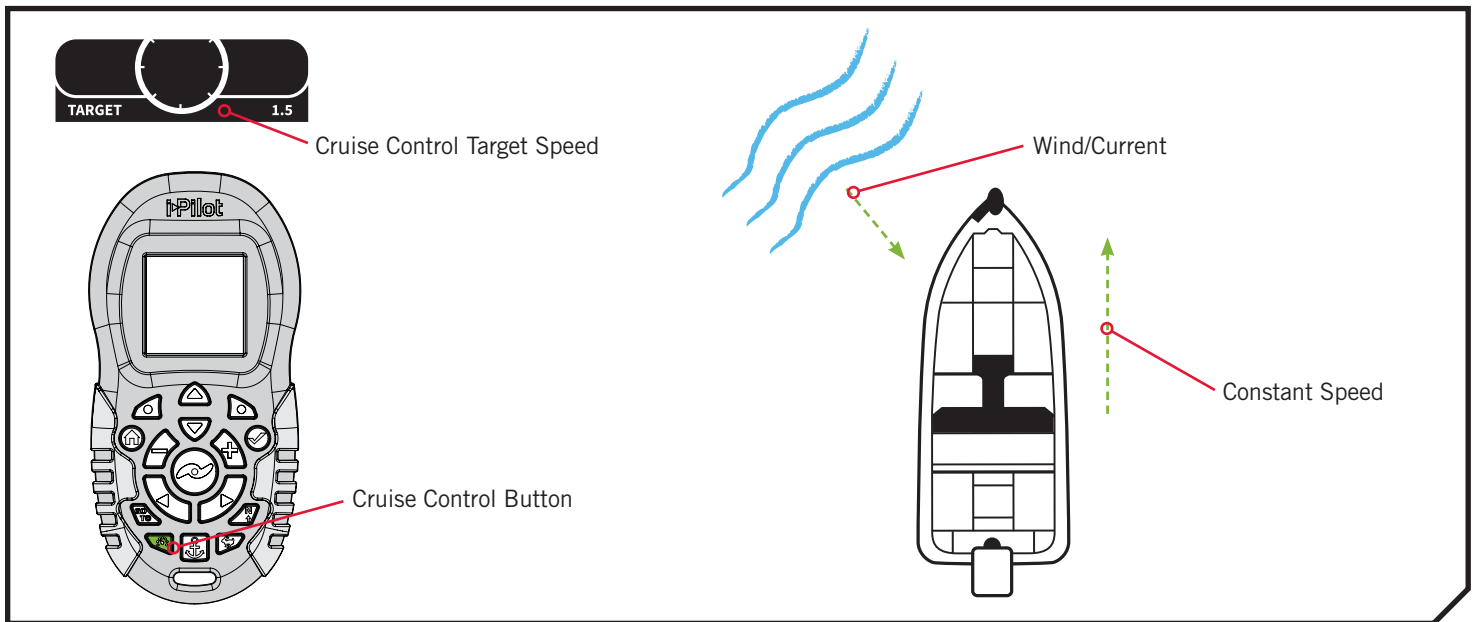

Watch for turning propeller when Cruise Control is engaged. The propeller will automatically turn on when Cruise Control is engaged, even if the engagements is accidental. A turning propeller can cause injury. Be mindful of the prop when engaging Cruise Control to prevent injury. The propeller will turn on regardless of the Auto Prop On setting. If the propeller is not "on" before the Cruise Control is engaged, it will be turned "on", or enabled and run at the current speed setting.



WORKING WITH CRUISE CONTROL >

> Engaging Cruise Control

1

- a. Press the Cruise Control  button on the remote.
- b. The Target Speed will appear on the display screen. Press the Speed Down  or Speed Up  buttons to adjust the Target Speed.

NOTICE: If the Prop is not turning, be sure to press the Prop Button  to enable it. The Prop Auto On setting does not affect Cruise Control.

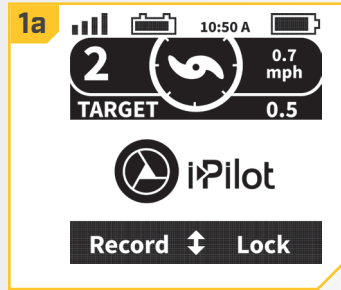

> Disengaging Cruise Control





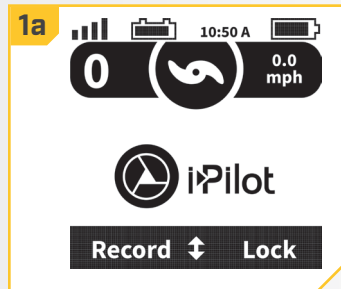

1



- a. When Cruise Control is engaged, press the Cruise Control  button on the remote to disengage Cruise Control.



› Jump To or Set a Cruise Control Preset

1

- a. To jump to or set a Cruise Control Preset, first engage Cruise Control.
- b. Use the Speed Down  or Speed Up  buttons to change the Target Speed. While adjusting the Target Speed, the menu at the bottom of the display screen temporarily changes to display two Preset Target Speeds.
- c. While the Presets are showing, press either the Left Softkey  or Right Softkey  to jump to the corresponding Preset on the display screen.
- d. To save the Preset to a new value, adjust the Target Speed to the desired value. While the Presets are showing in the menu at the bottom of the display screen, press and hold either the Left Softkey  or Right Softkey .

NOTICE: The Left Softkey  will jump to or save the Preset Target Speed displayed on the left side of the menu that appears. The Right Softkey  will jump to or save the Preset Target Speed displayed on the right. Once saved, a message will flash on the screen stating "Preset Saved" and then disappear.

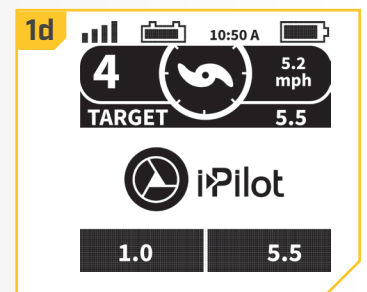
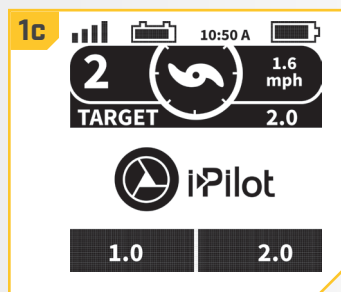
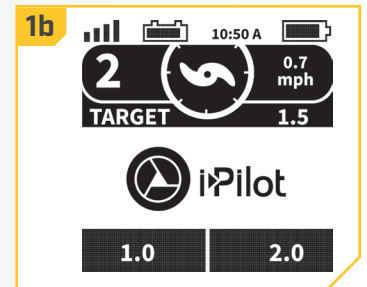
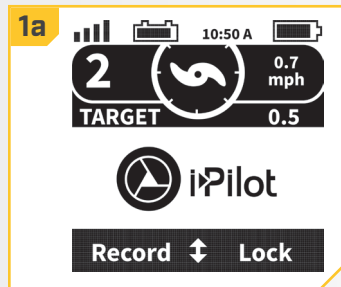

HIGH SPEED BYPASS

MOTOR SPEED AND HIGH SPEED BYPASS

The Motor Speed with High Speed Bypass is set to 10 when engaged and returns to the previously set speed when disengaged.

WARNING

Watch for a turning propeller when High Speed Bypass is engaged. A turning propeller can cause injury. High Speed Bypass will automatically turn the prop on to Speed 10, even if the engagement is accidental.

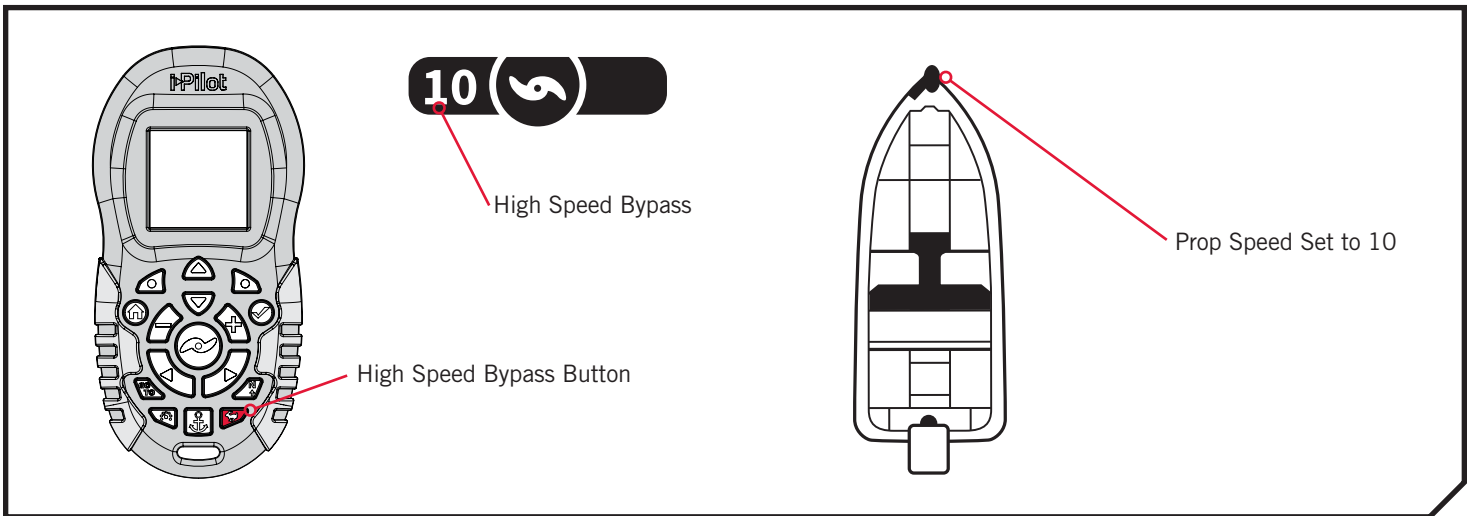

CONTROLLING HIGH SPEED BYPASS >

> Engaging High Speed Bypass

- 1 a. Quickly double press the High Speed Bypass  button on the remote.

NOTICE: When engaging High Speed Bypass, quickly double press the button twice to engage. The remote will not recognize the press as a double press if the time between presses is too delayed.

- b. The Prop Speed will automatically display 10.

NOTICE: If the Prop is not turning, be sure to press the Prop Button  to enable it. The Prop Auto On setting does not affect High Speed Bypass. If High Speed Bypass is engaged and the prop is flashing, it needs to be turned "on" in order for High Speed Bypass to work.

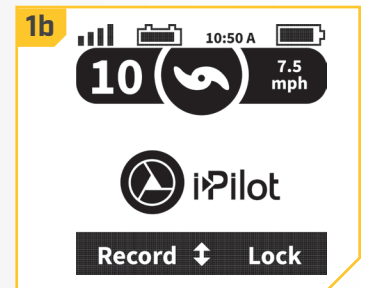
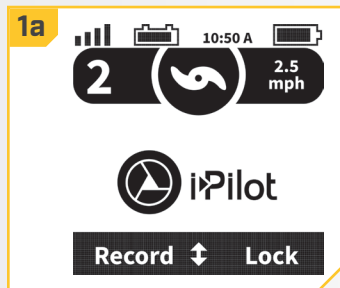

Disengaging High Speed Bypass

1

- a. When High Speed Bypass is engaged, press the High Speed Bypass  button on the remote to disengage High Speed Bypass.

NOTICE: Manually adjusting the speed below speed 10 will also disengage High Speed Bypass.

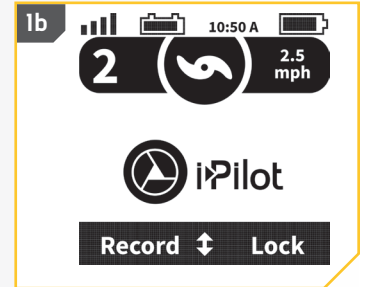
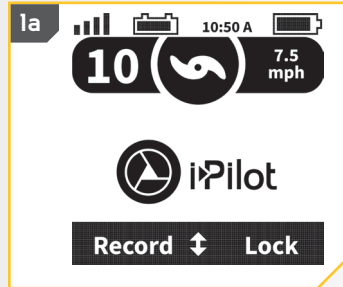

AUTOPILOT

i-PILOT WITH AUTOPILOT

When in AutoPilot, i-Pilot keeps the trolling motor pointed in the direction you want to go. Each time the wind or water current moves the boat off course, the AutoPilot senses the change and steers itself back to the original heading. The AutoPilot direction is set every time a steering change is made. To change direction, steer until the Control Head points to the desired course. AutoPilot will pull the bow of the boat around and correct automatically until the boat is moving in the direction you chose.

AUTOPILOT MODES

Two different modes of AutoPilot are available, Advanced AutoPilot and Legacy AutoPilot. Both are collectively referred to as AutoPilot. There are distinct differences between the two AutoPilot Modes and how they control your boat. Both Advanced AutoPilot and Legacy AutoPilot are valuable tools the fisherman can use for accurate and precise bait presentation. We highly recommend getting on the water and trying both Advanced AutoPilot and Legacy AutoPilot in various fishing situations and applications. With experimentation and time you will find which AutoPilot Mode works best for you in any given situation.

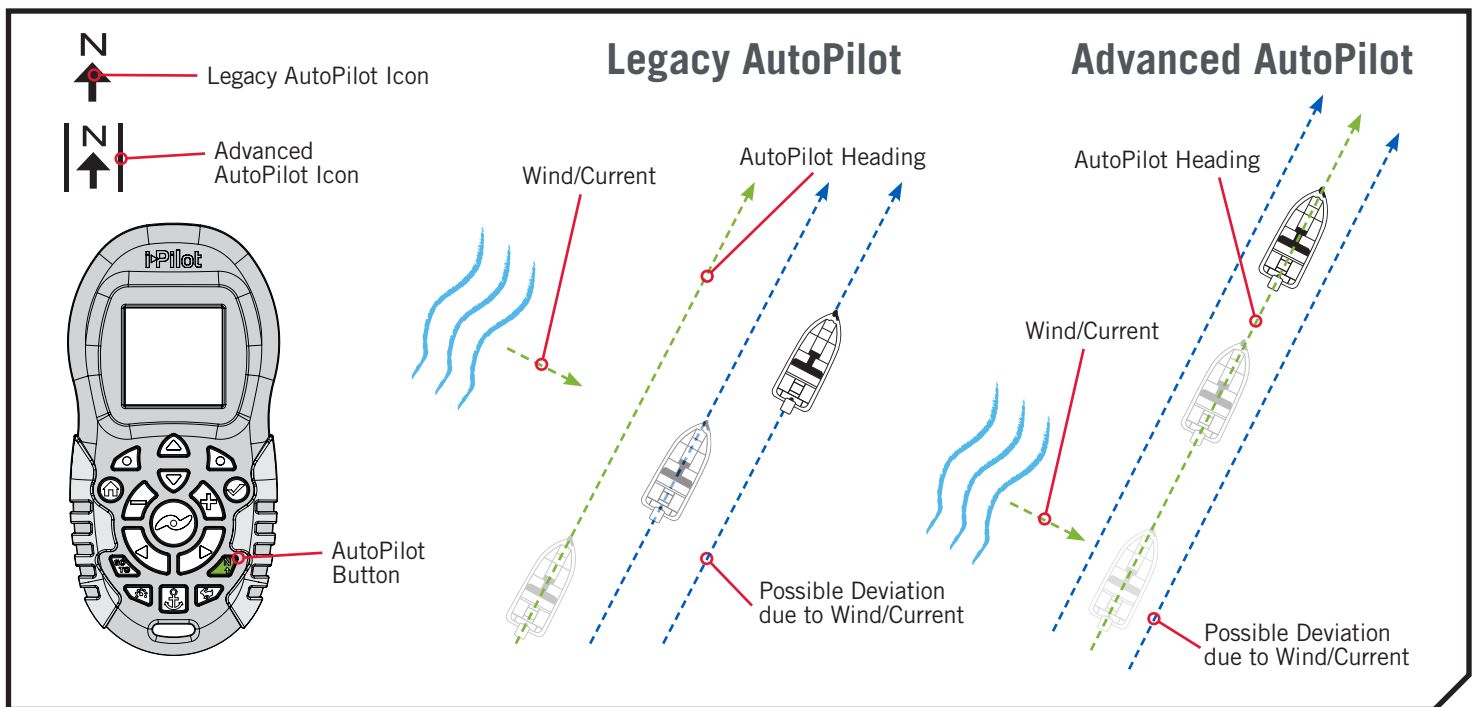

› Legacy AutoPilot

AutoPilot uses an internal compass to provide heading lock. When Legacy AutoPilot is on, it keeps the motor pointed in the same compass direction. If a manual steering correction is made, Legacy AutoPilot locks onto the new compass heading to which the boat was steered. This method of heading tracking does not take into account external forces such as a side wind or currents, which can allow side drift.

› Advanced AutoPilot

Advanced AutoPilot not only uses compass heading but also GPS data to correct for cross winds, current and other external forces to keep the boat on the intended course. When Advanced AutoPilot is turned on, it creates a course that it will follow. When the user steers to a new heading, a new course is created. Advanced AutoPilot will keep the boat on the course in most conditions. When very extreme conditions exist such as very strong winds or current, the trolling motor may not have enough power to control the boat smoothly. In these extreme cases it may be best to use Legacy AutoPilot and let the boat move with the wind or current if the motor is not powerful enough to overcome it.

WORKING WITH AUTOPILOT >

> Engaging Legacy AutoPilot or Advanced AutoPilot

- 1
 - a. Press the AutoPilot  button on the remote.
 - b. The Legacy AutoPilot or Advanced AutoPilot icon will display on the screen.
 - c. To adjust the desired heading, manually steer the motor to the new heading. i-Pilot will automatically lock onto the new heading.

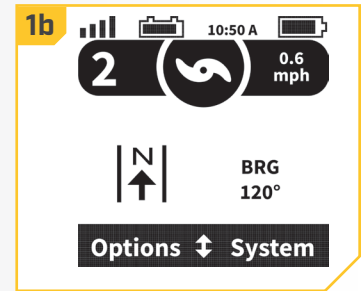
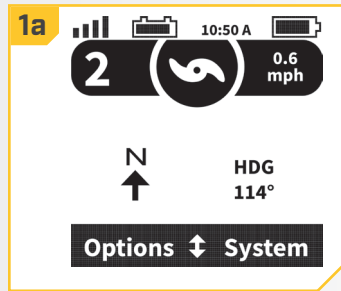

NOTICE: If the Prop is not turning, be sure to press the Prop Button  to enable it. If AutoPilot is engaged and the prop is flashing, it needs to be turned "on". The Prop behavior for AutoPilot can be changed with the Prop Auto On setting. Read "To Toggle the Prop Auto On" section of this manual for more information.

NOTICE: After steering to a new direction, there is a short delay before the direction is locked in to allow the compass to stabilize. When broad speed changes are made, the motor heading may change slightly. This is normal.

CAUTION

This unit uses a magnetic compass to detect direction of travel. The compass can be adversely affected by magnets or large, ferrous metal objects near (within 24" of) the trolling motor control head.

Obstructions on the propeller may cause excessive vibration of the motor head. This vibration can cause the compass to wander and erratic steering to occur. Clear the obstruction to return the motor to normal operation.

NOTICE: When AutoPilot is on and the trolling motor is pulled out of the water to the stow position, the steering motor will continue to run. Turn off AutoPilot to stop the motor. If AutoPilot is left on, the steering motor will shut off automatically after 8 seconds. The motor should not be stored in this condition for long periods as power is still being applied to all electronics. Always turn AutoPilot off and disconnect your motor from the battery when storing your motor.

> Disengaging Legacy AutoPilot or Advanced AutoPilot

- 1
 - a. Press the AutoPilot  button on the remote to disengage AutoPilot.

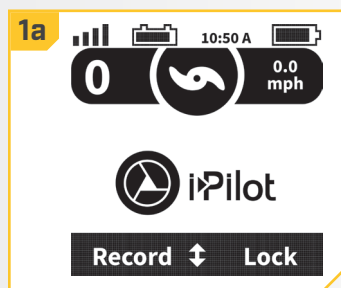







› To Set the Default AutoPilot Mode





AutoPilot has two modes:

1. Legacy - This method of heading tracking does not take into account external forces such as a side wind or currents, which can allow side drift.
2. Advanced - Advanced AutoPilot not only uses compass heading but also GPS signal data to correct for cross winds, current and other external forces to keep the boat on an intended course.

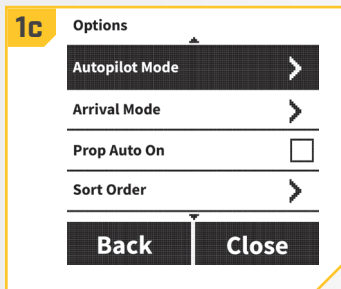
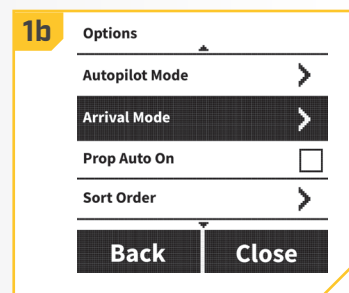
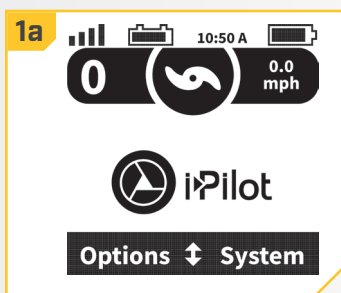
Once it is determined which AutoPilot Mode to operate in, use the following instructions to set it as the default.

- 1**
- a. Press the Menu Up  and Menu Down  buttons until the Options Menu appears at the bottom of the display screen.
 - b. Press the Left Softkey  to select the Options Menu.
 - c. Press the Menu Up  and Menu Down  buttons to navigate to the AutoPilot Mode menu option.
 - d. Press the Ok  button to select the AutoPilot Mode menu.



- 2**
- e. Press the Menu Up  and Menu Down  buttons to navigate to the AutoPilot Mode desired. Use the Ok  button to select it. The circle to the right of the selected AutoPilot Mode will become solid when selected and the corresponding icon will display on the bottom of the display screen when using AutoPilot.
 - f. Use the Right Softkey  to Close the AutoPilot Mode menu and return to the home screen.

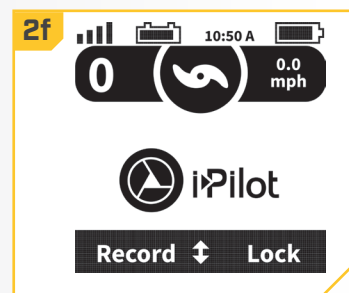
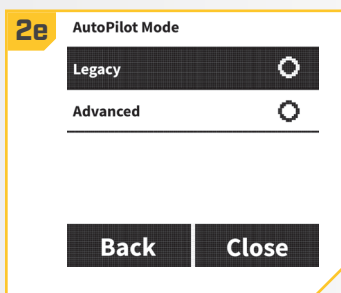

NOTICE: You can change the AutoPilot Mode while AutoPilot is engaged.