

MOUNTING THE FOOT PEDAL

› Mounting the Foot Pedal

Minn Kota recommends securing the Foot Pedal to the boat deck to prevent it from being damaged during transport and to make motor operation more efficient. It is recommended to use the Mounting Holes on the Foot Pedal for a secure mount. The Foot Pedal has three Mounting Holes. One Mounting Hole is located under the Heel End of the Foot Pedal. The other two are located under the Toe End of the Foot Pedal. Minn Kota recommends using a 1/8" or 3/16" diameter screw and only tighten enough to slightly compress the Bumper Pads underneath the Foot Pedal.

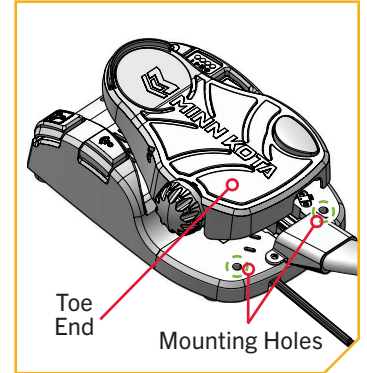
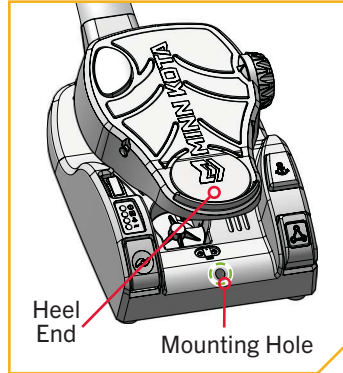

› Installing the Prop

The Ultrex QUEST trolling motor comes from the factory with two props, the Power Prop and the Weedless Wedge Prop. The Power Prop will provide maximum thrust and extra power. The Weedless Wedge Prop is 100% weedless to help move through high vegetation even at low speeds while conserving battery power. Determine which prop is best suited for the fishing environment and install it.

1

ITEM(S) NEEDED



⚠ CAUTION

Disconnect the motor from the battery before beginning any Prop work or maintenance.

- Take the Drive Pin (Item #44) and slide it through the Hole in the Armature Shaft. Position the Drive Pin horizontally by grasping the Armature Shaft and rotating it with the Drive Pin in place.
- Align the Prop (Item #38) so it is also horizontal and parallel with the Drive Pin. Slide the Prop onto the Armature Shaft and Drive Pin until it is seated against the lower unit.
- Install the Prop Washer (Item #40) and the Prop Nut (Item #42) onto the end of the Armature Shaft.

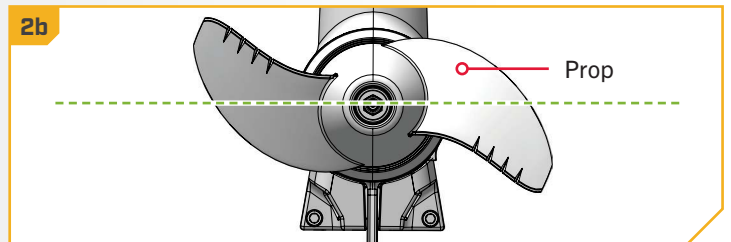
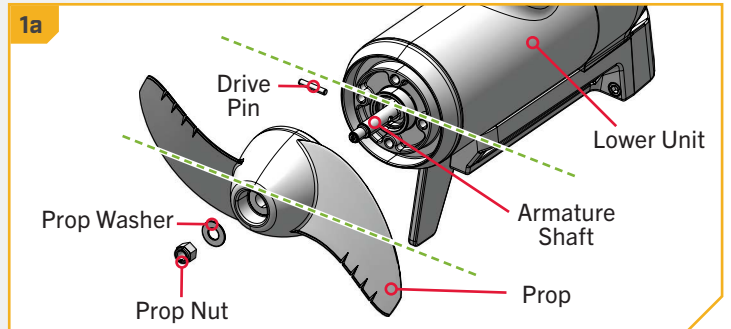

2

- d. While holding the Prop horizontal, tighten the Prop Nut with a 9/16" Deep Well Socket.
- e. Tighten the Prop Nut to 25-35 in-lbs.

CAUTION
Do not over-tighten as this can damage the prop.

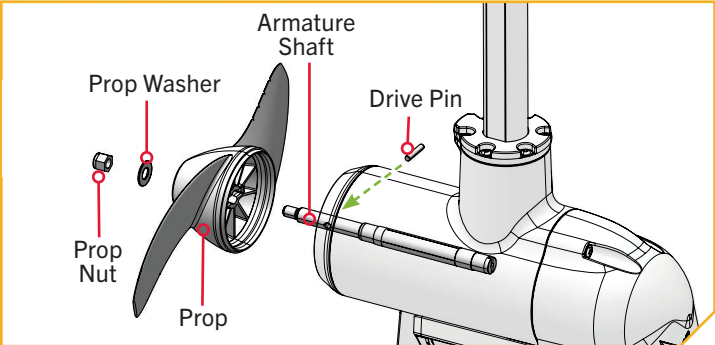

ONE-BOAT NETWORK

OPTIMIZING THE PERFORMANCE OF THE ULTREX QUEST WITH THE ONE-BOAT NETWORK APP

Minn Kota® and Humminbird® have joined forces to bring you the One-Boat Network (OBN). To get the most from your One-Boat Network, we encourage you to download the One-Boat Network app onto your smart device. The One-Boat Network® app is a free iOS and Android application that you can download to a mobile device, providing unparalleled control over all of your One-Boat Network connected products.

Completing the installation of the Ultrex QUEST through the One-Boat Network app should be done following the Prop installation. Recheck the OBN settings once the boat is trailered and the motor is used on the water. Minn Kota recommends connecting the trolling motor to the One-Boat Network app to assist in these steps. Find more information in the One-Boat Network app document included with the trolling motor or the One-Boat Network Owner's Manual found online at minnkota.johnsonoutdoors.com. Before beginning, be sure that the trolling motor is connected to a power source.



One-Boat Network app Icon



WARNING

Take care that neither you nor other persons approach the turning propeller too closely, neither with body parts nor with objects. The motor is powerful and may endanger or injure you or others. Stay clear of the Prop and watch out for accidental engagement.

ONE-BOAT NETWORK ADJUSTMENTS >

> Keel Offset

The Ultrex QUEST comes from the factory with the Lower Unit parallel to the Mount. When the Lower Unit is parallel to the Mount, the Keel Offset is zero. In an ideal installation, the Lower Unit will be parallel to the Keel, however, the Mount is rarely installed to be perfectly in-line with the Keel, therefore the Lower Unit will not be parallel with the Keel. Nearly all installations will have some variation in mounting position to either the Port or Starboard side of the boat. During installation, indexing the trolling motor corrects the position of the Foot Pedal to be parallel to the boat deck when the Lower Unit is parallel to the Keel. The Keel Offset feature records the position of the Lower Unit when it is parallel to the Keel and when the Foot Pedal is also parallel based on the Mount being offset from the Keel. Before adjusting the Keel Offset, complete all installation steps. This includes mounting the trolling motor to the deck of the boat, calibrating or rotating the Pedal Control Sleeve Assembly, and installing and securing the power and accessory cables. The Keel Offset is specified on the Ultrex QUEST through the One-Boat Network App with the Keel Mount Offset. Minn Kota recommends using the One-Boat Network app to complete the Keel Offset procedure. If the app is unavailable, Keel Offset can be set using a Humminbird Helix, Apex or Solix fish finder. If completing Keel Offset with the fish finder, please see the Owner's Manual for more information.

NOTICE: When the motor is installed from the factory, the motor Keel Offset is 0 degrees. When setting the Keel Offset, any position towards the Port will create a Keel offset of a negative angle. Any position towards Starboard will create a positive angle.

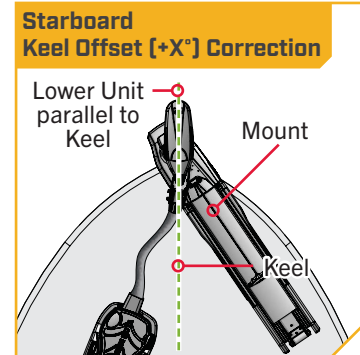
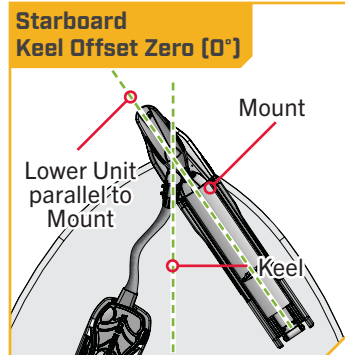
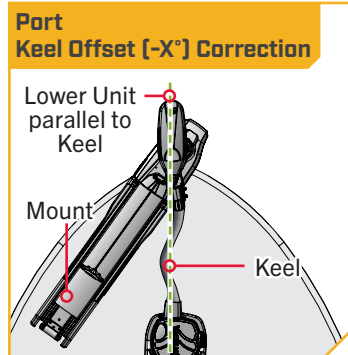
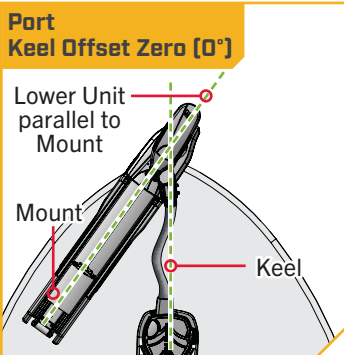

1

- Power on the trolling motor. When the blue LED next to the power icon is “on”, the system is ready.
- With either the One-Boat Network app on a paired mobile device, or the foot pedal, steer the motor so that the control head and lower unit are parallel to the Keel.

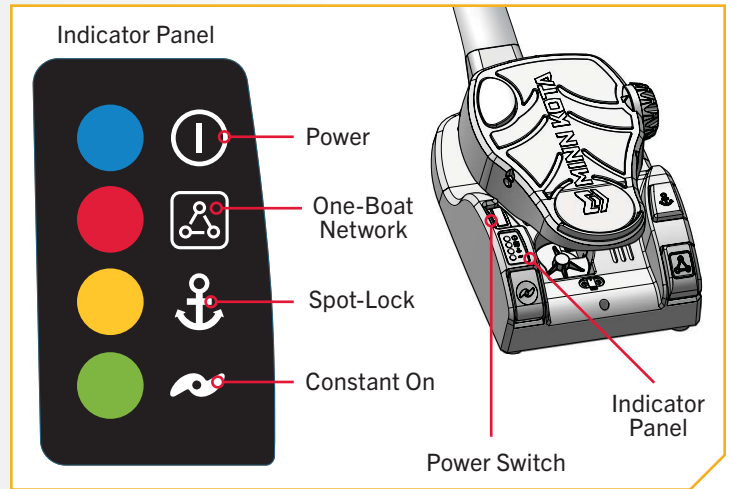
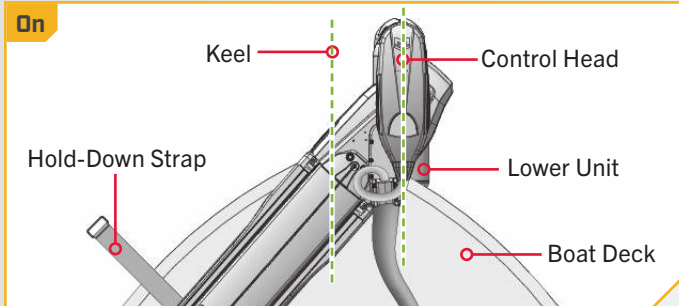

2

- Open the One-Boat Network (OBN) app on the mobile device. Make sure the mobile device is paired with the trolling motor.
- From the OBN home screen, tap the Motor menu. The Motor menu opens the Motor app home screen.
- Before the Motor app home screen will open, tap Agree on the on-screen prompt.

NOTICE: The on-screen prompt will only display once each time the app is launched. If the prompt has displayed, the Motor app home screen appears.

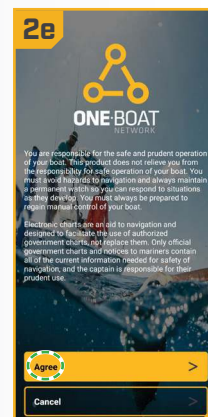
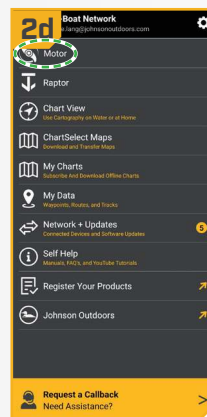

- On the Motor app home screen, locate the Motor Setting button in the upper right-hand corner and tap it.

3

- In the Motor Settings menu, find and tap Setup and Calibration.
- In Setup and Calibration, find and tap Keel Mount Offset.
- Review all safety warnings. Follow the prompts in the One-Boat Network app. If the placement of the trolling motor is pointing forward and parallel to the keel, tap Set. The degree of Keel Mount Offset shows at the bottom of the app Display.

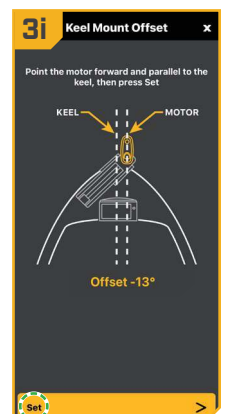
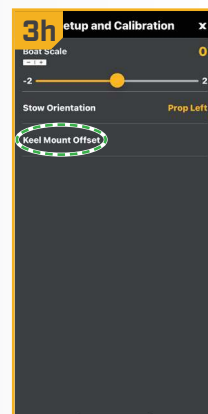
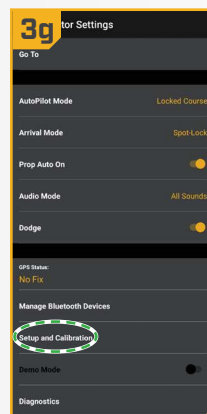

STRAIGHT ON DEPLOY

4

- j. If the trolling motor needs to be adjusted, locate the Return button on the top-left corner of the app screen. Tap the Return button three times until the Motor app home screen displays.
- k. Use the Steer Right > and Steer Left < buttons to point the motor forward and parallel to the keel.
- l. When satisfied with the placement of the trolling motor, locate the Motor Settings button in the top-right corner and tap it.
- m. In the Motor Settings menu, find and tap Setup and Calibration.
- n. In Setup and Calibration, find and tap Keel Mount Offset. If the placement of the trolling motor is pointing forward and parallel to the keel, tap Set.
- o. The degree of Keel Mount Offset shows at the bottom of the app Display. Tap Return to close the Keel Mount Offset and return to the home screen.

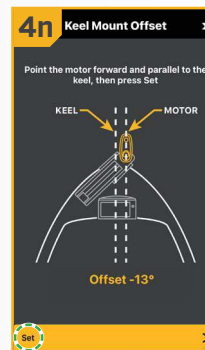
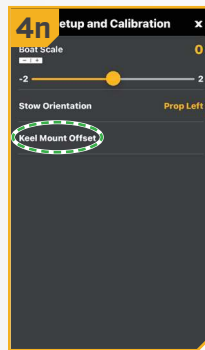
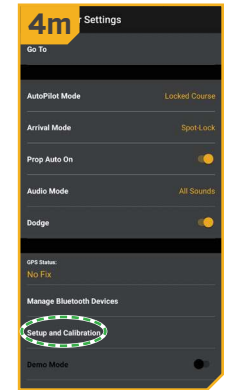
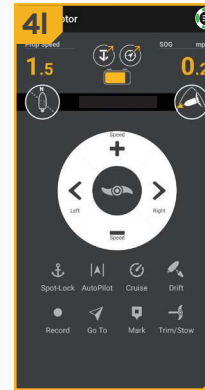
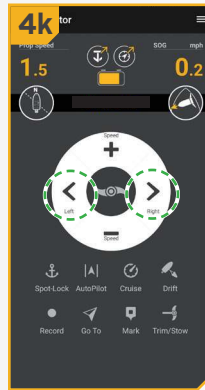

› Straight on Deploy

Minn Kota recommends setting the Keel Offset when the position of the Lower Unit is parallel with the Keel. Save the Keel Offset before exploring the Straight on Deploy feature. Straight on Deploy uses the position recorded in Keel Offset to know where to position the Lower Unit to be parallel with the Keel. When Straight on Deploys is engaged, the trolling motor will deploy the motor and automatically rotate the Lower Unit to the position saved to memory in Keel Offset. By default, the Lower Unit will be parallel to the Keel when the Mount is parallel to the Keel. If the Keel Offset was programmed to another angle, the Straight on Deploy feature will correct the position to match the corrected angle when turned “on”. If straight on deploy is turned “off” the trolling motor will not correct the position in any direction.

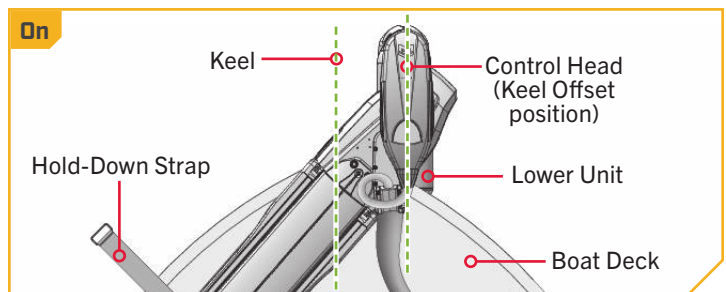
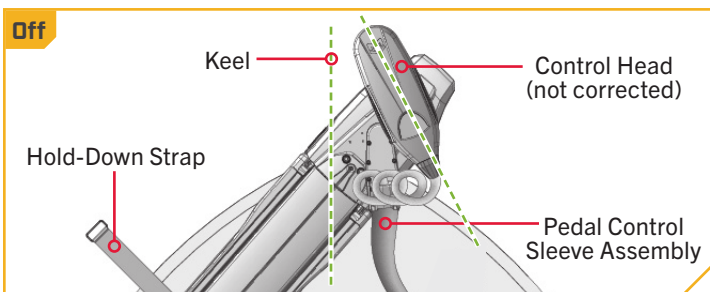

1

- a. Power "on" the trolling motor. When the blue LED next to the Power icon is illuminated, the system is ready.

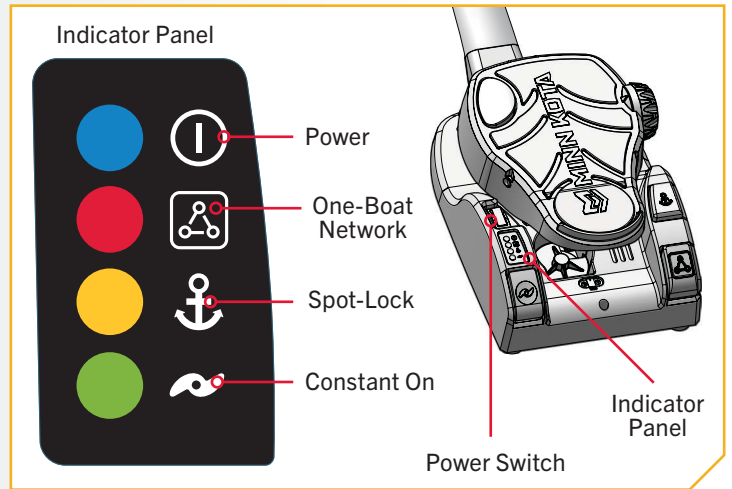

2

- b. Open the One-Boat Network (OBN) app on the mobile device. Make sure the mobile device is paired with the trolling motor.
- c. From the OBN home screen, tap the Motor menu. The Motor menu opens the Motor app home screen.
- d. Before the Motor app home screen will open, tap Agree on the on-screen prompt.

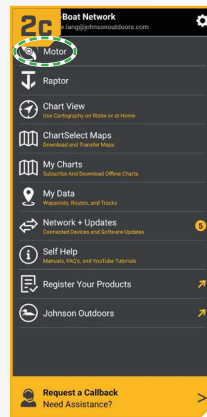

NOTICE: The on-screen prompt will only display once each time the app is launched. If the prompt has displayed, the Motor app home screen appears.

- e. On the Motor app home screen, locate the Motor Setting button in the upper right-hand corner and tap it.

3

- f. In the Motor Settings menu, find the Straight Ahead on Deploy toggle. Tap to turn the toggle "on" and "off". When highlighted yellow the toggle is "on".

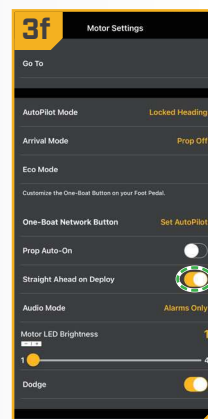
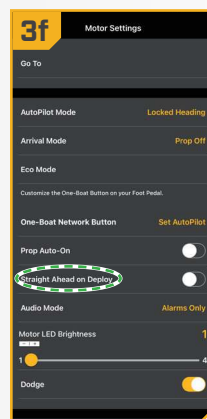

STOW ORIENTATION

Stow Orientation

The Stow Orientation is a term used to describe the lower unit and Prop position when the motor is stowed. The factory default for the lower unit is for the Prop to face outboard (Prop Left) on a Port installation. Setting the Park Position allows the installation to be customized to fit boat positioning for either a Port or Starboard installation. Also, use the setting to configure the Prop left or right to accommodate fishing or trailering applications.

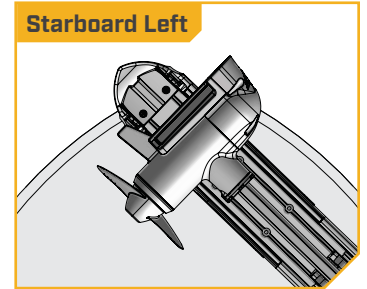
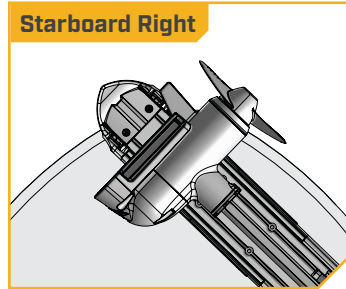
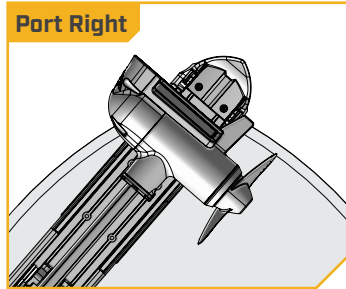
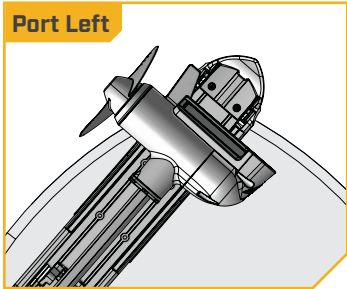

- 1 a. Power "on" the trolling motor. When the blue LED next to the Power icon is illuminated, the system is ready.

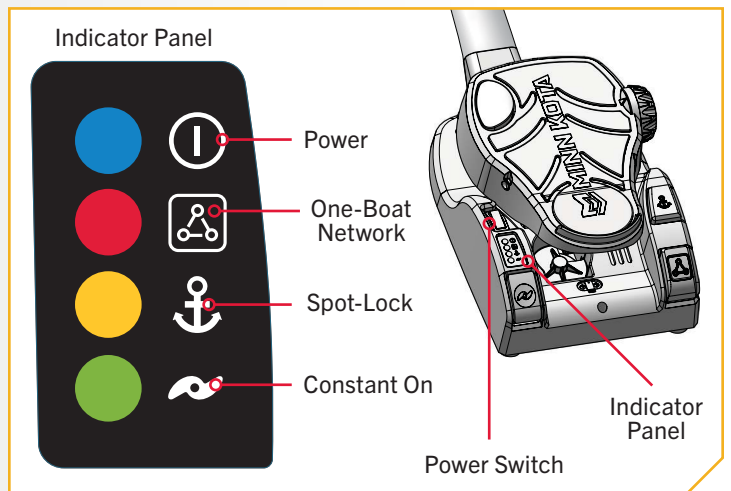

- 2 b. Open the One-Boat Network (OBN) app on the mobile device. Make sure the mobile device is paired with the trolling motor.
- c. From the OBN home screen, tap the Motor menu. The Motor menu opens the Motor app home screen.
- d. Before the Motor app home screen will open, tap Agree on the on-screen prompt.

NOTICE: The on-screen prompt will only display once each time the app is launched. If the prompt has displayed, the Motor app home screen appears.

- e. On the Motor app home screen, locate the Motor Setting button in the upper right-hand corner and tap it.

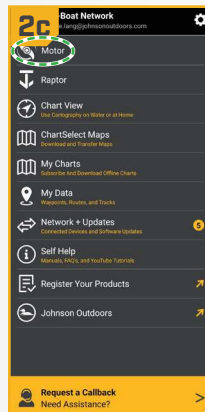

- 3**
- f. In the Motor Settings menu, find and tap Setup and Calibration.
 - g. In Setup and Calibration, find and tap Stow Orientation.
 - h. Set the feature to Prop Right or Prop Left.

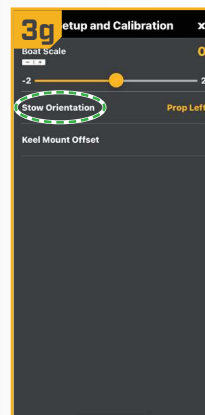
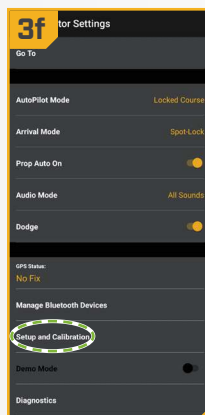

Boat Scale

Trolling motor performance can be impacted by factors including, but not limited to, wind, water conditions, boat specifications, battery health, wiring, etc.

Boat Scale provides a method of adjusting how the trolling motor will perform to account for these and other variables. The Minn Kota trolling motor comes from the factory with Boat Scale set to zero. Boat Scale can be adjusted up (+2) or down (-2) to increase or decrease how the motor control software applies power while using a navigation mode like Spot-Lock.

An example showing the need to reduce Boat Scale would be while using Spot-Lock and the motor is over-correcting or making frequent adjustments. In this case, try reducing Boat Scale -1 to reduce this behavior. If the behavior continues, reduce Boat Scale to -2.

An example showing the need to increase Boat Scale while using Spot-Lock would be the motor is drifting away from its target location frequently or needs help to make corrections. Try increasing Boat Scale to +1 to help improve the trolling motor accuracy in this case. If the behavior continues, increase Boat Scale to +2.

- 1**
- a. Power "on" the trolling motor. When the blue LED next to the power icon is illuminated, the system is ready.

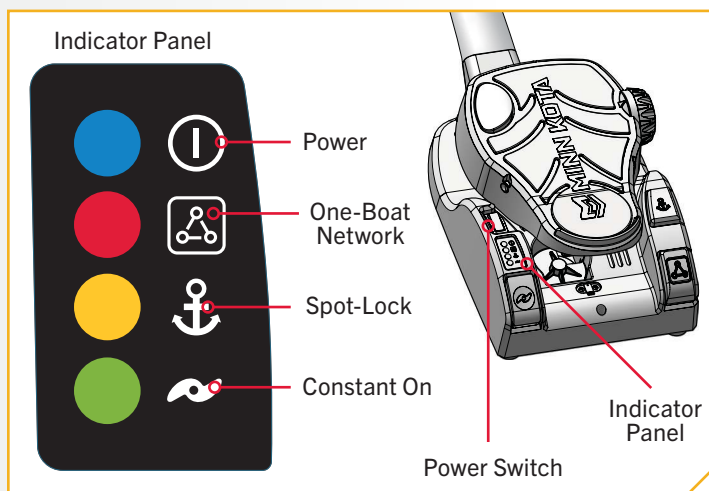

BOAT SCALE

2

- b. Open the One-Boat Network (OBN) app on the mobile device. Make sure the mobile device is paired with the trolling motor.
- c. From the OBN home screen, tap the Motor menu. The Motor menu opens the Motor app home screen.
- d. Before the Motor app home screen will open, tap Agree on the on-screen prompt.

NOTICE: The on-screen prompt will only display once each time the app is launched. If the prompt has displayed, the Motor app home screen appears.



- e. On the Motor app home screen, locate the Motor Setting button in the upper right-hand corner and tap it.

3

- f. In the Motor Settings menu, find and tap Setup and Calibration.
- g. In Setup and Calibration, find and tap the Boat Scale.
- h. Set the feature to increase or decrease Boat Scale.

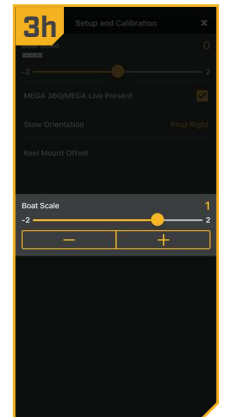
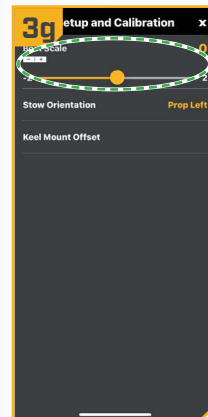
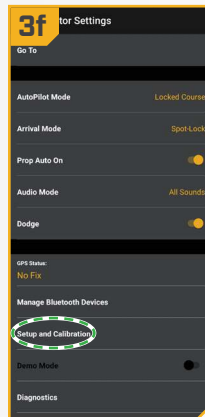

CUSTOMIZE ONE-BOAT NETWORK BUTTON ON THE FOOT PEDAL

› Customize One-Boat Network Button on the Foot Pedal

Minn Kota trolling motors equipped with Advanced GPS Navigation are compatible with devices enabled with the One-Boat Network, such as the Foot Pedal. The One-Boat Network button can be customized through either the One-Boat Network app on a paired mobile device or the Advanced GPS Navigation Wireless Remote. One-Boat Network functions are enabled and disabled through the Foot Pedal with the One-Boat Network  button. The One-Boat Network button on the Foot Pedal can be customized to control the following functions:

| Function | Operation | LED Indication |
|-------------------------------------|-----------------------------------|---|
| AutoPilot (default) | Engage and disengage AutoPilot | Red LED will illuminate when AutoPilot is engaged and stay on until disengaged. |
| Waypoint | Mark a Waypoint | Red LED will illuminate when the One-Boat Network button is pressed and then turn off, signaling that a Waypoint was marked. |
| Shallow Water Anchor (Raptor/Talon) | Deploy and retract a Raptor/Talon | Red LED will steadily flash when the Shallow Water Anchor is deploying or stowing. Red LED will stay illuminated when the anchor is at any state of deployment, including when it is paused. Red LED will turn off when the anchor is fully stowed. |

- 1
 - a. With the trolling motor on, open the One-Boat Network (OBN) app on the mobile device. Make sure the mobile device is paired with the trolling motor.
 - b. From the OBN home screen, tap the Motor menu. The Motor menu opens the Motor app home screen.
 - c. Before the Motor app home screen will open, tap Agree on the on-screen prompt.

NOTICE: The on-screen prompt will only display once each time the app launches. If the prompt has been displayed, the Motor app home screen appears.

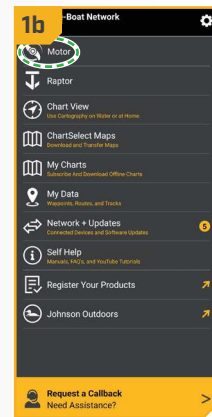
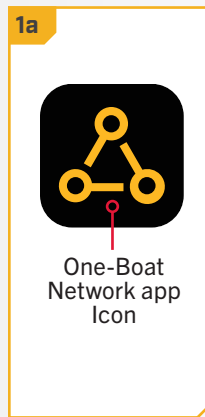

- 2
 - d. On the Motor app home screen, locate the Motor Settings button in the top-right corner and tap it.
 - e. In Motor Settings, locate “One-Boat Network Button” and tap it.
 - f. In the One-Boat Network Button menu, choose the desired function. The radio button next to the selected function will be highlighted.

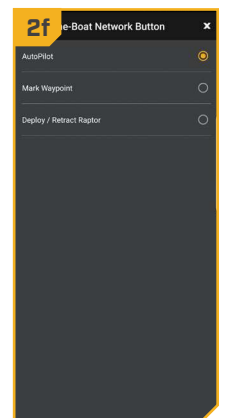
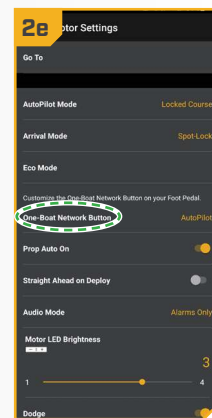
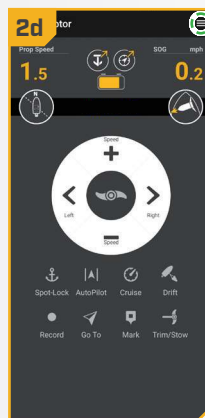

MOTOR WIRING DIAGRAM

ULTREX QUEST

The following Motor Wiring Diagram applies to all Ultrex QUEST models that come factory installed with Advanced GPS Navigation, a Foot Pedal and Sonar. Sonar is either Dual Spectrum CHIRP or Built-in MEGA Side Imaging.

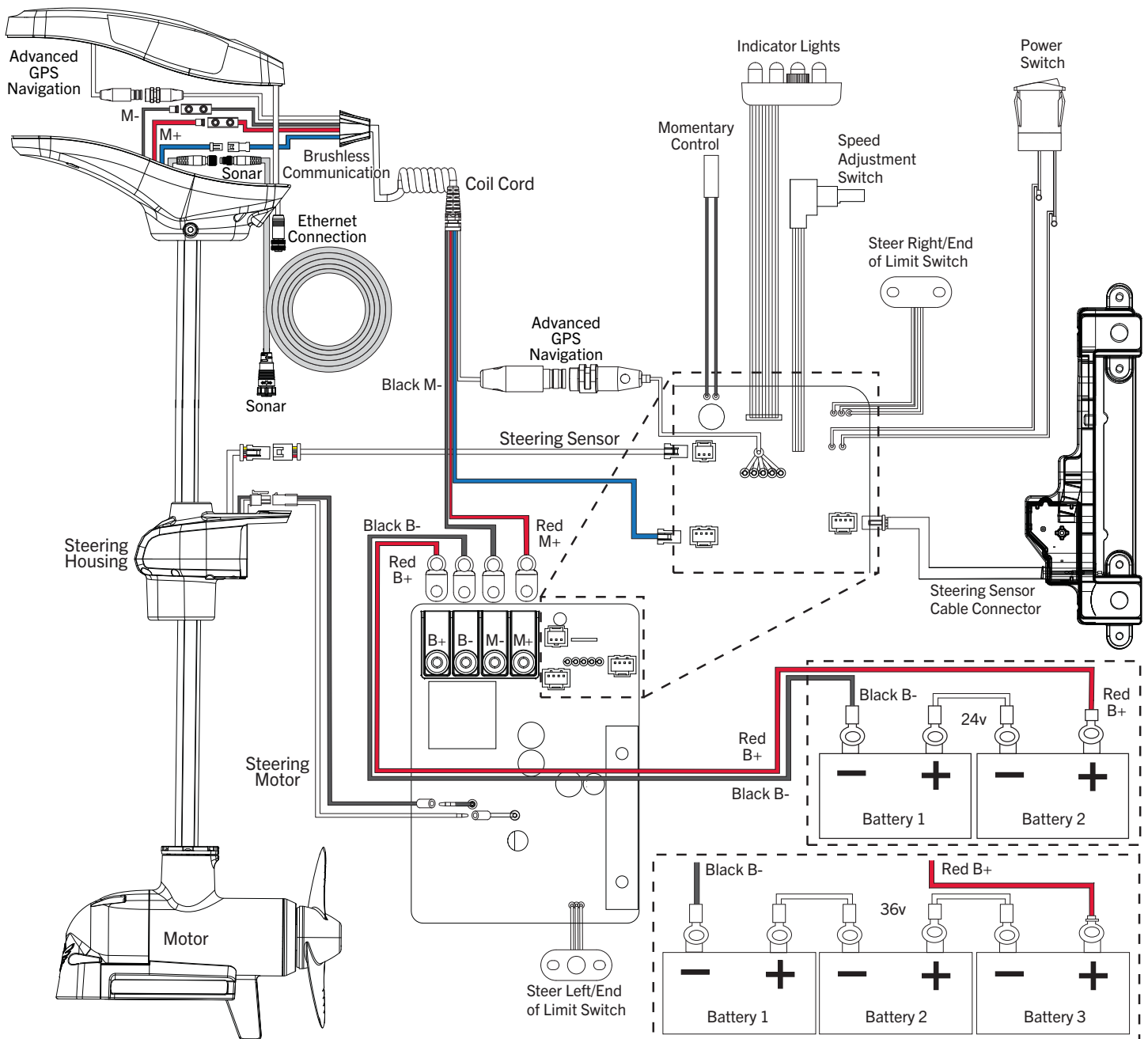

NOTICE: This is a multi-voltage diagram. Double-check your motor's voltage for proper connections. Over-Current Protection Devices are not shown in this illustration.

USING & ADJUSTING THE MOTOR

MOUNT FEATURES

Become familiar with the features of the motor to maximize the capabilities this product offers.

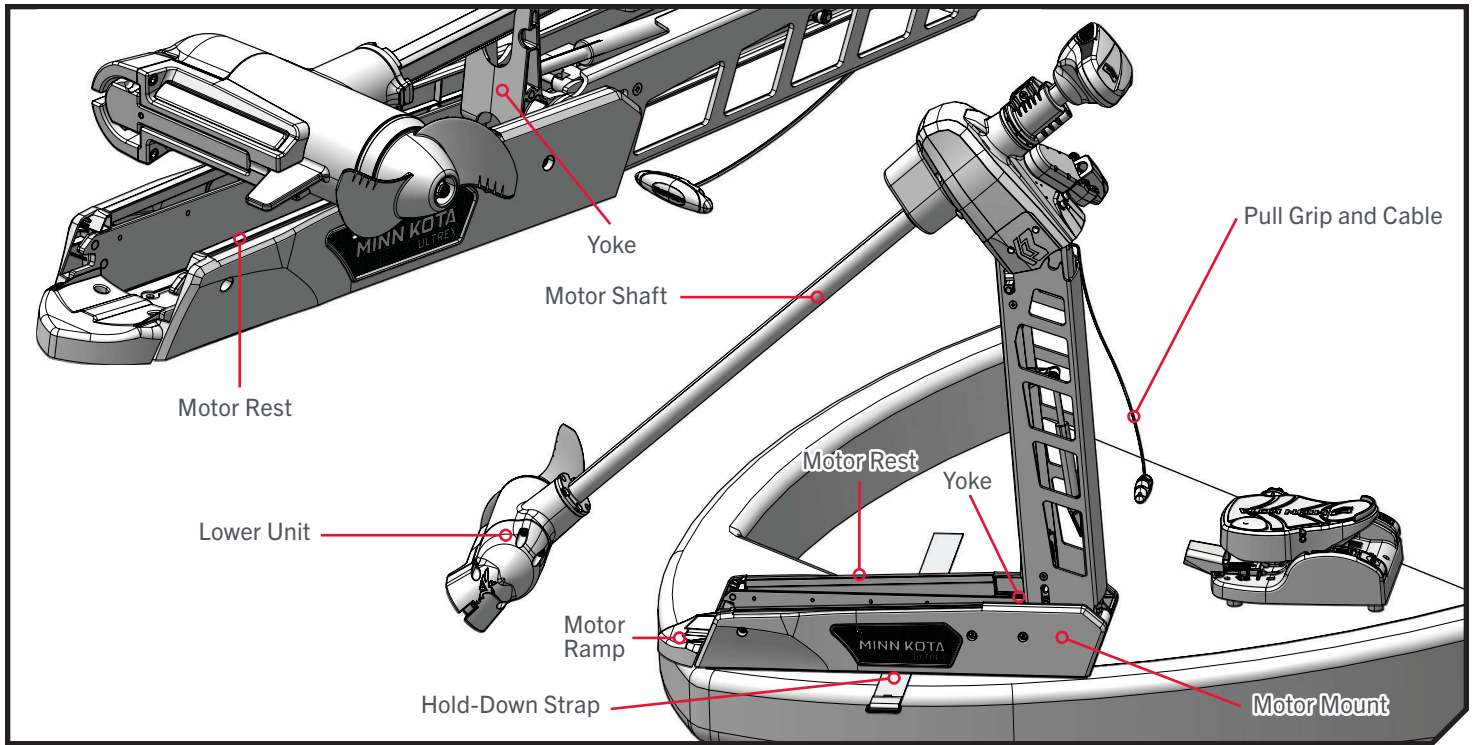

› Motor Mount

The Motor Mount is designed to securely hold the motor in place on the deck of the boat. It functions to stow and lock the motor flat on the deck when not in use by providing secure stowage for transport. The Motor Mount also positions the motor when it is in the deployed position.

› Pull Grip and Cable

The Pull Grip and Cable releases the lock bar on the Motor Mount, which automatically engages when the unit is stowed or deployed into position. The Pull Grip and Cable should be used to assist when both stowing and deploying the unit. Inspect the Pull Grip and Cable during each use and replace when it shows signs of wear.



WARNING

When stowing or deploying the motor, keep fingers clear of all hinges, pivot points and moving parts. Always use the Pull Grip and Cable to stow and deploy the motor to prevent injury.

› Motor Rest and Yoke

The Motor Rest positions the lower unit as it comes into contact with the nose of the mount and guides it onto the Motor Mount. The Yoke sits in the middle of the Motor Rest and captures the motor shaft. The Yoke keeps the lower unit centered on the Motor Rest when in the stowed position.

› Hold-Down Strap

The Hold-Down Strap must be used to place pressure on the motor shaft to hold the Lower Unit tightly against the Motor Rest when stowed. The Hold-Down Strap runs under the Mount and is properly secured when the motor is secured on the Motor Rest and the strap is secured to itself. The Hold-Down Strap should be secured every time the motor is stowed to prevent damage from high wind, rough water or vibrations, including while the boat is trailered.

STOWING AND DEPLOYING THE MOTOR

STOWING AND DEPLOYING THE MOTOR

› To Deploy the Motor

Make sure that the Hold-Down Strap is not secured and then simply pull back and lift the motor off of the mount with the Pull Grip and Cable. Lower the motor into the water using the Pull Grip and Cable. The motor will lock into the deployed position. Once the motor is deployed, make sure it is seated and locked into position.



WARNING

When stowing or deploying the motor, keep fingers clear of all hinges, pivot points and moving parts.

› To Stow the Motor

Pull back and lift the motor out of the water with the Pull Grip and Cable. Guided by the Pull Grip and Cable, the lower unit will drop down onto the Motor Rest. The motor will lock into the stowed position. Once the motor is stowed, make sure it is seated and locked into position. Wrap the Hold-Down Strap over top of the motor shaft to secure the motor. When stowing the motor, it automatically disables the operational function of the foot pedal or paired remote. "Motor stowed" will be displayed on the screen of any applicable remote.

MOTOR ADJUSTMENTS ›

› Adjusting the Lower Unit for a Secure Stow

When the Motor is stowed, the Lower Unit should lie on the Motor Rest Rails just inside the sideplates of the Motor Mount. Minn Kota recommends securing the motor using the following instructions to avoid damage to the motor and shaft from vibrations during transport.

1

- a. Before transporting the boat over water or land, stow the motor to determine where the Lower Unit rests on the Mount.

NOTICE: The correct positioning of the Lower Unit will place it directly on the Motor Rest located on the Motor Mount.

- b. If the Lower Unit does not sit on the Motor Rest, deploy the motor so the Depth Collar can be unlatched and the motor can be adjusted to allow it to lie on the Motor Rest.

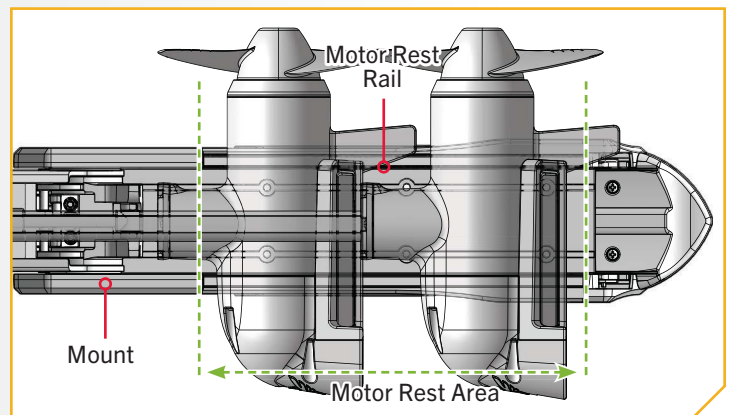
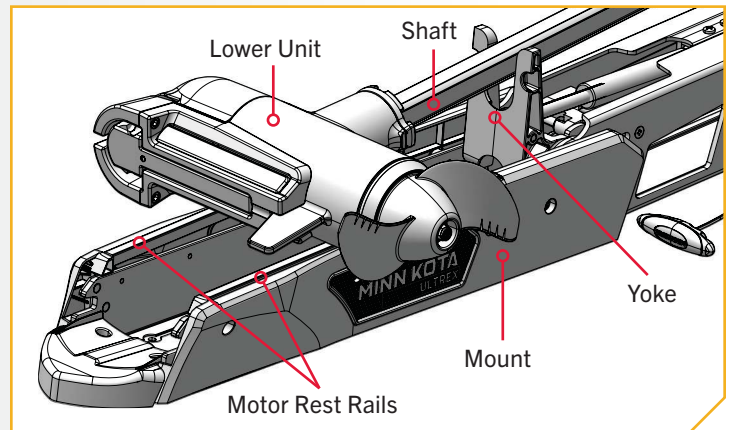

CAUTION

The Lower Unit should be placed on the Motor Rest Rails within the Motor Rest Area every time the motor is transported. If the Lower Unit is improperly placed, either above or below the Motor Rest Area, the Shaft will be incorrectly captured in the Yoke and damage to the Lower Unit or Shaft will occur. Failure to follow the recommended placement for the Lower Unit will cause damage to the product and void your product warranty.

ADJUSTING THE DEPTH OF THE MOTOR

2

- c. With the motor in the deployed position, firmly grasp the motor Shaft above the Steering Module.
- d. Locate the Depth Collar on the Shaft. While holding the Shaft in place, unlatch the Depth Collar so that the Shaft can slide freely.
- e. Raise or lower the motor to the desired depth.
- f. Re-latch the Depth Collar to secure the motor in place.
- g. Stow the motor again and confirm that the Lower Unit is resting on the Motor Rest Rails within the Motor Rest Area. If it is not resting in the recommended location, re-deploy the motor and re-adjust until it sits where recommended when stowed.

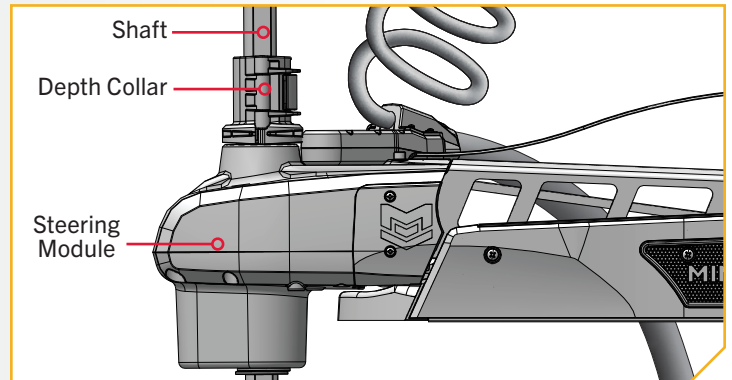

NOTICE: Once the Lower Unit is sitting in the proper position on the Motor Rest, always secure it in place with the Hold-Down Strap.

Adjusting the Depth of the Motor

Once the boat is on the water, it may be necessary to adjust the lower unit up or down to achieve an optimum depth for motor performance. When setting the depth of the motor, be sure that the top of the motor is submerged at least 12" below the surface of the water to avoid churning or agitation of surface water.

1

- a. With the motor in the deployed position, firmly grasp the motor Shaft above the Steering Module.
- b. Locate the Depth Collar on the Shaft. While holding the Shaft in place, unlatch the Depth Collar so that the Shaft can slide freely.

WARNING

The Control Head will create a pinch point if the Depth Collar is unlatched and the Control Head slides to the top of the Depth Collar. Grasp the Shaft and prevent it from sliding all the way down to prevent the pinch point.

- c. Raise or lower the motor to the desired depth.
- d. Re-latch the Depth Collar to secure the motor in place.

NOTICE: Please be sure that the top of the motor is submerged at least 12" below the surface of the water to avoid churning or agitating the water surface.

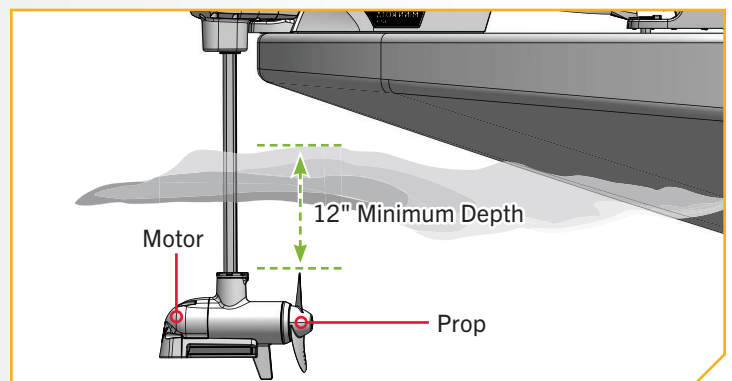
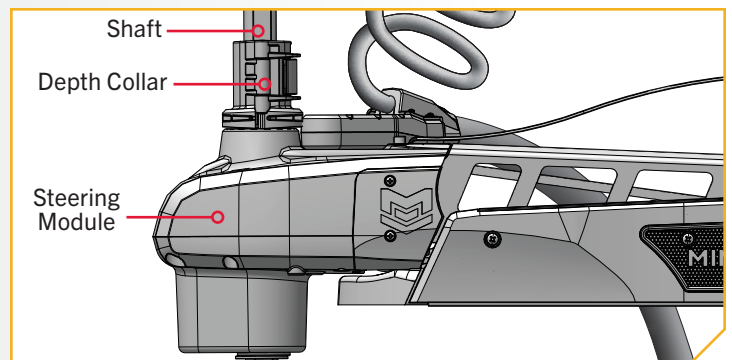

ADJUSTING THE PULL GRIP AND CABLE

Adjusting the Pull Grip and Cable

The length of the Cable on the Pull Grip and Cable can be adjusted based on personal preference. Before beginning the adjustment, the Gas Springs must be disengaged and the Steering Module must be removed. Please refer to the "Removal of the Steering Module" section and follow the procedure to "Disconnect the Gas Springs" and "Remove Motor from Mount". It is important to remove the Gas Springs and the Steering Module in order to access the Cable and associated hardware to make any adjustments.

1

WARNING

Please refer to the "Removal of the Steering Module" section of this manual and follow the procedure to "Disconnect the Gas Springs" and "Remove Motor from Mount". It is important to remove the Steering Module and Disconnect the Gas Springs in order to access the Cable and associated hardware to make the adjustment. Failure to complete these necessary steps will prevent the adjustment from being possible and will result in risk of injury.

- a. With the Gas Springs disconnected and the Steering Module removed, ensure that the mount is in the deployed position.

NOTICE: Observe how the Cable is routed through the Cable Guide, around the Pin, and into the Pins on the Latch Strap Cable Pull Bracket.

- b. Locate the end of the Cable and the Pull Cable Clamp inside the Aluminum Arm of the Mount.

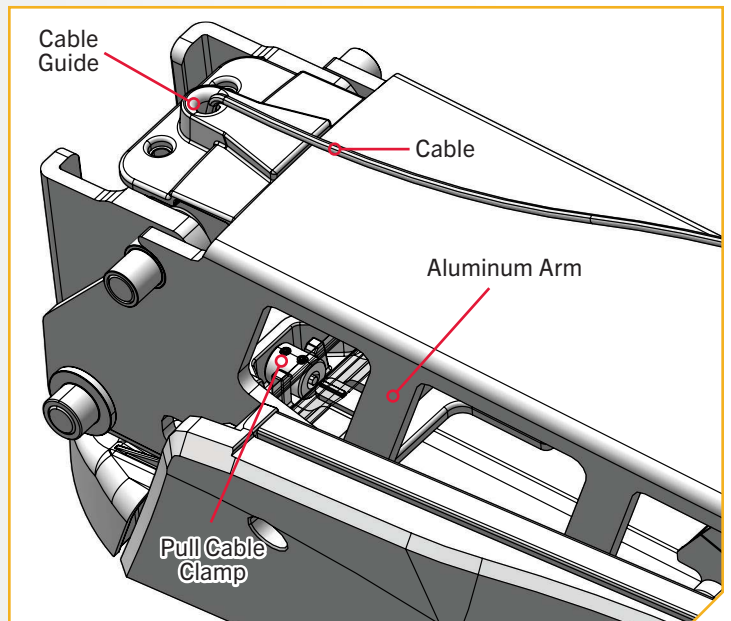
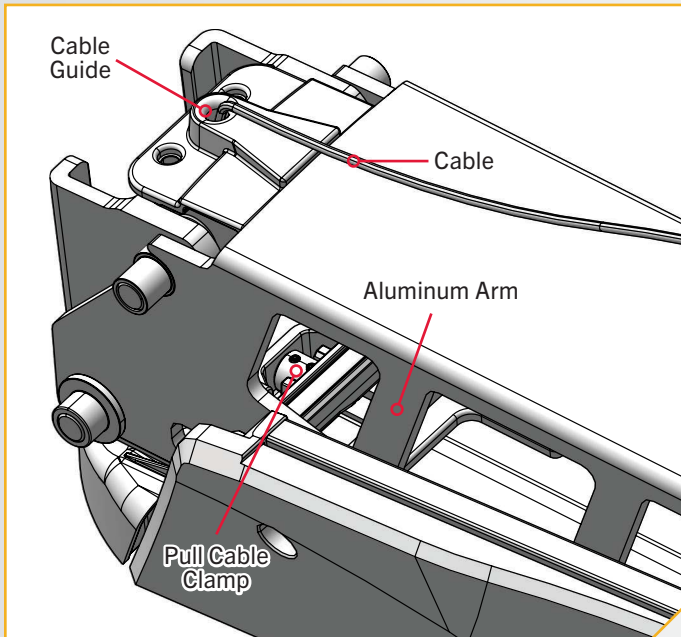
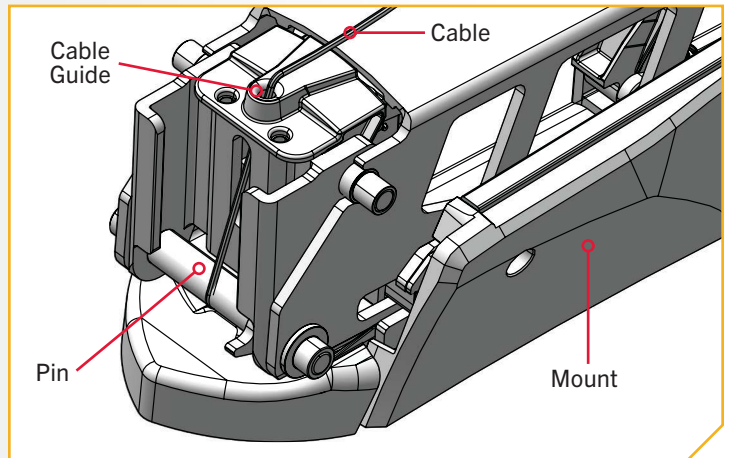

ADJUSTING THE PULL GRIP AND CABLE

2

- c. Grasp the Pull Cable Clamp and Cable and pull it out of the Aluminum Arm.
- d. The Pull Cable Clamp contains two Set Screws. Loosen- but do not remove- these two screws with a 5/64" Allen Wrench until the Cable can slide in the Pull Cable Clamp.
- e. Adjust the Cable to the desired length.
- f. Re-tighten the two Set Screws using the 5/64" Allen Wrench. Tighten the Set Screws to 16-19 in.-lbs. Be sure that the Set Screws are properly seated on the Cable in the Pull Cable Clamp. The Set Screws must provide adequate tension on the Cable to keep it retained in the Pull Cable Clamp during normal operation. When the two Set Screws are properly tightened, they must be recessed slightly below the surface of the Pull Cable Clamp.

NOTICE: Be sure the two Set Screws are tightened adequately. When properly tightened, the two Set Screws must at least be recessed below the Pull Cable Clamp to maintain tension on the Cable in the Pull Cable Clamp during normal operation.

- g. Using a Hack Saw, trim the Cable so there is no more than 1/16" excess beyond the Pull Cable Clamp.

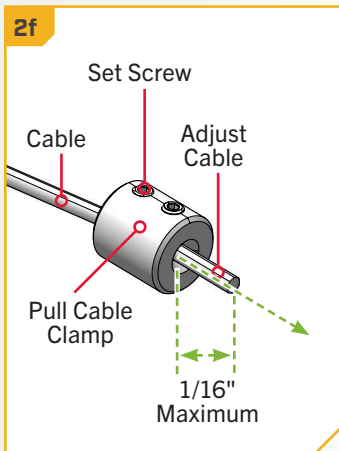
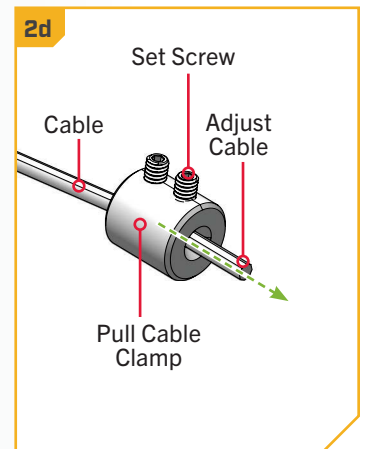
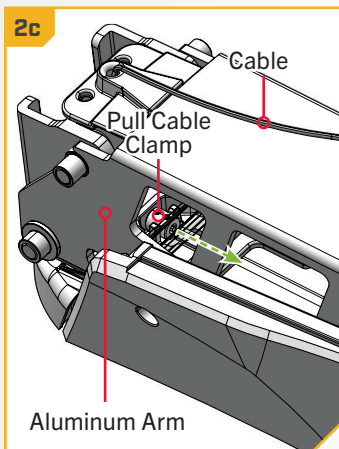

NOTICE: Ensure the Cable is trimmed precisely so that it will fit back into the Pins on the Latch Strap Cable Pull Bracket. If the Cable is too long, the Pull Cable Clamp will not re-seat correctly.

3

- h. Once the Cable has been cut to length, take the Pull Grip and pull the Cable back into place until it is seated against the Latch Strap Cable Pull Bracket. Ensure that the Pull Cable Clamp is seated into the Pins on the Latch Strap Cable Pull Bracket.
- i. After the Cable is in place, refer to the "Removal of the Steering Module" section of these instructions and follow the procedure to "Reassemble the Steering Module."

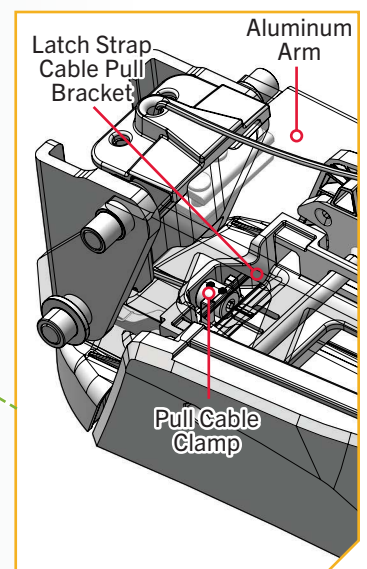
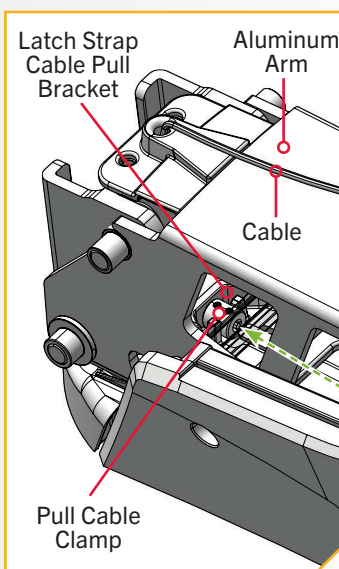
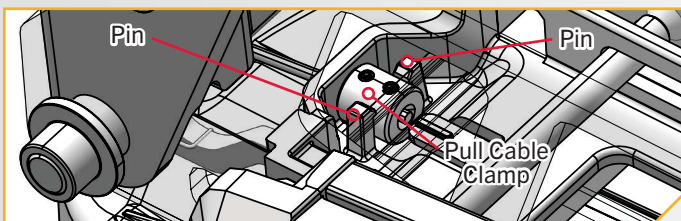

INSTALLING AN EXTERNAL TRANSDUCER

INSTALLING AN EXTERNAL TRANSDUCER

An external transducer is not included with your trolling motor. An external transducer can be installed onto motors that have Advanced GPS Navigation. Installing an external transducer is not recommended for motors with Built-in MEGA Imaging.

- 1
 - a. Mount the External Transducer according to directions provided with the transducer.
 - b. Leave enough slack in the Transducer Cable between the Lower Unit and Control Head to allow the motor to properly stow and deploy.
 - c. Use two tie wrap cables to secure the Transducer Cable to the Shaft just above the Lower Unit and just below the Control Head.
 - d. Run the Transducer Cable through the Coil Cord to the power supply.

CAUTION

The Lower Unit should be placed on the Motor Rest Rails within the Motor Rest Area every time the motor is transported. If the Lower Unit is improperly placed, either above or below the Motor Rest Area, the Shaft will be incorrectly captured in the Yoke and damage to the Lower Unit or Shaft will occur. Failure to follow the recommended placement for the Lower Unit will cause damage to the product and void your product warranty.

NOTICE: For additional details on cable routing, see the "Securing Accessory Cables" section of this manual.

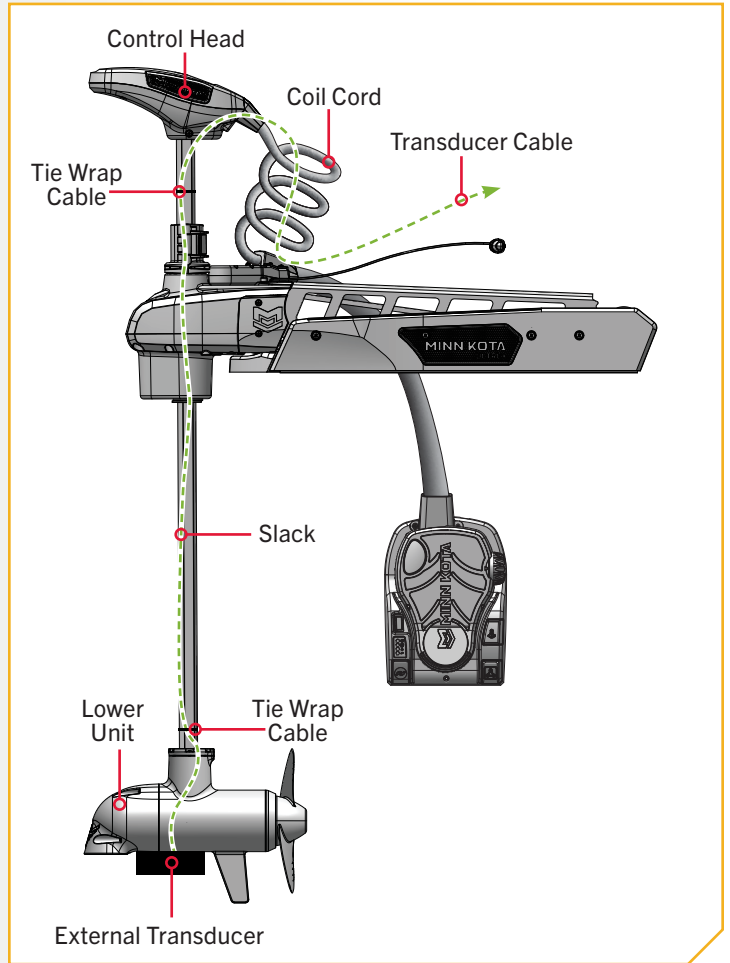

USING THE FOOT PEDAL

CONTROLLING SPEED & STEERING

The Foot Pedal is used to operate the motor, and controls on the Foot Pedal are easy to operate by either foot or hand. The motor can also be controlled by an Advanced GPS Navigation Wireless Remote or the One-Boat Network app, as well as any compatible Minn Kota remote. Please refer to the Advanced GPS Navigation or One-Boat Network (OBN) app Owner's Manual to learn how to control the motor with each.

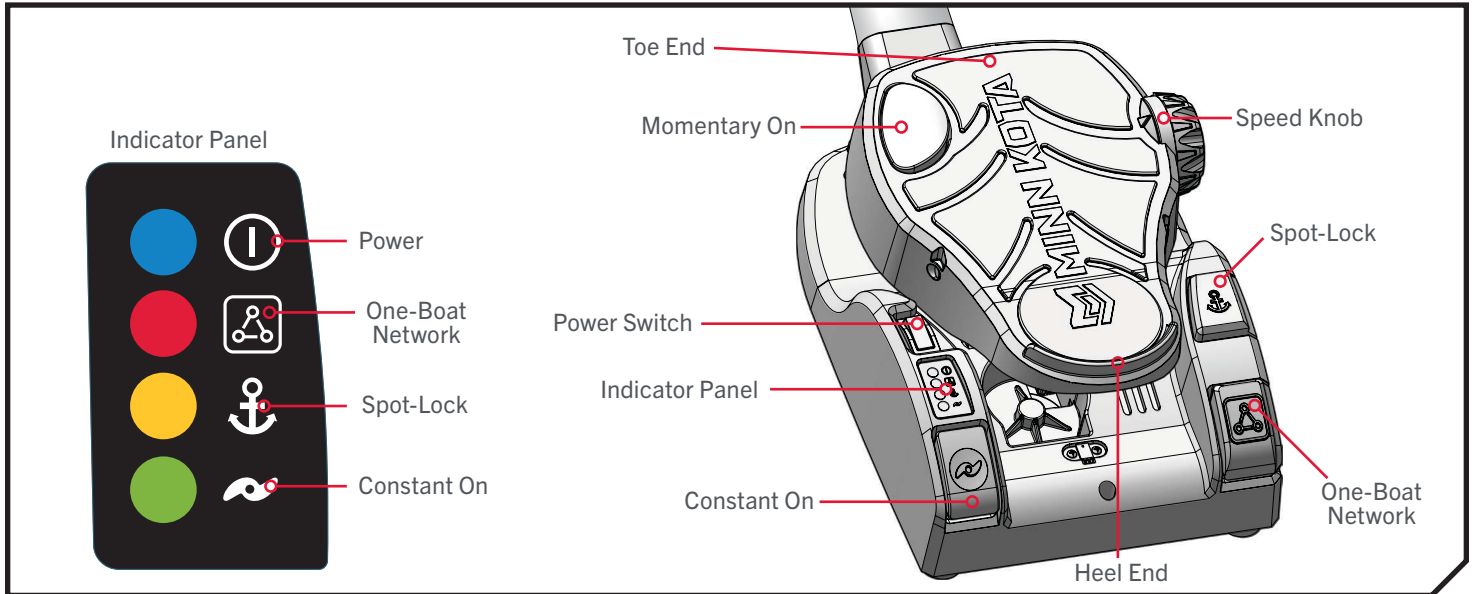

› Power

The Power Switch is located on the left hand side of the Foot Pedal and used to turn the power on and off. The blue LED next to the Power icon (ⓘ) on the Indicator Panel is illuminated when the power is on. Do not try to steer this motor with the Foot Pedal when it has lost power.

NOTICE: Remember to turn the power off when the motor is not in use to prevent the motor from draining the battery.

› Motor Speed

The Speed Knob is located on the top right side of the Toe End of the foot pedal. Turn the Speed Knob clockwise to increase speed and counter-clockwise to decrease speed. Speed can also be adjusted using the remote.

› Momentary Motor Operation

In Momentary Motor Operation, the Prop will only run while downward force is applied to the Momentary On button. The Momentary On button is located on the top left Toe End of the Foot Pedal. Applying downward pressure to the Momentary On button will turn the Prop on. The motor will then run at the speed set by the Speed Knob. Removing downward force to the Momentary On button will turn the Prop off. No indicator LED is associated with the Momentary On button.

› Constant Motor Operation

To switch to Constant Motor Operation, press the Constant On button. The Constant On button is located on the bottom left Heel End of the foot pedal and is labeled on the foot pedal with a Prop symbol. With Constant Motor Operation engaged, the Prop will continually run, regardless of whether or not force is being applied to the Momentary On button. While in Constant Motor Operation, the Prop will run continuously at the speed set by the Speed Knob, or by the Advanced GPS Navigation Wireless Remote or the One-Boat Network app. The green LED next to the Constant On icon (🐟) on the Indicator Panel will be illuminated when the motor is in Constant Motor Operation.

CONTROLLING SPEED & STEERING



If a propeller encounters an obstruction while either in Momentary or Constant Motor Operation, while the Prop is running, the increased electrical current being generated by the obstruction will signal the motor to decrease the power to the Prop to prevent damage. If a current overload is detected, the prop will be disabled to prevent damage to the motor. In this event, the operator can turn the prop back on after being sure that the obstruction has been cleared.

› Turn Left or Right

Push the Toe End of the Foot Pedal down to turn right and push the Heel End of the Foot Pedal down to turn left. The position and direction of the Steering Head directly corresponds to the position of the motor. When turning left or right, the steering motion will end when the cables controlling the direction of the Steering Head and Motor have come to the end of their range of motion. You must use your foot on the pedal to control the steering direction during manual operation. The Foot Pedal is pressure-sensitive. Applying gradual pressure to either the Toe or Heel End of the Foot Pedal will cause the direction to turn gradually. A higher amount of pressure will turn the unit more quickly in the engaged direction. The direction of the motor can also be controlled with the remote or the One-Boat Network app (OBN). Since the direction of the motor is controlled by pressure applied to the Foot Pedal and the reaction of the cables to the pressure, the motor will not turn straight without applying pressure to the Foot Pedal either manually or with the remote to align the cables to engage the motor to steer it straight. Due to the Steering Lock feature, the Steering Head and Motor will remain at the last steered position. Turning left or right can also be controlled by the Advanced GPS Navigation Wireless Remote or the One-Boat Network app. Refer to the corresponding Owner's Manuals to learn more.

| |
|---|
|  CAUTION |
| Make sure that the Power switch is turned off when the motor is not in use. If the motor control is left on and the Prop rotation is blocked, severe motor damage can result. |
| For safety reasons, disconnect the motor from the battery/batteries when the motor is not in use or while the battery/batteries are being charged. |
| Moving parts can cut or crush. Avoid pinch points when operating the Foot Pedal. |

› Steering in Reverse

The Control Head always indicates the direction of travel. To reverse the direction of travel, turn the Control Head in the complete opposite direction of its current location. Keep in mind the steering motion will end when the cables controlling the direction of the Control Head have come to the end of their range of motion.

› Spot-Lock

The Spot-Lock button is located on the right side of the Foot Pedal and is labeled with an anchor symbol. When the Spot-Lock button is pressed, the location of the motor is recorded to memory. The yellow LED next to the Spot-Lock icon  on the Indicator Panel is illuminated when Spot-Lock is engaged. To engage Spot-Lock press the Spot-Lock button, to disengage, press the Spot-Lock button again. When engaging Spot-Lock, a tone will be emitted. When disengaging Spot-Lock with the Spot-Lock button, no tone will be emitted. Steering the motor with the Foot Pedal or adjusting the speed using the Speed Knob will cancel Spot-Lock and a High-Low, High-Low, High-Low tone will be emitted. Spot-Lock can also be controlled with the remote. For more specific directions on how to use Spot-Lock, please refer to your remote manual.

| |
|---|
|  WARNING |
| You are responsible for the safe and prudent operation of your vessel. We have designed Ultrex QUEST to be an accurate and reliable tool that will enhance boat operation and improve your ability to catch fish. This product does not relieve you from the responsibility for safe operation of your boat. You must avoid hazards to navigation and always maintain a permanent watch so you can respond to situations as they develop. You must always be prepared to regain manual control of your boat. Learn to operate your Ultrex QUEST in an area free from hazards and obstacles. |

› One-Boat Network

The One-Boat Network (OBN) button is located on the bottom right corner of the Foot Pedal. It is a customizable button that may change functions based on user selection. Pressing the OBN button will activate the assigned OBN function. The red One-Boat Network (OBN) LED on the Indicator Panel is illuminated when this feature is engaged. Each function has a different LED pattern. AutoPilot is the default OBN function. Please review the “One-Boat Network” section of these instructions to learn more.

› Steering Lock

When you take your foot off Ultrex QUEST's Foot Pedal, the motor head remains pointed in the direction you left it. No recoil or readjustment, just easier steering every day.

FOOT PEDAL ADJUSTMENTS ›

› Adjusting the Steering Cable

The steering cable tension is pre-set at the factory but, through normal use, may need occasional adjustment.

- 1**
 - a. The Cable Tension Screw is located at the base of the Foot Pedal on the Toe End. The screw is below the Steering Cable Cover. The tension of the screw can be adjusted using a #3 Phillips Screwdriver.
 - b. Turn the screw clockwise to increase tension and counter-clockwise to decrease tension.

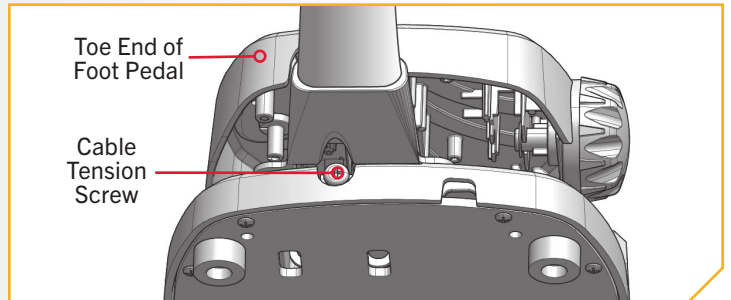
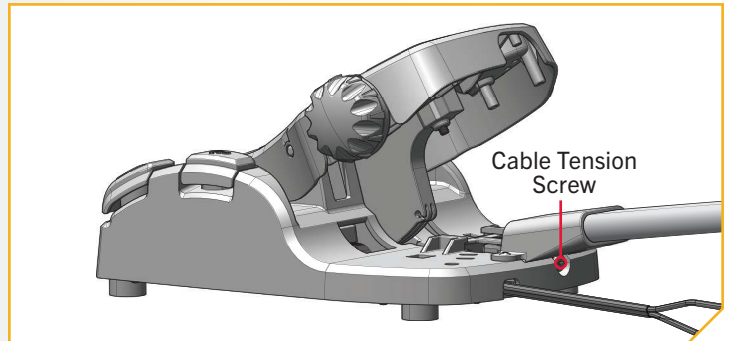

⚠ CAUTION

If the cables become too loose, they may disengage from the Wrap Drum that sits on the Steering Housing or the Cable Pulley in the foot pedal.

⚠ CAUTION

Do not over-tighten the Cable Tension Screw past 10 - 12 in-lbs. Over-tightening the screw will cause damage from excessive tension.

AUTOPILOT

AUTOPILOT AND THE ONE-BOAT NETWORK

AutoPilot on the Advanced GPS Navigation System uses an internal compass to keep the trolling motor pointed in the same compass direction. If the One-Boat Network (OBN) button on the Advanced GPS Navigation System on the Foot Pedal is customized to the AutoPilot function, the button will engage and disengage AutoPilot.

AUTOPILOT MODES

Two different modes of AutoPilot are available, Locked Heading AutoPilot and Locked Course AutoPilot. Both are collectively referred to as AutoPilot. There are distinct differences between the two AutoPilot Modes and how they control the boat. Both Locked Heading and Locked Course AutoPilot are valuable tools anglers can use for accurate and precise bait presentation. Minn Kota highly recommends getting on the water and trying both Locked Heading AutoPilot and Locked Course AutoPilot in various fishing situations and applications. The AutoPilot mode can be set using the Advanced GPS Navigation Wireless Remote or the One-Boat Network app.

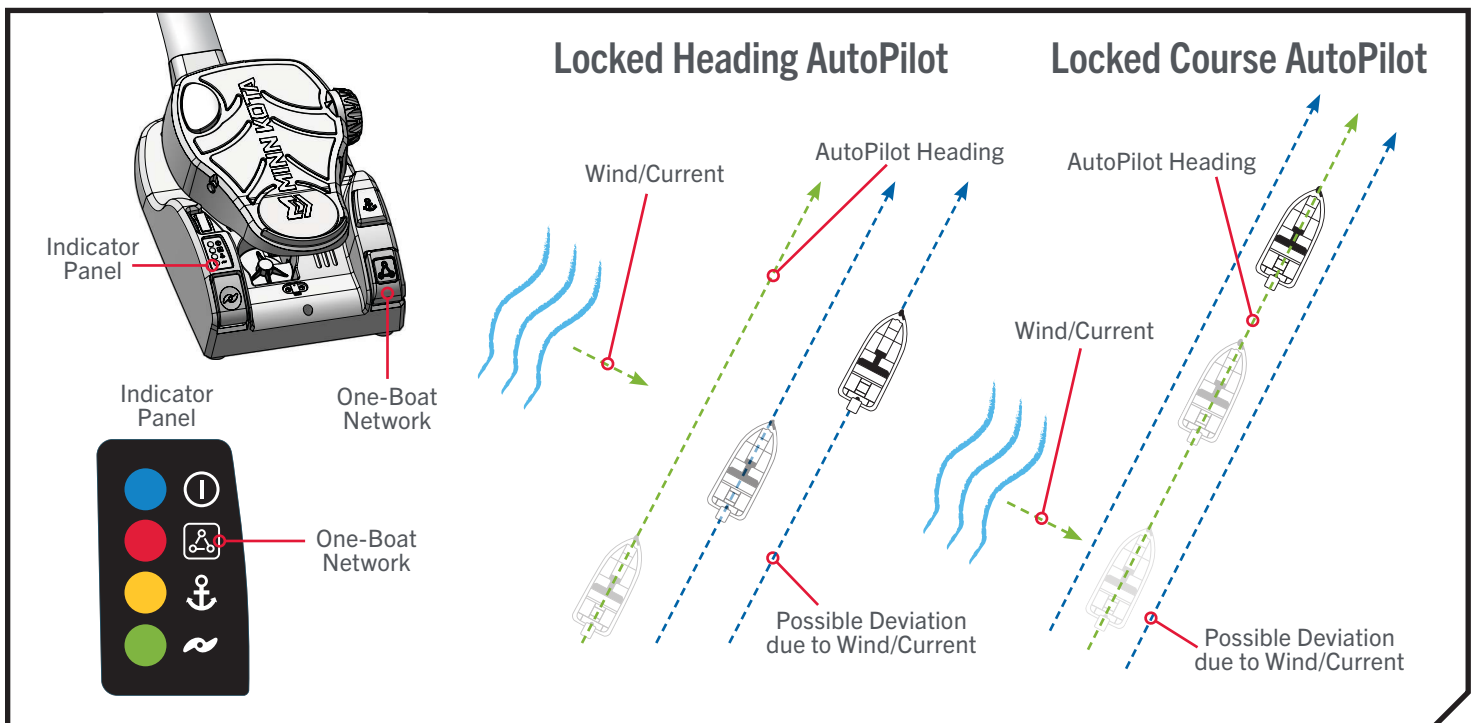

› Locked Heading AutoPilot

AutoPilot uses an internal compass to provide heading lock. When Locked Heading AutoPilot is on, it keeps the motor pointed in the same compass direction. If a manual steering correction is made, Locked Heading AutoPilot locks onto the new compass heading to which the boat was steered. This method of heading tracking does not take into account external forces such as a side wind or currents, which can allow side drift.

› Locked Course AutoPilot

Locked Course AutoPilot uses not only compass heading but also GPS data to correct for crosswinds, currents, and other external forces to keep the boat on the intended course. When Locked Course AutoPilot is turned on, it creates a course that the trolling motor will follow. When the user steers to a new heading, a new course is created. Locked Course AutoPilot will keep the boat on the course in most conditions. When very extreme conditions exist, such as very strong winds or currents, the trolling motor may not have enough power to control the boat smoothly. In these extreme cases, it may be best to use Locked Heading AutoPilot and let the boat move with the wind or current if the motor is not powerful enough to overcome it.

⚠ CAUTION



This unit uses a magnetic compass to detect the direction of travel. The compass can be adversely affected by magnets or large, ferrous metal objects near (within 12" of) the trolling motor control head.

Obstructions on the Prop may cause excessive vibration of the motor control head. This vibration can cause the compass to wander and erratic steering to occur. Clear the obstruction to return the motor to normal operation.

The trolling motor has automatic steering shutdown for safety. In conditions where an obstruction prevents the trolling motor from turning, or in extremely windy conditions, the automatic steering may stop. Any steering input will reset the system to normal.

› **Toggle AutoPilot On/Off**

1

- a. While the motor is running, AutoPilot can be turned on by pressing the One-Boat Network  button located on the Foot Pedal.
- b. The red One-Boat Network  LED on the Indicator Panel will illuminate when AutoPilot is engaged. While AutoPilot is on, steer the trolling motor as desired.

NOTICE: After steering to a new direction, there is a short delay before the direction is locked in to allow the compass to stabilize. When broad speed changes are made, the AutoPilot heading may change slightly. This is normal.

- c. To turn AutoPilot off, press the One-Boat Network  button.

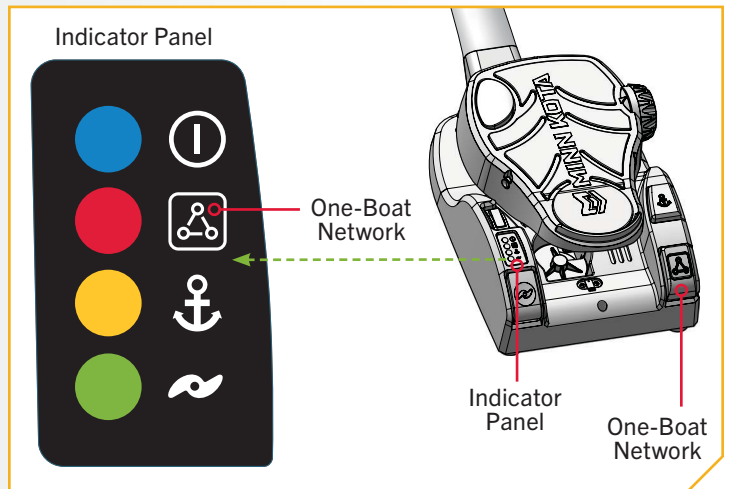

⚠ CAUTION

Power is being supplied to the electronics even when the trolling motor is in the stowed position, when the power switch is "on". The trolling motor should not be stored in this condition for long periods as power is still being applied to all electronics. Always turn AutoPilot off and disconnect your motor from the battery when storing your boat.

WAYPOINTS

WAYPOINTS AND THE ONE-BOAT NETWORK

Waypoints are saved latitude/longitude positions. They mark a position of interest, such as favorite fishing areas, structures, or marker buoys. Waypoints work similarly to Spot-Locks. If the One-Boat Network (OBN)  button on the Foot Pedal is customized to the Waypoint function, the button will mark Waypoints in the Advanced GPS Navigation System when pressed. For more information on working with Waypoints, please see your Advanced GPS Navigation System or Humminbird owner's manual.

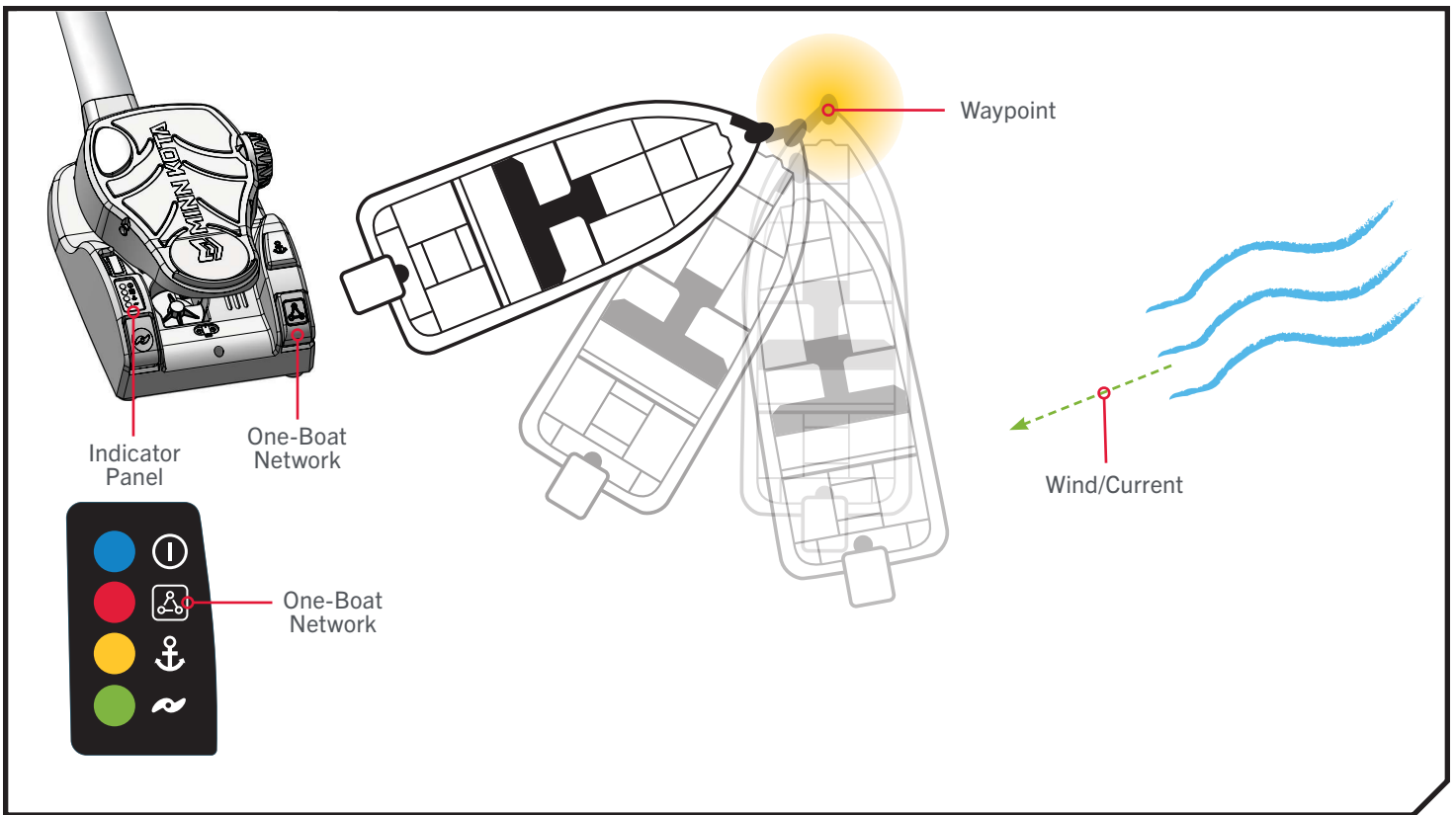

WARNING

Watch for a turning Prop when working with Waypoints. Auto Prop On is set to "off" by default on the Advanced GPS Navigation System. If Auto Prop On is turned "on" the Prop will automatically turn on when a Waypoint is engaged, even if the engagement is accidental. A turning Prop can cause injury. If Auto Prop On is turned "off", the Prop must be enabled before the boat will begin navigating to a Waypoint.



» Mark a Waypoint

1

- a. While the trolling motor is running, mark a Waypoint by pressing the One-Boat Network  button. The red One-Boat Network  LED on the Indicator Panel will briefly illuminate and then turn off to indicate a Waypoint is marked.

NOTICE: Please see the One-Boat Network section of these instructions to learn how to customize the function of the One-Boat Network button on the Foot Pedal.

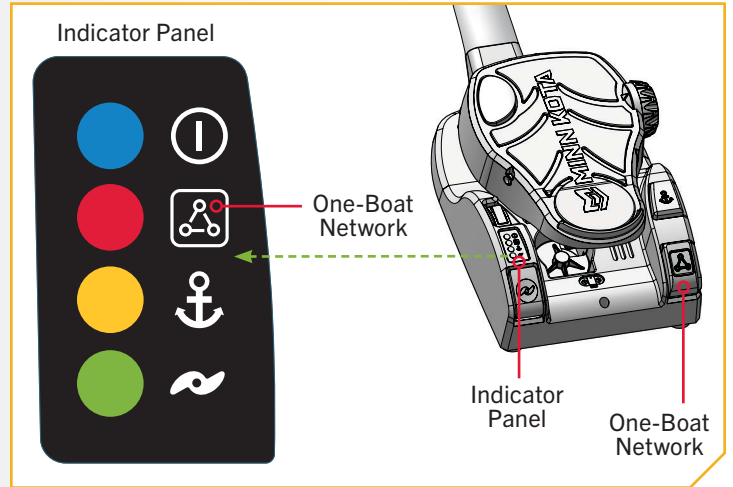

SHALLOW WATER ANCHOR

SHALLOW WATER ANCHOR CONTROL AND THE ONE-BOAT NETWORK

The One-Boat Network allows for control of a Shallow Water Anchor (SWA) when one is paired with the Advanced GPS Navigation Bluetooth Network. SWAs that can pair with the Advanced GPS Navigation system include the Minn Kota Bluetooth enabled Raptor and Talon. For more information on how to pair the SWA with the Advanced GPS Navigation system, please see the Raptor or Talon Owner's Manual.

When two Raptors are paired together or two Talons are paired together, the anchor selected and controlled by the Foot Pedal can be Port, Starboard or both. To change the selection of which anchor is selected, use the remote or app paired to the Shallow Water Anchor.

WARNING

Be sure that the Raptor/Talon is clear of obstructions and persons while deploying or retracting. Take care that neither you nor other persons approach the Raptor/Talon too closely while operating, neither with body parts nor with objects. The Raptor/Talon is powerful and may endanger or injure you or others. While the Raptor/Talon is operating, watch out for persons swimming and for floating objects. Persons who lack the ability to run the Raptor/Talon or whose reactions are impaired by alcohol, drugs, medication, or other substances are not permitted to use this product.

CAUTION

The Talon is equipped with a Deployment Notification Alarm. The Alarm is needed to comply with warranty requirements and when properly installed the alarm will only sound when the ignition key is turned on when the Talon is not fully retracted. Boat control may be affected by a deployed Talon. Take note of the Alarm, and always watch to make sure that the Talon is fully retracted while the boat is operating.

CAUTION

The spaces between the Outer Arm, Inner Arm, Spike and brackets of the Raptor can create a pinch point. Do not come in contact with an area of the Raptor that may cause a pinch point while it is moving in any direction to avoid the risk.

Deploy the Shallow Water Anchor

1

- a. Check to make sure that the Shallow Water Anchor (Raptor/Talon) is powered “on” and paired to the One-Boat Network app.
- b. Locate the One-Boat Network button located on the Foot Pedal and double-press it to deploy the Raptor/Talon.

NOTICE: The One-Boat Network button does not need to be held in to keep the Raptor/Talon deploying. The Raptor/Talon will automatically continue to deploy when the button is double-pressed until it has reached its full deployment, received input to stop, or anchors.

- c. The red One-Boat Network LED on the Indicator Panel will steadily flash when the anchor is deploying and stay on when the anchor is at any state of deployment.

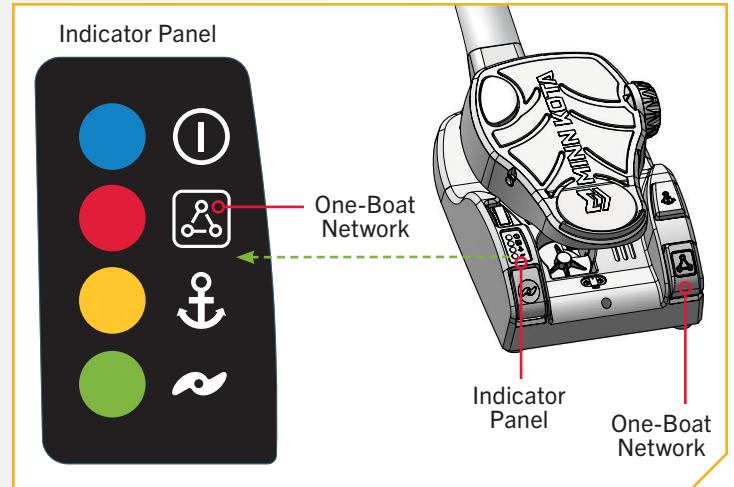

NOTICE: While the Raptor/Talon is deploying, the action can be paused by pressing the One-Boat Network button on the Foot Pedal once.

Retract the Shallow Water Anchor

1

- a. Check to make sure that the Shallow Water Anchor (Raptor/Talon) is powered “on” and paired to the One-Boat Network app.
- b. Locate the One-Boat Network button located on the Foot Pedal and single press it to retract the Raptor/Talon.

NOTICE: While the Raptor/Talon is retracting, the action can be paused by pressing the One-Boat Network button on the Foot Pedal.

- c. The red One-Boat Network LED on the Indicator Panel will steadily flash when the anchor is deploying and stay on when the anchor is at any state of deployment.

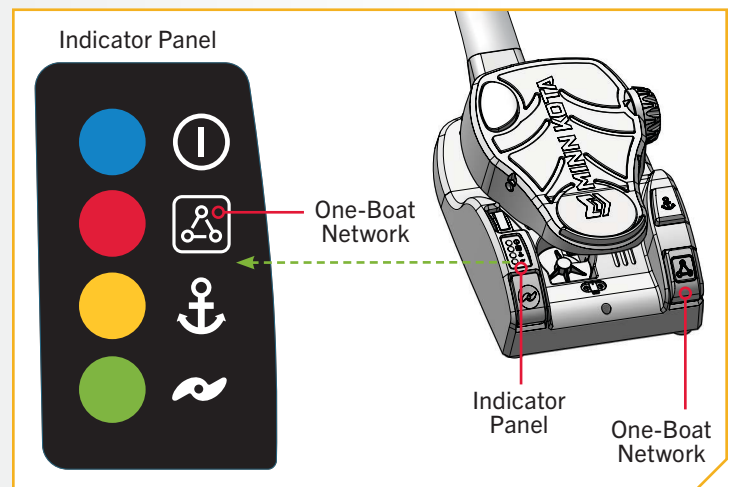

SPOT-LOCK

HOW SPOT-LOCK WORKS

Spot-Lock uses a single point of reference that is recorded when the Spot-Lock  button is pressed. The reference point is a set of GPS coordinates captured at the location of the trolling motor at the moment the button is pressed. This point is recorded and can be saved into one of the Spot-Lock memory locations. Spot-Lock works by recognizing the GPS coordinates and will automatically navigate the boat to keep it at the Spot-Lock location. If your motor recognizes it is not positioned at the Spot-Lock location, it will control motor speed and direction in an attempt to keep the motor on the Spot-Lock. For more specific instructions on using Spot-Lock, please refer to your Wireless Remote owner's manual.

NOTICE: Spot-Lock is based on the location of the trolling motor, not on the location or direction of the boat. Outside forces such as wind and current will cause the boat to move. Spot-Lock will navigate to maintain the motor on the Spot-Lock location regardless of the position of the boat.

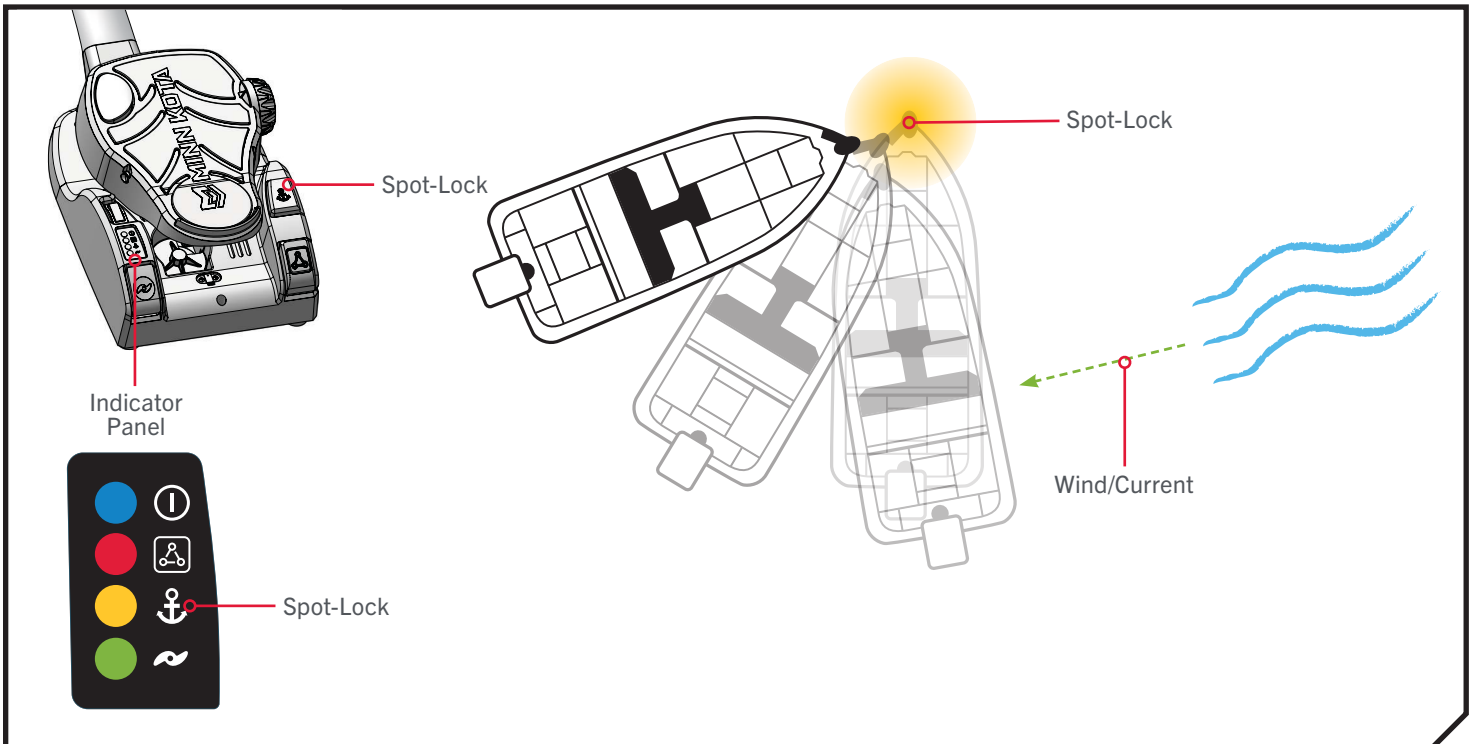

WARNING

Watch for a turning propeller when working with Spot-Lock. The propeller will automatically turn on when Spot-Lock is engaged, even if the engagement is accidental. A turning propeller can cause injury. The propeller will turn "on" for Spot-Lock, regardless of the Prop Auto On setting used on the other control methods in the Advanced GPS Navigation System.



» Toggle Spot-Lock On/Off

1

- a. While the motor is running, Spot-Lock can be turned on by pressing the Spot-Lock  button located on the Foot Pedal. The yellow SPOT-LOCK  LED on the Indicator Panel is illuminated when Spot-Lock is engaged.

NOTICE: In the default Audio Mode, a tone is emitted when Spot-Lock is engaged. If the Audio Mode is set to Alarm Only, a tone will not be emitted when Spot-Lock is engaged. To learn more about Audio Modes, refer to the One-Boat Network app owner's manual.

- b. To disengage Spot-Lock when engaged, press the Spot-Lock button again, or press any button on the Foot Pedal to manually steer the trolling motor.

NOTICE: When disengaging Spot-Lock with the Spot-Lock button on the Foot Pedal, no tone will be emitted. Steering the motor with the Foot Pedal or adjusting the speed using the Speed Knob will cancel Spot-Lock, and a High-Low, High-Low, High-Low tone will be emitted.

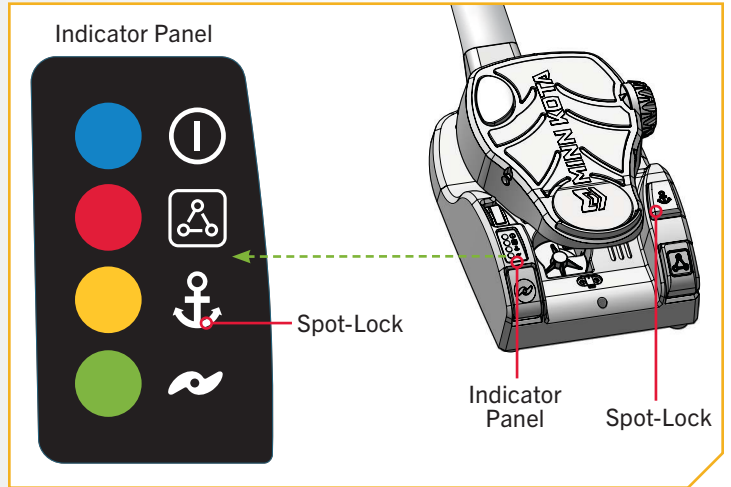

NOTICE: Pressing any button on the Foot Pedal or manually steering the motor with the Foot Pedal will disengage Spot-Lock. Manually steering or adjusting the Prop Speed with a paired remote will also cancel Spot-Lock.

SERVICE & MAINTENANCE

PROP REPLACEMENT

TOOLS AND RESOURCES REQUIRED >

- 9/16" Deep Well Socket

INSTALLATION >

1. a. Disconnect the motor from all sources of power prior to changing the Prop.
b. Hold the Prop and loosen the Prop Nut with a pliers or a wrench.

NOTICE: If the Drive Pin is sheared or broken, you will need to hold the shaft stationary with a flat blade screwdriver pressed into the slot on the end of the shaft while you loosen the Prop Nut.

- c. Remove the Prop Nut and Prop Washer.

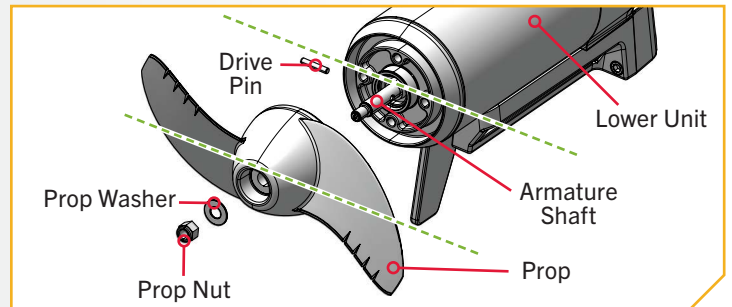

⚠ CAUTION

Disconnect the motor from the battery before beginning any prop work or maintenance.

2. d. Turn the old Prop horizontally and pull it straight off. If Drive Pin falls out, push it back in.

⚠ CAUTION

If the Prop does not readily slide off, take care not to bend the Armature Shaft while removing the Prop by pulling the Prop evenly off the Armature Shaft.

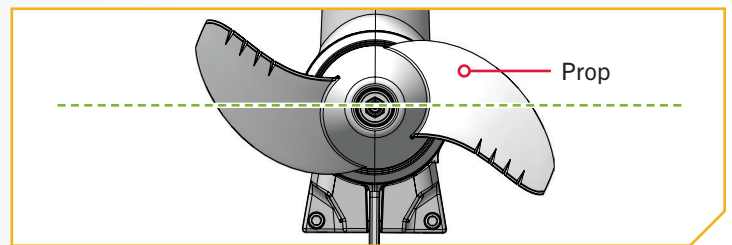

3. e. Align the new Prop with the Drive Pin.
f. Install the Prop Washer and Prop Nut.
g. Tighten the Prop Nut to 25-35 inch-lbs with a 9/16" Deep Well Socket.

⚠ CAUTION

Do not over-tighten as this can damage the Prop.

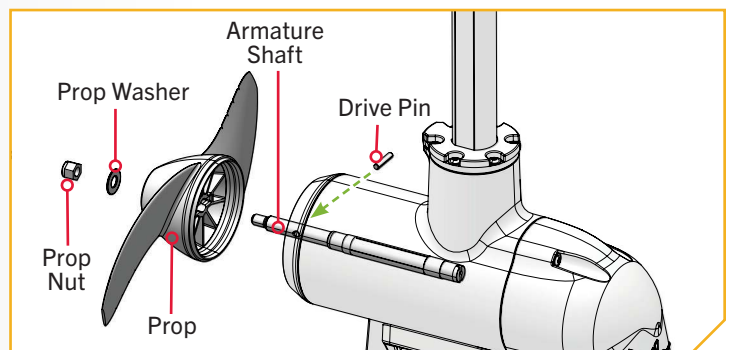

REMOVAL OF THE STEERING MODULE

REMOVAL OF THE STEERING MODULE

› Disconnect the Gas Springs

- 1
 - a. Use the Pull Grip and Cable to disengage the Latch Bar on the Mount.
 - b. With the help of a second person, loosen the Depth Collar and position the motor halfway between the stowed and deployed position. Position the Outer Arm nearly perpendicular to the Base of the Mount.

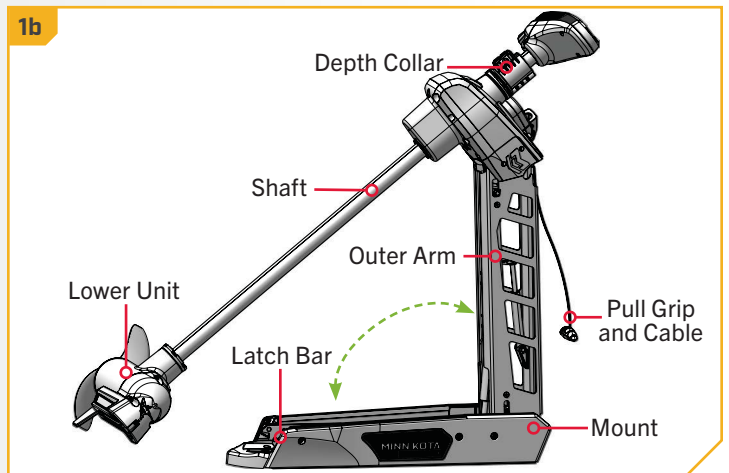
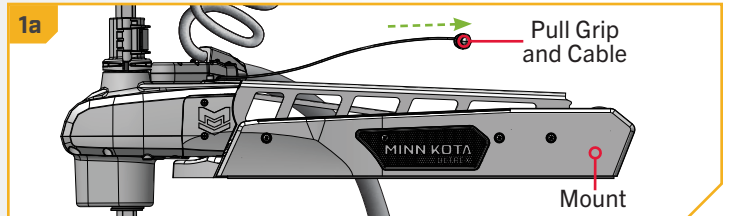

WARNING

Moving parts can cut or crush. The gas assist lift mechanism is under pressure. Disconnect gas springs before removing motor from mount. Do not engage the Pull Grip and Cable until gas springs are disconnected.

WARNING

The gas assist lift mechanism in this unit is under high spring pressure when the motor is in the deployed position. Do not remove the Steering Module assembly from the mount without disconnecting one end of both gas springs. Failure to do this can create a condition where accidental pulling of the Pull Grip and Cable may cause the mount to spring open rapidly, striking anyone or anything in the direct path.

NOTICE: Adjust the Depth Collar on the Shaft as necessary to position the motor. Hold the motor while the two Gas Springs are disconnected.

- 2
 - c. Two Gas Springs are located inside the Outer Arm. Start with the smaller Gas Spring that is positioned closer to the Steering Module.
 - d. Take a #3 Screwdriver and remove the two Pan Head Phillips Machine Screws holding the Bracket at the end of the Gas Spring to the Outer Arm.

NOTICE: Use a #3 Philips screwdriver to remove the screws. Failure to use the recommended tool can cause damage and prevent them from being removed.

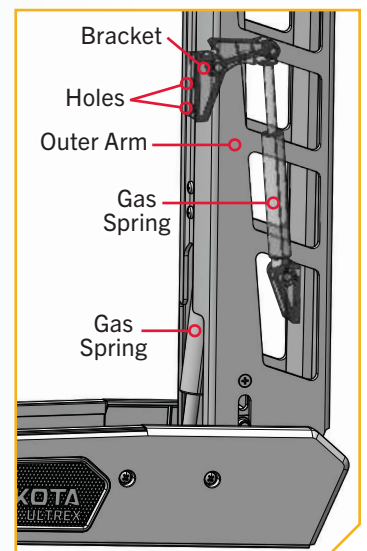
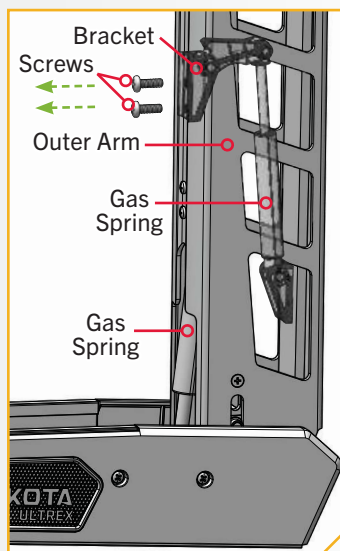

REMOVE MOTOR FROM MOUNT

3

- e. The Bracket attachment for the second Gas Spring is closer to the Boat Deck.
- f. Take a #3 Screwdriver and remove the two Pan Head Phillips Machine Screws holding the Bracket at the end of the Gas Spring to the Outer Arm.

WARNING

Do not damage the Gas Springs. Damage to one or both Gas Springs may affect the motor operation and cause unpredictable Mount movement when reinstalled. Replace Gas Springs if damaged to avoid unexpected operations.

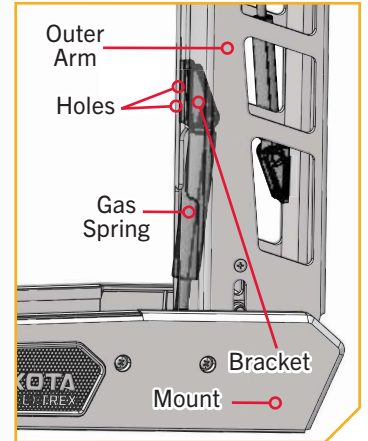
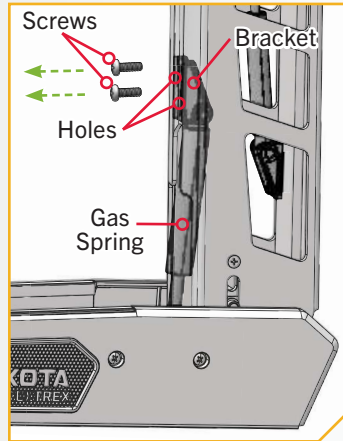

Remove Motor From Mount

1

- a. With the Gas Springs disconnected, place the motor in the deployed position.

WARNING

Moving parts can cut or crush. The gas assist lift mechanism is under pressure. Disconnect gas spring before removing motor from mount. Do not engage the Pull Grip and Cable until gas spring is disconnected.

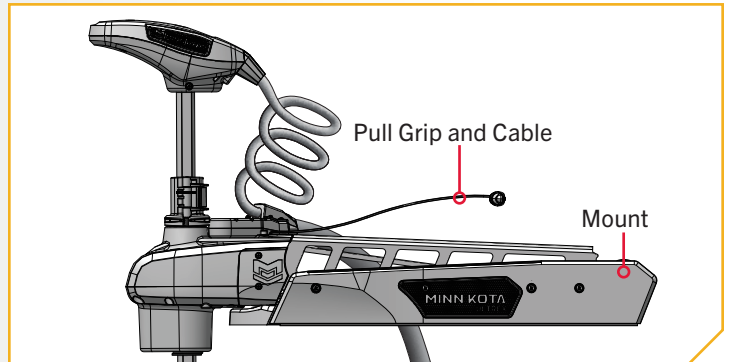

2

- b. Remove the 5/16" Allen Screws with a 1/4" Allen Wrench. The 5/16" Allen Screws are located on the opposite end of the Mount from the hinge that opens and closes when the Mount is stowed and deployed.
- c. Once the Allen Screws and Lock Washers are removed, lift the Steering Module straight up until it is free from the Mount.

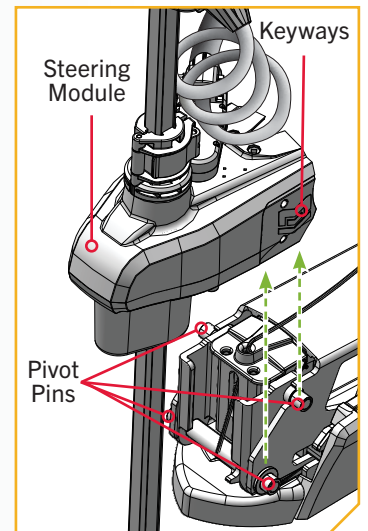
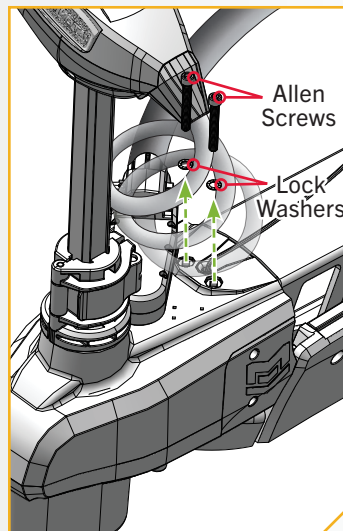

REASSEMBLE THE STEERING MODULE

Reassemble the Steering Module

1

- To reassemble the Steering Module, ensure the mount is in the deployed position.
- Take the Steering Module and align the Keyways on the inside of the Steering Module with the Pivot Pins on the Mount. Do this by positioning the Steering Module above the Pivot Pins on the Mount.
- Lower the Motor Assembly straight down until the Steering Module is seated.



WARNING

Carefully lower the Steering Module into place to avoid creating a pinch point between the Steering Module and Mount.

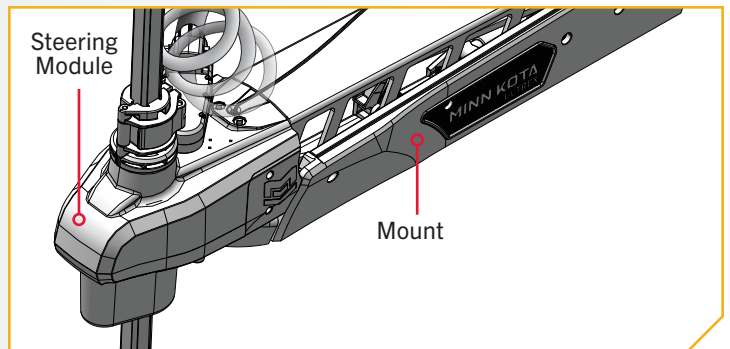
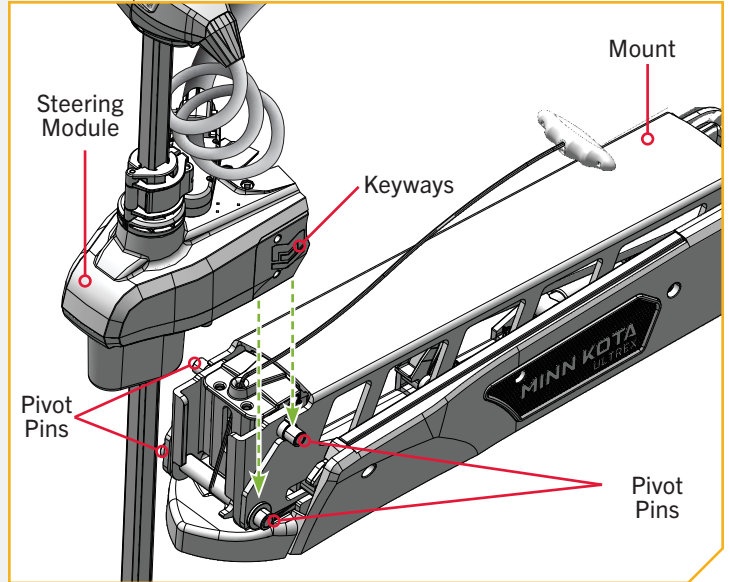

2

- Reinstall the two 5/16" Allen Screws and Lock Washers with a 1/4" Allen Wrench and tighten to 18 to 20 ft-lbs with a Torque Wrench.

NOTICE: The 5/16" Allen Screws must be tightened when installed and periodically tightened to 18 to 20 ft-lbs. This will allow the motor to be stowed properly. Tighten the Allen Screws when the Mount is in the deployed position.

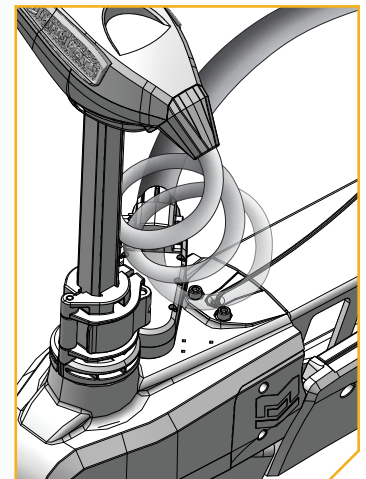
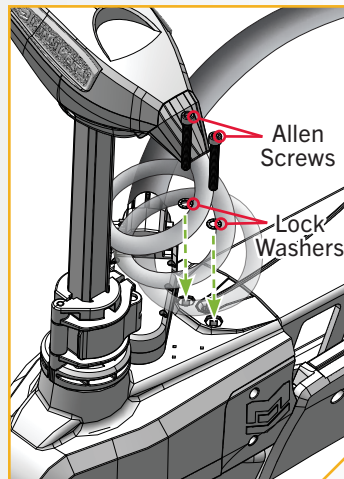

REINSTALLING THE GAS SPRINGS

› Reinstalling the Gas Springs

The Ultrex QUEST contains two Gas Springs inside the Mount. The Gas Springs work to enable Lift-Assist and are located inside the Outer Arm, a part of the Mount. The Gas Springs are not fully assembled and may move around inside the Mount when stowing and deploying the motor. The Gas Springs can become damaged while deploying the motor, and the damage will prevent the Lift-Assist feature from operating correctly once fully assembled. Handle the motor carefully to ensure that the Gas Springs are not damaged in the Mount during reinstallation. With the Steering Module installed on the Mount, and the Mount secured to the boat deck, install the two Gas Springs.

1

- a. Complete the Steering Module assembly prior to reinstalling the Gas Springs. Then use the Pull Grip and Cable to disengage the Latch Bar on the Mount.
- b. With the help of a second person, loosen the Depth Collar and position the motor halfway between the stowed and deployed position. Position the Outer Arm nearly perpendicular to the Base of the Mount.



WARNING

Moving parts can cut or crush. The gas assist lift mechanism is under pressure. Disconnect gas springs before removing motor from mount. Do not engage the Pull Grip and Cable until Gas Springs are disconnected.



WARNING

The gas assist lift mechanism in this unit is under high spring pressure when the motor is in the deployed position. Do not remove the Steering Module assembly from the mount without disconnecting one end of both Gas Springs. Failure to do this can create a condition where accidental pulling of the Pull Grip and Cable may cause the mount to spring open rapidly, striking anyone or anything in the direct path.

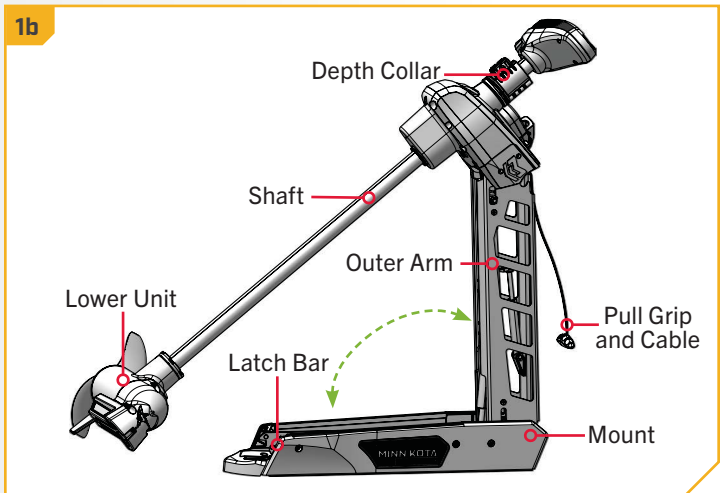
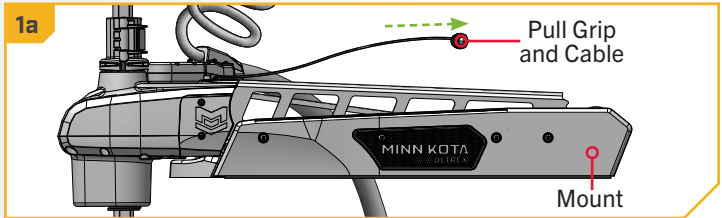

NOTICE: Adjust the Depth Collar on the Shaft as necessary to position the motor. Hold the motor while the two Gas Springs are installed.

REINSTALLING THE GAS SPRINGS

2

- c. Two Gas Springs are located inside the Outer Arm. Once the motor is correctly positioned, the Gas Springs can be secured.
- d. Start with the larger Gas Spring closest to the Boat Deck.
- e. There is a loose Bracket on the end of the Gas Spring with holes and recessed Nylock Nuts. Align the Bracket with the lower two holes in the Outer Arm. Adjust the motor as needed to align the Bracket.
- f. Take two Pan Head Phillips Machine Screws and install them through the holes in the Outer Arm and into the Bracket at the end of the Gas Spring using a #3 Screwdriver. Tighten to 35 in-lbs.

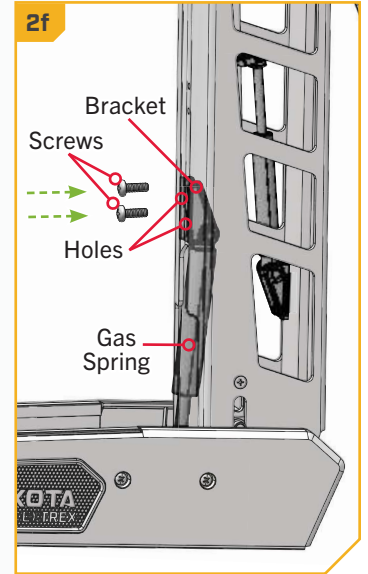
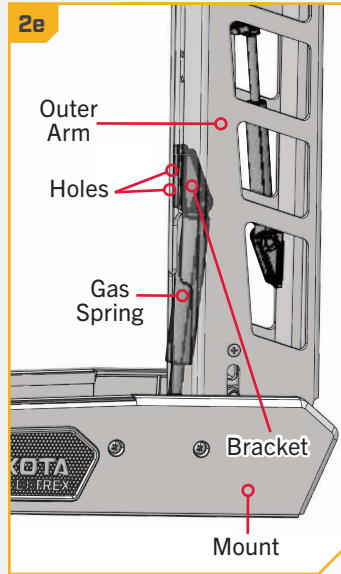

3

- g. The Bracket attachment for the second, smaller Gas Spring sits above the Gas Spring just installed.
- h. Align the Bracket of the second Gas Spring with the upper two holes in the Outer Arm. Adjust the motor as needed.
- i. Take two Pan Head Phillips Machine Screws and install them through the holes in the Outer Arm and into the Bracket at the end of the Gas Spring using a #3 Screwdriver. Tighten to 35 in-lbs.

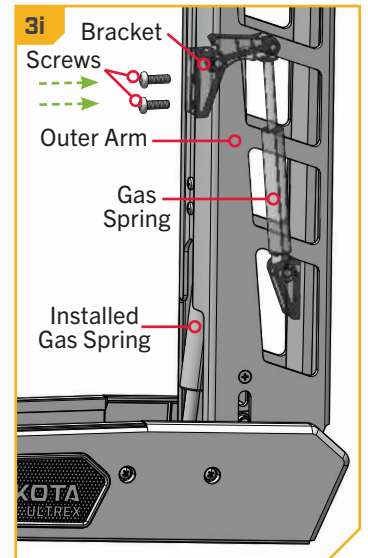
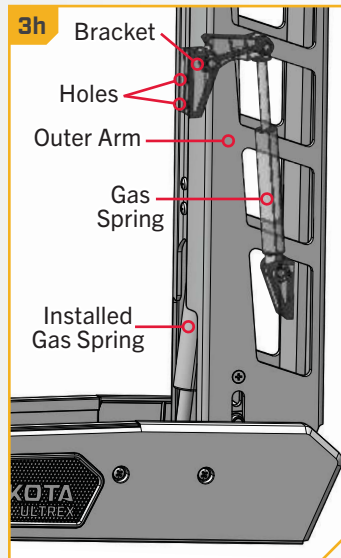

GENERAL MAINTENANCE



GENERAL MAINTENANCE

- After use, the entire motor should be rinsed with fresh water. This series of motors is not equipped for saltwater exposure.
- The composite shaft requires periodic cleaning and lubrication for proper retraction and deployment. A coating of an aqueous-based silicone spray will improve operation.
- The Prop must be inspected and cleaned from weeds and any fishing line after every use. Fishing lines and weeds can get behind the Prop, damage the seals and allow water to enter the motor.
- Verify the Prop Nut is secure each time the motor is used.
- To prevent accidental damage during transportation or storage, disconnect the battery whenever the motor is off of the water. For prolonged storage, lightly coat all metal parts with an aqueous-based silicone spray.
- When using Lithium batteries, it is best to charge them right before using them. Storing Lithium batteries in a fully charged state for long periods of time may cause damage to the batteries. Check with the battery manufacturer for specifics on the battery.
- For maximum battery life of all other batteries except lithium, recharge the battery(s) as soon as possible after use. For maximum motor performance, restore the battery to full charge prior to use. Check with the battery manufacturer for specifics on the battery.
- Keep battery terminals clean with fine sandpaper or emery cloth.
- The Prop is designed to provide operation with very high efficiency. The leading edge of the blades must be kept smooth to maintain the top performance of the Prop. If the edges are rough or nicked from use, restore them to smoothness by sanding them with fine sandpaper.
- Stow the motor after each use to allow water to drain from the Steering Housing. Water that sits in the Steering Housing when the motor is not in use may cause damage.
- The 5/16" Allen Screws securing the Steering Module to the Mount must be tightened when installed and periodically tightened to 18 to 20 ft-lbs. Tighten the Allen Screws when the Mount is in the deployed position.
- The rail covers on the motor rest are intended to be a wear item and may need to be replaced periodically.



TROUBLESHOOTING

1. Motor fails to run or lacks power:

- Check the state of the batteries and replace if necessary. Low battery voltage will cause an error.
- Check battery connections for proper polarity.
- Make sure terminals are clean and corrosion-free. Use fine sandpaper or emery cloth to clean terminals.
- Check battery water level. Add water if needed.

2. Motor loses power after a short running time:

- Check battery charge. If low, restore to full charge.

3. Motor is difficult to steer:

- Loosen the Steering Tension Screw on the Foot Pedal.
- Lubricate the composite shaft.

4. You experience Prop vibration during normal operation:

- Replace the Prop
- Remove and rotate the Prop 180°. See removal instructions in the Prop Replacement section.

5. Experiencing interference with your fishfinder:

- You may, in some applications, experience interference in your depth finder display. We recommend that you use a separate deep cycle marine battery for your trolling motor and that you power the depth finder from the starting/cranking battery. If problems still persist, call our service department at 1-800-227-6433.

6. Experience flashing red LED on the Foot Pedal Indicator Panel

- The trolling motor is communicating that there is an error. Cycle power to the trolling motor. If the LED continues to flash, please contact our service department. If all four LEDs are flashing, the trolling motor is updating. To learn more about updates, please see the Owner's Manual for the One-Boat Network app or the Advanced GPS Navigation Wireless Remote.

NOTICE: For all other malfunctions, visit an Authorized Service Center. You can search for an Authorized Service Center in your area by visiting minnkota.johnsonoutdoors.com, or by calling our customer service number at 800-227-6433.

FOR FURTHER TROUBLESHOOTING AND REPAIR



FOR FURTHER TROUBLESHOOTING AND REPAIR

We offer several options to help you troubleshoot and/or repair your product. Please read through the options listed below.

Buy Parts Online

You can buy parts on-line directly from our website at minnkota.johnsonoutdoors.com. From screws to sideplates, you can order replacement parts for your Minn Kota products.

Frequently Asked Questions

Find answers to general inquiries, battery and rigging installation, and networking scenarios. We have FAQs available on our website at minnkota.johnsonoutdoors.com to help answer all of your Minn Kota questions.

Call Us (for U.S. and Canada)

Our consumer service representatives are available Monday – Friday between 7:00 a.m. – 4:30 p.m. CST at 800-227-6433. If you are calling to order parts, please have the 11-character serial number from your product, specific part numbers, and credit card information available. This will help expedite your call and allow us to provide you with the best consumer service possible. You can reference the parts list located in your manual to identify the specific part numbers.

Email Us

You can contact our consumer service department with questions regarding your Minn Kota products. To inquire, visit minnkota.johnsonoutdoors.com.

Authorized Service Centers

Minn Kota has over 800 authorized service centers in the United States and Canada where you can purchase parts or get your products repaired. Please visit our website to locate a service center in your area.



Scan to visit
Minn Kota
service online.

COMPLIANCE STATEMENTS

ENVIRONMENTAL COMPLIANCE STATEMENT

It is the intention of JOME to be a responsible corporate citizen, operating in compliance with known and applicable environmental regulations, and a good neighbor in the communities where we make or sell our products.

WEEE DIRECTIVE

EU Directive 2002/96/EC “Waste of Electrical and Electronic Equipment Directive (WEEE)” impacts most distributors, sellers, and manufacturers of consumer electronics in the European Union. The WEEE Directive requires the producer of consumer electronics to take responsibility for the management of waste from their products to achieve environmentally responsible disposal during the product life cycle.

WEEE compliance may not be required in your location for electrical & electronic equipment (EEE), nor may it be required for EEE designed and intended as fixed or temporary installation in transportation vehicles such as automobiles, aircraft, and boats. In some European Union member states, these vehicles are considered outside of the scope of the Directive, and EEE for those applications can be considered excluded from the WEEE Directive requirement.

This symbol (WEEE wheelee bin) on product indicates the product must not be disposed of with other household refuse. It must be disposed of and collected for recycling and recovery of waste EEE. Johnson Outdoors Inc. will mark all EEE products in accordance with the WEEE Directive. It is our goal to comply in the collection, treatment, recovery, and environmentally sound disposal of those products; however, these requirements do vary within European Union member states. For more information about where you should dispose of your waste equipment for recycling and recovery and/or your European Union member state requirements, please contact your dealer or distributor from which your product was purchased.

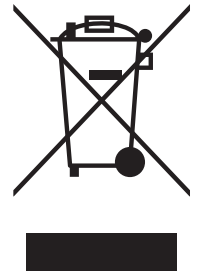

DISPOSAL

Minn Kota motors are not subject to the disposal regulations EAG-VO (electric devices directive) that implements the WEEE directive. Nevertheless never dispose of your Minn Kota motor in a garbage bin but at the proper place of collection of your local town council.

Never dispose of battery in a garbage bin. Comply with the disposal directions of the manufacturer or his representative and dispose of them at the proper place of collection of your local town council.

REGULATORY COMPLIANCE INFORMATION

› Advanced GPS Navigation

For regulatory information on motors that come factory installed with Advanced GPS Navigation, please refer to the Advanced GPS Navigation Owner's Manual online at minnkota.johnsonoutdoors.com.

FCC COMPLIANCE



FCC COMPLIANCE

This device complies with Part 15 of the FCC rules. **Operation is subject to the following two conditions:**

1. This device may not cause harmful interference.
2. This device must accept any interference that may be received, including interference that may cause undesired operation.

Changes or modifications not expressly approved by Johnson Outdoors Marine Electronics, Inc. could void the user’s authority to operate this equipment.

NOTICE: This equipment has been tested and found to comply with the limits for a Class B digital device, pursuant to part 15 of the FCC Rules. These limits are designed to provide reasonable protection against harmful interference in a residential installation. This equipment generates, uses and can radiate radio frequency energy and, if not installed and used in accordance with the instructions, may cause harmful interference to radio communications. However, there is no guarantee that interference will not occur in a particular installation. **If this equipment does cause harmful interference to radio or television reception, which can be determined by turning the equipment off and on, the user is encouraged to try to correct the interference by one or more of the following measures:**

- Reorient or relocate the receiving antenna.
- Increase the separation between the equipment and receiver.
- Connect the equipment into an outlet on a circuit different from that to which the receiver is connected.
- Consult the dealer or an experienced radio/TV technician for help.

INDUSTRY CANADA COMPLIANCE

This product meets the applicable Industry Canada technical specifications. Operation is subject to the following two conditions: (1) this device may not cause interference, and (2) this device must accept any interference, including interference that may cause undesired operation of the device.

ENVIRONMENTAL RATINGS

- Ambient operating temperature range: -10C to 50C
- Ambient operating humidity range: 5% to 95%
- Maximum operating altitude: 10,000 feet

