

# ADVANCED GPS NAVIGATION

## 5

### ITEM(S) NEEDED



- i. If installing directly to a Helix Adapter Cable (Item #9), align the Receptacle on the Ethernet Cable with the Eight Pin Connector on the Helix Adapter Cable provided. Notice the keyed connectors. Tighten the Collar from the Ethernet Cable to secure the connection.

**NOTICE:** Minn Kota provides one Helix Adapter Cable (AS EC QDE - Ethernet Adapter Cable - 720074-1) with every trolling motor equipped with Advanced GPS Navigation.

- j. The Helix Adapter Cable directly connects the Ethernet Cable to a Helix fish finder. Locate the Helix Adapter Cable Keyed Connector on the back of the fish finder. Plug the Helix Adapter Cable into the back of the Helix fish finder to complete the connection.
- k. If your trolling motor has more than one feature that requires connection to an output device, complete the connection for that specific output and then follow the instructions for "Securing Accessory Cables" to complete the Accessory Cable installation.

**NOTICE:** If unsure of what features your trolling motor may be installed with that require connection to an output device, please review the "Identifying Trolling Motor Features And Their Associated Cables" section of this manual.

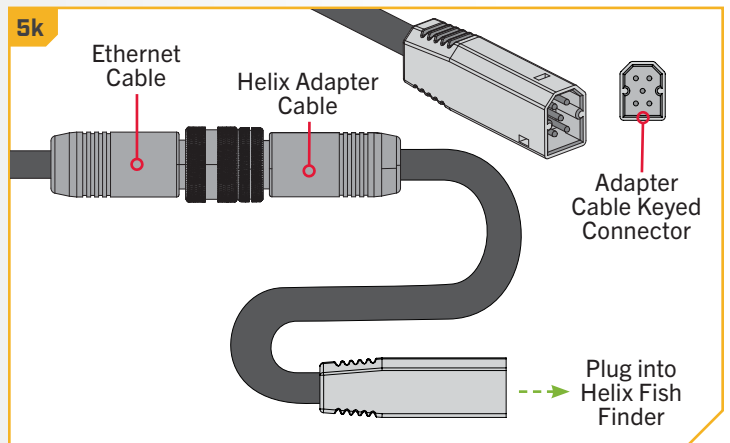
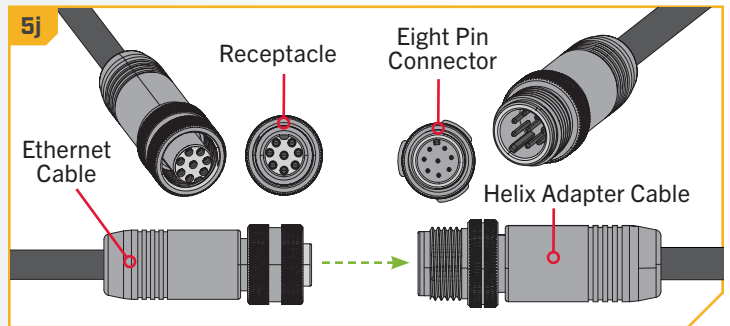

## › Securing Accessory Cables

Before securing the Accessory Cables, please review the "Identifying Trolling Motor Features and Their Associated Cables" section of this document. When identifying features, it is very important to secure the cables if **two or more** connections are present below the Control Head. If only **one** cable is present below the Control Head, this installation was already completed on the trolling motor from the factory. All Accessory Cables that will be used on the trolling motor must be routed and all connections secured before completing the installation in this section. To review how Accessory Cables should be routed and connected, please review the "Dual Spectrum CHIRP," "Built-in MEGA Down Imaging" and "Advanced GPS Navigation" sections of this document.

**NOTICE:** If only one cable is present below the Control Head, this installation is not applicable.

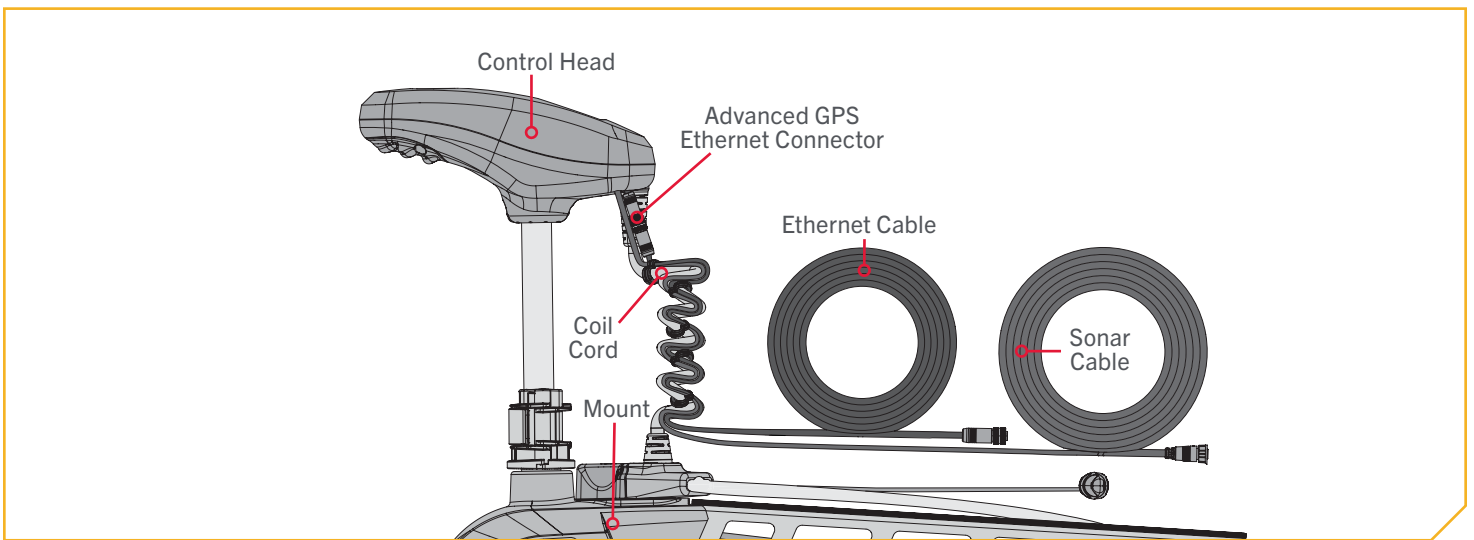

## CAUTION

Failure to follow the recommended wire routing for installed features, if equipped, may cause damage to the product and void your product warranty. Route cables away from pinch points or other areas that may cause them to bend in sharp angles. Routing the cables in any way other than directed may cause damage to the cables by being pinched or severed. Do not over-tighten the clips as it may damage the wires.

**NOTICE:** If replacement Clips (Part No. 2290844) are needed, they can be ordered online at the Minn Kota Parts Ordering Portal at [minnkota.johnsonoutdoors.com](http://minnkota.johnsonoutdoors.com).

# SECURING ACCESSORY CABLES

1

- a. The Ultrex comes from the factory with the Sonar Cable secured to the Coil Cord with five Clips. The Clips are evenly spaced down the Coil Cord from the Control Head to the Mount. To properly install the Ethernet Cable, the Clips need to be opened and the Ethernet Cable secured.
- b. Begin with the Trolling Motor in the deployed position. Locate all 5 Clips along the Coil Cord. Make sure that the Ethernet Cable is connected. Review the "Advanced GPS Navigation" section of this document if unsure that the Ethernet Cable is properly routed and connected. The Ethernet Cable should run parallel to the Sonar Cable down the Coil Cord.

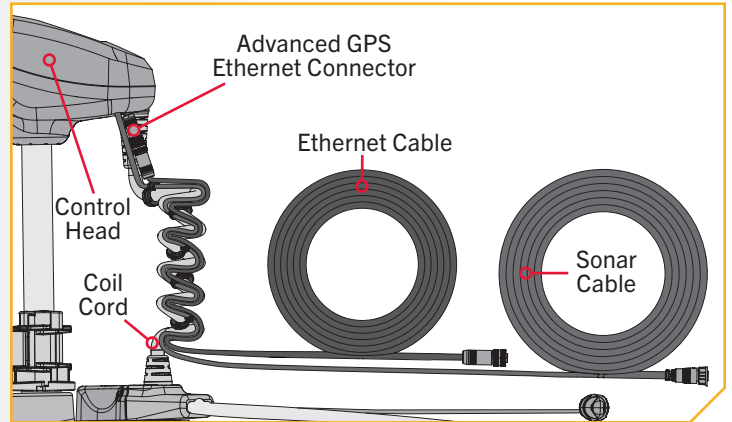

2

- c. Locate the first Clip below the Control Head. It should be securing together the Coil Cord and the Sonar Cable.
- d. To open the Clip, push each side of the Clip in opposite directions so that the hook holding the Clip together unlatches.
- e. Look at the geometry of the Clip and notice that the lobes are molded for a specific wire size. With the Ethernet Cable running parallel to the Sonar Cable and Coil Cord, place the Ethernet Cable in the Clip with the Coil Cord and Sonar Cable. Make sure that the Ethernet Cable sits in the appropriate Lobe of the Clip.
- f. Make sure the cables are running parallel and are not twisted or kinked. With all of the Cables captured, press the Clip securely closed.
- g. Repeat the installation of the Ethernet Cable for all five Clips. Make sure the cables are running smoothly between all five Clips. At the end of the installation, the Clips should be evenly spaced down the Coil Cord and the cord should contain about one Clip per coil on the Coil Cord.

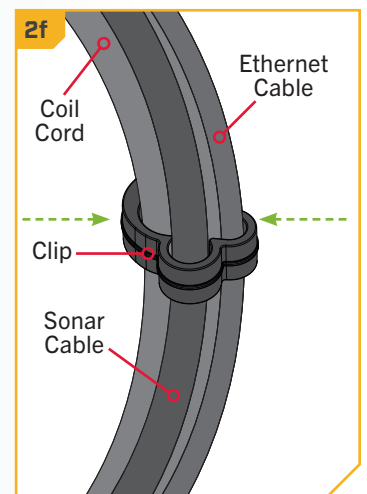
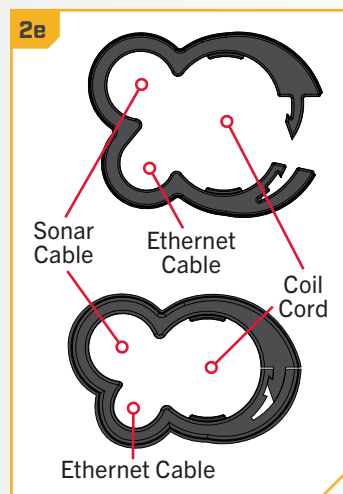
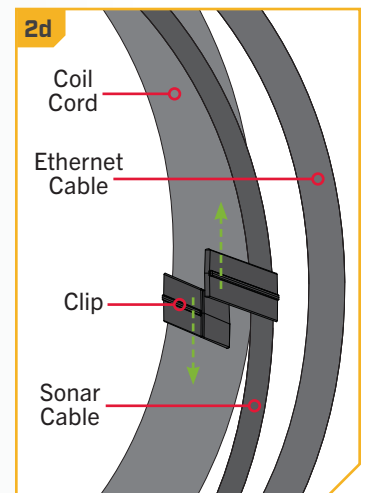
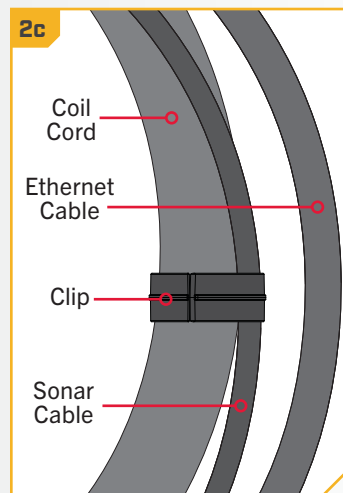

## CAUTION

Do not over-tighten the Clips as it may damage the wires.

## › Installing the Prop

1

### **CAUTION**

Disconnect the motor from the battery before beginning any prop work or maintenance.

- a. While holding the Shipping Spacer with a pliers or vise grip, remove the Prop Nut, Red Shipping Washer, Prop Washer and Spacer, being careful not to lose the Drive Pin. Reuse the Prop Nut, Prop Washer and Drive Pin to attach the Propeller.

**NOTICE:** The Shipping Spacer and Red Shipping Washer are for shipping purposes only and must be discarded. The Red Shipping Washer will rust if used to attach the Propeller.

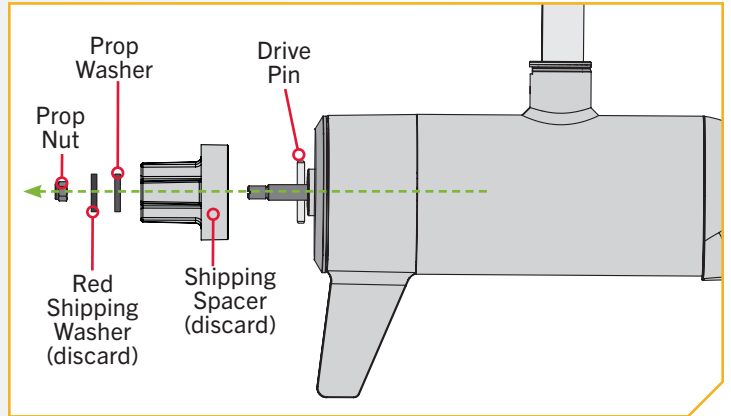

2

### ITEM(S) NEEDED



- b. Take the Drive Pin (Item #22) and slide it through the Hole in the Armature Shaft. Position the Drive Pin horizontally by grasping the Armature Shaft and rotating it with the Drive Pin in place.
- c. Align the Propeller (Item #19) so it is also horizontal and parallel with the Drive Pin. Slide the Propeller onto the Armature Shaft and Drive Pin until it is seated against the lower unit.
- d. Install the Prop Washer (Item #20) and the Prop Nut (Item #21) onto the end of the Armature Shaft.

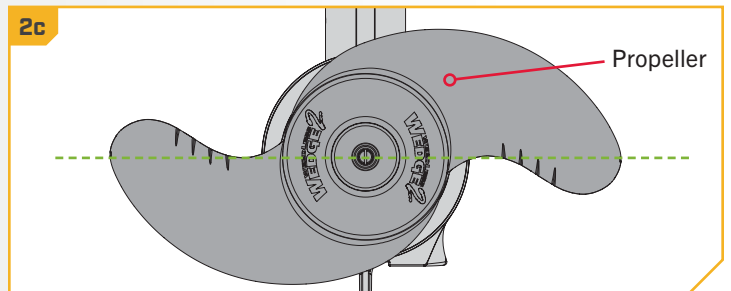
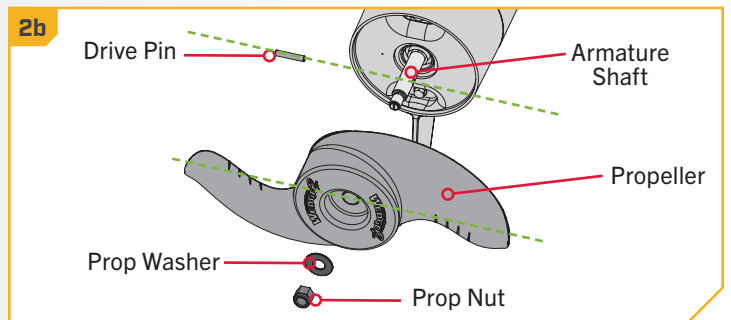



## INSTALLING THE PROP

3

- e. Holding the end of the Armature Shaft with a Flat Blade Screwdriver, tighten the Prop Nut with a 9/16" Box End or Open End Wrench.
- f. Tighten the Prop Nut 1/4 turn past snug to 25-35 in-lbs.



### CAUTION

Do not over-tighten as this can damage the prop.

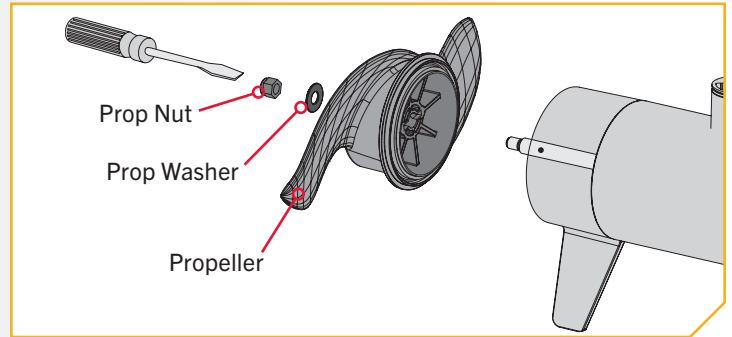

# BATTERY & WIRING INSTALLATION

## BOAT RIGGING & PRODUCT INSTALLATION

For safety and compliance reasons, we recommend that you follow American Boat and Yacht Council (ABYC) standards when rigging your boat. Altering boat wiring should be completed by a qualified marine technician. The following specifications are for general guidelines only:

### CAUTION

These guidelines apply to general rigging to support your Minn Kota motor. Powering multiple motors or additional electrical devices from the same power circuit may impact the recommended conductor gauge and circuit breaker size. If you are using wire longer than that provided with your unit, follow the conductor gauge and circuit breaker sizing table below. If your wire extension length is more than 25 feet, we recommend that you contact a qualified marine technician.

### CAUTION

**An over-current protection device (circuit breaker or fuse) must be used.** Coast Guard requirements dictate that each ungrounded current-carrying conductor must be protected by a manually reset, trip-free circuit breaker or fuse. The type (voltage and current rating) of the fuse or circuit breaker must be sized accordingly to the trolling motor used. The table below gives recommended guidelines for circuit breaker sizing.

## CONDUCTOR GAUGE AND CIRCUIT BREAKER SIZING TABLE

This conductor and circuit breaker sizing table is only valid for the following assumptions:

1. No more than 2 conductors are bundled together inside of a sheath or conduit outside of engine spaces.
2. Each conductor has 105° C temp rated insulation.
3. No more than 3% voltage drop allowed at full motor power based on published product power requirements.

Motor Thrust / Model	Max Amp Draw	Circuit Breaker		Wire Extension Length				
		Amp	Minimum	5 feet	10 feet	15 feet	20 feet	25 feet
80 lb.	56	60 Amp	24 VDC	8 AWG	6 AWG	6 AWG	4 AWG	2 AWG
112 lb.	52	60 Amp	36 VDC	8 AWG	8 AWG	8 AWG	6 AWG	4 AWG

**NOTICE:** Wire Extension Length refers to the distance from the batteries to the trolling motor leads. Consult website for available thrust options. Maximum Amp Draw values only occur intermittently during select conditions and should not be used as continuous amp load ratings.

#### Reference

United States Code of Federal Regulations: 33 CFR 183 – Boats and Associated Equipment ABYC E-11: AC and DC Electrical Systems on Boats

## SELECTING THE CORRECT BATTERIES

### SELECTING THE CORRECT BATTERIES

The motor will operate with any lead-acid, deep-cycle marine 12-volt battery/batteries. For best results, use a deep-cycle marine battery with at least a 105 amp-hour rating. Maintain battery at full charge. Proper care will ensure having battery power when you need it, and will significantly improve the battery life. Failure to recharge lead-acid batteries (within 12-24 hours) is the leading cause of premature battery failure. Use a multi-stage charger to avoid overcharging. We offer a wide selection of chargers to fit your charging needs. If you are using a crank battery to start a gasoline outboard, we recommend that you use a separate deep cycle marine battery/batteries for your Minn Kota trolling motor. For more information on battery selection and rigging, please visit [minnkota.johnsonoutdoors.com](http://minnkota.johnsonoutdoors.com). Minn Kota trolling motors can run on Lithium-Ion batteries. However, they are specifically designed to run on traditional lead-acid batteries (flooded, AGM or GEL). Lithium-Ion batteries maintain higher voltages for longer periods of time than lead acid. Therefore, running a Minn Kota trolling motor at speeds higher than 85% for a prolonged period could cause permanent damage to the motor.

#### **WARNING**

Never connect the (+) and the (-) terminals of the same battery together. Take care that no metal object can fall onto the battery and short the terminals. This would immediately lead to a short and extreme fire danger.

#### **CAUTION**

Refer to “Conductor Gauge and Circuit Breaker Sizing Table” in the previous section to find the appropriate circuit breaker or fuse for your motor. For motors requiring a 60-amp breaker, the Minn Kota MKR-19 60-amp circuit breaker is recommended.

#### **CAUTION**

Please read the following information before connecting your motor to your batteries in order to avoid damaging your motor and/or voiding your warranty.

### ADDITIONAL CONSIDERATIONS

#### › Using Alternator Chargers

Your Minn Kota trolling motor may be designed with an internal bonding wire to reduce sonar interference. Most alternator charging systems do not account for this bonding wire, and connect the negative posts of the trolling motor batteries to the negative posts of the crank/starting battery. These external connections can damage connected electronics and the electrical system of your trolling motor, voiding your warranty. Review your charger’s manual carefully or consult the manufacturer prior to use to ensure your charger is compatible.

Minn Kota recommends using Minn Kota brand chargers to recharge the batteries connected to your Minn Kota trolling motor, as they have been engineered to work with motors that include a bonding wire.

#### › Additional Accessories Connected to Trolling Motor Batteries

Significant damage to your Minn Kota motor, your boat electronics, and your boat can occur if incorrect connections are made between your trolling motor batteries and other battery systems. Minn Kota recommends using an exclusive battery system for your trolling motor. Where possible, accessories should be connected to a separate battery system. Radios and sonar units should not be connected to any trolling motor battery systems as interference from the trolling motor is unavoidable. If connecting any additional accessories to any trolling motor battery system, or making connections between the trolling motor batteries and other battery systems on the boat, be sure to carefully observe the information below.

## CONNECTING THE BATTERIES IN SERIES

The negative (-) connection must be connected to the negative terminal of the same battery that the trolling motor negative lead connects to. In the diagrams below this battery is labeled “Low Side” Battery. Connecting to any other trolling motor battery will input positive voltage into the “ground” of that accessory, which can cause excess corrosion. Any damage caused by incorrect connections between battery systems will not be covered under warranty.

### › Automatic Jump Start Systems and Selector Switches

Automatic jump start systems and selector switches tie the negatives of the connected batteries together. Connecting these systems to the “High Side” Battery or “Middle” Battery in the diagrams below and will cause significant damage to your trolling motor and electronics. The only trolling motor battery that is safe to connect to one of these systems is the “Low Side” Battery.

**NOTICE:** The internal bonding wire is equipped with a 3-amp fuse. Improper connections described above carrying in excess of 3 amps will blow this fuse and no further damage will be exhibited. If this occurs, RF interference from the trolling motor affecting sonar units and other electronics will be more significant. If the fuse is blown the wiring error should be found and addressed prior to replacing the fuse. The replacement fuse should be 3 amps or less. An intact fuse does not imply correct rigging; significant damage can be done by incorrect wiring without approaching 3 amps of current.

## CONNECTING THE BATTERIES IN SERIES (IF REQUIRED FOR YOUR MOTOR)

### › 24-Volt Systems

Two 12-volt batteries are required. The batteries must be wired in series, only as directed in the wiring diagram, to provide 24 volts.

1. Make sure that the motor is switched off (speed selector on “0”).
2. Connect a connector cable to the positive (+) terminal of battery 1 and to the negative (-) terminal of battery 2.
3. Connect positive (+) red motor lead to positive (+) terminal on battery 2.
4. Connect negative (-) black motor lead to negative (-) terminal of battery 1.

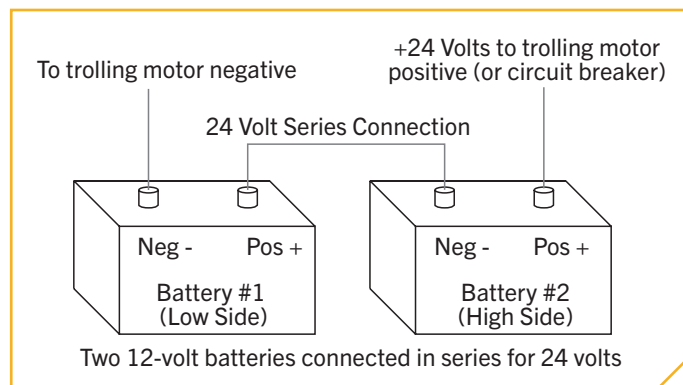

## WARNING

For safety reasons do not switch the motor on until the propeller is in the water. If installing a leadwire plug, observe proper polarity and follow instructions in your boat owner’s manual.

## WARNING

- For safety reasons, disconnect the motor from the battery or batteries when the motor is not in use or while the battery/batteries are being charged.
- Improper wiring of 24/36 volt systems could cause battery explosion.
- Keep leadwire wing nut connections tight and solid to battery terminals.
- Locate battery in a ventilated compartment.

# CONNECTING THE BATTERIES IN SERIES

## 36-Volt Systems

Three 12-volt batteries are required. The batteries must be wired in series, only as directed in the wiring diagram, to provide 36 volts.

1. Make sure that the motor is switched off (speed selector on "0").
2. Connect a connector cable to the positive (+) terminal of battery 1 and to the negative (-) terminal of battery 2 and another connector cable from the positive (+) terminal of battery 2 to the negative (-) terminal of battery 3.
3. Connect positive (+) red motor lead to positive (+) terminal on battery 3.
4. Connect negative (-) black motor lead to negative (-) terminal of battery 1.

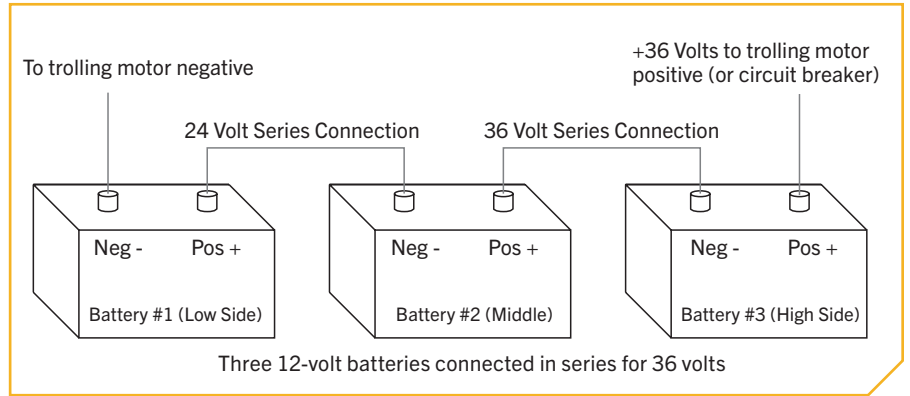

### WARNING

For safety reasons, do not switch the motor on until the propeller is in the water. If installing a leadwire plug, observe proper polarity and follow instructions in your boat owner's manual.

### WARNING

- For safety reasons, disconnect the motor from the battery or batteries when the motor is not in use or while the battery/batteries are being charged.
- Improper wiring of 24/36 volt systems could cause battery explosion.
- Keep leadwire wing nut connections tight and solid to battery terminals.
- Locate battery in a ventilated compartment.

# MOTOR WIRING DIAGRAM

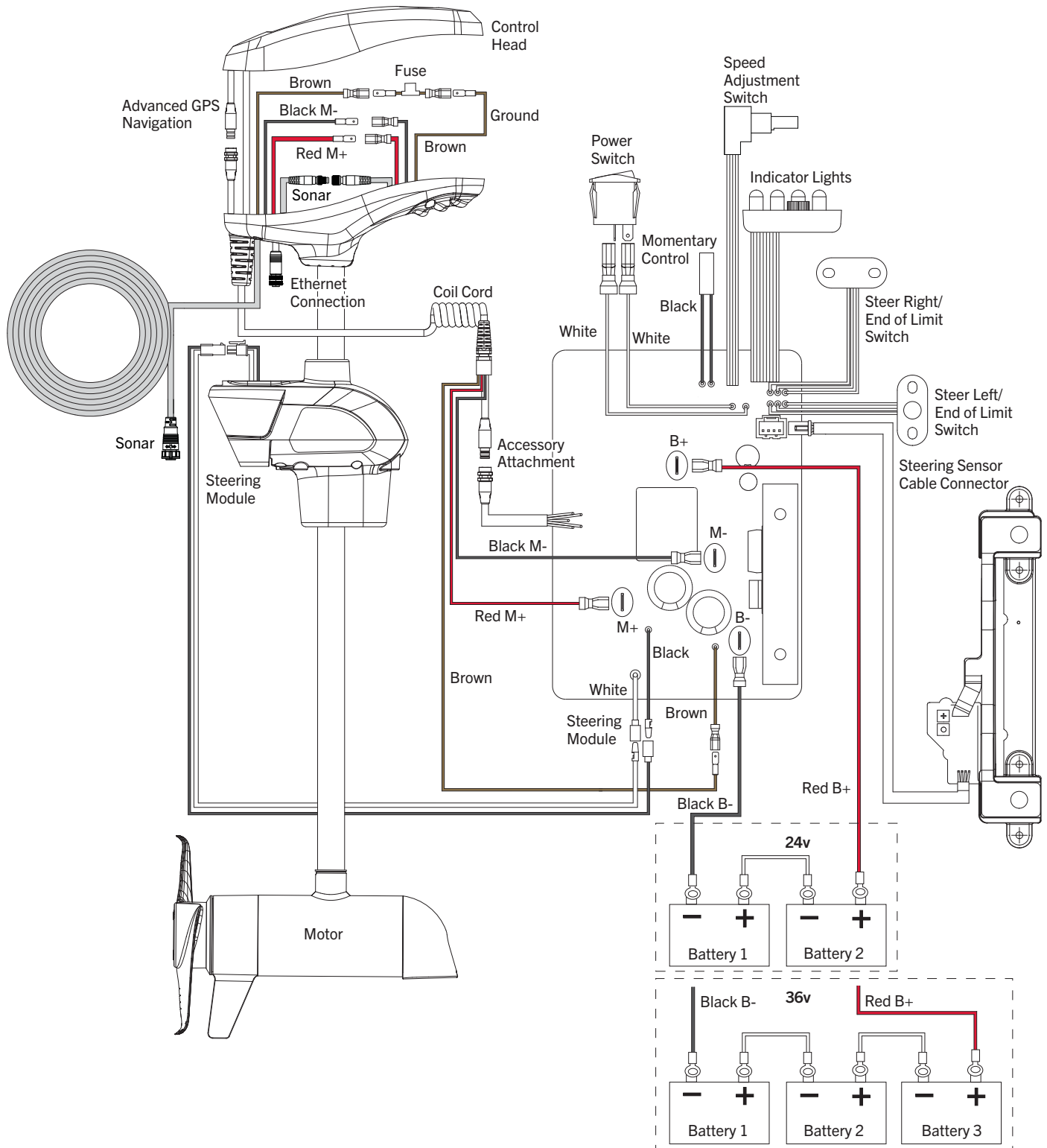

**NOTICE:** This is a multi-voltage diagram. Double-check your motor's voltage for proper connections. Over-Current Protection Devices are not shown in this illustration.

# USING & ADJUSTING THE MOTOR

## MOUNT FEATURES

Become familiar with the features of the motor to maximize the capabilities this product offers.

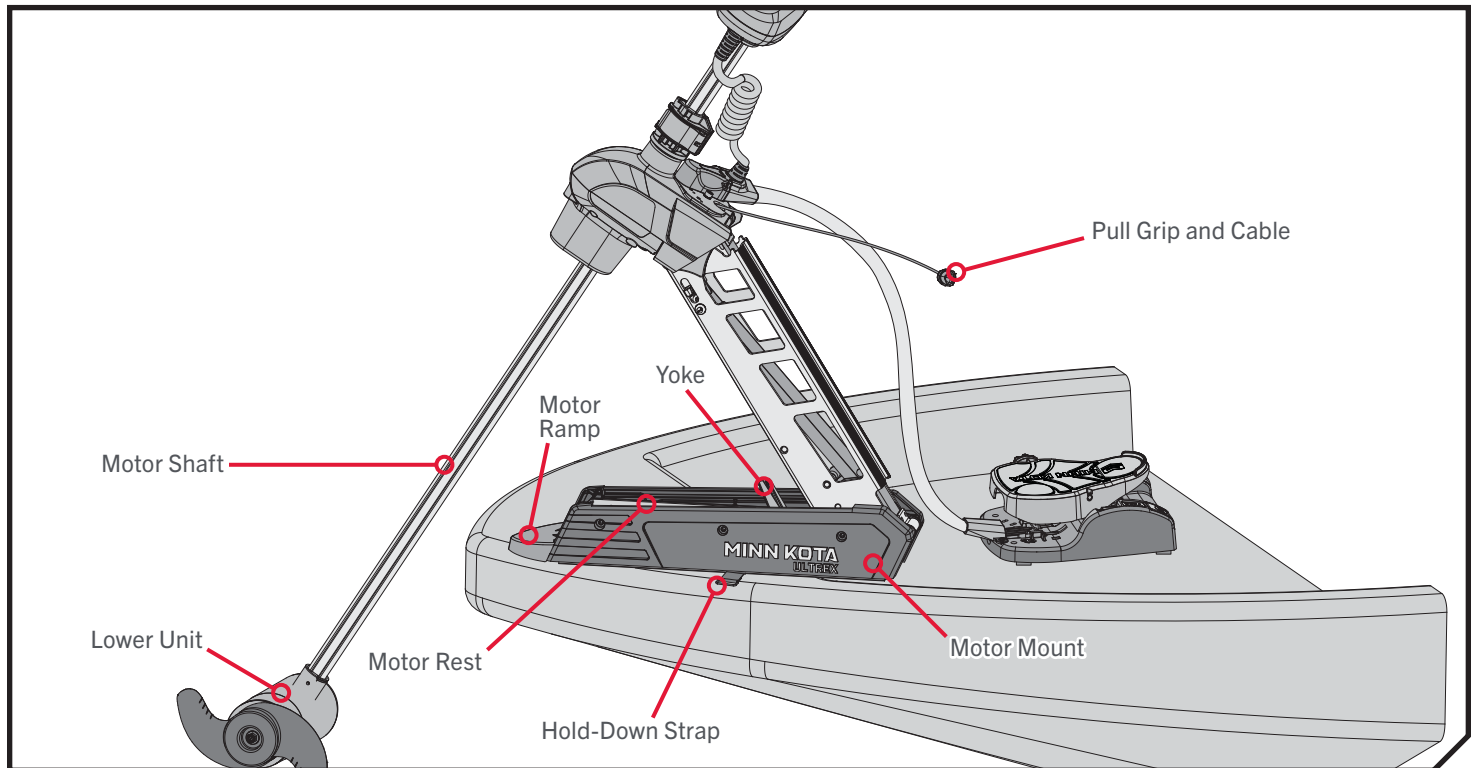

### › Motor Mount

The Motor Mount is designed to securely hold the motor in place on the deck of the boat. It functions to stow and lock the motor flat on the deck when not in use by providing secure stowage for transport. The Motor Mount also positions the motor when it is in the deployed position.

### › Pull Grip and Cable

The Pull Grip and Cable releases the lock bar on the Motor Mount, which automatically engages when the unit is stowed or deployed into position. The Pull Grip and Cable should be used to assist when both stowing and deploying the unit. Inspect the Pull Grip and Cable during each use and replace when it shows signs of wear.



## WARNING

When stowing or deploying the motor, keep fingers clear of all hinges, pivot points and moving parts. Always use the Pull Grip and Cable to stow and deploy the motor to prevent injury.

### › Motor Rest and Yoke

The Motor Rest positions the lower unit as it comes into contact with the nose of the mount and guides it onto the Motor Mount. The Yoke sits in the middle of the Motor Rest and captures the motor shaft. The Yoke keeps the lower unit centered on the Motor Rest when in the stowed position.

### › Hold-Down Strap

The Hold-Down Strap must be used to place pressure on the motor shaft to hold the lower unit tightly against the Motor Rest when stowed. The Hold-Down Strap runs under the Mount and is properly secured when the motor shaft is secured on the Motor Rest and the strap is secured to itself. The Hold-Down Strap should be secured every time the motor is stowed to prevent damage from high wind, rough water or vibrations, including while the boat is trailered.



# STOWING AND DEPLOYING THE MOTOR

## STOWING AND DEPLOYING THE MOTOR

### › To Deploy the Motor

Make sure that the Hold-Down Strap is not secured and then simply pull back and lift the motor off of the mount with the Pull Grip and Cable. Lower the motor into the water using the Pull Grip and Cable. The motor will lock into the deployed position. Once the motor is deployed, make sure it is seated and locked into position.



## WARNING

When stowing or deploying the motor, keep fingers clear of all hinges, pivot points and moving parts.

### › To Stow the Motor

Pull back and lift the motor out of the water with the Pull Grip and Cable. Guided by the Pull Grip and Cable, the lower unit will drop down onto the Motor Rest. The motor will lock into the stowed position. Once the motor is stowed, make sure it is seated and locked into position. Wrap the Hold-Down Strap over top of the motor shaft to secure the motor. When stowing the motor, it automatically disables the operational function of the foot pedal or paired remote. "Motor stowed" will be displayed on the screen of any applicable remote.

## MOTOR ADJUSTMENTS ›

### › Adjusting the Lower Unit for a Secure Stow

When the Motor is stowed, the Lower Unit should lie on the Motor Rest Rails just inside the sideplates of the Motor Mount. It is recommended to secure the motor using the following instructions to avoid damage to the motor and shaft from vibrations during transport.

- 1 a. Before transporting the boat over water or land, stow the motor to determine where the Lower Unit rests on the Mount.

**NOTICE:** The correct positioning of the Lower Unit will place it directly on the Motor Rest located on the Motor Mount.

- b. If the Lower Unit does not sit on the Motor Rest, deploy the motor so the Depth Collar can be unlatched and the motor can be adjusted to allow it to lie on the Motor Rest.

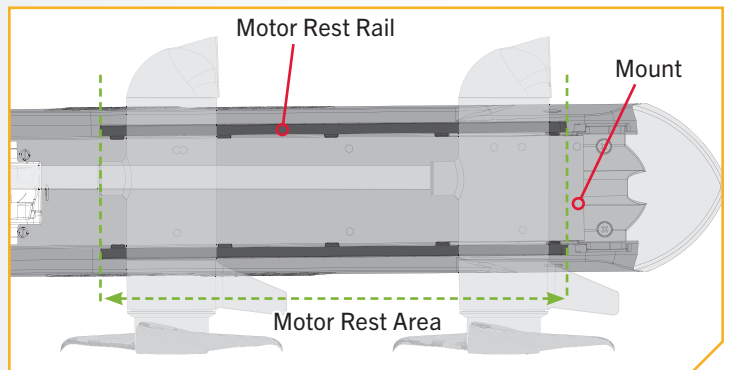
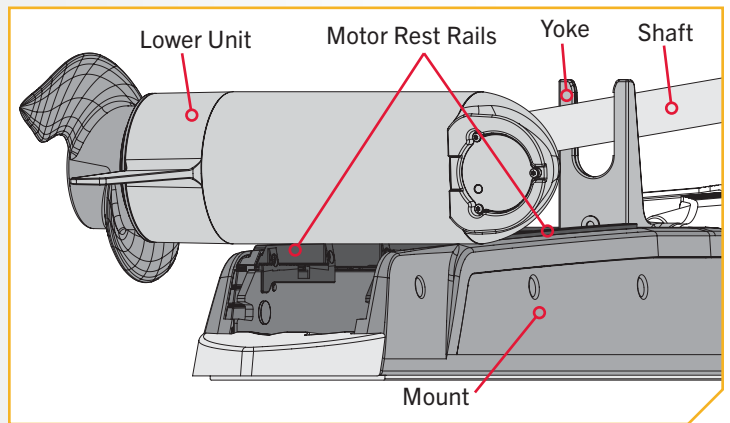

## CAUTION

The Lower Unit should be placed on the Motor Rest Rails within the Motor Rest Area every time the motor is transported. If the Lower Unit is improperly placed, either above or below the Motor Rest Area, the Shaft will be incorrectly captured in the Yoke and damage to the Lower Unit or Shaft will occur. Failure to follow the recommended placement for the Lower Unit will cause damage to the product and void your product warranty.

# ADJUSTING THE DEPTH OF THE MOTOR

**2**

- c. With the motor in the deployed position, firmly grasp the motor Shaft above the Steering Module.
- d. Locate the Depth Collar on the Shaft. While holding the Shaft in place, unlatch the Depth Collar so that the Shaft can slide freely.
- e. Raise or lower the motor to the desired depth.
- f. Relatch the Depth Collar to secure the motor in place.
- g. Stow the motor again and confirm that the Lower Unit is resting on the Motor Rest Rails within the Motor Rest Area. If it is not resting in the recommended location, re-deploy the motor and re-adjust until it sits where recommended when stowed.

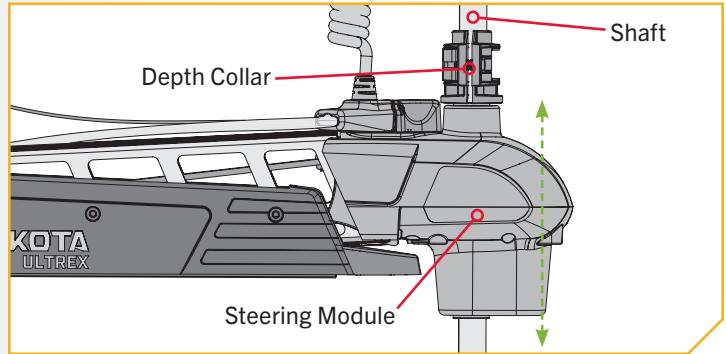

**NOTICE:** Once the Lower Unit is sitting in the proper position on the Motor Rest, always secure it in place with the Hold-Down Strap.

## Adjusting the Depth of the Motor

Once the boat is on the water, it may be necessary to adjust the lower unit up or down to achieve an optimum depth for motor performance. When setting the depth of the motor, be sure that the top of the motor is submerged at least 12" below the surface of the water to avoid churning or agitation of surface water.

**1**

- a. With the motor in the deployed position, firmly grasp the motor Shaft above the Steering Module.
- b. Locate the Depth Collar on the Shaft. While holding the Shaft in place, unlatch the Depth Collar so that the Shaft can slide freely.

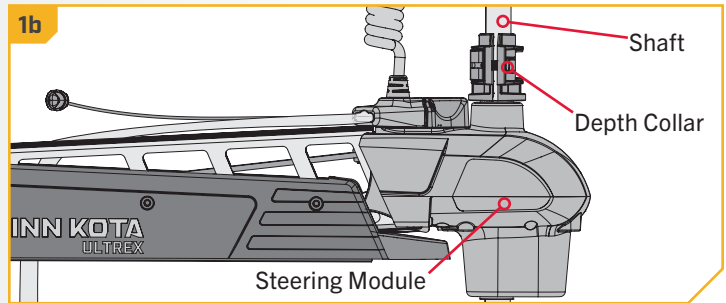

**WARNING**

The Control Head will create a pinch point if the Depth Collar is unlatched and the Control Head slides to the top of the Depth Collar. Grasp the Shaft and prevent it from sliding all the way down to prevent the pinch point.

- c. Raise or lower the motor to the desired depth.
- d. Relatch the Depth Collar to secure the motor in place.

**NOTICE:** Please be sure that the top of the motor is submerged at least 12" below the surface of the water to avoid churning or agitating the water surface.

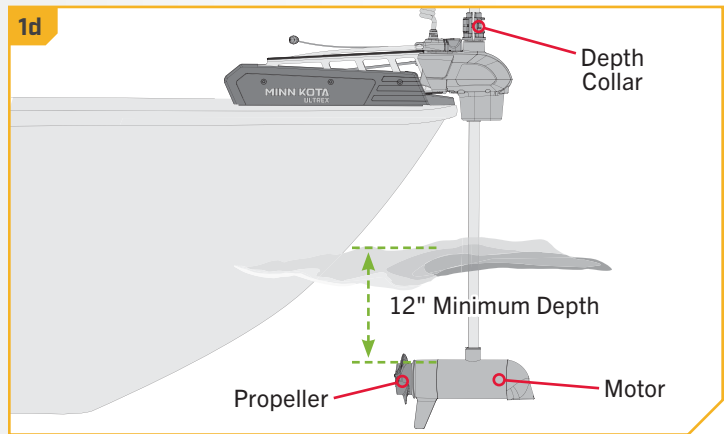

## Adjusting the Pull Grip and Cable

The length of the Cable on the Pull Grip and Cable can be adjusted based on personal preference. Before beginning the adjustment, the Gas Spring must be disengaged and the Steering Module must be removed. Please refer to the Removal of the Steering Module section and follow the procedure to Disconnect the Gas and Remove Motor from Mount. It is important to remove the Gas Spring and the Steering Module in order to access the Cable and associated hardware to make any adjustments.

1

### WARNING

Please refer to the Removal of the Steering Module section of this manual and follow the procedure to Disconnect the Gas Spring and Remove Motor from Mount. It is important to remove the Steering Module and Remove the Gas Spring in order to access the Cable and associated hardware to make the adjustment. Failure to complete these necessary steps will prevent the adjustment from being possible and will result in risk of injury.

- a. With the Gas Spring disconnected and the Steering Module removed, ensure that the mount is in the deployed position.

**NOTICE:** Observe how the Cable is routed through the Cable Guide, around the Pin, and into the Latch/Strap Cable Pull Bracket.

- b. Locate the end of the Cable and the Pull Cable Clamp inside the Aluminum Arm of the Mount.

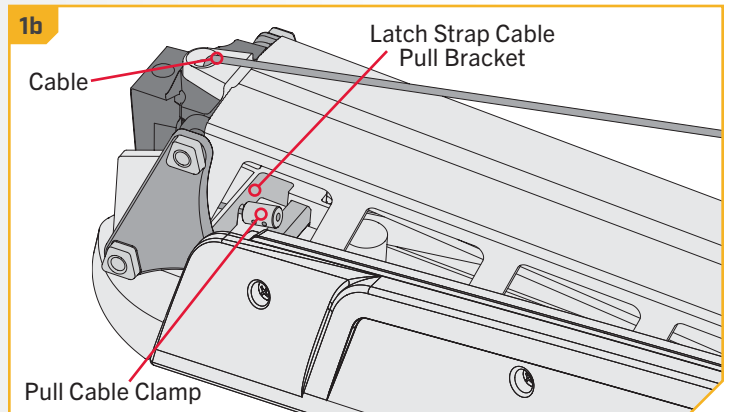
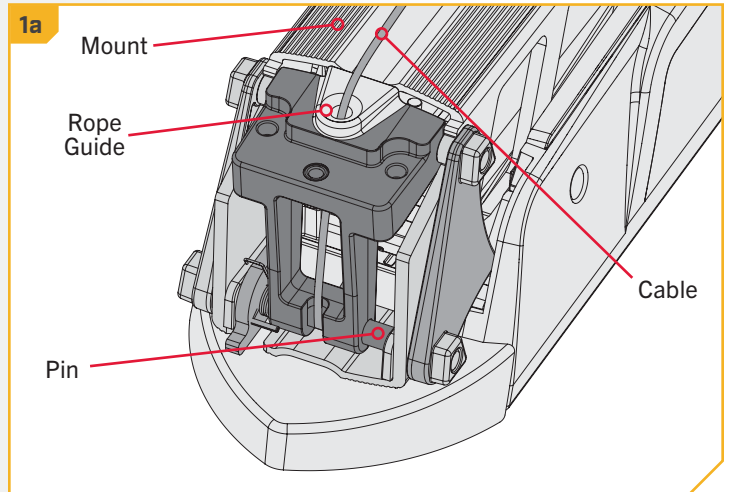

## ADJUSTING THE PULL GRIP AND CABLE

2

- c. Grasp the Pull Cable Clamp and Cable and pull it out of the Aluminum Arm.
- d. The Pull Cable Clamp contains two Set Screws. Loosen- but do not remove- these two screws with a 5/64 Allen Wrench until the Cable can slide in the Pull Cable Clamp.
- e. Adjust the Cable to the desired length.
- f. Retighten the two Set Screws using the 5/64 Allen Wrench. Tighten the Set Screws to 16-19 in-lbs. Be sure that the Set Screws are properly seated on the Cable in the Pull Cable Clamp. The Set Screws must provide adequate tension on the Cable to keep it retained in the Pull Cable Clamp during normal operation. When the two Set Screws are properly tightened, they must be recessed slightly below the surface of the Pull Cable Clamp.

**NOTICE:** Be sure the two Set Screws are tightened adequately. When properly tightened, the two Set Screws must at least be recessed below the Pull Cable Clamp to maintain tension on the Cable in the Pull Cable Clamp during normal operation.

- g. Using a Hack Saw, trim the Cable so there is no more than 1/16" excess beyond the Pull Cable Clamp.

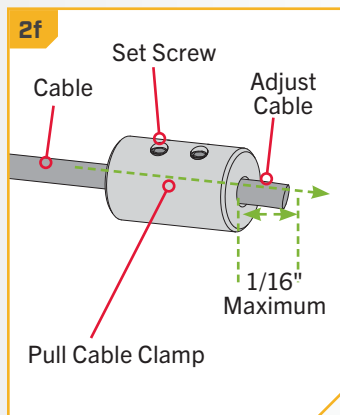
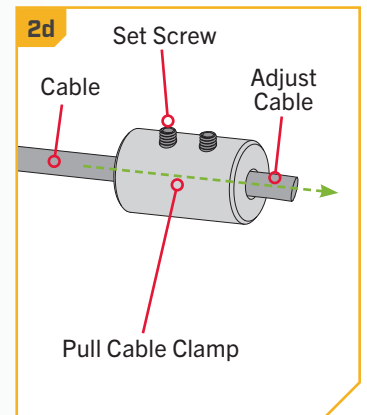
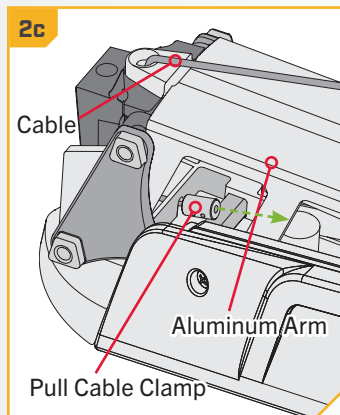

3

- h. Once the Cable has been cut to length, take the Pull Grip and pull the Cable back into place until it is seated against the Latch Strap Cable Pull Bracket.
- i. After the Cable is in place, refer to the "Removal of the Steering Module" section of these instructions and follow the procedure to "Reassemble the Steering Module."

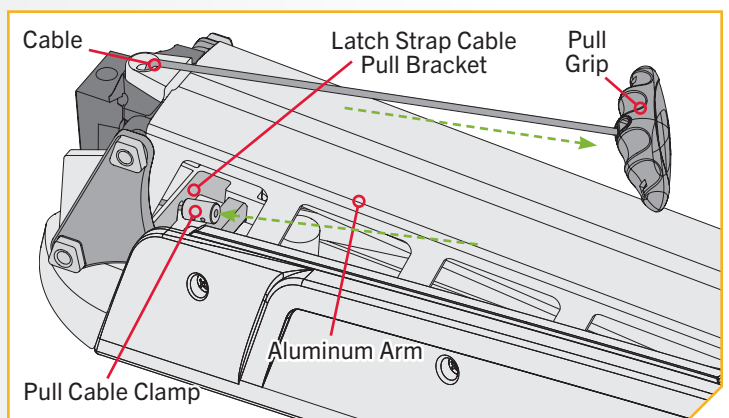

# INSTALLING AN EXTERNAL TRANSDUCER

## INSTALLING AN EXTERNAL TRANSDUCER

An external transducer is not included with your trolling motor. An external transducer can be installed onto motors that have Advanced GPS Navigation. Installing an external transducer is not recommended for motors with Built-in MEGA Down Imaging.

- 1
  - a. Mount the External Transducer according to directions provided with the transducer.
  - b. Leave enough slack in the Transducer Cable between the Lower Unit and Control Head to allow the motor to properly stow and deploy.
  - c. Use two tie wrap cables to secure the Transducer Cable to the Shaft just above the Lower Unit and just below the Control Head.
  - d. Run the Transducer Cable through the Coil Cord to the power supply.

### CAUTION

Failure to follow the recommended wire routing for Sonar and External Transducer Cables may cause damage to the product and void your product warranty. Take care to test the length and placement of all cables to ensure that there is enough slack where needed and that cables are free of entanglement by moving parts. Routing the cables in any way other than as directed may cause damage to the cables via pinching or severing.

**NOTICE:** For additional details on cable routing, see the "Securing Accessory Cables" section of this manual.

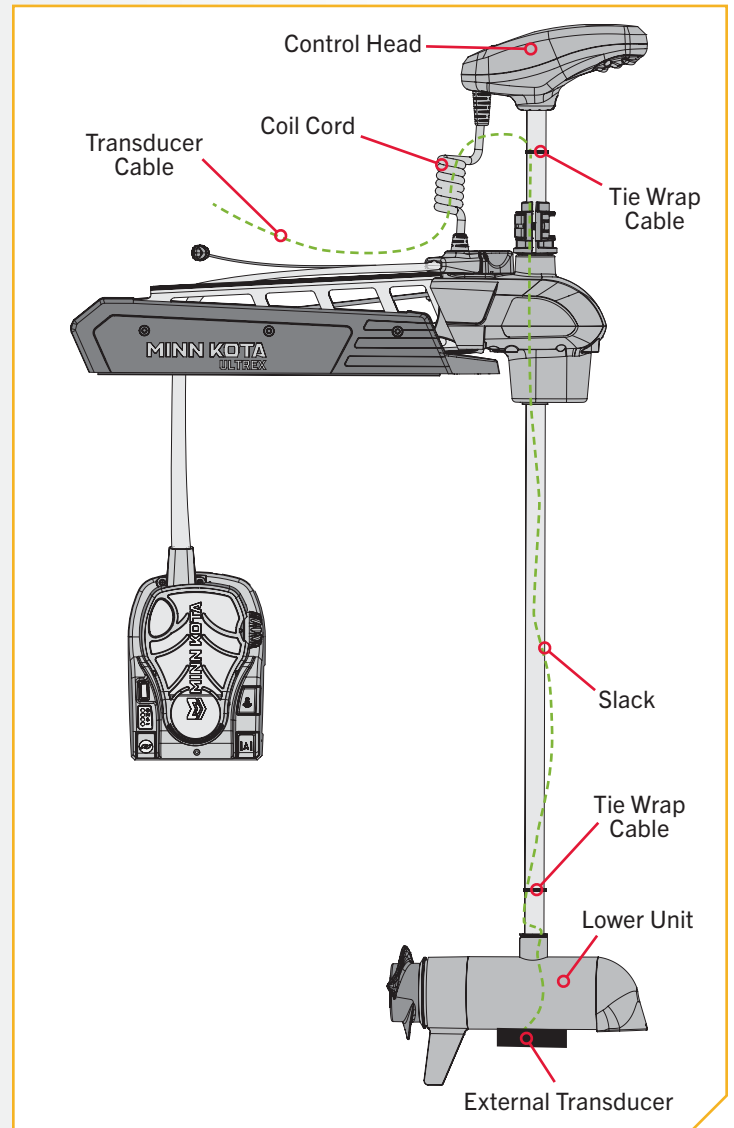

# USING THE FOOT PEDAL

## CONTROLLING SPEED & STEERING WITH THE FOOT PEDAL

The foot pedal is used to operate the motor. The controls on the foot pedal are easy to operate by either foot or hand. The motor can also be controlled by the Minn Kota micro remote, as well as any compatible Minn Kota remote. Please refer to the associated remote manual for respective instructions. To learn more about accessories that are compatible with the Ultrex, please visit [minnkota.johnsonoutdoors.com](http://minnkota.johnsonoutdoors.com).

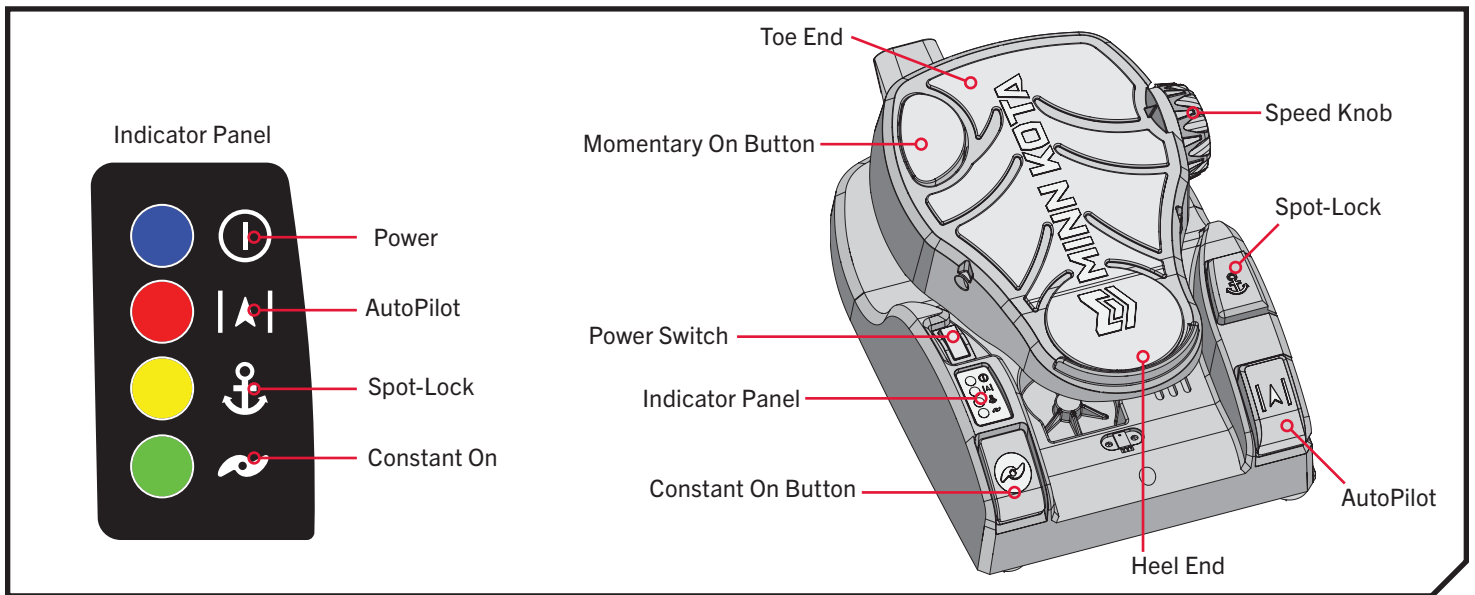

### › Power

The Power Switch is located on the left-hand side of the foot pedal and is used to turn the power on and off. The blue light next to the Power icon (⏻) on the Indicator Panel is illuminated when the power is on. Do not try to steer this motor with the foot pedal when it has lost power.

**NOTICE:** Remember to turn the power off when the motor is not in use to prevent the motor from draining the battery.

### › Motor Speed

The Speed Knob is located on the top-right side of the Toe End of the foot pedal. Turn the Speed Knob clockwise to increase speed and counter-clockwise to decrease speed. Speed can also be adjusted using a Minn Kota-compatible remote.

### › Momentary Motor Operation

In Momentary Motor Operation, the propeller will only run while downward force is applied to the Momentary On Button. The Momentary On Button is located on the top-left Toe End of the foot pedal. Applying downward pressure to the Momentary On Button will turn the propeller on. The motor will then run at the speed set by the Speed Knob. Removing downward force to the Momentary On Button will turn the propeller off. No indicator light is associated with the Momentary On Button.

### › Constant Motor Operation

To switch to Constant Motor Operation, press the Constant On Button. The Constant On Button is located on the bottom-left Heel End of the foot pedal and is labeled on the foot pedal with a propeller symbol. In Constant mode, the propeller will continually run, regardless of whether or not force is being applied to the Momentary On Button. While in Constant Motor Operation, the propeller will run continuously at the speed set by the Speed Knob, or by a Minn Kota wireless remote. The green light next to the Constant On icon (⚓) on the Indicator Panel will be lit when the motor is in Constant Motor Operation.



# CONTROLLING SPEED & STEERING WITH THE FOOT PEDAL

////////////////////////////////////

If the propeller is running and encounters an obstruction while in Momentary or Constant Mode, the increased electrical current generated by the obstruction will signal the motor to decrease power to the propeller to prevent damage. If the current overload is detected for more than 20 seconds, the prop will be disabled to prevent damage to the motor. In this event, the operator can turn the prop back on after ensuring that the obstruction has been cleared.

## › Turn Left or Right

Push the Toe End of the foot pedal down to turn right and push the Heel End of the foot pedal down to turn left. The position and direction of the Steering Head directly corresponds to the position of the motor. When turning left or right, the steering motion will end when the cables controlling the direction of the Steering Head and Motor have come to the end of their range of motion. You must use your foot on the pedal to control the steering direction during manual operation. The foot pedal is pressure sensitive. Applying gradual pressure to either the Toe or Heel End of the foot pedal will cause the direction to turn gradually. A higher amount of pressure will turn the unit more quickly in the engaged direction. The direction of the motor can also be controlled with a remote. Since the direction of the motor is controlled by pressure applied to the foot pedal and the reaction of the cables to that pressure, the motor will not turn straight without manually applying pressure to the foot pedal (or by using a remote) to align the cables to engage the motor to steer it straight. Due to the Steering Lock feature, the Steering Head and Motor will remain at the last steered position. Turning left or right can also be controlled by the Minn Kota micro remote. Refer to your remote manual to learn more.

 <b>CAUTION</b>
Make sure that the Power switch is turned off when the motor is not in use. If the motor control is left on and the propeller rotation is blocked, severe motor damage can result.
For safety reasons, disconnect the motor from the battery/ batteries when the motor is not in use or while the battery/ batteries are being charged.
Moving parts can cut or crush. Avoid pinch points when operating the Foot Pedal.

## › Steering in Reverse

The Control Head always indicates the direction of travel. To reverse the direction of travel, turn the Control Head in the complete opposite direction of its current location. Keep in mind that the steering motion will end when the cables controlling the direction of the Control Head have come to the end of their range of motion.

## › Spot-Lock

The Spot-Lock button is located on the right side of the foot pedal and is labeled with an anchor symbol. When the Spot-Lock button is pressed, the location of the motor is recorded to memory. The yellow light next to the Spot-Lock icon  on the Indicator Panel is illuminated when Spot-Lock is engaged. To engage Spot-Lock, press the Spot-Lock button. To disengage, press the Spot-Lock button again. When engaging Spot-Lock, a tone will be emitted. When disengaging Spot-Lock with the Spot-Lock button, no tone will be emitted. Steering the motor with the Foot Pedal or adjusting the speed using the Speed Knob will cancel Spot-Lock and a High-Low, High-Low, High-Low tone will be emitted. Spot-Lock can also be controlled with the remote. For more specific directions on how to use Spot-Lock, please refer to your remote manual.

 <b>WARNING</b>
You are responsible for the safe and prudent operation of your vessel. We have designed Ultrex to be an accurate and reliable tool that will enhance boat operation and improve your ability to catch fish. This product does not relieve you from the responsibility for safe operation of your boat. You must avoid hazards to navigation and always maintain a permanent watch so you can respond to situations as they develop. You must always be prepared to regain manual control of your boat. Learn to operate your Ultrex in an area free from hazards and obstacles.